



May 31, 2017

Advice No. 2138

Oregon Public Utility Commission  
201 High St. SE  
Salem, OR 97301-3612

Attention: Joan Grindeland, Tariff Coordinator

Dear Commissioners:

Pursuant to Qwest's Price Plan under ORS 759.255, Qwest Corporation d/b/a CenturyLink QC is filing notice of revisions to the sheets listed on Attachment A.

As described in the attached narrative ("Description of Methodology"), this filing is the sixth step in implementing the "Transitional Intrastate Access Service" reductions mandated by the Federal Communications Commission's November 18, 2011 Report and Order and Further Notice of Proposed Rulemaking in WC Docket Nos. 10-90, etc. (FCC 11-161). Also enclosed is CenturyLink's certification that the company is not seeking duplicative recovery in the state jurisdiction for any Eligible Recovery subject to the recovery mechanism established by the Transformation Order.

A paper copy of this filing including confidential calculations supporting the rate changes is being sent in a separate letter marked confidential.

The proposed effective date is July 1, 2017.

Yours very truly,

A handwritten signature in blue ink that reads "Mark Brinton".

Mark Brinton  
Manager Regulatory Operations  
Office: (303) 992-5832  
e-mail: [Mark.Brinton@CenturyLink.com](mailto:Mark.Brinton@CenturyLink.com)

Enclosures

**ACCESS SERVICE TARIFF**  
**P.U.C. OREGON NO. 32**

<b><u>SECTION</u></b>	<b><u>SHEET</u></b>	<b><u>REVISION</u></b>
2	53	1st
2	54	1st
2	55	1st
2	56	1st
2	56.1	Original
2	56.2	Original
2	56.3	Original
2	56.4	Original
2	57	1st
6	17	1st
6	187	3rd
6	187.1	Original
6	197	7th

# Qwest Corporation

P.U.C. OREGON No. 32  
ACCESS SERVICE

SECTION 2  
1st Revised Sheet 53  
Cancels Original Sheet 53

## 2. GENERAL REGULATIONS

### 2.4 PAYMENT ARRANGEMENTS AND CREDIT ALLOWANCES

#### 2.4.7 ORDERING, RATING AND BILLING OF ACCESS SERVICES WHERE MORE THAN ONE EXCHANGE TELEPHONE COMPANY IS INVOLVED (Cont'd)

- D. When jointly provisioned Switched Access Service is provided between the Company and another Exchange Telephone Company, the appropriate Switched Access recurring rates will be applied based on the type of Switched Transport provided, Tandem-Switched Transport (TST) or Direct-Trunked Transport (DTT). Tandem 3rd Party rates apply to terminating Traffic Types between the Company and another Exchange Telephone Company that is not a CenturyLink Operating Company (CLOC) ILEC. (C)

For Switched Access Service provisioned as TST, the appropriate Switched Access recurring rates for Terminating – Tandem 3rd Party or Originating will be applied as follows: 1) multiply the Tandem Transmission fixed rate by the minutes of use (MOU) by the billing percentage (BP), 2) multiply the Tandem Transmission per-mile rate by the number of miles, by the MOU by the BP, and 3) all other appropriate Switched Access recurring rate elements at 100 percent, if applicable. (C)

For Switched Access Service provisioned as DTT, the recurring rates will be applied as follows: 1) multiply the monthly Transport Channel fixed rate by the BP, 2) multiply the monthly Transport Channel per-mile rate by the number of miles, by the BP, and 3) all other appropriate Switched Access recurring rate elements at 100 percent, if applicable.

The Exchange Telephone Company that owns the access tandem will assess the appropriate access tandem Terminating – Tandem 3rd Party or Originating recurring rates at 100 percent. The Exchange Telephone Company that owns the end office will assess the appropriate end office recurring rates at 100 percent. (C)

- E. When jointly provisioned Switched Access Service is provided and the Company is the intermediate non-terminating carrier, only the recurring Tandem Transmission per-mile rate for Terminating – Tandem 3rd Party or Originating or DTT per-mile rate for Switched Access Service will apply. The Tandem Transmission Originating per-mile rate or Tandem Transmission Terminating – Tandem 3rd Party per-mile rate or DTT per-mile rate will be determined by multiplying the appropriate rate by the MOU by the number of miles, by the BP. The DTT per-mile rate will be determined by multiplying the appropriate DTT per-mile monthly rate by the number of miles by the BP. If the Company provides the access tandem, all appropriate access Tandem 3rd Party recurring rates will apply at 100 percent. (C)

- F. When jointly provisioned Access Service is provided between the Company and another Exchange Telephone Company, or when the Company is the intermediate non-terminating carrier, the appropriate nonrecurring charges shall apply. The BP is not applied to nonrecurring charges. (C)

# Qwest Corporation

P.U.C. OREGON No. 32  
ACCESS SERVICE

SECTION 2  
1st Revised Sheet 54  
Cancels Original Sheet 54

## 2. GENERAL REGULATIONS

### 2.4 PAYMENT ARRANGEMENTS AND CREDIT ALLOWANCES

#### 2.4.7 ORDERING, RATING AND BILLING OF ACCESS SERVICES WHERE MORE THAN ONE EXCHANGE TELEPHONE COMPANY IS INVOLVED (Cont'd)

G. Examples - Switched Access provisioned by Direct-Trunked Transport and Tandem-Switched Transport

(T)

### Feature Group D Access Service Ordered

#### Example 1

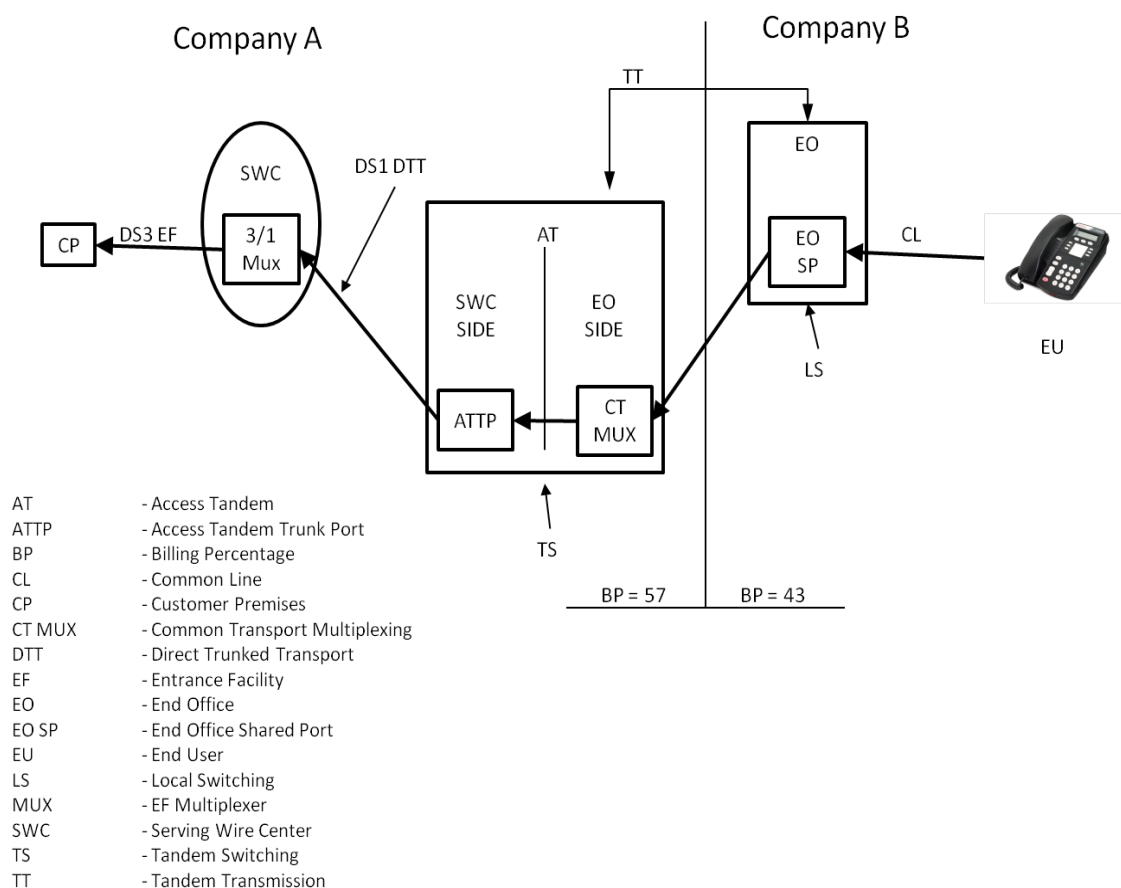

(C)

(C)

(T)

# Qwest Corporation

P.U.C. OREGON No. 32  
ACCESS SERVICE

SECTION 2  
1st Revised Sheet 55  
Cancels Original Sheet 55

## 2. GENERAL REGULATIONS

### 2.4 PAYMENT ARRANGEMENTS AND CREDIT ALLOWANCES

#### 2.4.7 ORDERING, RATING AND BILLING OF ACCESS SERVICES WHERE MORE THAN ONE EXCHANGE TELEPHONE COMPANY IS INVOLVED

- G. Examples - Switched Access provisioned by Direct Trunked Transport and Tandem-Switched Transport (Cont'd) (T)
1. Example 1 Layout (C)
    - a. Originating Feature Group D Switched Access is ordered to an end office via DTT and TST. Originating rates would apply. (C)  
(C)
    - b. The premises of ordering customer, the serving wire center (SWC) of that premises, and the access tandem are in operating territory of Company A. (C)
    - c. The customer orders a DS3 Entrance Facility from the customer's premises to the SWC with a 3/1 MUX in the SWC.
    - d. The customer orders a DS1 DTT to the AT.
    - e. The BP for TT is 57 for Company A. (C)
    - f. The end office is in the operating territory of Company B. (C)
    - g. The BP for transport is 43 for Company B. (C)

# Qwest Corporation

P.U.C. OREGON No. 32  
ACCESS SERVICE

SECTION 2  
1st Revised Sheet 56  
Cancels Original Sheet 56

## 2. GENERAL REGULATIONS

### 2.4 PAYMENT ARRANGEMENTS AND CREDIT ALLOWANCES

#### 2.4.7 ORDERING, RATING AND BILLING OF SWITCHED ACCESS SERVICES WHERE MORE THAN ONE EXCHANGE TELEPHONE COMPANY IS INVOLVED

G. Example - Switched Access provisioned by Direct Trunked Transport and Tandem-Switched Transport (Cont'd) (T)

#### 2. Rate elements assessed per Telephone Company

a. Company A (C)

Entrance Facility - 100% of DS3 monthly Entrance Facility rate and 3/1 MUX

DS1 DTT - 100% of DS1 monthly DTT rate

ATTP - 100% of ATTP monthly rate

Tandem Switching - MOU rate X MOU

Common Transport MUX - MOU rate X MOU

Tandem Transmission - Fixed rate X MOU X BP

Tandem Transmission - Per-mile rate X number of miles X MOU X BP

b. Company B (C)

Tandem Transport - Transport rate X MOU X BP

Local Switching - MOU rate X MOU

End Office Shared Port - MOU rate X MOU

Carrier Common Line - MOU rate X MOU

# Qwest Corporation d/b/a CenturyLink QC

P.U.C. OREGON No. 32  
ACCESS SERVICE

SECTION 2  
Original Sheet 56.1

## 2. GENERAL REGULATIONS

### 2.4 PAYMENT ARRANGEMENTS AND CREDIT ALLOWANCES

#### 2.4.7 ORDERING, RATING AND BILLING OF ACCESS SERVICES WHERE MORE THAN ONE EXCHANGE TELEPHONE COMPANY IS INVOLVED

G. Examples - Switched Access provisioned by Direct Trunked Transport and Tandem Switched Transport (Cont'd)

### Feature Group D Access Service Ordered

#### Example 2

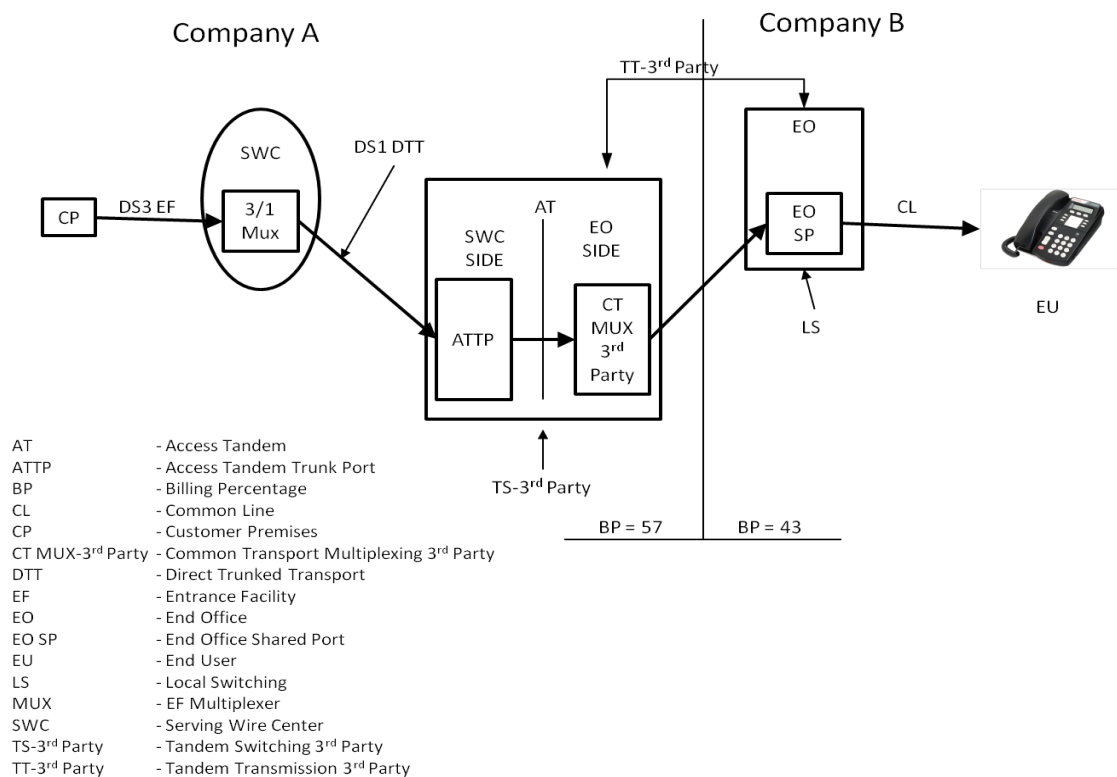

(N)

(N)

# Qwest Corporation d/b/a CenturyLink QC

P.U.C. OREGON No. 32  
ACCESS SERVICE

SECTION 2  
Original Sheet 56.2

## 2. GENERAL REGULATIONS

### 2.4 PAYMENT ARRANGEMENTS AND CREDIT ALLOWANCES

#### 2.4.7 ORDERING, RATING AND BILLING OF ACCESS SERVICES WHERE MORE THAN ONE EXCHANGE TELEPHONE COMPANY IS INVOLVED

##### G. Examples - Switched Access provisioned by Direct Trunked Transport and Tandem-Switched Transport (Cont'd)

##### 3. Example 2 Layout

- a. Terminating Feature Group D Switched Access is ordered to an end office via DTT & TST. Terminating – Tandem 3<sup>rd</sup> Party rates would appl.
- b. The premises of ordering customer, the serving wire center (SWC) of that premises, and the access tandem are in operating territory of Company A.
- c. The customer orders a DS3 Entrance Facility from the customer's premises to the SWC with a 3/1 Mux in the SWC.
- d. The customer orders a DS1 DTT to the AT.
- e. The BP for TT is 57 for Company A.
- f. Company B is not a CLOC ILEC.
- g. The end office is in the operating territory of Company B.
- h. The BP for transport is 43 for Company B.

(N)

(N)



# Qwest Corporation d/b/a CenturyLink QC

**P.U.C. OREGON No. 32**  
**ACCESS SERVICE**

**SECTION 2**  
**Original Sheet 56.3**

## 2. GENERAL REGULATIONS

### 2.4 PAYMENT ARRANGEMENTS AND CREDIT ALLOWANCES

#### 2.4.7 ORDERING, RATING AND BILLING OF ACCESS SERVICES WHERE MORE THAN ONE EXCHANGE TELEPHONE COMPANY IS INVOLVED

G. Examples - Switched Access provisioned by Direct Trunked Transport and Tandem Switched Transport (Cont'd)

### Feature Group D Access Service Ordered

Example 3

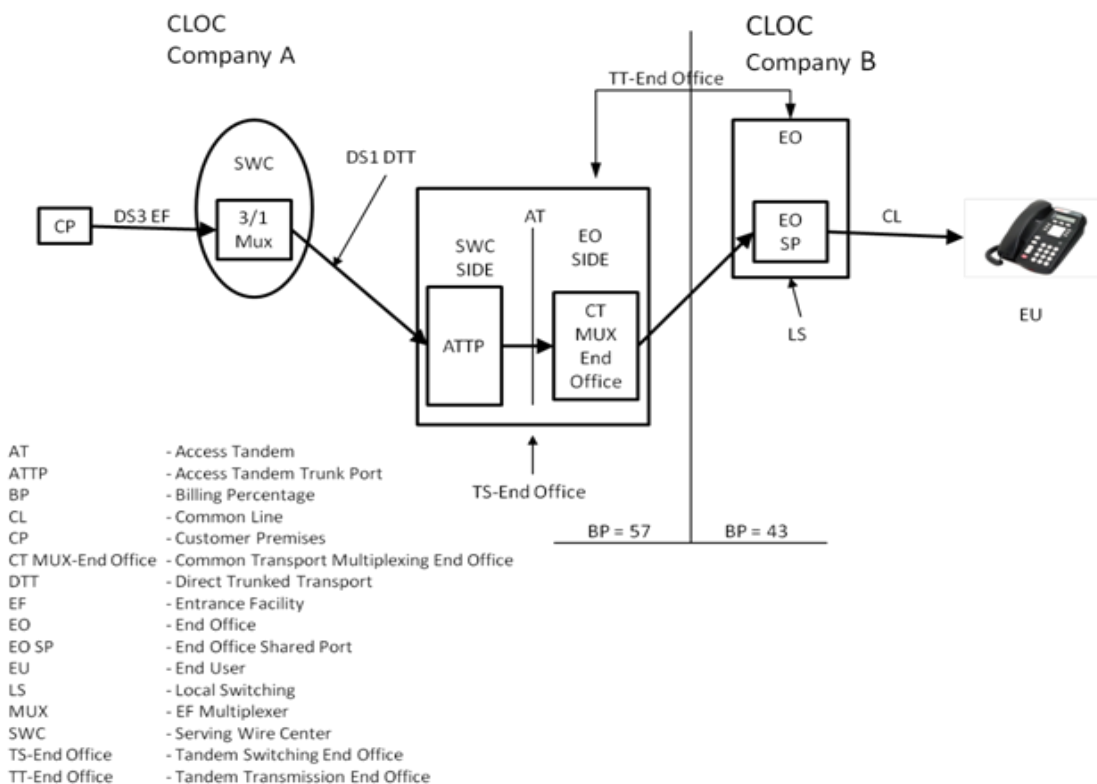

(N)

(N)

**Qwest Corporation d/b/a CenturyLink QC**

**P.U.C. OREGON No. 32  
ACCESS SERVICE**

**SECTION 2  
Original Sheet 56.4**

**2. GENERAL REGULATIONS**

**2.4 PAYMENT ARRANGEMENTS AND CREDIT ALLOWANCES**

**2.4.7 ORDERING, RATING AND BILLING OF ACCESS SERVICES WHERE MORE THAN ONE EXCHANGE TELEPHONE COMPANY IS INVOLVED**

**G. Examples - Switched Access provisioned by Direct Trunked Transport and Tandem-Switched Transport (Cont'd)**

**4. Example 3 Layout**

- a. Terminating Feature Group D Switched Access is ordered to an end office via DTT & TST. Terminating – Tandem End Office rates would apply
- b. The premises of ordering customer, the serving wire center (SWC) of that premises, and the access tandem are in operating territory of Company A.
- c. The customer orders a DS3 Entrance Facility from the customer's premises to the SWC with a 3/1 Mux in the SWC.
- d. The customer orders a DS1 DTT to the AT.
- e. The BP for TT is 57 for Company A.
- f. Company B is a CLOC ILEC.
- g. The end office is in the operating territory of Company B.
- h. The BP for transport is 43 for Company B.

(N)

(N)

# Qwest Corporation

P.U.C. OREGON No. 32  
ACCESS SERVICE

SECTION 2  
1st Revised Sheet 57  
Cancels Original Sheet 57

## 2. GENERAL REGULATIONS

### 2.4 PAYMENT ARRANGEMENTS AND CREDIT ALLOWANCES (Cont'd)

#### 2.4.8 ORDERING, RATING AND BILLING OF SWITCHED ACCESS SERVICE PROVIDED IN CONJUNCTION WITH A COMMERCIAL MOBILE RADIO SERVICE PROVIDER

When Switched Access Service is ordered by a customer in conjunction with a Commercial Mobile Radio Service provider, the Company will provide its portion of the Switched Access Service based on the regulations, rates and charges contained in this Tariff, subject to the following rules.

If the Company and the Commercial Mobile Radio Service provider have agreed to jointly provide the Switched Access Service, the Meet Point Billing provisions as set forth in 2.4.7, preceding, shall determine the ordering, rating and billing for access services.

If the Company and the Commercial Mobile Radio Service provider have not agreed to jointly provide the Switched Access Service under the provisions of Meet Point Billing, the Company shall provide the Switched Access Service to the carrier subject to the following rules.

- If the Company provides the Switched Transport and provides end office local switching functions, the customer will be assessed all applicable Switched Access rates (i.e., Switched Transport and Local Switching). Carrier Common Line rates will not be assessed.
- If the Company provides the Switched Transport and does not provide end office local switching functions the Company will assess all applicable Switched Access charges, including the Switched Transport Tandem 3rd Party charges.

(C)  
(C)

The mileage to be used to determine the Switched Transport rate is calculated as set forth in 6.7.11, following.

#### 2.4.9 RESERVED FOR FUTURE USE

# Qwest Corporation

P.U.C. OREGON No. 32  
ACCESS SERVICE

SECTION 6  
1st Revised Sheet 17  
Cancels Original Sheet 17

## 6. SWITCHED ACCESS SERVICE

### 6.1 GENERAL

#### 6.1.2 RATE CATEGORIES

##### A.1. (Cont'd)

##### b. Switched Transport DTT Rate Category

DTT provides the transmission path on circuits dedicated to the use of a single customer between:

- the customer's SWC and an end office, or
- the customer's SWC and an access tandem, or
- the customer's SWC and a Company Hub where multiplexing functions are performed, or
- a Company Hub and an end office, or
- a Company Hub and an access tandem.

The DTT rate category is composed of a monthly fixed rate and a monthly per-mile rate based on the facility provided, (i.e., Voice Grade, DS1 or DS3). The fixed rate provides the circuit equipment at the ends of the transmission paths. The per-mile rate provides the transmission facilities, including intermediate transmission circuit equipment, between the end points of the circuit. The DTT rate is the sum of the fixed rate and the per-mile rate. For purposes of determining the per-mile rate, mileage will be measured as airline mileage using the V & H coordinates method. Mileage measurement rules are set forth in 6.7.11, following. The types of facilities available for DTT are described in 2., following.

##### c. Switched Transport TST Rate Category

TST provides the transmission facilities between an access tandem and end offices subtending that tandem utilizing tandem switching functions. TST is not available from or to a Company Hub. TST consists of circuits used in common by multiple customers from the access tandem to an end office. For TST, the Company will determine the type of facilities to the end office(s) based on the customer's order for service on a per-trunk basis. For examples of Tandem Switched Transport see Section 2.4.7 preceding.

(C)  
(C)

The TST rate category is composed of the rate elements set forth in (1) through (4), following. Rates and charges are set forth in 6.8, following.

**6. SWITCHED ACCESS SERVICE**

**6.8 RATES AND CHARGES**

**6.8.1 SWITCHED TRANSPORT (Cont'd)**

C. Tandem-Switched Transport Usage Rates

<b>MILEAGE BANDS</b>	<b>RATE PER ACCESS MINUTE</b>		
	<b>FIXED</b>	<b>PER MILE</b>	
1. Tandem Transmission			
• Originating			
0	-	-	
Over 0 to 8	\$0.000410	\$0.000010	
Over 8 to 25	0.000410	0.000012	
Over 25 to 50	0.000410	0.000015	
Over 50	0.000410	0.000018	
• Terminating – Tandem 3rd Party			
0	-	-	(C)
Over 0 to 8	0.000240	0.000030	
Over 8 to 25	0.000240	0.000030	
Over 25 to 50	0.000240	0.000030	
Over 50	0.000240	0.000030	
• Terminating – Tandem End Office			
0	-	-	(N)
Over 0 to 8	0.000000	0.000000	
Over 8 to 25	0.000000	0.000000	
Over 25 to 50	0.000000	0.000000	
Over 50	0.000000	0.000000	(N)
			(M)
			(M)

(M) Material moved to Page 187.1

**6. SWITCHED ACCESS SERVICE**

**6.8 RATES AND CHARGES**

**6.8.1 SWITCHED TRANSPORT**

C. Tandem-Switched Transport Usage Rates (Cont'd)

	<b>RATE PER ACCESS MINUTE</b>	<b>(M)</b>
2. Tandem Switching Charge:		
Originating	\$0.002450	
Terminating – Tandem 3rd Party	0.002252	(C-M)
Terminating – Tandem End Office	0.000700	(N)
3. Common Transport Multiplexing:		
Originating	0.000030	(M)
Terminating – Tandem 3rd Party	0.000036	(C-M)
Terminating – Tandem End Office	0.000000	(N)
	<b>MONTHLY RATE</b>	<b>(M)</b>
4. Access Tandem Trunk Port Charge, per port	\$6.00	(M)

(M) Material moved from Page 187.

**6. SWITCHED ACCESS SERVICE**

**6.8 RATES AND CHARGES (Cont'd)**

**6.8.2 LOCAL SWITCHING**

A. Local End Office Switching

	<b>RATE PER ACCESS MINUTE</b>
• Originating	\$0.003479
• Terminating	0.000000 (R)
• End Office Shared Port	
Originating	0.000902
Terminating	0.000000
	<b>MONTHLY RATE</b>
• End Office Dedicated Trunk Port,[1] per trunk	\$3.00

[1] The End Office Dedicated Trunk Port rate was calculated based upon a 50/50 split between originating and terminating traffic using this flat-rated port. The FCC in their FCC 11-161 ICC Transformation order in section 51.907(d)(1) allowed Price Cap Carriers to use an equal split to divide the charge between originating and terminating elements. When the terminating portion of the rate is reduced and then combined with the originating portion of the rate a single flat rate is generated for billing purposes. The Originating portion of the charge is \$3.00.

## Description of Methodology

The following narrative describes the methodology and supporting calculations utilized by CenturyLink to implement the process of reducing terminating switched end office rates to bill-and-keep (not to exceed \$0.0000/MOU) and terminating traffic traversing a tandem switch. When a CenturyLink Price Cap ILEC owns the tandem and a CenturyLink Price Cap ILEC owns the terminating End Office Switch, the tandem switched rates will be considered “Tandem-to-End Office” and will transition to \$0.0007/MOU as required by 47 C.F.R. §51.907(g)<sup>1</sup>, which addresses changes beginning July 1, 2017. All other tandem traffic that traverses a CenturyLink Price Cap ILEC-owned tandem and does not terminate to an end user served by a CenturyLink Price Cap ILEC end office will be considered “Tandem-to- 3<sup>rd</sup> Party” and will continue to be billed at the current Interstate rates, including tandem traffic traversing a CenturyLink Price-Cap ILEC-owned tandem to an affiliated CenturyLink CLEC end office. Tandem-Switched Transport charges associated with traffic traversing a non-CenturyLink Price Cap ILEC-owned tandem, but terminating to a CenturyLink-owned end office will also remain at current Interstate rates. CenturyLink’s supporting calculations utilize the “Access Reduction Spreadsheet” template released by the Federal Communications Commission (“FCC”) on April 24, 2017 for calculating the July 1, 2017 Interstate and Intrastate access rate changes.

The FCC spreadsheet template also provides the methodology for calculating the rate changes and identifies, in detail, the Interstate access rates that are required to be changed consistent with the FCC rules. Step 6 of the USF ICC Transformation Order adjusts Interstate Terminating End Office Access rates down to the target composite rate of \$0.0000/MOU and Tandem-Switched Transport to the target composite rates as discussed above. The Interstate rates will be mirrored on the Intrastate side so that rates will remain in parity.

Section 51.907(g) of the FCC rules required the Access Reduction Spreadsheet to be modified to reflect rate reductions for July 1, 2017. For Price Cap carriers that file Interstate tariffs assessing a single rate applicable in different states, the Interstate demand utilized shall be the sum of the demand for all of the states included in the tariff, rather than making separate state-by-state calculations. For companies with a single rate in multiple states, the calculations are done at the regional level and the regional rates are mirrored in each study area<sup>2</sup>. For individual study areas, the calculations are done at the study area level. An overview of the steps and methodology used to reduce terminating End Office and Tandem-Switched Transport access rates are as follows:

---

<sup>1</sup> Per guidance from FCC Staff.

<sup>2</sup> See footnote No. 27 in clarification order: Connect America Fund, et al., DA 14-434, WC Docket No. 10-90 et al.



1. Lower the terminating End Office Switched Access Rates to bring the 2017 composite rate to zero.
2. Establish the 2011 Baseline Composite Terminating Tandem-Switched Transport Access Rate by splitting the Tandem- Switched Transport demand between various traffic scenarios. Tandem-to-End Office traffic is the affiliate-terminated traffic that the Order requires for further transitions/reductions. This traffic was identified by using a relationship of 2016 traffic and applied to the demand already loaded in the model. Dedicated Tandem Trunk Ports are not part of the transition per Rule 51.903(i) that expressly excludes rate elements in Part 69.111.
3. Calculate the 2017 Target Composite Terminating Tandem-Switched Transport Access Rate for Tandem-to-End Office by reducing the 2011 Baseline Composite Terminating Tandem-Switched Rate to not exceed \$0.0007/MOU.
4. Calculate the individual Interstate Terminating Tandem-Switched Access Tandem-to-End Office rate levels such that the reduced rates and demand will equal the 2017 Target Composite Terminating Tandem-Switched Access Rate.
5. Set Intrastate Terminating End Office and Tandem-Switched Transport Access rates equal to their functionally equivalent Interstate rates.
6. Prepare Intrastate and Interstate tariff documents as required by each tariff jurisdiction.

## ***CERTIFICATION***

I am Vice President – Regulatory Operations for CenturyLink. I hereby certify that I have overall responsibility for supervision of the personnel who prepare all of the data supporting the CenturyLink Operating Companies– July 1, 2017 Annual Access Charge Tariff Filing bearing Tariff F.C.C. Nos. 1, 2, 3, 6, 7, 8, 9 and 11 for all issuing carriers and that I am authorized to execute this certification. Based upon the information provided to me by employees responsible for the preparation of, or for the supervision of the preparation of, the data submitted in support of the Tariff Review Plan information contained herewith, I hereby certify that the data has been examined and reviewed and is true, correct and complete to the best of my knowledge and belief.

Further, based upon the information provided to me by employees responsible for the preparation of, or for the supervision of the preparation of, the data submitted in support of the Eligible Recovery for Price Cap Carriers and Access Recovery Charge information contained herewith, I hereby certify that the data has been examined and reviewed and is true, correct and complete to the best of my knowledge and belief, that the CenturyLink Operating Companies are not seeking duplicative recovery in the state jurisdiction for any Eligible Recovery subject to the recovery mechanism, and that CenturyLink Operating Companies have complied with sections 51.915(d), 51.915(e) and 51.915(f) of the Commission's rules.

May 15, 2017



---

Jeff Glover  
Vice President – Regulatory Operations

Contact Person: Gary Kepley  
Director, Regulatory Operations  
Telephone Number: (913) 353-7080