



e-FILING REPORT COVER SHEET

Send completed Cover Sheet and the Report in an email addressed to:  
[PUC.FilingCenter@state.or.us](mailto:PUC.FilingCenter@state.or.us)

REPORT NAME: Qualifying Facilities Transactions

COMPANY NAME: Pacific Power

DOES REPORT CONTAIN CONFIDENTIAL INFORMATION? No Yes

If yes, please submit only the cover letter electronically. Submit confidential information as directed in OAR 860-001-0070 or the terms of an applicable protective order.

If known, please select designation: RE (Electric) RG (Gas) RW (Water) RO (Other)

Report is required by: OAR 860-029-0020

Statute

Order

Other

Is this report associated with a specific docket/case? No Yes

If yes, enter docket number: RE 142

List applicable Key Words for this report to facilitate electronic search:  
Qualifying Facility

**DO NOT electronically file with the PUC Filing Center:**

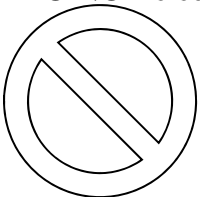

- Annual Fee Statement form and payment remittance or
- OUS or RSPF Surcharge form or surcharge remittance or
- Any other Telecommunications Reporting or
- Any daily safety or safety incident reports or
- Accident reports required by ORS 654.715

**Please file the above reports according to their individual instructions.**

June 14, 2017

***VIA ELECTRONIC FILING  
AND OVERNIGHT DELIVERY***

Public Utility Commission of Oregon  
201 High Street SE, Suite 100  
Salem, OR 97301-3398

**RE: RE 142 - Informational Filing on Qualifying Facility Transactions**

In accordance with OAR 860-029-0020(1), PacifiCorp d/b/a Pacific Power submits an electronic copy of the executed qualifying facility (QF) power purchase agreement (PPA), as listed on Attachment A. The non-confidential attachment is provided on the enclosed CD.

QF PPAs are entered into under the Public Utility Regulatory Policies Act of 1978 (PURPA). Under OAR 860-029-0020(1), public utilities must file a true copy of executed PPAs between the utility and PURPA QFs.

If you have any questions, please contact Natasha Siores at (503) 813-6583.

Sincerely,



Etta Lockey  
Vice President, Regulation

Enclosures

cc: Brittany Andrus, PUC Staff

RE 142

Informational Filing

Qualifying Facility (QF) Agreements

June 14, 2017

Attachment A

Oregon / PacifiCorp

Docket: RE 142 – Informational Filing

Qualifying Facility (QF) Agreements per OAR 860-029-0020(1)

<p><b>Oregon Qualifying Facility (QF) Agreements</b> <b>** NON-CONFIDENTIAL **</b></p>
<p>Stahlbush Island Farms Inc.</p>

**NON-FIRM POWER PURCHASE AGREEMENT**

**BETWEEN**

**STAHLBUSH ISLAND FARMS, INC.**

**[an existing Oregon, Non-Firm Qualifying Facility with 10,000 kW Facility Capacity  
Rating, or Less]**

**AND**

**PACIFICORP**

Section 1: Definitions .....	2
Section 2: Term; Effective Date .....	5
Section 3: Representations and Warranties.....	5
Section 4: Delivery of Power .....	7
Section 5: Purchase Prices .....	8
Section 6: Operation and Control .....	8
Section 7: Metering.....	9
Section 8: Billings, Computations, and Payments .....	9
Section 9: Defaults and Remedies .....	10
Section 10: Indemnification and Liability .....	12
Section 11: Insurance ( <i>Facilities over 200kW only</i> ) .....	13
Section 12: Force Majeure .....	14
Section 13: Several Obligations.....	14
Section 14: Choice of Law.....	15
Section 15: Partial Invalidity .....	15
Section 16: Waiver.....	15
Section 17: Governmental Jurisdictions and Authorizations.....	15
Section 18: Repeal of PURPA .....	15
Section 19: Successors and Assigns .....	15
Section 20: Entire Agreement.....	16
Section 21: Notices .....	16

- EXHIBIT A: DESCRIPTION OF SELLER'S FACILITY
- EXHIBIT B: SELLER'S INTERCONNECTION FACILITIES
- EXHIBIT C: REQUIRED FACILITY DOCUMENTS
- EXHIBIT D: SELLER'S ENERGY DELIVERY SCHEDULE
- EXHIBIT E: SELLER AUTHORIZATION TO RELEASE GENERATION DATA TO PACIFICORP
- EXHIBIT F: STANDARD AVOIDED COST RATES SCHEDULE AND PRICING SUMMARY TABLE

## NON-FIRM POWER PURCHASE AGREEMENT

THIS NON-FIRM POWER PURCHASE AGREEMENT, entered into this 25<sup>th</sup> day of May, 2017, is between **STAHLBUSH ISLAND FARMS, INC.**, “**Seller**” and PacifiCorp (d/b/a Pacific Power & Light Company), an Oregon corporation acting in its regulated utility capacity, “**PacifiCorp.**” (Seller and PacifiCorp are referred to individually as a “**Party**” or collectively as the “**Parties**”).

### RECITALS

A. Seller owns, operates and maintains a biogas digester Facility for the generation of electric power, including interconnection facilities, located in Corvallis, Linn County, Oregon with a Facility Capacity Rating of 1,600 kilowatts (kW) as further described in **Exhibit A** and **Exhibit B (“Facility”)**; and

B. The Parties desire to enter into this Agreement to replace in its entirety the power purchase agreement dated September 30, 2014 (the “**PPA**”), which terminates on May 31, 2017; and

C. Seller intends to continue to deliver Net Output under this Agreement; and

D. Seller intends to continue to operate the Facility as a Qualifying Facility, and is deemed to have established commercial operation as of June 24, 2009; and

E. Seller estimates that the average annual Net Energy to be delivered by the Facility to PacifiCorp is 463,330 kilowatt-hours (kWh), which amount of energy PacifiCorp will include in its resource planning; and

F. Seller shall (choose one)  sell all Net Output to PacifiCorp and purchase its full electric requirements from PacifiCorp  sell Net Output surplus to its needs at the Facility site to PacifiCorp and purchase partial electric requirements service from PacifiCorp, in accordance with the terms and conditions of this Agreement; and

G. This Agreement is a “New QF Contract” under the PacifiCorp Inter-Jurisdictional Cost Allocation Revised Protocol in effect at the Effective Date.

## AGREEMENT

NOW, THEREFORE, the Parties mutually agree as follows:

### SECTION 1: DEFINITIONS

When used in this Agreement, the following terms shall have the following meanings:

1.1 “**As-built Supplement**” shall be a supplement to **Exhibit A** and **Exhibit B**, provided by Seller following completion of construction of the Facility, describing the Facility as actually built.

1.2 “**Average Annual Generation**” shall have the meaning set forth in Section 4.2.

1.3 “**Billing Period**” means, unless otherwise agreed to, the time period between PacifiCorp's consecutive readings of its power purchase billing meter at the Facility in the normal course of PacifiCorp's business. Such periods typically range between twenty-seven (27) and thirty-four (34) days and may not coincide with calendar months.

1.4 [Intentionally Omitted]

1.5 “**Commission**” means the Public Utility Commission of Oregon.

1.6 “**Contract Price**” means the applicable price for Net Output, stated in Section 5.1.

1.7 “**Contract Year**” means a twelve (12) month period commencing at 00:00 hours Pacific Prevailing Time (“PPT”) on January 1 and ending on 24:00 hours PPT on December 31; *provided, however*, that the first Contract Year shall commence on the Commercial Operation Date and end on the next succeeding December 31, and the last Contract Year shall end on the Termination Date.

1.8 “**Effective Date**” shall have the meaning set forth in Section 2.1.

1.9 “**Energy Delivery Schedule**” shall have the meaning set forth in Section 4.3.

1.10 “**Environmental Attributes**” shall mean any and all claims, credits, benefits, emissions reductions, offsets, and allowances, howsoever entitled, resulting from the avoidance of the emission of any gas, chemical, or other substance to the air, soil or water. Environmental Attributes include but are not limited to: (1) any avoided emissions of pollutants to the air, soil, or water such as (subject to the foregoing) sulfur oxides (SOx), nitrogen oxides (NOx), carbon monoxide (CO), and other pollutants; and (2) any avoided emissions of carbon dioxide (CO<sub>2</sub>), methane (CH<sub>4</sub>), and other greenhouse gases (GHGs) that have been determined by the United Nations Intergovernmental Panel on Climate Change to contribute to the actual or potential threat of altering the Earth's climate by trapping heat in the atmosphere.

1.11 “**Facility**” shall have the meaning set forth in Recital A.



1.12 “**Facility Capacity Rating**” means the sum of the Nameplate Capacity Ratings for all generators comprising the Facility.

1.13 “**FERC**” means the Federal Energy Regulatory Commission, or its successor.

1.14 “**Generation Interconnection Agreement**” means the generation interconnection agreement to be entered into separately between Seller and PacifiCorp’s transmission or distribution department, as applicable, providing for the construction, operation, and maintenance of PacifiCorp’s interconnection facilities required to accommodate deliveries of Seller’s Net Output if the Facility is to be interconnected directly with PacifiCorp rather than another electric utility.

1.15 “**Green Tags**” means (1) the Environmental Attributes associated with all Net Output, together with (2) all WREGIS Certificates; and (3) the Green Tag Reporting Rights associated with such energy, Environmental Attributes and WREGIS Certificates, however commercially transferred or traded under any or other product names, such as "Renewable Energy Credits," "Green-e Certified", or otherwise. One (1) Green Tag represents the Environmental Attributes made available by the generation of one (1) MWh of energy from the Facility. Provided however, that “Green Tags” do not include Environmental Attributes that are greenhouse gas offsets from methane capture not associated with the generation of electricity and not needed to ensure that there are zero net emissions associated with the generation of electricity.

1.16 “**Green Tag Reporting Rights**” means the exclusive right of a purchaser of Green Tags to report exclusive ownership of Green Tags in compliance with federal or state law, if applicable, and to federal or state agencies or other parties at such purchaser's discretion, and include reporting under Section 1605(b) of the Energy Policy Act of 1992, or under any present or future domestic, international, or foreign emissions trading program or renewable portfolio standard.

1.17 “**Licensed Professional Engineer**” means a person acceptable to PacifiCorp in its reasonable judgment who is licensed to practice engineering in the state of Oregon, who has no economic relationship, association, or nexus with the Seller, and who is not a representative of a consulting engineer, contractor, designer or other individual involved in the development of the Facility, or of a manufacturer or supplier of any equipment installed in the Facility. Such Licensed Professional Engineer shall be licensed in an appropriate engineering discipline for the required certification being made.

1.18 “**Nameplate Capacity Rating**” means the full-load electrical quantities assigned by the designer to a generator and its prime mover or other piece of electrical equipment, such as transformers and circuit breakers, under standardized conditions, expressed in amperes, kilovolt-amperes, kilowatts, volts, or other appropriate units. Usually indicated on a nameplate attached to the individual machine or device.

1.19 “**Net Output**” means all energy produced by the Facility, less station use and less transformation and transmission losses and other adjustments (e.g., Seller’s load other than station

use), if any. For purposes of calculating payment under this Agreement, Net Output of energy shall be the amount of energy flowing through the Point of Delivery.

1.20 **“Point of Delivery”** means the high side of the Seller’s step-up transformer(s) located at the point of interconnection between the Facility and PacifiCorp’s distribution/transmission system, as specified in the Generation Interconnection Agreement, or, if the Facility is not interconnected directly with PacifiCorp, the point at which another utility will deliver the Net Output to PacifiCorp as specified in **Exhibit B**.

1.21 **“Prime Rate”** means the publicly announced prime rate for commercial loans to large businesses with the highest credit rating in the United States in effect from time to time quoted by Citibank, N.A. If a Citibank, N.A. prime rate is not available, the applicable Prime Rate shall be the announced prime rate for commercial loans in effect from time to time quoted by a bank with \$10 billion or more in assets in New York City, New York, selected by the Party to whom interest based on the Prime Rate is being paid.

1.22 **“Prudent Electrical Practices”** means any of the practices, methods and acts engaged in or approved by a significant portion of the electrical utility industry or any of the practices, methods or acts, which, in the exercise of reasonable judgment in the light of the facts known at the time a decision is made, could have been expected to accomplish the desired result at the lowest reasonable cost consistent with reliability, safety and expedition. Prudent Electrical Practices is not intended to be limited to the optimum practice, method or act to the exclusion of all others, but rather to be a spectrum of possible practices, methods or acts.

1.23 **“QF”** means **“Qualifying Facility,”** as that term is defined in the FERC regulations (codified at 18 CFR Part 292) in effect on the Effective Date.

1.24 **“Renewable Resource Deficiency Period”** means the period from January 1, 2028 forward.

1.25 **“Renewable Resource Sufficiency Period”** means the period from the Effective Date through December 31, 2027.

1.26 **“Required Facility Documents”** means all licenses, permits, authorizations, and agreements, including a Generation Interconnection Agreement or equivalent, necessary for construction, operation, and maintenance of the Facility consistent with the terms of this Agreement, including without limitation those set forth in **Exhibit C**.

1.27 **“Standard Avoided Cost Rates Schedule”** means the Commission-approved Standard Avoided Cost Rates Schedule of Pacific Power & Light Company, providing pricing options for Base Load and Wind Qualifying Facilities of 10,000 kW or less, or Fixed and Tracking Solar Qualifying Facilities of 3,000 kW or less, which is in effect on the Effective Date of this Agreement. A copy of that Standard Avoided Cost Rates Schedule is attached as **Exhibit F**.

1.28 **“Termination Date”** shall have the meaning set forth in Section 2.3.

1.29 “**WREGIS**” means the Western Renewable Energy Generation Information System or successor organization in case WREGIS is ever replaced.

1.30 “**WREGIS Certificate**” means “Certificate” as defined by WREGIS in the WREGIS Operating Rules dated July 15, 2013.

1.31 [Intentionally Omitted]

## **SECTION 2: TERM; EFFECTIVE DATE**

2.1 This Agreement shall become effective after execution by both Parties (“**Effective Date**”). Delivery of Net Output under this Agreement begins at 12:01 AM June 1, 2017.

2.2 By the Effective Date, Seller shall provide PacifiCorp with the Required Facility Documents.

2.3 Except as otherwise provided herein, this Agreement shall terminate on May 31, 2019 (“**Termination Date**”).

## **SECTION 3: REPRESENTATIONS AND WARRANTIES**

3.1 PacifiCorp represents, covenants, and warrants to Seller that:

- 3.1.1 PacifiCorp is duly organized and validly existing under the laws of the State of Oregon.
- 3.1.2 PacifiCorp has the requisite corporate power and authority to enter into this Agreement and to perform according to the terms of this Agreement.
- 3.1.3 PacifiCorp has taken all corporate actions required to be taken by it to authorize the execution, delivery and performance of this Agreement and the consummation of the transactions contemplated hereby.
- 3.1.4 The execution and delivery of this Agreement does not contravene any provision of, or constitute a default under, any indenture, mortgage, or other material agreement binding on PacifiCorp or any valid order of any court, or any regulatory agency or other body having authority to which PacifiCorp is subject.
- 3.1.5 This Agreement is a valid and legally binding obligation of PacifiCorp, enforceable against PacifiCorp in accordance with its terms (except as the enforceability of this Agreement may be limited by bankruptcy, insolvency, bank moratorium or similar laws affecting creditors’ rights generally and laws restricting the availability of equitable remedies and except as the enforceability of this Agreement may be subject to general principles of

equity, whether or not such enforceability is considered in a proceeding at equity or in law).

3.2 Seller represents, covenants, and warrants to PacifiCorp that:

- 3.2.1 Seller is a [corporation, partnership, or limited liability company] duly organized and validly existing under the laws of \_\_\_\_\_.
- 3.2.2 Seller has the requisite power and authority to enter into this Agreement and to perform according to the terms hereof, including all required regulatory authority to make wholesale sales from the Facility.
- 3.2.3 Seller has taken all actions required to authorize the execution, delivery and performance of this Agreement and the consummation of the transactions contemplated hereby.
- 3.2.4 The execution and delivery of this Agreement does not contravene any provision of, or constitute a default under, any indenture, mortgage, or other material agreement binding on Seller or any valid order of any court, or any regulatory agency or other body having authority to which Seller is subject.
- 3.2.5 This Agreement is a valid and legally binding obligation of Seller, enforceable against Seller in accordance with its terms (except as the enforceability of this Agreement may be limited by bankruptcy, insolvency, bank moratorium or similar laws affecting creditors' rights generally and laws restricting the availability of equitable remedies and except as the enforceability of this Agreement may be subject to general principles of equity, whether or not such enforceability is considered in a proceeding at equity or in law).
- 3.2.6 The Facility is and shall for the term of this Agreement continue to be a QF, and Seller will operate the Facility in a manner consistent with its FERC QF certification. Seller has provided to PacifiCorp the appropriate QF certification (which may include a FERC self-certification) prior to PacifiCorp's execution of this Agreement. At any time during the term of this Agreement, PacifiCorp may require Seller to provide PacifiCorp with evidence satisfactory to PacifiCorp in its reasonable discretion that the Facility continues to qualify as a QF under all applicable requirements and, if PacifiCorp is not satisfied that the Facility qualifies for such status, a written legal opinion from an attorney who is (a) in good standing in the state of Oregon, and (b) who has no economic relationship, association or nexus with the Seller or the Facility, stating that the Facility is a QF and providing sufficient proof (including copies of all documents and data as PacifiCorp may request) demonstrating that Seller has maintained and will continue to maintain the Facility as a QF.

3.2.7 Compliance with Ownership Requirements in Commission Proceedings No. UM 1129 and UM 1610. Seller will not make any changes in its ownership, control, or management during the term of this Agreement that would cause it to not be in compliance with the definition of a Small Cogeneration Facility or Small Power Production Facility provided in PacifiCorp's Standard Avoided Cost Rates Schedule approved by the Commission at the time this Agreement is executed. Seller will provide, upon request by PacifiCorp not more frequently than every 36 months, such documentation and information as reasonably may be required to establish Seller's continued compliance with such Definition. PacifiCorp agrees to take reasonable steps to maintain the confidentiality of any portion of the above-described documentation and information that the Seller identifies as confidential except PacifiCorp will provide all such confidential information the Public Utility Commission of Oregon upon the Commission's request. These ownership requirements, as well as the dispute resolution provision governing any disputes over a QF's entitlement to the standard rates and standard contract with respect to the requirements, are detailed in PacifiCorp's Standard Avoided Cost Rates Schedule.

3.3 Notice. If at any time during this Agreement, any Party obtains actual knowledge of any event or information which would have caused any of the representations and warranties in this Section 3 to have been materially untrue or misleading when made, such Party shall provide the other Party with written notice of the event or information, the representations and warranties affected, and the action, if any, which such Party intends to take to make the representations and warranties true and correct. The notice required pursuant to this Section shall be given as soon as practicable after the occurrence of each such event.

#### **SECTION 4: DELIVERY OF POWER**

4.1 Commencing on the Commercial Operation Date, unless otherwise provided herein, Seller will sell and PacifiCorp will purchase all Net Output from the Facility delivered to the Point of Delivery..

4.2 Average Annual Generation. Seller estimates that the Facility will generate, on average, 463,330 kWh per Contract Year ("**Average Annual Generation**"). Seller may, upon at least six months prior written notice, modify the Average Annual Generation every other Contract Year.

4.3 Energy Delivery Schedule. Seller has provided a monthly schedule of Net Output expected to be delivered by the Facility ("**Energy Delivery Schedule**"), attached hereto as **Exhibit D**.

4.4 [Intentionally Omitted]

## **SECTION 5: PURCHASE PRICES**

5.1 Net Output. For all Net Output delivered to the Point of Delivery, PacifiCorp shall pay Seller 93 percent of a blended market index price for day-ahead firm energy at Mid-Columbia, California Oregon Border (COB), Four Corners and Palo Verde market indices as reported by the Intercontinental Exchange (ICE), for the On-Peak and Off-Peak periods. PacifiCorp shall document its calculation of the blended rate, upon request, to Seller. Such payment will be accomplished by adjustments pursuant to Section 8.1.

5.2 Environmental Attributes. PacifiCorp waives any claim to Seller's ownership of Environmental Attributes under this Agreement. Environmental Attributes include, but are not limited to, Green Tags, Green Certificates, Renewable Energy Credits (RECs) and Tradable Renewable Certificates (TRCs) (as those terms are commonly used in the regional electric utility industry) directly associated with the production of energy from the Seller's Facility.

## **SECTION 6: OPERATION AND CONTROL**

6.1 As-Built Supplement. Upon completion of initial (and any subsequent) construction of the Facility, Seller shall provide PacifiCorp an As-built Supplement to specify the actual Facility as built. The As-built Supplement must be reviewed and approved by PacifiCorp, which approval shall not unreasonably be withheld, conditioned or delayed.

6.2 Incremental Utility Upgrades. At start-up (and at any other time upon at least six months' prior written notice), Seller may increase Net Output, if such increase is due to normal variances in estimated versus actual performance, changed Facility operations, or improvements in Facility efficiency. Seller may not increase Net Output under this Agreement by installing additional generating units.

6.3 Seller shall operate and maintain the Facility in a safe manner in accordance with the Generation Interconnection Agreement (if applicable), Prudent Electrical Practices and in accordance with the requirements of all applicable federal, state and local laws and the National Electric Safety Code as such laws and code may be amended from time to time. PacifiCorp shall have no obligation to purchase Net Output from the Facility to the extent the interconnection between the Facility and PacifiCorp's electric system is disconnected, suspended or interrupted, in whole or in part, pursuant to the Generation Interconnection Agreement, or to the extent generation curtailment is required as a result of Seller's non-compliance with the Generation Interconnection Agreement. PacifiCorp shall have the right to inspect the Facility to confirm that Seller is operating the Facility in accordance with the provisions of this Section 6.3 upon reasonable notice to Seller. Seller is solely responsible for the operation and maintenance of the Facility. PacifiCorp shall not, by reason of its decision to inspect or not to inspect the Facility, or by any action or inaction taken with respect to any such inspection, assume or be held responsible for any liability or occurrence arising from the operation and maintenance by Seller of the Facility.

6.4 Scheduled Outages. Seller may cease operation of the entire Facility or individual units, if applicable, for maintenance or other purposes. Seller shall exercise reasonable efforts to notify PacifiCorp of planned outages at least ninety (90) days prior.

6.5 Unplanned Outages. In the event of an unscheduled outage or curtailment exceeding twenty-five (25) percent of the Facility Capacity Rating (other than curtailments due to lack of motive force) expected to last more than 48 hours, Seller reasonably shall notify PacifiCorp of the unscheduled outage or curtailment, the time when such has occurred or will occur, and the anticipated duration.

## **SECTION 7: METERING**

7.1 PacifiCorp shall design, furnish, install, own, inspect, test, maintain and replace all metering equipment required pursuant to the Generation Interconnection Agreement, if applicable.

7.2 Metering shall be performed at the location and in a manner consistent with this Agreement and as specified in the Generation Interconnection Agreement, or, if the Net Output is to be wheeled to PacifiCorp by another utility, metering will be performed in accordance with the terms of PacifiCorp's interconnection agreement with such other utility. All quantities of energy purchased hereunder shall be adjusted to account for electrical losses, if any between the point of metering and the Point of Delivery, so that the purchased amount reflects the net amount of energy flowing into PacifiCorp's system at the Point of Delivery.

7.3 PacifiCorp shall periodically inspect, test, repair and replace the metering equipment as provided in the Generation Interconnection Agreement, if applicable. If the Net Output is to be wheeled to PacifiCorp by another utility, meter inspection, testing, repair and replacement will be performed in accordance with the terms of PacifiCorp's interconnection agreement with such utility. If any of the inspections or tests discloses an error exceeding two percent (2%), either fast or slow, proper correction, based upon the inaccuracy found, shall be made of previous readings for the actual period during which the metering equipment rendered inaccurate measurements if that period can be ascertained. If the actual period cannot be ascertained, the proper correction shall be made to the measurements taken during the time the metering equipment was in service since last tested, but not exceeding three (3) Billing Periods, in the amount the metering equipment shall have been shown to be in error by such test. Any correction in billings or payments resulting from a correction in the meter records shall be made in the next monthly billing or payment rendered following the repair of the meter.

## **SECTION 8: BILLINGS, COMPUTATIONS, AND PAYMENTS**

8.1 On or before the thirtieth (30th) day following the end of each Billing Period, PacifiCorp shall send to Seller payment for Seller's deliveries of Net Output to PacifiCorp, together with computations supporting such payment. PacifiCorp may offset any such payment to reflect amounts owing from Seller to PacifiCorp pursuant to this Agreement, the Generation Interconnection Agreement, or any other agreement between the Parties.

8.2 Corrections. PacifiCorp shall have up to eighteen months to adjust any payment made pursuant to Section 8.1. In the event PacifiCorp determines it has overpaid Seller, PacifiCorp may adjust Seller's future payment accordingly in order to recapture any overpayment in a reasonable time.

8.3 Any amounts owing after the due date thereof shall bear interest at the Prime Rate plus two percent (2%) from the date due until paid; *provided, however*, that the interest rate shall at no time exceed the maximum rate allowed by applicable law.

## **SECTION 9: DEFAULTS AND REMEDIES**

9.1 Events of Default. The following events shall constitute defaults under this Agreement:

- 9.1.1 Breach of Material Term. Failure of a Party to perform any material obligation imposed upon that Party by this Agreement (including but not limited to failure by Seller to meet any deadline set forth in Section 2) or breach by a Party of a representation or warranty set forth in this Agreement.
- 9.1.2 Default on Other Agreements. Seller's failure to cure any default under any commercial or financing agreements or instrument (including the Generation Interconnection Agreement) within the time allowed for a cure under such agreement or instrument.
- 9.1.3 Insolvency. A Party (a) makes an assignment for the benefit of its creditors; (b) files a petition or otherwise commences, authorizes or acquiesces in the commencement of a proceeding or cause of action under any bankruptcy or similar law for the protection of creditors, or has such a petition filed against it and such petition is not withdrawn or dismissed within sixty (60) days after such filing; (c) becomes insolvent; or (d) is unable to pay its debts when due.



9.2 Notice; Opportunity to Cure.

9.2.1 Notice. In the event of any default hereunder, the non-defaulting Party must notify the defaulting Party in writing of the circumstances indicating the default and outlining the requirements to cure the default.

9.2.2 Opportunity to Cure. A Party defaulting under Section 9.1.1 or 9.1.4 shall have thirty (30) days to cure after receipt of proper notice from the non-defaulting Party. For such a default *not* resulting from failure of Seller to meet any deadline set forth in Section 2, this thirty (30) day period shall be extended by an additional ninety (90) days if (a) the failure cannot reasonably be cured within the thirty (30) day period despite diligent efforts, (b) the default is capable of being cured within the additional ninety (90) day period, and (c) the defaulting Party commences the cure within the original thirty (30) day period and is at all times thereafter diligently and continuously proceeding to cure the failure. For such a default resulting from failure of Seller to meet any deadline set forth in Section 2, this thirty (30) day period shall be extended to one (1) year from receipt of proper notice if (a) the failure cannot reasonably be cured within the thirty (30) day period despite diligent efforts, (b) the default is capable of being cured within the one (1) year period, and (c) the defaulting Party commences the cure within the original thirty (30) day period and is at all times thereafter diligently and continuously proceeding to cure the failure. If Seller defaults under Section 9.1.4, Seller shall have one (1) year in which to cure the default during which time Seller shall pay PacifiCorp damages as provided for in Section 11.4.

9.3 Termination.

9.3.1 Notice of Termination. If a default described herein has not been cured within the prescribed time above, the non-defaulting Party may terminate this Agreement at its sole discretion by delivering written notice to the other Party and may pursue any and all legal or equitable remedies provided by law or pursuant to this Agreement. Subject to the one (1) year cure period in Section 11.2.2, PacifiCorp may terminate the Agreement for a default under Section 11.1.5 regardless of PacifiCorp's resource sufficiency/deficiency position. PacifiCorp may not terminate for a default under Section 11.1.6 unless such default is material. The rights provided in this Section 9 are cumulative such that the exercise of one or more rights shall not constitute a waiver of any other rights. Further, the Parties may by mutual written agreement amend this Agreement in lieu of a Party's exercise of its right to terminate.

9.3.2 In the event this Agreement is terminated because of Seller's default and Seller wishes to again sell Net Output to PacifiCorp following such termination, PacifiCorp in its sole discretion may require that Seller shall

do so subject to the terms of this Agreement, including but not limited to the Contract Price, until the Termination Date (as set forth in Section 2.4). At such time Seller and PacifiCorp agree to execute a written document ratifying the terms of this Agreement.

## **SECTION 10: INDEMNIFICATION AND LIABILITY**

### 10.1 Indemnities.

10.1.1 Indemnity by Seller. Seller shall release, indemnify and hold harmless PacifiCorp, its directors, officers, agents, and representatives against and from any and all loss, fines, penalties, claims, actions or suits, including costs and attorney's fees, both at trial and on appeal, resulting from, or arising out of or in any way connected with (a) the energy delivered by Seller under this Agreement to and at the Point of Delivery, (b) any facilities on Seller's side of the Point of Delivery, (c) Seller's operation and/or maintenance of the Facility, or (d) arising from this Agreement, including without limitation any loss, claim, action or suit, for or on account of injury, bodily or otherwise, to, or death of, persons, or for damage to, or destruction or economic loss of property belonging to PacifiCorp, Seller or others, excepting only such loss, claim, action or suit as may be caused solely by the fault or gross negligence of PacifiCorp, its directors, officers, employees, agents or representatives.

10.1.2 Indemnity by PacifiCorp. PacifiCorp shall release, indemnify and hold harmless Seller, its directors, officers, agents, Lenders and representatives against and from any and all loss, fines, penalties, claims, actions or suits, including costs and attorney's fees, both at trial and on appeal, resulting from, or arising out of or in any way connected with the energy delivered by Seller under this Agreement after the Point of Delivery, including without limitation any loss, claim, action or suit, for or on account of injury, bodily or otherwise, to, or death of, persons, or for damage to, or destruction or economic loss of property, excepting only such loss, claim, action or suit as may be caused solely by the fault or gross negligence of Seller, its directors, officers, employees, agents, Lenders or representatives.

10.2 No Dedication. Nothing in this Agreement shall be construed to create any duty to, any standard of care with reference to, or any liability to any person not a Party to this Agreement. No undertaking by one Party to the other under any provision of this Agreement shall constitute the dedication of that Party's system or any portion thereof to the other Party or to the public, nor affect the status of PacifiCorp as an independent public utility corporation or Seller as an independent individual or entity.

10.3 No Consequential Damages. EXCEPT TO THE EXTENT SUCH DAMAGES ARE INCLUDED IN THE LIQUIDATED DAMAGES, DELAY DAMAGES, COST TO

COVER DAMAGES OR OTHER SPECIFIED MEASURE OF DAMAGES EXPRESSLY PROVIDED FOR IN THIS AGREEMENT, NEITHER PARTY SHALL BE LIABLE TO THE OTHER PARTY FOR SPECIAL, PUNITIVE, INDIRECT, EXEMPLARY OR CONSEQUENTIAL DAMAGES, WHETHER SUCH DAMAGES ARE ALLOWED OR PROVIDED BY CONTRACT, TORT (INCLUDING NEGLIGENCE), STRICT LIABILITY, STATUTE OR OTHERWISE.

**SECTION 11: INSURANCE (FACILITIES OVER 200KW ONLY)**

11.1 Certificates. Prior to connection of the Facility to PacifiCorp's electric system, or another utility's electric system if delivery to PacifiCorp is to be accomplished by wheeling, Seller shall secure and continuously carry insurance in compliance with the requirements of this Section. Seller shall provide PacifiCorp insurance certificate(s) (of "ACORD Form" or the equivalent) certifying Seller's compliance with the insurance requirements hereunder. Commercial General Liability coverage written on a "claims-made" basis, if any, shall be specifically identified on the certificate. If requested by PacifiCorp, a copy of each insurance policy, certified as a true copy by an authorized representative of the issuing insurance company, shall be furnished to PacifiCorp.

11.2 Required Policies and Coverages. Without limiting any liabilities or any other obligations of Seller under this Agreement, Seller shall secure and continuously carry with an insurance company or companies rated not lower than "B+" by the A.M. Best Company the insurance coverage specified below:

11.2.1 Commercial General Liability insurance, to include contractual liability, with a minimum single limit of \$1,000,000 to protect against and from all loss by reason of injury to persons or damage to property based upon and arising out of the activity under this Agreement.

11.3 The Commercial General Liability policy required herein shall include i) provisions or endorsements naming PacifiCorp, its Board of Directors, Officers and employees as additional insureds, and ii) cross liability coverage so that the insurance applies separately to each insured against whom claim is made or suit is brought, even in instances where one insured claims against or sues another insured.

11.4 All liability policies required by this Agreement shall include provisions that such insurance is primary insurance with respect to the interests of PacifiCorp and that any other insurance maintained by PacifiCorp is excess and not contributory insurance with the insurance required hereunder, and provisions that such policies shall not be canceled or their limits of liability reduced without 1) ten (10) days prior written notice to PacifiCorp if canceled for nonpayment of premium, or 2) thirty (30) days prior written notice to PacifiCorp if canceled for any other reason.

11.5 Insurance coverage provided on a "claims-made" basis shall be maintained by Seller for a minimum period of five (5) years after the completion of this Agreement and for such other length of time necessary to cover liabilities arising out of the activities under this Agreement.

## **SECTION 12: FORCE MAJEURE**

12.1 As used in this Agreement, “Force Majeure” or “an event of Force Majeure” means any cause beyond the reasonable control of the Seller or of PacifiCorp which, despite the exercise of due diligence, such Party is unable to prevent or overcome. By way of example, Force Majeure may include but is not limited to acts of God, fire, flood, storms, wars, hostilities, civil strife, strikes, and other labor disturbances, earthquakes, fires, lightning, epidemics, sabotage, restraint by court order or other delay or failure in the performance as a result of any action or inaction on behalf of a public authority which by the exercise of reasonable foresight such Party could not reasonably have been expected to avoid and by the exercise of due diligence, it shall be unable to overcome, subject, in each case, to the requirements of the first sentence of this paragraph. Force Majeure, however, specifically excludes the cost or availability of fuel or motive force resources to operate the Facility or changes in market conditions that affect the price of energy or transmission. If either Party is rendered wholly or in part unable to perform its obligation under this Agreement because of an event of Force Majeure, that Party shall be excused from whatever performance is affected by the event of Force Majeure to the extent and for the duration of the event of Force Majeure, after which such Party shall re-commence performance of such obligation, provided that:

- 12.1.1 the non-performing Party, shall, within two (2) weeks after the occurrence of the Force Majeure, give the other Party written notice describing the particulars of the occurrence; and
- 12.1.2 the suspension of performance shall be of no greater scope and of no longer duration than is required by the event of Force Majeure; and
- 12.1.3 the non-performing Party uses its best efforts to remedy its inability to perform.

12.2 No obligations of either Party which arose before the Force Majeure causing the suspension of performance shall be excused as a result of the event of Force Majeure.

12.3 Neither Party shall be required to settle any strike, walkout, lockout or other labor dispute on terms which, in the sole judgment of the Party involved in the dispute, are contrary to the Party's best interests.

12.4 PacifiCorp may terminate the Agreement if Seller fails to remedy Seller's inability to perform, due to an event of Force Majeure, within six months after the occurrence of the event.

## **SECTION 13: SEVERAL OBLIGATIONS**

Nothing contained in this Agreement shall ever be construed to create an association, trust, partnership or joint venture or to impose a trust or partnership duty, obligation or liability between the Parties. If Seller includes two or more parties, each such party shall be jointly and severally liable for Seller's obligations under this Agreement.

#### **SECTION 14: CHOICE OF LAW**

This Agreement shall be interpreted and enforced in accordance with the laws of the State of Oregon, excluding any choice of law rules which may direct the application of the laws of another jurisdiction.

#### **SECTION 15: PARTIAL INVALIDITY**

It is not the intention of the Parties to violate any laws governing the subject matter of this Agreement. If any of the terms of the Agreement are finally held or determined to be invalid, illegal or void as being contrary to any applicable law or public policy, all other terms of the Agreement shall remain in effect. If any terms are finally held or determined to be invalid, illegal or void, the Parties shall enter into negotiations concerning the terms affected by such decision for the purpose of achieving conformity with requirements of any applicable law and the intent of the Parties to this Agreement.

#### **SECTION 16: WAIVER**

Any waiver at any time by either Party of its rights with respect to a default under this Agreement or with respect to any other matters arising in connection with this Agreement must be in writing, and such waiver shall not be deemed a waiver with respect to any subsequent default or other matter.

#### **SECTION 17: GOVERNMENTAL JURISDICTIONS AND AUTHORIZATIONS**

This Agreement is subject to the jurisdiction of those governmental agencies having control over either Party or this Agreement. Seller shall at all times maintain in effect all local, state and federal licenses, permits and other approvals as then may be required by law for the construction, operation and maintenance of the Facility, and shall provide upon request copies of the same to PacifiCorp.

#### **SECTION 18: REPEAL OF PURPA**

This Agreement shall not terminate upon the repeal of the PURPA, unless such termination is mandated by federal or state law.

#### **SECTION 19: SUCCESSORS AND ASSIGNS**

This Agreement and all of the terms hereof shall be binding upon and inure to the benefit of the respective successors and assigns of the Parties. No assignment hereof by either Party shall become effective without the written consent of the other Party being first obtained and such consent shall not be unreasonably withheld, conditioned or delayed. Notwithstanding the foregoing, either Party may assign this Agreement without the other Party's consent to a lender as

part of a financing transaction or as part of (a) a sale of all or substantially all of the assigning Party's assets, or (b) a merger, consolidation or other reorganization of the assigning Party.

**SECTION 20: ENTIRE AGREEMENT**

20.1 This Agreement supersedes all prior agreements, proposals, representations, negotiations, discussions or letters, whether oral or in writing, regarding PacifiCorp's purchase of Net Output from the Facility. No modification of this Agreement shall be effective unless it is in writing and signed by both Parties.

20.2 By executing this Agreement, Seller releases PacifiCorp from any claims, known or unknown, that may have arisen prior to the Effective Date.

**SECTION 21: NOTICES**

21.1 All notices except as otherwise provided in this Agreement shall be in writing, shall be directed as follows and shall be considered delivered if delivered in person or when deposited in the U.S. Mail, postage prepaid by certified or registered mail and return receipt requested.

<b>Notices</b>	<b>PacifiCorp</b>	<b>Seller</b>
<b>All Notices</b>	PacifiCorp 825 NE Multnomah Street Portland, OR 97232 Attn: Contract Administration, Suite 600 Phone: (503) 813 - 5380 Facsimile: (503) 813 - 6291 Email: cntadmin@PacifiCorp.com Duns: 00-790-9013 Federal Tax ID Number: 93-0246090	Stahlbush Island Farms, Inc. 3122 Stahlbush Island Rd. Corvallis, OR 97333 Attn: Bill Chambers Phone: (541) 757-1497
<b>All Invoices:</b>	(same as street address above)  Attn: Back Office, Suite 700 Phone: (503) 813 - 5578 Facsimile: (503) 813 - 5580	(same as mailing address above)
<b>Scheduling:</b>	(same as street address above)  Attn: Resource Planning, Suite 600 Phone: (503) 813 - 6090 Facsimile: (503) 813 - 6265	(same as mailing address above)
<b>Payments:</b>	(same as street address above)  Attn: Back Office, Suite 700 Phone: (503) 813 - 5578 Facsimile: (503) 813 - 5580	(same as mailing address above)
<b>Wire Transfer:</b>	Bank One N.A. ABA: ACCT: NAME: PacifiCorp Wholesale	

Notices	PacifiCorp	Seller
<b>Payments:</b>	(same as street address above) Attn: Back Office, Suite 700 Phone: (503) 813 - 5578 Facsimile: (503) 813 - 5580	(same as mailing address above)
<b>Wire Transfer:</b>	Bank One N.A. ABA: ACCT: NAME: PacifiCorp Wholesale	
<b>Credit and Collections:</b>	(same as street address above) Attn: Credit Manager, Suite 700 Phone: (503) 813 - 5684 Facsimile: (503) 813 - 5609	(same as mailing address above)
<b>With Additional Notices of an Event of Default or Potential Event of Default to:</b>	(same as street address above) Attn: PacifiCorp General Counsel Phone: (503) 813-5029 Facsimile: (503) 813-7252	(same as mailing address above)

21.2 The Parties may change the person to whom such notices are addressed, or their addresses, by providing written notices thereof in accordance with this Section 21.

IN WITNESS WHEREOF, the Parties hereto have caused this Agreement to be executed in their respective names as of the date first above written.

PacifiCorp

By: \_\_\_\_\_

Name: Bruce Griswold

Title: Director, Short-term Origination

Date: May 25, 2017

Seller

By: \_\_\_\_\_

Name: WILLIAM D CHAMBERS

Title: PRESIDENT

Date: 2/25/17

**EXHIBIT A**  
**DESCRIPTION OF SELLER'S FACILITY**

[Seller to Complete]

Seller's Facility consists of one (1) generator manufactured by Caterpillar. More specifically, each generator at the Facility is described as:

**Type (synchronous or inductive):** Synchronous

**Model:** G3520

**Number of Phases:** 3

**Rated Output (kW):** 1,600

**Rated Output (kVA):** 2,000

**Rated Voltage (line to line):** 4,160 V

**Rated Current (A):** Stator: 277.6 A; Rotor: \_\_\_\_\_ A

**Maximum kW Output:** 1,600 kW **Maximum kVA Output:** 2,000 kVA

**Minimum kW Output:** 400 kW

**Manufacturer's Guaranteed Cut-in Wind Speed [if applicable]:** NA

---

**Facility Capacity Rating:** 1,600 kW at 90% Capacity Factor

---

Identify the maximum output of the generator(s) and describe any differences between that output and the Nameplate Capacity Rating: Same as above

**Station service requirements, and other loads served by the Facility, if any, are described as follows:** Approximately 175 KW

---

---

**Location of the Facility:** The Facility is located in the vicinity of Corvallis in Linn County, Oregon. The location is more particularly described as follows:

Tax Lot Number of the Facility: 100 Section 12S Range 5W Section 13

**Power factor requirements:**

Rated Power Factor (PF) or reactive load (kVAR): .8 PF



**EXHIBIT B**  
**SELLER'S INTERCONNECTION FACILITIES**

[Seller to provide its own diagram and description]

**POINT OF DELIVERY / SELLER'S INTERCONNECTION FACILITIES**

*Instructions to Seller:*

1. *Include description of point of metering, and Point of Delivery*
2. *Provide interconnection single line drawing of Facility including any transmission facilities on Seller's side of the Point of Delivery.*

1. Point of Delivery is on the high side of the PacifiCorp transformer located on the 20.8 kV Peoria Circuit 4M133 out of the Buchanan Substation
2. One-Line Diagram is attached

Attachment 4 to DGIA

One-line Diagram Depicting the Generating Facility, Interconnection Facilities and Metering Equipment

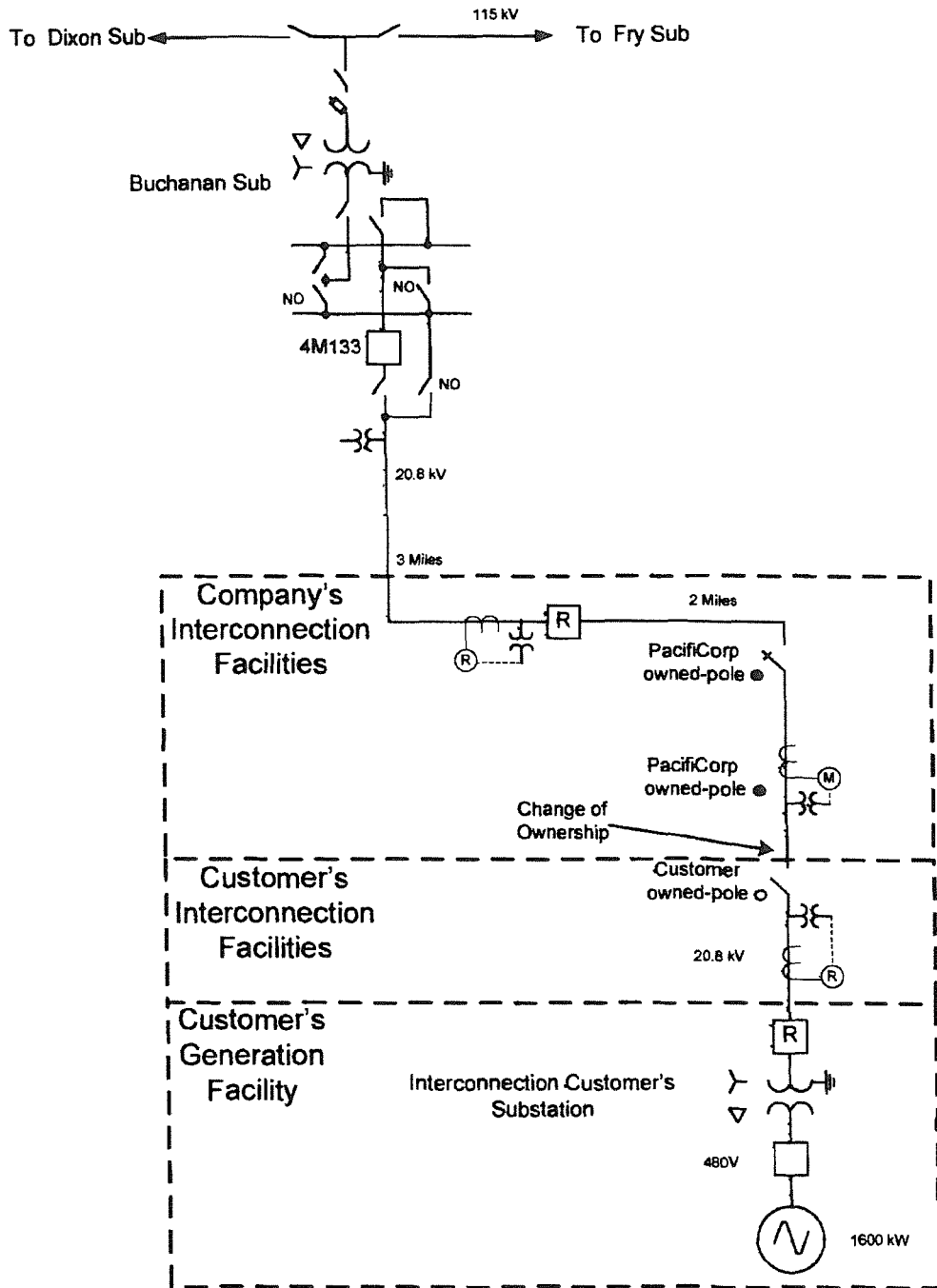

**EXHIBIT C**  
**REQUIRED FACILITY DOCUMENTS**

**REQUIRED OF ALL FACILITIES:**

1. QF Certification – QF08-119-000
2. Interconnection Agreement – Dated October 1, 2008 is still in effect and has been provided
3. Fuel Supply Agreement, if applicable – Not applicable for non-firm power purchase agreement

**EXHIBIT D**  
**SELLER'S ENERGY DELIVERY SCHEDULE**

<b>Month</b>	<b>Average Energy (kWh)</b>
January	17,435
February	2,920
March	57,065
April	204,680
May	181,230
June	0
July	0
August	0
September	0
October	0
November	0
December	0

Estimate based on historic monthly processing plant loads and generation. Generation estimate is the amount in excess of load.

**EXHIBIT E**  
**SELLER AUTHORIZATION TO RELEASE**  
**GENERATION DATA TO PACIFICORP**

*See attached letter.*

**EXHIBIT E**

**Seller Authorization to Release Generation Data to PacifiCorp**

*[Interconnection Customer Letterhead]*

Transmission Services  
Attn: Director, Transmission Services  
825 NE Multnomah, Suite 1600  
Portland, OR 97232

**RE: Stahlbush Island Farms Interconnection Request**

Dear Sir:

Stahlbush Island Farms hereby voluntarily authorizes PacifiCorp's Transmission business unit to share Stahlbush Island Farms' generator interconnection information and generator meter data with Marketing Affiliate employees of PacifiCorp Energy, including, but not limited to those in the Commercial and Trading group. Stahlbush Island Farms acknowledges that PacifiCorp did not provide it any preferences, either operational or rate-related, in exchange for this voluntary consent.

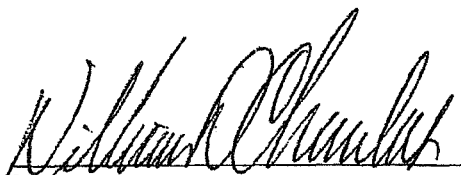
  
Name

*president*  
Title

*5/27/11*  
Date

**EXHIBIT F**  
**STANDARD AVOIDED COST RATES SCHEDULE AND**  
**PRICING SUMMARY TABLE**

**Available**

To owners of Qualifying Facilities making sales of electricity to the Company in the State of Oregon.

**Applicable**

- For power purchased from Base Load and Wind Qualifying Facilities with a nameplate capacity of 10,000 kW or less or that, together with any other electric generating facility using the same motive force, owned or controlled by the same person(s) or affiliated person(s), and located at the same site, has a nameplate capacity of 10,000 kW or less.
- For power purchased Fixed and Tracking Solar Qualifying Facilities with a nameplate capacity of 3,000 kW or less or that, together with any other electric generating facility using the same motive force, owned or controlled by the same person(s) or affiliated person(s), and located at the same site, has a nameplate capacity of 3,000 kW or less.

Owners of these Qualifying Facilities will be required to enter into a written power sales contract with the Company.

**Definitions****Cogeneration Facility**

A facility which produces electric energy together with steam or other form of useful energy (such as heat) which are used for industrial, commercial, heating or cooling purposes through the sequential use of energy.

**Qualifying Facilities**

Qualifying cogeneration facilities or qualifying small power production facilities within the meaning of section 201 and 210 of the Public Utility Regulatory Policies Act of 1978 (PURPA), 16 U.S.C. 796 and 824a-3.

**Qualifying Electricity**

Electricity that meets the requirements of "qualifying electricity" set forth in the Oregon Renewable Portfolio Standards: ORS 469A.010, 469A.020, and 469A.025.

**Renewable Qualifying Facility**

A Qualifying Facility that generates Qualifying Electricity.

**Wind Qualifying Facility**

A Renewable Qualifying Facility that generates Qualifying Electricity using wind as its motive force.

**Baseload Renewable Qualifying Facility**

A Renewable Qualifying Facility that generates Qualifying Electricity using any qualifying resource other than wind or solar.

**Small Power Production Facility**

A facility which produces electric energy using as a primary energy source biomass, waste, renewable resources or any combination thereof and has a power production capacity which, together with other facilities located at the same site, is not greater than 80 megawatts.

(continued)



**Definitions (continued)****On-Peak Hours or Peak Hours**

On-Peak hours are defined as 6:00 a.m. to 10:00 p.m. Pacific Prevailing Time Monday through Saturday, excluding NERC holidays.

Due to the expansions of Daylight Saving Time (DST) as adopted under Section 110 of the U.S. Energy Policy Act of 2005, the time periods shown above will begin and end one hour later for the period between the second Sunday in March and the first Sunday in April and for the period between the last Sunday in October and the first Sunday in November.

**Off-Peak Hours**

All hours other than On-Peak.

**Excess Output**

Excess Output shall mean any increment of Net Output delivered at a rate, on an hourly basis, exceeding the Facility Nameplate Capacity. PacifiCorp shall pay Seller the Off-Peak Price as described and calculated under pricing option 4 (Non-Firm Market Index Avoided Cost Price) for all Excess Output.

**Same Site**

Generating facilities are considered to be located at the same site as the QF for which qualification for the standard rates and standard contract is sought if they are located within a five-mile radius of any generating facilities or equipment providing fuel or motive force associated with the QF for which qualification for the standard rates and standard contract is sought.

**Person(s) or Affiliated Person(s)**

A natural person or persons or any legal entity or entities sharing common ownership, management or acting jointly or in concert with or exercising influence over the policies or actions of another person or entity. Two facilities will not be held to be owned or controlled by the same person(s) or affiliated person(s) solely because they are developed by a single entity. Two facilities will not be held to be owned or controlled by the same person(s) or affiliated person(s) if such common person or persons is a "passive investor" whose ownership interest in the QF is primarily related to utilizing production tax credits, green tag values and MACRS depreciation as the primary ownership benefit and the facilities at issue are independent family-owned or community-based projects. A unit of Oregon local government may also be a "passive investor" in a community-based project if the local governmental unit demonstrates that it will not have an equity ownership interest in or exercise any control over the management of the QF and that its only interest is a share of the cash flow from the QF, which share will not exceed 20%. The 20% cash flow share limit may only be exceeded for good cause shown and only with the prior approval of the Commission.

**Shared Interconnection and Infrastructure**

QFs otherwise meeting the separate ownership test and thereby qualified for entitlement to the standard rates and standard contract will not be disqualified by utilizing an interconnection or other infrastructure not providing motive force or fuel that is shared with other QFs qualifying for the standard rates and standard contract so long as the use of the shared interconnection complies with the interconnecting utility's safety and reliability standards, interconnection contract requirements and Prudent Electrical Practices as that term is defined in the interconnecting utility's approved standard contract.

(continued)

---

**Definitions (continued)****Family Owned**

After excluding the ownership interest of the passive investor whose ownership interests are primarily related to green tag values and tax benefits as the primary ownership benefit, five or fewer individuals own 50 percent or more of the equity of the project entity, or fifteen or fewer individuals own 90 percent or more of the project entity. A "look through" rule applies to closely held entities that hold the project entity, so that equity held by LLCs, trusts, estates, corporations, partnerships or other similar entities is considered held by the equity owners of the look through entity. An individual is a natural person. In counting to five or fifteen, spouses or children of an equity owner of the project owner who also have an equity interest are aggregated and counted as a single individual.

**Community-Based**

A community project (or a community sponsored project) must have a recognized and established organization located within the county of the project or within 50 miles of the project that has a genuine role in helping the project be developed and must have a significant continuing role with or interest in the project after it is completed and placed in service. Many varied and different organizations may qualify under this exception. For example, the community organization could be a church, a school, a water district, an agricultural cooperative, a unit of local government, & local utility, a homeowners' association, a charity, a civic organization, and etc.

After excluding the passive investor whose ownership interests are primarily related to green tag values and tax benefits as the primary ownership benefit, the equity (ownership) interests in a community sponsored project must be owned in substantial percentage (80 percent or more) by the following persons (individuals and entities): (i) the sponsoring organization, or its controlled affiliates; (ii) members of the sponsoring organization (if it is a membership organization) or owners of the sponsorship organization (if it is privately owned); (iii) persons who live in the county in which the project is located or who live a county adjoining the county in which the project is located; or (iv) units of local government, charities, or (v) other established nonprofit organizations active either in the county in which the project is located or active in a county adjoining the county in which the project is located.

**Dispute Resolution**

Upon request, the QF will provide the purchasing utility with documentation verifying the ownership, management and financial structure of the QF in reasonably sufficient detail to allow the utility to make an initial determination of whether or not the QF meets the above-described criteria for entitlement to the standard rates and standard contract.

Any dispute concerning a QF's entitlement to the standard rates and standard contract shall be presented to the Commission for resolution. The QF may file a complaint asking the Commission to adjudicate disputes regarding the formation of the standard contract. The QF may not file such a complaint during any 15-day period in which the utility has the obligation to respond, but must wait until the 15-day period has passed. The utility may respond to the complaint within ten days of service. The Commission will limit its review to the issues identified in the complaint and response, and utilize a process similar to the arbitration process adopted to facilitate the execution of interconnection agreements among telecommunications carriers. See OAR 860, Division 016. The Administrative Law Judge will act as an administrative law judge, not as an arbitrator.

(continued)

**Self Supply Option**

Owner shall elect to sell all Net Output to PacifiCorp and purchase its full electric requirements from PacifiCorp or sell Net Output surplus to its needs at the Facility site to PacifiCorp and purchase partial electric requirements service from PacifiCorp, in accordance with the terms and conditions of the power purchase agreement and the appropriate retail service.

**Pricing Options****1. Standard Fixed Avoided Cost Prices**

Prices are fixed at the time that the contract is signed by both the Qualifying Facility and the Company and will not change during the term of the contract. Standard Fixed Avoided Cost Prices are available for a contract term of up to 15 years and prices under a longer term contract (up to 20 years) will thereafter be under the Firm Market Indexed Avoided Cost Price. The Standard Fixed Avoided Cost pricing option is available to all Qualifying Facilities. The Standard Fixed Avoided Cost Price for Wind Qualifying Facilities will reflect integration costs as set forth on page 5.

**2. Renewable Fixed Avoided Cost Prices**

Prices are fixed at the time that the contract is signed by both the Renewable Qualifying Facility and the Company and will not change during the term of the contract. Renewable Fixed Avoided Cost Prices are available for a contract term of up to 15 years and prices under a longer term contract (up to 20 years) will thereafter be under the Firm Market Indexed Avoided Cost Price. The Renewable Fixed Avoided Cost pricing option is available only to Renewable Qualifying Facilities. A Renewable Qualifying Facility choosing the Renewable Fixed Avoided Cost pricing option: (a) must cede all Green Tags generated by the facility, as defined in the standard contract, to the Company during the Renewable Resource Deficiency Period identified on page 8 including during any period after the first 15 years of a longer term contract (up to 20 years); and (b) will retain ownership of all Environmental Attributes generated by the facility, as defined in the standard contract, during the Renewable Resource Sufficiency Period identified on page 8.

**3. Firm Market Indexed Avoided Cost Prices**

Firm Market Index Avoided Cost Prices are available to Qualifying Facilities that contract to deliver firm power. Monthly On-Peak / Off-Peak prices paid are a blending of Intercontinental Exchange (ICE) Day Ahead Power Price Report at market hubs for On-Peak and Off-Peak prices. The monthly blending matrix is available upon request.

**4. Non-Firm Market Index Avoided Cost Prices**

Non-Firm Market Index Avoided Cost Prices are available to Qualifying Facilities that do not elect to provide firm power. Qualifying Facilities taking this option will have contracts that do not include minimum delivery requirements, default damages for construction delay or, for under delivery or early termination, or default security for these purposes. Monthly On-Peak / Off-Peak prices paid are 93 percent of a blending of ICE Day Ahead Power Price Report at market hubs for on-peak and off-peak firm index prices. The monthly blending matrix is available upon request. The Non-Firm Market Index Avoided Cost pricing option is available to all Qualifying Facilities. The Non-Firm Market Index Avoided Cost Price for Wind Qualifying Facilities will reflect integration costs.

(continued)

**Monthly Payments**

A Qualifying Facility shall select the option of payment at the time of signing the contract under one of the Pricing Options specified above. Once an option is selected the option will remain in effect for the duration of the Facility's contract.

**Renewable or Standard Fixed Avoided Cost Prices**

In accordance with the terms of a contract with a Qualifying Facility, the Company shall pay for all separately metered kilowatt-hours of On-Peak and Off-Peak generation at the renewable or standard fixed prices as provided in this schedule. On-Peak and Off-Peak are defined in the definitions section of this schedule.

**Firm Market Indexed and Non-Firm Market Index Avoided Cost Prices**

In accordance with the terms of a contract with a Qualifying Facility, the Company shall pay for all separately metered kilowatt-hours of On-Peak and Off-Peak generation at the market prices calculated at the time of delivery. On-Peak and Off-Peak are defined in the definitions section of this schedule.

**Avoided Cost Prices**
**Standard Fixed Avoided Cost Prices for Base Load and Wind QF (¢/kWh)**

Deliveries During Calendar Year	Base Load QF (1,3)		Wind QF (2,3)	
	On-Peak Energy Price	Off-Peak Energy Price	On-Peak Energy Price	Off-Peak Energy Price
	(a)	(b)	(c)	(d)
2016	2.34	1.99	2.03	1.67
2017	2.63	2.17	2.31	1.85
2018	2.82	2.30	2.50	1.97
2019	2.94	2.38	2.61	2.05
2020	3.10	2.51	2.76	2.17
2021	3.30	2.71	2.95	2.36
2022	3.60	3.00	3.24	2.64
2023	4.03	3.37	3.66	3.00
2024	4.44	3.73	4.07	3.36
2025	4.66	3.93	4.28	3.55
2026	4.84	4.09	4.45	3.70
2027	5.06	4.27	4.66	3.87
2028	6.28	3.25	5.18	2.84
2029	6.44	3.34	5.31	2.92
2030	6.71	3.55	5.56	3.12
2031	6.88	3.64	5.70	3.20
2032	7.04	3.74	5.84	3.29
2033	7.24	3.86	6.01	3.40
2034	7.43	3.98	6.17	3.51
2035	7.62	4.09	6.33	3.61

(continued)

**Effective for service on and after October 25, 2016**

**AVOIDED COST PURCHASES FROM  
 ELIGIBLE QUALIFYING FACILITIES**
**Avoided Cost Prices (Continued)**
**Standard Fixed Avoided Cost Prices for Fixed and Tracking Solar QF (¢/kWh)**

Deliveries During Calendar Year	Fixed Solar QF (3)		Tracking Solar QF (3)	
	On-Peak Energy Price	Off-Peak Energy Price	On-Peak Energy Price	Off-Peak Energy Price
	(e)	(f)	(g)	(h)
2016	2.34	1.99	2.34	1.99
2017	2.63	2.17	2.63	2.17
2018	2.82	2.30	2.82	2.30
2019	2.94	2.38	2.94	2.38
2020	3.10	2.51	3.10	2.51
2021	3.30	2.71	3.30	2.71
2022	3.60	3.00	3.60	3.00
2023	4.03	3.37	4.03	3.37
2024	4.44	3.73	4.44	3.73
2025	4.66	3.93	4.66	3.93
2026	4.84	4.09	4.84	4.09
2027	5.06	4.27	5.06	4.27
2028	5.84	3.25	5.79	3.25
2029	5.98	3.34	5.93	3.34
2030	6.25	3.55	6.20	3.55
2031	6.40	3.64	6.35	3.64
2032	6.56	3.74	6.51	3.74
2033	6.74	3.86	6.69	3.86
2034	6.93	3.98	6.87	3.98
2035	7.10	4.09	7.05	4.09

- (1) Capacity Contribution to Peak for Avoided Proxy Resource and Base Load Qualifying Facility resource are assumed 100%.
- (2) The standard avoided cost price for wind is reduced by an integration charge of \$3.06/MWh (\$2014). If Wind Qualifying Facility is not in PacifiCorp's balancing authority area, then no reduction is required.
- (3) Standard Resource Sufficiency Period ends December 31, 2027 and Standard Resource Deficiency Period begins January 1, 2028.

(continued)

**Effective for service on and after October 25, 2016**

**Avoided Cost Prices (Continued)**
**Renewable Fixed Avoided Cost Prices for Base Load and Wind QF (¢/kWh)**

Deliveries During Calendar Year	Renewable Base Load QF (1,4)		Wind QF (1,2,3)	
	On-Peak Energy Price (a)	Off-Peak Energy Price (b)	On-Peak Energy Price (c)	Off-Peak Energy Price (d)
2016	2.34	1.99	2.03	1.67
2017	2.63	2.17	2.31	1.85
2018	2.82	2.30	2.50	1.97
2019	2.94	2.38	2.61	2.05
2020	3.10	2.51	2.76	2.17
2021	3.30	2.71	2.95	2.36
2022	3.60	3.00	3.24	2.64
2023	4.03	3.37	3.66	3.00
2024	4.44	3.73	4.07	3.36
2025	4.66	3.93	4.28	3.55
2026	4.84	4.09	4.45	3.70
2027	5.06	4.27	4.66	3.87
2028	10.26	6.60	7.59	6.19
2029	10.47	6.74	7.74	6.32
2030	10.72	6.87	7.93	6.44
2031	10.94	7.03	8.09	6.59
2032	11.18	7.20	8.26	6.76
2033	11.41	7.37	8.43	6.92
2034	11.65	7.55	8.61	7.08
2035	11.87	7.76	8.76	7.28

(continued)

Effective for service on and after October 25, 2016

**Avoided Cost Prices (continued)**
**Renewable Fixed Avoided Cost Prices for Fixed and Tracking Solar QF (¢/kWh)**

Deliveries During Calendar Year	Fixed Solar QF (1,4)		Tracking Solar QF (1,4)	
	On-Peak Energy Price	Off-Peak Energy Price	On-Peak Energy Price	Off-Peak Energy Price
	(e)	(f)	(g)	(h)
2016	2.34	1.99	2.34	1.99
2017	2.63	2.17	2.63	2.17
2018	2.82	2.30	2.82	2.30
2019	2.94	2.38	2.94	2.38
2020	3.10	2.51	3.10	2.51
2021	3.30	2.71	3.30	2.71
2022	3.60	3.00	3.60	3.00
2023	4.03	3.37	4.03	3.37
2024	4.44	3.73	4.44	3.73
2025	4.66	3.93	4.66	3.93
2026	4.84	4.09	4.84	4.09
2027	5.06	4.27	5.06	4.27
2028	8.55	6.60	8.78	6.60
2029	8.72	6.74	8.96	6.74
2030	8.93	6.87	9.17	6.87
2031	9.11	7.03	9.36	7.03
2032	9.30	7.20	9.56	7.20
2033	9.49	7.37	9.76	7.37
2034	9.70	7.55	9.97	7.55
2035	9.87	7.76	10.15	7.76

- (1) For the purpose of determining: (i) when the Renewable Qualifying Facility is entitled to renewable avoided cost prices; and (ii) the ownership of Environmental Attributes and the transfer of Green Tags to PacifiCorp, the Renewable Resource Sufficiency Period ends December 31, 2027, and the Renewable Resource Deficiency Period begins January 1, 2028.
- (2) During the Renewable Resource Deficiency Period, the renewable avoided cost price for a Wind Qualifying Facility will be adjusted by adding the difference between the avoided integration costs and the Qualifying Facility's integration costs. If the Wind Qualifying Facility is in PacifiCorp's Balancing Authority Area (BAA), the adjustment is zero (integration costs cancel each other out). If the Wind Qualifying Facility is not in PacifiCorp's BAA, the renewable avoided cost price will be increased by avoided integration charge of \$3.06/MWh (\$2014).
- (3) During Renewable Resource Sufficiency Period, the renewable avoided cost price for a Wind Qualifying Facility is reduced by an integration charge of \$3.06/MWh (\$2014) for Wind Qualifying Facilities located in PacifiCorp's BAA (in-system). If a Wind Qualifying Facility is not in PacifiCorp's BAA, the renewable avoided cost price will be increased by avoided integration charge of \$3.06/MWh (\$2014).
- (4) During the Renewable Resource Deficiency Period, the renewable avoided cost price for Base Load, Fixed Solar and Tracking Solar is increased by an integration charge of \$3.06/MWh (\$2014).

(continued)

**Effective for service on and after October 25, 2016**

**Qualifying Facilities Contracting Procedure**

Interconnection and power purchase agreements are handled by different functions within the Company. Interconnection agreements (both transmission and distribution level voltages) are handled by the Company's transmission function (PacifiCorp Transmission Services) while power purchase agreements are handled by the Company's merchant function (PacifiCorp Commercial and Trading).

It is recommended that the owner initiate its request for interconnection 18 months ahead of the anticipated in-service date to allow time for studies, negotiation of agreements, engineering, procurement, and construction of the required interconnection facilities. Early application for interconnection will help ensure that necessary interconnection arrangements proceed in a timely manner on a parallel track with negotiation of the power purchase agreement.

**1. Eligible Qualifying Facilities**

**APPLICATION:** To owners of eligible existing or proposed QFs with a design capacity less than or equal to 10,000 kW for Base Load and Wind QF resources and less than or equal to 3,000 kW for Solar QF resources who desire to make sales to the Company in the state of Oregon. Such owners will be required to enter into a written power purchase agreement with the Company pursuant to the procedures set forth below.

**I. Process for Completing a Power Purchase Agreement****A. Communications**

Unless otherwise directed by the Company, all communications to the Company regarding QF power purchase agreements should be directed in writing as follows:

PacifiCorp  
Manager-QF Contracts  
825 NE Multnomah St, Suite 600  
Portland, Oregon 97232

The Company will respond to all such communications in a timely manner. If the Company is unable to respond on the basis of incomplete or missing information from the QF owner, the Company shall indicate what additional information is required. Thereafter, the Company will respond in a timely manner following receipt of all required information.

(continued)



**B. Procedures**

1. The Company's approved generic or standard form power purchase agreements may be obtained from the Company's website at [www.pacificorp.com](http://www.pacificorp.com), or if the owner is unable to obtain it from the website, the Company will send a copy within seven days of a written request.
2. In order to obtain a project specific draft power purchase agreement the owner must provide in writing to the Company, general project information required for the completion of a power purchase agreement, including, but not limited to:
  - (a) demonstration of ability to obtain QF status;
  - (b) design capacity (MW), station service requirements, and net amount of power to be delivered to the Company's electric system;
  - (c) generation technology and other related technology applicable to the site;
  - (d) proposed site location;
  - (e) schedule of monthly power deliveries;
  - (f) calculation or determination of minimum and maximum annual deliveries;
  - (g) motive force or fuel plan;
  - (h) proposed on-line date and other significant dates required to complete the milestones;
  - (i) proposed contract term and pricing provisions as defined in this Schedule (i.e., standard fixed price, renewable fixed price);
  - (j) status of interconnection or transmission arrangements;
  - (k) point of delivery or interconnection;
3. The Company shall provide a draft power purchase agreement when all information described in Paragraph 2 above has been received in writing from the QF owner. Within 15 business days following receipt of all information required in Paragraph 2, the Company will provide the owner with a draft power purchase agreement including current standard avoided cost prices and/or other optional pricing mechanisms as approved by the Public Utility Commission of Oregon in this Standard Avoided Cost Rate Schedule.
4. If the owner desires to proceed with the power purchase agreement after reviewing the Company's draft power purchase agreement, it may request in writing that the Company prepare a final draft power purchase agreement. In connection with such request, the owner must provide the Company with any additional or clarified project information that the Company reasonably determines to be necessary for the preparation of a final draft power purchase agreement. Within 15 business days following receipt of all information requested by the Company in this paragraph 4, the Company will provide the owner with a final draft power purchase agreement.

(continued)

**B. Procedures (continued)**

5. After reviewing the final draft power purchase agreement, the owner may either prepare another set of written comments and proposals or approve the final draft power purchase agreement. If the owner prepares written comments and proposals the Company will respond in 15 business days to those comments and proposals.
  
6. When both parties are in full agreement as to all terms and conditions of the draft power purchase agreement, the Company will prepare and forward to the owner within 15 business days, a final executable version of the agreement. Following the Company's execution a completely executed copy will be returned to the owner. Prices and other terms and conditions in the power purchase agreement will not be final and binding until the power purchase agreement has been executed by both parties.

**II. Process for Negotiating Interconnection Agreements**

[NOTE: Section II applies only to QFs connecting directly to PacifiCorp's electrical system. An off-system QF should contact its local utility or transmission provider to determine the interconnection requirements and wheeling arrangement necessary to move the power to PacifiCorp's system.]

In addition to negotiating a power purchase agreement, QFs intending to make sales to the Company are also required to enter into an interconnection agreement that governs the physical interconnection of the project to the Company's transmission or distribution system. The Company's obligation to make purchases from a QF is conditioned upon the QF completing all necessary interconnection arrangements. It is recommended that the owner initiate its request for interconnection 18 months ahead of the anticipated in-service date to help ensure that necessary interconnection arrangements proceed in a timely manner on a parallel track with negotiation of the power purchase agreement.

Because of functional separation requirements mandated by the Federal Energy Regulatory Commission, interconnection and power purchase agreements are handled by different functions within the Company. Interconnection agreements (both transmission and distribution level voltages) are handled by the Company's transmission function (including but not limited to PacifiCorp Transmission Services) while power purchase agreements are handled by the Company's merchant function (including but not limited to PacifiCorp's Commercial and Trading Group).

(continued)

**II. Process for Negotiating Interconnection Agreements (continued)****A. Communications**

Initial communications regarding interconnection agreements should be directed to the Company in writing as follows:

PacifiCorp  
Director – Transmission Services  
825 NE Multnomah St, Suite 1600  
Portland, Oregon 97232

Based on the project size and other characteristics, the Company will direct the QF owner to the appropriate individual within the Company's transmission function who will be responsible for negotiating the interconnection agreement with the QF owner. Thereafter, the QF owner should direct all communications regarding interconnection agreements to the designated individual, with a copy of any written communications to the address set forth above.

**B. Procedures**

Generally, the interconnection process involves (1) initiating a request for interconnection, (2) undertaking studies to determine the system impacts associated with the interconnection and the design, cost, and schedules for constructing any necessary interconnection facilities, and (3) executing an interconnection agreement to address facility construction, testing, acceptance, ownership, operation and maintenance issues. Consistent with PURPA and Oregon Public Utility Commission regulations, the owner is responsible for all interconnection costs assessed by the Company on a nondiscriminatory basis. For interconnections impacting the Company's Transmission and Distribution System, the Company will process the interconnection application through PacifiCorp Transmission Services.