

Law Office of
Richard A. Finnigan

Richard A. Finnigan
(360) 956-7001

2405 Evergreen Park Drive SW
Suite B-1
Olympia, Washington 98502
Fax (360) 753-6862

Kathy McCrary, Paralegal
(360) 753-7012
Lisa Skelley, Legal Asst.
(360) 753-4679

March 23, 2005

VIA ELECTRONIC MAIL AND U.S. MAIL

Filing Center
Oregon Public Utility Commission
PO Box 2148
Salem, OR 97308-2148

Re: UM 1140 – Trunk Configurations

Dear Sir/Madam:

During the course of the hearing in UM 1140, Qwest witness Linse was asked to accept certain matters concerning the trunk configurations between Beaver Creek Cooperative Telephone Company (BCT) and Qwest Corporation as a matter "subject to check." ALJ Petrillo asked that the parties be able to confirm what the witness was asked on a "subject to check" basis.

Attached are two trunk diagrams that show the trunking arrangements: (1) for local/EAS trunking and (2) for trunking to the access tandem. On the local/EAS trunk diagram, it shows that there are two trunks for 911 purposes that are routed on a diverse basis. It shows that there are 360 traditional EAS trunks running between the BCT switch and the Qwest Portland local/EAS tandem. It also shows that there are an additional 48 LIS trunks running between BCT's switch and the Qwest local/EAS tandem. The local/EAS tandem is noted as PTLDOR1350T. The trunk diagram also shows 96 trunks between the BCT switch and the Qwest Oregon City switch. Finally, the diagram shows 46 trunks running between the BCT switch and Qwest's Milwaukee switch.

In the diagram depicting trunking to the access tandem, there are 9 trunks labeled TSPS, which are operator service trunks. There are 96 trunks between the BCT switch and the Portland access tandem (PTLDOR13C9T). In addition, there are 24 more LIS trunks from BCT's switch to that same

OPUC Filing Center
March 23, 2005
Page 2 of 2

tandem.

The trunking diagrams have been reviewed by Qwest. Qwest agrees that the diagrams are accurate depictions of the trunking relationships between the two companies. Qwest suggested some changes to the descriptions contained in this letter. Most of the changes have been incorporated. The few that were not were discussed with Mr. Duarte earlier this week and he authorized the submission of this letter, subject to hearing from his client by the close of business on March 22, 2005. No further word has been received from Qwest.

Qwest also suggested that the two diagrams have a slight change in title. Qwest suggested that the first diagram be labeled "BCT-Qwest EAS & LIS Local Trunk Inter-connection Diagram" and the second diagram be labeled "BCT TG# 334/Qwest TG# AP087435: 48 Trunks (LIS-Local)." Given that the diagrams are PDF documents and given the passage of time and the relatively small difference in labels, the change has not been made. BCT does not believe the difference in labels is pertinent and has no objection to either label.

BCT suggests that the trunk diagrams be assigned Exhibit Nos. BCT/13 and BCT/14, respectively.

Sincerely,

s/Richard A. Finnigan

RICHARD A. FINNIGAN

RAF/ljs
Enclosures

cc: Tom Linstrom
Parties of Record

BCT-Qwest EAS & LIS-EAS Trunk Inter-Connection Diagram:

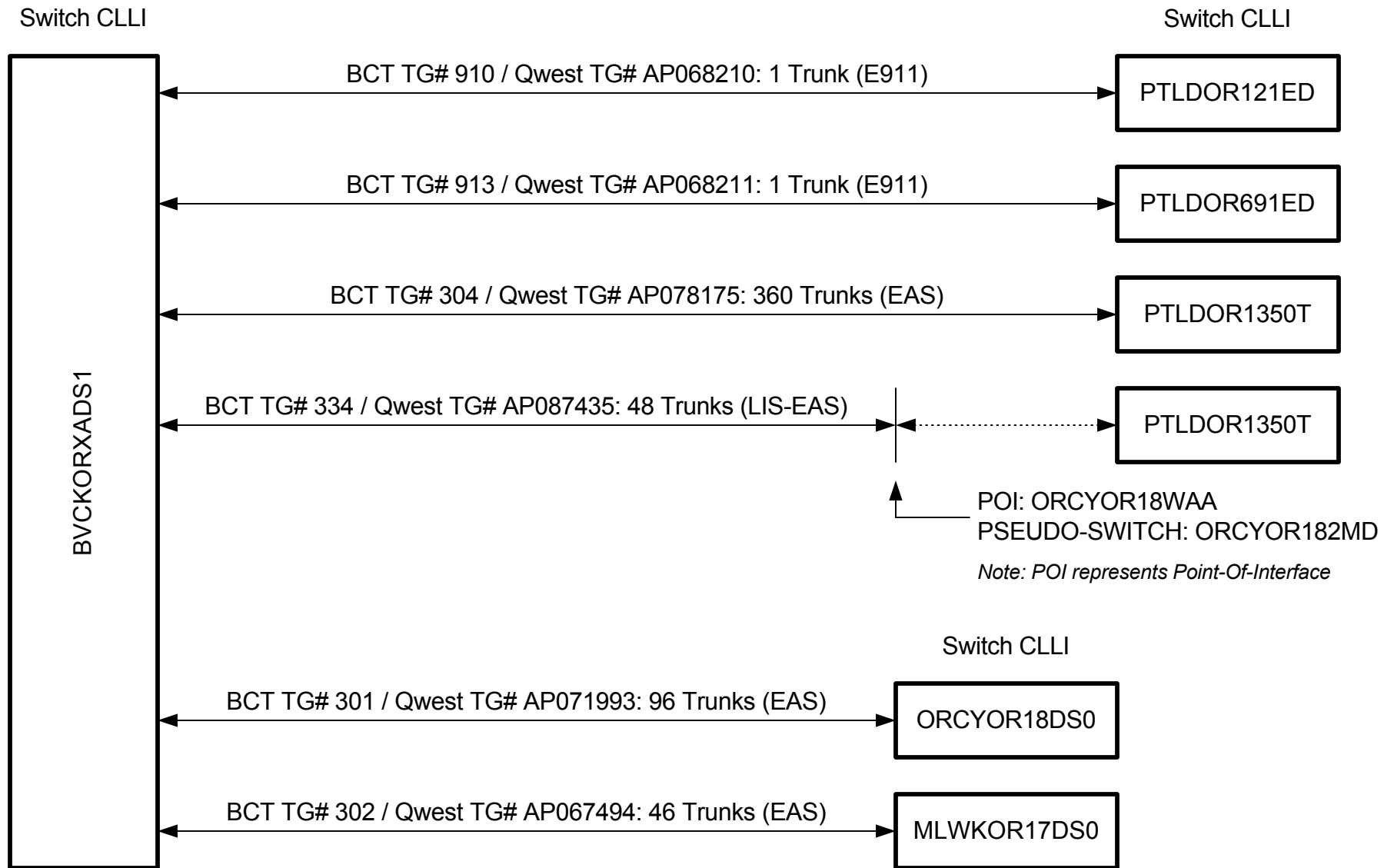

BCT-Qwest Toll & LIS-Toll Trunk Inter-Connection Diagram:

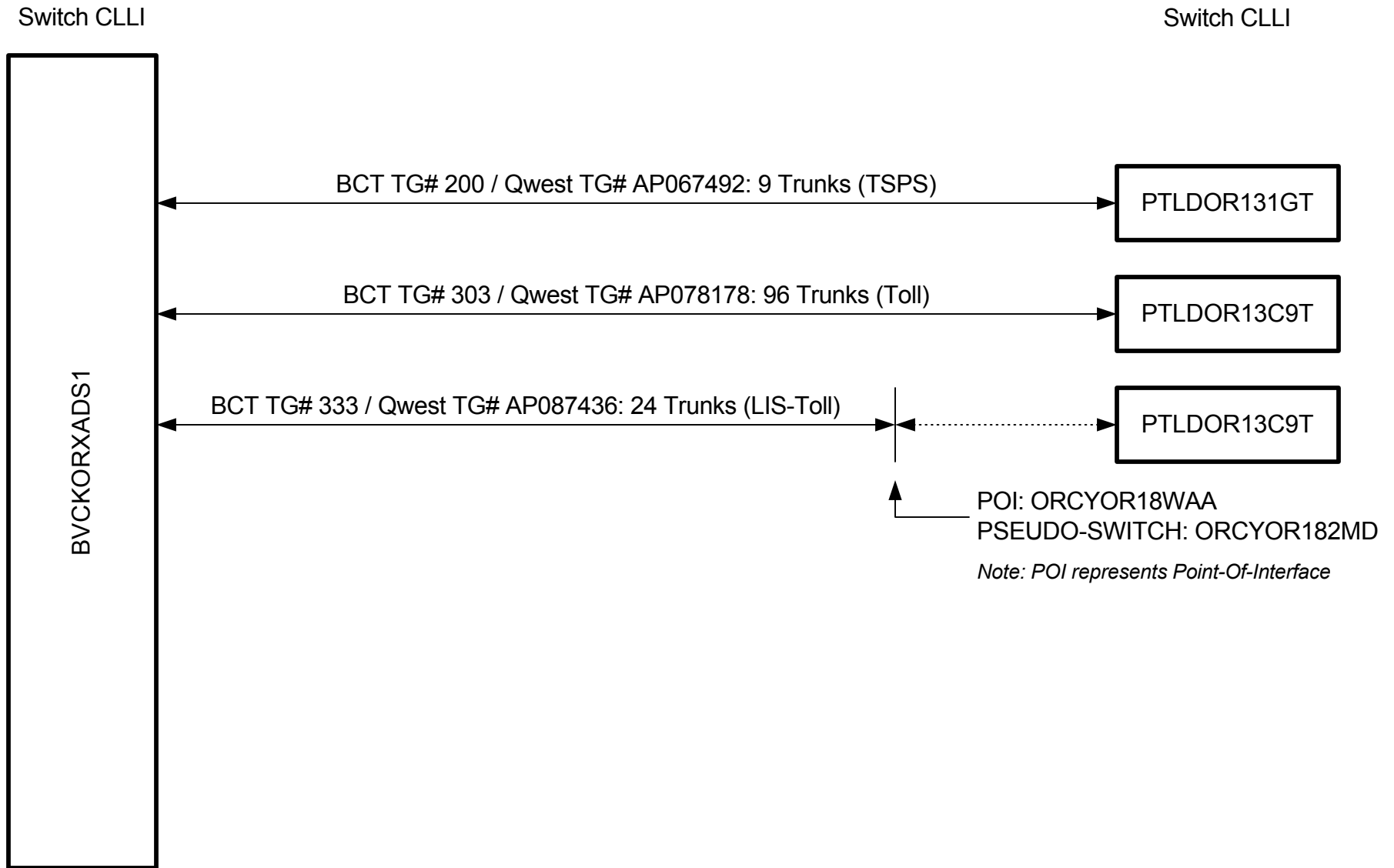

CERTIFICATE OF SERVICE
UM 1140

I hereby certify that I have served the attached letter dated March 23, 2005 to the Oregon Public Utility Commission and two Trunk Diagrams upon all parties of record in this proceeding by U.S. Mail and electronic mail pursuant to OAR 860-013-0070 to the following parties or attorneys of parties:

ALEX DUARTE
QWEST CORPORATION
421 SW OAK STREET, ROOM 810
PORTLAND, OR 97204
alex.duarte@qwest.com

MARK P TRINCHERO
DAVIS WRIGHT TREMAINE LLP
1300 SW FIFTH AVE STE 2300
PORTLAND OR 97201-5682
marktrincher@dw.com

JAY NUSBAUM
PERKINS COIE LLP
1120 NW COUCH ST 10TH FLOOR
PORTLAND, OR 97209-4128
nusbj@perkinscoie.com

JENNIFER NIEGEL
DUNCAN TIGER & NIEGEL PC
PO BOX 248
STAYTON OR 97383-0248
jennifer@staytonlaw.com

I further certify that I have sent the attached letter dated March 23, 2005 to the Oregon Public Utility Commission and two Trunk Diagrams by e-mail and U.S. mail to the following:

FILING CENTER
OREGON PUBLIC UTILITY COMMISSION
PO BOX 2148
SALEM, OR 97308-2148
PUC.FilingCenter@state.or.us

Dated this 23rd day of March, 2005.

s/Richard A. Finnigan
Richard A. Finnigan, OSB No. 96535
Attorney for Beaver Creek
Cooperative Telephone Company