



e-FILING REPORT COVER SHEET

COMPANY NAME: Portland General Electric Company

DOES REPORT CONTAIN CONFIDENTIAL INFORMATION? No Yes If yes, submit a redacted public version (or a cover letter) by email. Submit the confidential information as directed in OAR 860-001-0070 or the terms of an applicable protective order.

Select report type: RE (Electric) RG (Gas) RW (Water) RT (Telecommunications) RO (Other, for example, industry safety information)

Did you previously file a similar report? No Yes, report docket number: RE-143

Report is required by: OAR 860-029-0030 Statute Order

Note: A one-time submission required by an order is a compliance filing and not a report (file compliance in the applicable docket)

Other (For example, federal regulations, or requested by Staff)

Is this report associated with a specific docket/case? No Yes, docket number: RE-143

List Key Words for this report. We use these to improve search results.

Community Solar Program, Purchase Agreement

Send the completed Cover Sheet and the Report in an email addressed to PUC.FilingCenter@state.or.us

Send confidential information, voluminous reports, or energy utility Results of Operations Reports to PUC Filing Center, PO Box 1088, Salem, OR 97308-1088 or by delivery service to 201 High Street SE Suite 100, Salem, OR 97301.



Portland General Electric
121 SW Salmon Street · Portland, Ore. 97204

April 12, 2021

Public Utility Commission of Oregon
Attn: Filing Center
201 High Street, S.E.
P.O. Box 1088
Salem, OR 97308-1088

**RE: RE 143 – Portland General Electric Company Informational Filing of
Community Solar Program (CSP) Purchase Agreement**

Pursuant to Oregon Administrative Rule (OAR) 860-029-0030(7), Portland General Electric Company (PGE) submits for filing in OPUC Docket No. RE-143:

Mt Hope Solar, Executed Community Solar Program (CSP)
Purchase Agreement

For this and several additional agreements, PGE did not meet the requirements of OAR 860-029-0030(7) to provide the Commission a true copy or summary within 30 days of the execution of the purchase agreement. PGE has fixed the process and will provide executed agreements on time going forward.

Should you have any questions or comments regarding this filing, please contact Mary Widman at (503) 464-8223. Please direct all formal correspondence and requests to the following email address pge.opuc.filings@pge.com

Sincerely,

\s\ Robert Macfarlane

Robert Macfarlane
Manager, Pricing & Tariffs

Enclosure

COMMUNITY SOLAR PROGRAM PURCHASE AGREEMENT

THIS COMMUNITY SOLAR PROGRAM PURCHASE AGREEMENT (the “Agreement”) entered into this third day of December, 2020 (the “Effective Date”), is between Mt Hope Solar, LLC, an Oregon Limited Liability Company (“Project Manager”), and Portland General Electric Company, an Oregon corporation acting in its regulated utility capacity (“PGE”). Project Manager and PGE are referred to individually in this Agreement as a “Party” and collectively as the “Parties.”

RECITALS

A. Project Manager intends to operate a solar photovoltaic facility for the generation of electric power, including interconnection facilities, located in Clackamas County Latitude: 45.128 Longitude -122.614 with a facility capacity rating of 2,502 kilowatts (kW) as further described in Exhibit A and Exhibit B (“Facility”); and

B. Project Manager intends to commence delivery of Net Output under this Agreement, for the purpose of start-up testing, on January 8, 2020; and

C. Project Manager intends to operate the Facility as a Community Solar Program Project, commencing commercial operations on February 1, 2021 (“Scheduled Commercial Operation Date”).

D. Project Manager estimates that the average annual Net Output to be delivered by the Facility to PGE is 4,813,000 kilowatt-hours (kWh); and

E. This Agreement is a Community Solar Program Purchase Agreement under the Oregon Community Solar Program implemented by the Oregon Public Utility Commission pursuant to ORS 757.386(2).

AGREEMENT

NOW, THEREFORE, the Parties mutually agree as follows:

SECTION 1: DEFINITIONS

When used in this Agreement, the following terms shall have the following meanings:

Agreement means this Community Solar Program Purchase Agreement.

As-Available Rate is the rate at which PGE will purchase a Project’s Unsubscribed Energy and is set forth in PGE’s Schedule 201.

Average Annual Generation has the meaning stated in Section 5.6.

Certified Project is a Community Solar Program Project that has been certified by the Oregon Public Utility Commission under OAR 860-088-0050 and in accordance with the Program Implementation Manual.

Commercial Operation Date means the date that the Facility is deemed by PGE to be fully operational and reliable, which requires, among other things, that all of the following events have occurred:

1. Seller provides evidence that the Facility is a Certified Project.
2. PGE has received a certificate addressed to PGE from a Licensed Professional Engineer stating (a) the facility capacity rating of the Facility at the anticipated Commercial Operation Date; (b) that the Facility is able to generate electric power reliably in amounts required by this Agreement and in accordance with all other terms and conditions of this Agreement; (c) the Facility has completed start-up testing and commissioning; and (d) in accordance with the Generation Interconnection Agreement, all required interconnection facilities have been constructed, all required interconnection tests have been completed, and the Facility is physically interconnected with PGE's electric system;
3. PGE has received a certificate addressed to PGE from an officer of Project Manager stating that Project Manager has obtained all Required Project Documents and, if requested by PGE in writing, has provided copies of any or all such requested Required Project Documents; and
4. PGE has received an executed copy of Exhibit E—Project Manager's Authorization to Release Generation Data to PGE.

Community Solar Program is the program established for the procurement of electricity from community solar projects pursuant to ORS 757.386(2), the Commission's implementing regulations, and the Program Implementation Manual.

Community Solar Program Project is one or more solar photovoltaic energy systems used to generate electric energy on behalf of Community Solar Program owners and subscribers and for which owners and subscribers receive credit on their electric bills.

Conditional DNR Notice has the meaning provided in Section 3.1.

Contract Interest Rate means the lesser of (a) the highest rate permitted under applicable law or (b) 200 basis points per annum plus the rate per annum equal to the publicly announced prime rate or reference rate for commercial loans to large businesses in effect from time to time quoted by Citibank, N.A. as its "prime rate." If a Citibank, N.A. prime rate is not available, the applicable prime rate shall be the announced prime rate or reference rate for commercial loans in effect from time to time quoted by a bank with \$10 billion or more in assets in New York City, N.Y., selected by the Party to whom interest is being paid.

Contract Year means a twelve (12) month period commencing at 00:00 hours Pacific Prevailing Time (PPT) on January 1 and ending on 24:00 hours PPT on December 31; provided, however, that the first Contract Year shall commence on the Commercial Operation Date and end on the next succeeding December 31, and the last Contract Year shall end on the date of termination or expiration of this Agreement.

Effective Date means the date stated in the first sentence of this Agreement.

Energy Delivery Schedule has the meaning provided in Section 5.7.

Facility has the meaning provided in the Recitals.

Generation Interconnection Agreement means the generation interconnection agreement between Project Manager and Transmission Provider, providing for the construction, operation, and maintenance of the interconnection facilities required to accommodate deliveries of the Facility's Net Output.

Licensed Professional Engineer means a person acceptable to PGE in its reasonable judgment who is licensed to practice engineering in the state of Oregon and is not an employee of Project Manager. Such Licensed Professional Engineer shall be licensed in an appropriate engineering discipline for the required certification being made.

Losses are the loss of electric energy occurring as a result of the transformation and transmission of electric energy from the Facility to the Point of Delivery.

Net Output means all energy produced by the Facility, less Station Use and Losses, if any. For purposes of calculating payment under this Agreement, Net Output shall be the amount of energy flowing through the Point of Delivery.

Non-QF Period has the meaning provided in Section 3.4(b).

Participant means a customer of PGE that is either a subscriber or owner of the Facility.

Point of Delivery is the location where PGE's and Facility's electrical facilities are interconnected.

Program Administrator means the third-party directed by the Oregon Public Utility Commission to administer the Community Solar Program.

Program Implementation Manual means the manual of requirements applicable to the Project Manager, PGE and Participants for the Community Solar Program adopted by the Oregon Public Utility Commission. In the event there are revisions to the Program Implementation Manual during the term of this Agreement, such revisions will only apply to performance by Project Manager and PGE after the effective date of such revisions.

Project Manager is the entity having responsibility for managing the operation of the Facility and for maintaining contact with PGE, as stated in the first sentence of this Agreement.

Prudent Electrical Practices means those practices, methods, standards and acts engaged in or approved by a significant portion of the electric power industry in the Western Electric Coordinating Council that at the relevant time period, in the exercise of reasonable judgment in light of the facts known or that should reasonably have been known at the time a decision was made, would have been expected to accomplish the desired result in a manner consistent with good business practices, reliability, economy, safety and expedition, and which practices, methods, standards and acts reflect due regard for operation and maintenance standards recommended by applicable equipment suppliers and manufacturers, operational limits, and all applicable law. Prudent Electrical Practices are not intended to be limited to the optimum practice, method, standard or act to the exclusion of all others, but rather to those practices, methods and

acts generally acceptable or approved by a significant portion of the electric power generation industry in the relevant region, during the relevant period, as described in the immediately preceding sentence.

PURPA means the Public Utility Regulatory Policies Act of 1978.

Qualifying Facility is a solar photovoltaic facility that meets the PURPA criteria for qualification set forth in Subpart B of Part 292, Subchapter K, Chapter I, Title 18, of the Code of Federal Regulations.

Renewable Energy Credits means green tags, green certificates, renewable energy credits (RECs) and tradable renewable certificates, as those terms are commonly used in the regional electric utility industry, directly associated with the production of energy from the Facility.

Required Project Documents means all licenses, permits, authorizations, and agreements, including a Generation Interconnection Agreement and Qualifying Facility certification or self-certification, necessary for construction, operation, and maintenance of the Facility consistent with the terms of this Agreement, including without limitation those listed in Exhibit C.

Scheduled Commercial Operation Date has the meaning provided in the Recitals.

Station Use is electric energy used to operate the Facility that is auxiliary to or directly related to the generation of electricity and which, but for the contemporaneous generation of electricity, would not be consumed by the Facility.

Subscribed Energy means that portion of the Net Output delivered to PGE after COD and for which the Project Manager has obtained a Participant. PGE must credit the Participant's electric bills consistent with the Community Solar Program for any Subscribed Energy.

Transmission Provider means PGE, acting in its transmission provider capacity.

Unsubscribed Energy means that portion of the Net Output delivered to PGE that is not Subscribed Energy. PGE will purchase Unsubscribed Energy at the As-Available Rate consistent with the Community Solar Program.

SECTION 2: TERM

2.1 Term. Except as otherwise provided herein, this Agreement shall terminate at midnight (Pacific prevailing time) on the date that is the twentieth (20th) anniversary of the Commercial Operation Date.

SECTION 3: DELIVERY OF POWER AND COMPENSATION

3.1 Designation of Network Resource. Within five (5) business days following the Effective Date, PGE will submit an application to the Transmission Provider requesting designation of the Facility as a network resource, thereby authorizing network transmission service under PGE's Network Integration Transmission Service Agreement with the Transmission Provider. PGE will request an effective date for commencement of network transmission service for the Facility that is ninety (90) days prior to the Scheduled Commercial Operation Date. PGE will inform Project Manager of Transmission

Provider's response to the application described above in this paragraph within five (5) days of PGE's receipt of such response from the Transmission Provider. If PGE is notified in writing by the Transmission Provider that designation of the Facility as a network resource requires the construction of transmission system network upgrades or otherwise requires potential re-dispatch of other network resources of PGE (a "Conditional DNR Notice"), PGE and Project Manager will promptly meet to determine how such conditions to the Facility's network resource designation will be addressed in this Agreement. If, within sixty (60) days following the date of PGE's receipt of the Conditional DNR Notice, PGE and Project Manager are unable to reach agreement regarding how to designate the Facility as a network resource in light of the Conditional DNR Notice, PGE will submit the matter to the Commission for a determination on whether, as a result of the Conditional DNR Notice, this Agreement should be terminated or amended. PGE will submit such filing to the Commission within ninety (90) days following the date of PGE's receipt of the Conditional DNR Notice. In the event of such a filing to the Commission under this Section, the Parties' obligations under this Agreement will be suspended until such time that the Commission issues a final decision. In the event of a Conditional DNR Notice, Project Manager will have the right to terminate this Agreement upon written notice to PGE and such termination by Project Manager will not be an event of default and no damages will be owed by Project Manager to PGE related to the termination of this Agreement except to the extent PGE has incurred costs at Project Manager's request in furtherance of addressing the matters covered under this Section.

3.2 Delivery and Purchase of Net Output. Subject to Section 3.1 above and unless otherwise provided in this Agreement, commencing on the Commercial Operation Date, Project Manager will transmit to PGE all Net Output and PGE will accept all Net Output delivered to the Point of Delivery. PGE will accept Net Output delivered to the Point of Delivery as early as ninety (90) days prior to the Scheduled Commercial Operation Date. If Seller desires to begin transmitting Net Output to PGE at a date earlier than ninety (90) days prior to the Scheduled Commercial Operation Date, PGE will only be obligated to purchase such Net Output if PGE is able to modify its network resource designation for the Facility such that the output could be delivered using network transmission service as described in Section 3.1 above at no additional cost or other economic impact to PGE.

3.3 Curtailment. PGE shall have no obligation to purchase Net Output from the Facility to the extent the interconnection between the Facility and PGE's electric system is disconnected, suspended or interrupted, in whole or in part, pursuant to the Generation Interconnection Agreement, or to the extent generation curtailment is required as a result of Seller's non-compliance with the Generation Interconnection Agreement.

3.4 Compensation. PGE will pay the Program Administrator for Unsubscribed Energy and the Participants for Subscribed Energy on a monthly basis as provided in the Community Solar Program.

(a) For the portion of the monthly Net Output that is Subscribed Energy, PGE will credit the electric bills of Participants to account for their proportionate share of the Net Output in accordance with the requirements of the Community Solar Program and data provided by the Program Administrator.

(b) For the portion of the monthly Net Output that is Unsubscribed Energy that is delivered to PGE by Project Manager from the Facility at the Point of Delivery, PGE will pay the Program Administrator the As-Available Rate consistent with the Community Solar Program; provided, however, that PGE has no obligation to pay the Program Administrator for Unsubscribed Energy

delivered to PGE for any period that Program Manager is in violation of Section 5.2 (the “Non-QF Period”). The Non-QF Period shall conclude upon PGE’s receipt from Program Manager of satisfactory evidence that the Facility has cured the breach of Section 5.2.

SECTION 4: RENEWABLE ENERGY CREDITS

4.1 No Claim to Renewable Energy Certificates. PGE waives any claim to ownership of any Renewable Energy Certificates that are issued by the Western Renewable Energy Generation Information System associated with the Facility’s Net Output.

SECTION 5: OPERATION AND CONTROL

5.1 Community Solar Program Compliance. Project Manager shall maintain the Facility as a Community Solar Program Project at all times during the term of this Agreement

5.2 Qualifying Facility. Project Manager shall maintain the Facility as a Qualifying Facility at all times during the term of this Agreement.

5.3 As-Built Supplement. Upon completion of initial construction of the Facility, and upon any subsequent material modification of the Facility, Project Manager shall provide PGE an as-built supplement to specify the actual Facility as built.

5.4 Facility Operation. Project Manager must operate and maintain the Facility in a safe manner in accordance with the Generation Interconnection Agreement, Prudent Electrical Practices and in accordance with the requirements of all applicable federal, state and local laws and the National Electric Safety Code as such laws and code may be amended from time to time. PGE has no obligation to purchase Net Output from the Project Manager to the extent the interconnection between the Facility and PGE’s electric system is disconnected, suspended or interrupted, in whole or in part, pursuant to the Generation Interconnection Agreement.

5.5 Facility Inspection. Project Manager is solely responsible for the operation and maintenance of the Facility. PGE has the right, upon reasonable prior notice to Project Manager, to inspect the Facility to confirm that the Project Manager is operating the Facility in accordance with the provisions of this Agreement, provided that PGE is not, by reason of its decision to inspect or not to inspect the Facility, or by any action or inaction taken with respect to any such inspection, assuming any responsibility for any liability or occurrence arising from the operation and maintenance by Project Manager of the Facility.

5.6 Average Generation and Energy Delivery Schedules. Project Manager estimates that the Facility will generate, on average, 4,382,070 kWh per Contract Year (“Average Annual Generation”). Project Manager may, upon at least six (6) months prior written notice, modify the Average Annual Generation every other Contract Year. Project Manager’s initial monthly schedule of expected Net Output from the Facility is attached as Exhibit D (the “Energy Delivery Schedule”). Project Manager

must update and provide to PGE a revised Energy Delivery Schedule within thirty (30) days following the end of each Contract Year.

5.7 Scheduled Outages. Project Manager may cease operation of the entire Facility or individual units for maintenance or other purposes. Project Manager must exercise reasonable efforts to notify PGE of planned outages at least ninety (90) days prior to the planned outage. Additionally, Project Manager must use commercially reasonable efforts to not plan outages during the months of December and July.

5.8 Unplanned Outages. In the event of an unscheduled outage or curtailment exceeding twenty-five (25) percent of the facility capacity rating expected to last more than 48 hours, Project Manager must promptly notify PGE of the unscheduled outage or curtailment, the time when such occurred or will occur, and the anticipated duration.

5.9 Adjustments to Scheduled Commercial Operation Date. Project Manager must promptly notify PGE in writing of any adjustments (earlier or later) to the Scheduled Commercial Operation Date. Project Manager must also inform PGE in writing no later than ten (10) business days prior to the Scheduled Commercial Operation Date of the anticipated Commercial Operation Date, provided such notice to PGE may not be provided earlier than twenty (20) business days prior to the anticipated Commercial Operation Date.

SECTION 6: METERING AND COMMUNICATIONS

6.1 Metering and Communications.

(a) Metering equipment will be designed, furnished, installed, owned, inspected, tested, maintained and replaced pursuant to the terms of the Generation Interconnection Agreement and OAR 860-082-0070(2). Unless the Facility is exempt from providing or paying for data acquisition or telemetry equipment pursuant to OAR 860-082-0070(2), Project Manager will bear all costs relating to all metering and communication equipment installed to accommodate the Facility.

(b) Metering shall be performed at the location and in a manner consistent with this Agreement, the Generation Interconnection Agreement, and the requirements of the Community Solar Program. All quantities of energy purchased under this Agreement will be adjusted to account for electrical losses, if any, between the point of metering and the Point of Delivery, so that the purchased amount reflects the net amount of energy flowing into PGE's system at the Point of Delivery.

(c) If any of the inspections or tests of the metering equipment discloses an error exceeding two percent (2%), either fast or slow, proper correction, based upon the inaccuracy found, will be made of previous readings for the actual period during which the metering equipment rendered inaccurate measurements if that period can be ascertained. If the actual period cannot be ascertained, the proper correction will be made to the measurements taken during the time the metering equipment was in service since the last test in which the metering equipment was found to be accurate, but not exceeding three (3) months, in the amount the metering equipment shall have been shown to be in error by such test. Any correction in billings or payments resulting from a correction in the meter records will be made in the next payment rendered following the repair of the meter.

SECTION 7: INSURANCE

7.1 Certificates. To the extent the Facility has a facility capacity rating exceeding 200 kW, prior to connection of the Facility to PGE's electric system, Project Manager shall secure and continuously carry insurance in compliance with the requirements of this Section. Project Manager shall provide PGE insurance certificate(s) confirming Project Manager's compliance with the insurance requirements hereunder. If requested by PGE, a copy of each insurance policy, certified as a true copy by an authorized representative of the issuing insurance company, shall be furnished to PGE.

7.2 Required Policies and Coverages. Without limiting any liabilities or any other obligations of Project Manager under this Agreement, Project Manager shall secure and continuously carry with an insurance company or companies rated not lower than "B+" by the A.M. Best Company commercial general liability insurance to include premises and operations, contractual liability, with a minimum single limit of \$1,000,000 each occurrence to protect against and from loss by reason of injury to persons or damage to property based upon and arising out of the activity under this Agreement.

7.3 The commercial general liability policy required herein shall include (a) provisions or endorsements naming PGE, its board of directors, officers and employees as additional insureds, and (b) cross liability coverage so that the insurance applies separately to each insured against whom claim is made or suit is brought, even in instances where one insured claims against or sues another insured. In addition, unless prohibited by applicable law, all required insurance policies shall contain provisions that the insurer will have no right of recovery or subrogation against PGE.

7.4 The commercial general liability policy required herein shall include provisions that such insurance is primary insurance with respect to the interests of PGE and that any other insurance maintained by PGE is excess and not contributory insurance with the insurance required hereunder, and provisions that such policies shall not be canceled or their limits of liability reduced without (a) ten (10) days prior written notice to PGE if canceled for nonpayment of premium, or (b) thirty (30) days prior written notice to PGE if canceled for any other reason.

7.5 Commercial general liability coverage written on a "claims-made" basis, if any, shall be specifically identified on the certificate, and Project Manager shall be maintained by Project Manager for a minimum period of five (5) years after the completion of this Agreement and for such other length of time necessary to cover liabilities arising out of the activities under this Agreement.

SECTION 8: COMPUTATIONS

8.1 Net Output Data. No later than the second business day of each month, PGE will transfer to the Program Administrator the data related to the amount of Net Output delivered to PGE from the Facility for the month, measured in kWh.

SECTION 9: COMPENSATION

9.1 Payment for Unsubscribed Energy. No later than the 20th day of the month or ten (10) business days after receiving kWh data from Program Administrator regarding the prior month's Subscribed Energy amount and Unsubscribed Energy amount, whichever occurs later, PGE will send to Program Administrator payment for Project Manager deliveries of Unsubscribed Energy to PGE, together

with computations supporting such payment. PGE may offset any such payment to reflect amounts owing from Project Manager to PGE pursuant to this Agreement, the Generation Interconnection Agreement, or any other agreement between the Parties.

9.2 Corrections. PGE may adjust any payment made under this Agreement for Unsubscribed Energy or Subscribed Energy up to eighteen (18) months following the date of original payment.

9.3 Interest. Any amounts owing after the due date thereof will bear interest at the Contract Interest Rate.

9.4 Payment for Subscribed Energy. PGE will credit the electric bills of Participants for their proportionate shares of Subscribed Energy in accordance with the Program Implementation Manual and data provided by Program Administrator.

9.5 Offset. PGE may offset any payment due to the Project Manager by amounts owing from the Project Manager pursuant to this Agreement and any other agreement between the Parties related to the Facility.

SECTION 10: SUCCESSORS AND ASSIGNS

Neither Party may assign this Agreement without the consent of the other Party and the Oregon Public Utility Commission, which shall not be unreasonably withheld. This Agreement and all of the terms shall be binding upon and inure to the benefit of the respective successors and assigns of the Parties.

SECTION 11: NOTICES

All notices except as otherwise provided in this Agreement shall be in writing addressed to the addresses set forth below and shall be considered if delivered in person or when deposited in the U.S. Mail, postage prepared by certified or registered mail and return receipt requested.

If to PGE:
Portland General Electric Company
Attn: Contracts Administration 3WTC-0306
121 SW Salmon Street
Portland, OR 97204

If to Project Manager:
Mt Hope Solar, LLC
1327 SE Tacoma St, #235
Portland, OR 97202

SECTION 12: INDEMNIFICATION AND LIABILITY

12.1 Project Manager's Indemnity. Project Manager agrees to defend, indemnify and hold harmless PGE, its directors, officers, employees, agents, and representatives against and from any and all claims resulting from, or arising out of or in any way connected with (i) Project Manager's performance hereunder, including the delivery of energy to and at the Point of Delivery; (ii) Project Manager's development, construction, ownership, operation, maintenance, or decommissioning of the Facility; (iii) the violation of any law, rule, order or regulation by Project Manager or any of its affiliates, or their respective employees, contractors or agents in connection with this Agreement; (iv) Project Manager's failure to perform any of Project Manager's obligations under this Agreement or the Required Facility Documents; (v) Project Manager's breach of any representation or warranty set forth in this Agreement;

or (vi) Project Manager's negligence or willful misconduct in connection with this Agreement, except to the extent such claim is caused by breach of this Agreement or by the negligence or willful misconduct of PGE, its directors, officers, employees, agents or representatives.

12.2 PGE's Indemnity. PGE agrees to defend, indemnify and hold harmless Project Manager, its directors, officers, agents, and representatives against and from any and all claims resulting from, or arising out of or in any way connected with (i) PGE's receipt of Net Output under this Agreement after its delivery at the Point of Delivery; (ii) the violation of any law, rule, order or regulation by PGE, or their respective employees, or agents in connection with this Agreement; (iii) PGE's failure to perform any of PGE's obligations under this Agreement; (iv) PGE's breach of any representation or warranty set forth in this Agreement; or (v) PGE's negligence or willful misconduct in connection with this Agreement, except to the extent such claim is caused by Project Manager's breach of this Agreement or by the negligence or willful misconduct of Project Manager, its directors, officers, employees, agents or representatives.

12.3 No Dedication. Nothing in this Agreement shall be construed to create any duty to, any standard of care with reference to, or any liability to any person not a Party to this Agreement. No undertaking by one Party to the other under any provision of this Agreement shall constitute the dedication of that Party's system or any portion thereof to the other Party or to the public, nor affect the status of PGE as an independent public utility corporation or Project Manager as an independent person.

12.4 Disclaimer of Consequential Damages. **NEITHER PARTY SHALL BE LIABLE TO THE OTHER FOR SPECIAL, PUNITIVE, INDIRECT OR CONSEQUENTIAL DAMAGES UNDER OR IN RESPECT OF THIS AGREEMENT, WHETHER ARISING FROM CONTRACT, TORT (INCLUDING NEGLIGENCE), STRICT LIABILITY OR OTHERWISE.**

SECTION 13: TERMINATION

13.1 Termination. In the event Project Manager remains in breach of any provision of this Agreement for a period exceeding thirty (30) days following PGE's notice of breach, PGE may notify Program Administrator in writing to request that the Agreement be terminated for the event of default. The Program Administrator will evaluate such notification consistent with the Community Solar Program, and such Agreement will be terminated only upon order of the Program Administrator or the Commission.

SECTION 14: GENERAL PROVISIONS

14.1 Relationship of the Parties. Nothing contained in this Agreement shall ever be construed to create an association, trust, partnership or joint venture or to impose a trust or partnership duty, obligation or liability between the Parties. If Project Manager includes two or more parties, each such Party shall be jointly and severally liable for Project Manager's obligations under this Agreement.

14.2 No Third Party Beneficiaries. This Agreement shall not impart any rights enforceable by any third party (other than a permitted successor or assignee bound to this Agreement), it being the intent of the Parties that this Agreement shall not be construed as a third party beneficiary contract.

14.3 Governing Law. This Agreement shall be interpreted and enforced in accordance with the laws of the state of Oregon, excluding any choice of law rules which may direct the application of the laws of another jurisdiction. This Agreement is subject to the jurisdiction of those governmental agencies and courts having control over either Party or this Agreement. Each Party hereby acknowledges that this Agreement and any dispute that arises under this Agreement is subject to the jurisdiction of the Oregon Public Utility Commission. If a dispute related to this Agreement arises between the Parties, the Parties' representatives shall first attempt to resolve the dispute informally through negotiation and consultation. If the Parties are unable to resolve their differences through such negotiation and consultation, any complaint, claim or action to resolve such dispute may be brought in a court or governmental agency with jurisdiction over the dispute.

14.4 Severability. If any of the terms of this Agreement are finally held or determined to be invalid, illegal or void as being contrary to any applicable law or public policy, all other terms of this Agreement shall remain in effect. If any terms are finally held or determined to be invalid, illegal or void, the Parties shall enter into negotiations, and seek guidance from the Program Administrator and Oregon Public Utility Commission as necessary, concerning the terms affected by such decision for the purpose of achieving conformity with requirements of any applicable law, the intent of the Parties, and the Community Solar Program.

14.5 Effect of PURPA Repeal. The repeal of PURPA shall not result in the early termination of this Agreement unless such termination is mandated by state or federal law.

14.6 Waiver. Any waiver at any time by either Party of its rights with respect to a default under this Agreement or with respect to any other matters arising in connection with this Agreement must be in writing, and such waiver shall not be deemed a waiver with respect to any subsequent default or other matter.

14.7 Survival. Notwithstanding termination of this Agreement, PGE and Project Manager shall continue to be bound by the provisions of this Agreement which by their terms or by their nature shall survive such completion or termination.

14.8 Entire Agreement; Amendments; Order of Precedence. This Agreement supersedes all prior agreements, proposals, representations, negotiations, discussions or letters, whether oral or in writing, regarding PGE's purchase of energy from the Facility. No amendment or modification of this Agreement shall be effective unless it is in writing and signed by both Parties. If there is a conflict between the terms of this Agreement and the Community Solar Program the Community Solar Program shall apply and prevail.

14.9 Project Release. By executing this Agreement, Project Manager releases PGE from any third party claims related to the Facility, known or unknown, which may have arisen prior to the Effective Date.

14.10 Rights and Remedies Cumulative. Except as expressly set forth in this Agreement, the rights and remedies of the Parties provided in this Agreement and otherwise available at law or in equity are cumulative, such that the exercise of one or more rights or remedies shall not constitute a waiver of any other rights or remedies.

14.11 Approval by the Oregon Public Utility Commission. The Parties acknowledge that PGE has made changes to this Agreement in the definitions of Subscribed Energy, Unsubscribed Energy, and Section 3.4. PGE will seek approval from the Oregon Public Utility Commission for these changes. PGE and Project Manager agree to amend this Agreement to the extent necessary to conform with the requirements of any Oregon Public Utility Commission order approving or modifying PGE's request.

[remainder of page intentionally left blank]

IN WITNESS WHEREOF, the Parties hereto have caused this Agreement to be executed in their respective names as of the Effective Date.

Portland General Electric Company

By: Larry Bekkedahl
Larry Bekkedahl (Jan 26, 2021 17:42 PST)
Name: Larry Bekkedahl
Title: VP Grid Architecture, Integration & System Ops
Date: Jan 26, 2021

BCG
BCG

TM
TM

JRG
JRG

JJ
JJ

Project Manager

By: Stephen Gates
Stephen Gates (Jan 24, 2021 17:14 PST)
Name: Stephen Gates
Title: Manager
Date: Jan 24, 2021

EXHIBIT A
DESCRIPTION OF PROJECT MANAGER'S FACILITY

[Project Manager to Complete]

Location of the Facility: The Facility is to be constructed in the vicinity of Latitude: 45.128 Longitude -122.614 in Clackamas County, Oregon. The location is more particularly described as follows:

*SITUATED IN THE NORTH HALF OF SECTION 19, TOWNSHIP 5 SOUTH, RANGE 2 EAST,
W.M., CITY OF MOLALLA, COUNTY OF CLACKAMAS, STATE OF OREGON*

Beginning at the Northeast corner of Section 19; thence South 63°13'04" West a distance of 1,517.27 feet to an existing 6 foot tall chain link fence corner, said point also being the True Point of Beginning; thence following an existing 6 foot tall chain link fence the following courses and distances; North 89°59'19" West, a distance of 1,301.68 feet to a fence corner; South 00°03'45" East a distance of 394.88 feet to a fence corner; North 89°57'50" East a distance of 901.96 feet to an angle point in the fence; North 84°07'16" East a distance of 145.92 feet to an angle point in the fence; North 89°25'14" East a distance of 201.20 feet to a fence corner; North 15°17'46" East a distance of 199.66 feet to an angle point in the fence; North 00°05'19" East a distance of 184.49 feet to the True Point of Beginning; containing 502,927 square feet more or less.

Description of the Facility: Project Manager's Facility consists of CSUN375-72BMH-DG-Bifacial panels rated at 3251.25 kWDC and an expected annual degradation rate of 1% manufactured by CSUN Solar (or equivalent), 38 inverters manufactured by Canadian Solar, and a Single axis tracker racking system.

More specifically, each generator at the Facility is described as:

Manufacturer's Nameplate Data: 3251.25 KW DC, 2502 KW AC

Solar Panels

Manufacturer: CSUN Solar or equivalent
Model: CSUN375-72BMH-DG-Bifacial
Power rating (Watts DC @ STC): 375W
Number of Modules: 8670
Number of Modules per string: 17

Inverters

Manufacturer: Canadian Solar or equivalent
Model: CSI-66KTL-GS, CSI-60KTL-GS

Inverter Rating (AC, kW): 66 kW, 60 kW
Number of Inverters: 38
Inverter Efficiency at Full Power Rating (%): 98%
Inverter Capacity for Site (AC, kW): 2502 kW
Operation Voltage (Volts): 579 - 850V
Maximum System Design Voltage: 889V
Number of Phases: 3

Mounting

Groundmount or rooftop? Groundmount
Fixed tilt or Single-axis Tracking? Single axis tracker
Proposed Module orientation: Single axis tracker East/West
Tilt Angle (Degrees): +/-50 deg (adjustable to +/- 60 deg)
Azimuth (Degrees): 90°W/270E: East/West
Pitch (Row Spacing) (Feet): Average = 27.79 ft (E-W). Varies throughout the site.
Row Width (Feet): 13ft 4inches
Row Length (Feet): Varies throughout site.
Max/min rotation (if tracking) (Degrees): +50/-50
Ground Coverage Ratio: 48.2%

PV Array Characteristics

Rated Output (kW): 3251 kW DC / 2502kW AC
Rated Output (kVA): 2502 kVA

Transformation

Number of Step-up transformers: 1
Size of Step-up Transformers (kVA): 2800 kVA
Low Side voltage of Step-up transformer (volts): 480
High Side voltage of Step up transformer (volts): 12470

Total land required: 11.55 acres

Power factor requirements

Rated Power Factor (PF) or reactive load (kVAR): PF= 1
Leading: 0.8(+/-0.8 adjustable) Lagging: 0.8(+/-0.8 adjustable)

Project Manager's Estimate of Facility Annual Output Under Ideal (Maximum) or Worst (Minimum) Conditions

Maximum kW Output (“Maximum Facility Delivery Rate”): 2476 kW AC
Maximum kVA Output: 2476 kVA
Minimum kW Output: -0.3 kW
Estimated kW Output: 2476 kW AC
Maximum Generator Interconnection Agreement Delivery Rate: N/A kW [instantaneous]

Nameplate Capacity Rating: 2502 kW AC at 25° C

Estimated station service for lighting and other auxiliary energy requirements is estimated to be approximately 12265.9 kWh annually.

PV Panel output degradation factor: 1% per year.

EXHIBIT B

POINT OF DELIVERY / PROJECT MANAGER'S INTERCONNECTION FACILITIES

[Instructions to Project Manager:

1. Include description of point of metering, and Point of Delivery
 - a. Both are located inside medium voltage switchgear on a pad entering the gate to the site.

2. Provide interconnection single line drawing of Facility including any transmission facilities on Project Manager's side of the Point of Delivery.]

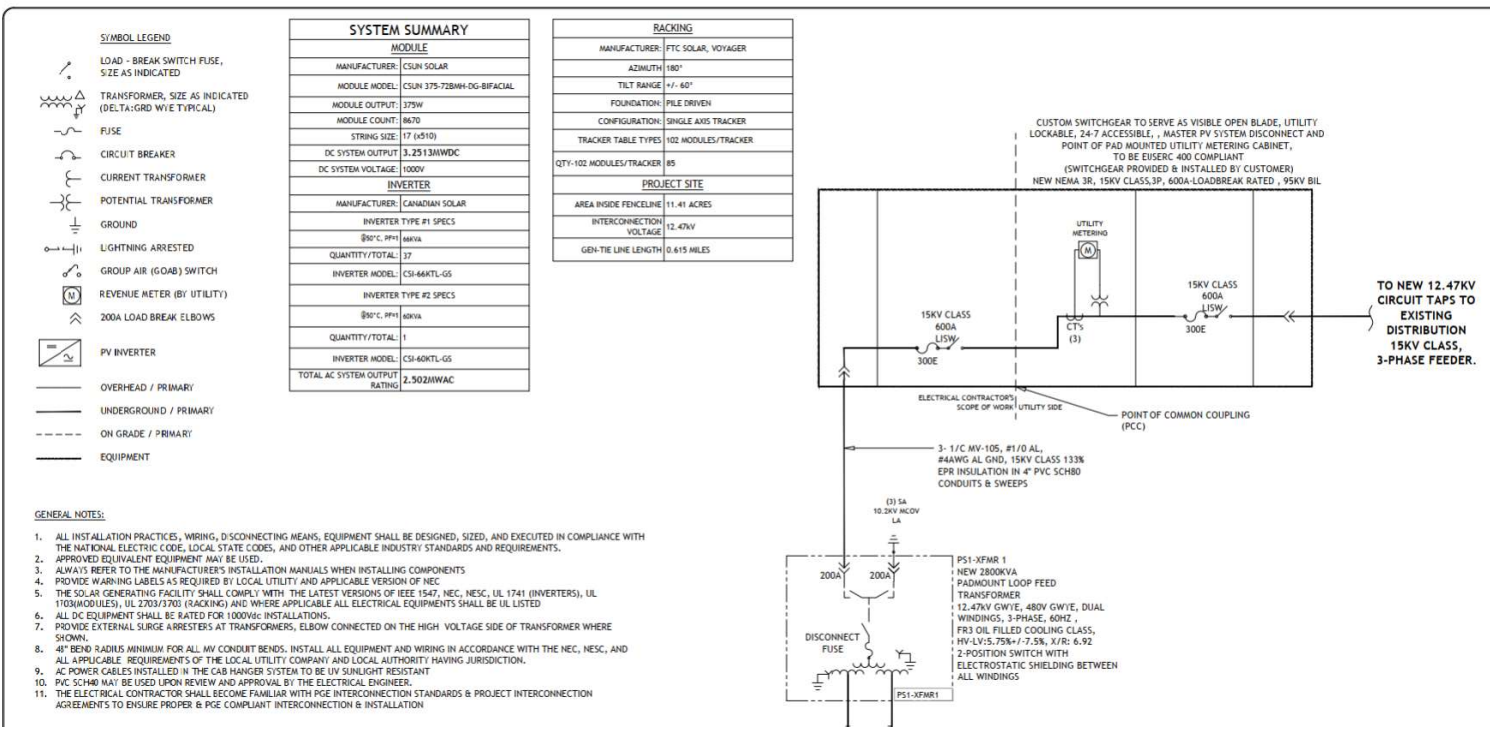

GENERAL NOTES:

1. ALL INSTALLATION PRACTICES, WIRING, DISCONNECTING MEANS, EQUIPMENT SHALL BE DESIGNED, SIZED, AND EXECUTED IN COMPLIANCE WITH THE NATIONAL ELECTRIC CODE, LOCAL STATE CODES, AND OTHER APPLICABLE INDUSTRY STANDARDS AND REQUIREMENTS.
2. APPROVED EQUIVALENT EQUIPMENT MAY BE USED.
3. ALWAYS REFER TO THE MANUFACTURER'S INSTALLATION MANUALS WHEN INSTALLING COMPONENTS
4. PROVIDE WARNING LABELS AS REQUIRED BY LOCAL UTILITY AND APPLICABLE VERSION OF NEC
5. THE SOLAR GENERATING FACILITY SHALL COMPLY WITH THE LATEST VERSIONS OF IEEE 1547, NEC, NESC, UL 1741 (INVERTERS), ILL 1703(MODULES), UL 2703/3703 (RACKING) AND WHERE APPLICABLE ALL ELECTRICAL EQUIPMENTS SHALL BE UL LISTED
6. ALL DC EQUIPMENT SHALL BE RATED FOR 1000Vdc INSTALLATIONS.
7. PROVIDE EXTERNAL SURGE ARRESTERS AT TRANSFORMERS, ELBOW CONNECTED ON THE HIGH VOLTAGE SIDE OF TRANSFORMER WHERE SHOWN.
8. 48" BEND RADIUS MINIMUM FOR ALL MV CONDUIT BENDS. INSTALL ALL EQUIPMENT AND WIRING IN ACCORDANCE WITH THE NEC, NESC, AND ALL APPLICABLE REQUIREMENTS OF THE LOCAL UTILITY COMPANY AND LOCAL AUTHORITY HAVING JURISDICTION.
9. AC POWER CABLES INSTALLED IN THE CAB HANGER SYSTEM TO BE UV SUNLIGHT RESISTANT
10. PVC SCH80 MAY BE USED UPON REVIEW AND APPROVAL BY THE ELECTRICAL ENGINEER.
11. THE ELECTRICAL CONTRACTOR SHALL BECOME FAMILIAR WITH PGE INTERCONNECTION STANDARDS & PROJECT INTERCONNECTION AGREEMENTS TO ENSURE PROPER & PGE COMPLIANT INTERCONNECTION & INSTALLATION.

B-2

EXHIBIT C

REQUIRED FACILITY DOCUMENTS

[Reference QF certification]

FEDERAL ENERGY REGULATORY COMMISSION
WASHINGTON, DC

OMB Control # 1902-0075
Expiration 06/30/2019

Form 556

Certification of Qualifying Facility (QF) Status for a Small Power
Production or Cogeneration Facility

General

Questions about completing this form should be sent to Form556@ferc.gov. Information about the Commission's QF program, answers to frequently asked questions about QF requirements or completing this form, and contact information for QF program staff are available at the Commission's QF website, www.ferc.gov/QF. The Commission's QF website also provides links to the Commission's QF regulations (18 C.F.R. § 131.80 and Part 292), as well as other statutes and orders pertaining to the Commission's QF program.

Who Must File

Any applicant seeking QF status or recertification of QF status for a generating facility with a net power production capacity (as determined in lines 7a through 7g below) greater than 1000 kW must file a self-certification or an application for Commission certification of QF status, which includes a properly completed Form 556. Any applicant seeking QF status for a generating facility with a net power production capacity 1000 kW or less is exempt from the certification requirement, and is therefore not required to complete or file a Form 556. See 18 C.F.R. § 292.203.

How to Complete the Form 556

This form is intended to be completed by responding to the items in the order they are presented, according to the instructions given. If you need to back-track, you may need to clear certain responses before you will be allowed to change other responses made previously in the form. If you experience problems, click on the nearest help button (?) for assistance, or contact Commission staff at Form556@ferc.gov.

Certain lines in this form will be automatically calculated based on responses to previous lines, with the relevant formulas shown. You must respond to all of the previous lines within a section before the results of an automatically calculated field will be displayed. If you disagree with the results of any automatic calculation on this form, contact Commission staff at Form556@ferc.gov to discuss the discrepancy before filing.

You must complete all lines in this form unless instructed otherwise. Do not alter this form or save this form in a different format. Incomplete or altered forms, or forms saved in formats other than PDF, will be rejected.

How to File a Completed Form 556

Applicants are required to file their Form 556 electronically through the Commission's eFiling website (see instructions on page 2). By filing electronically, you will reduce your filing burden, save paper resources, save postage or courier charges, help keep Commission expenses to a minimum, and receive a much faster confirmation (via an email containing the docket number assigned to your facility) that the Commission has received your filing.

If you are simultaneously filing both a waiver request and a Form 556 as part of an application for Commission certification, see the "Waiver Requests" section on page 3 for more information on how to file.

Paperwork Reduction Act Notice

This form is approved by the Office of Management and Budget. Compliance with the information requirements established by the FERC Form No. 556 is required to obtain or maintain status as a QF. See 18 C.F.R. § 131.80 and Part 292. An agency may not conduct or sponsor, and a person is not required to respond to, a collection of information unless it displays a currently valid OMB control number. The estimated burden for completing the FERC Form No. 556, including gathering and reporting information, is as follows: 3 hours for self-certification of a small power production facility, 8 hours for self-certifications of a cogeneration facility, 6 hours for an application for Commission certification of a small power production facility, and 50 hours for an application for Commission certification of a cogeneration facility. Send comments regarding this burden estimate or any aspect of this collection of information, including suggestions for reducing this burden, to the following: Information Clearance Officer, Office of the Executive Director (ED-32), Federal Energy Regulatory Commission, 888 First Street N.E., Washington, DC 20426 (DataClearance@ferc.gov); and Desk Officer for FERC, Office of Information and Regulatory Affairs, Office of Management and Budget, Washington, DC 20503 (oir_submission@omb.eop.gov). Include the Control No. 1902-0075 in any correspondence.

Electronic Filing (eFiling)

To electronically file your Form 556, visit the Commission's QF website at www.ferc.gov/QF and click the eFiling link.

If you are eFiling your first document, you will need to register with your name, email address, mailing address, and phone number. If you are registering on behalf of an employer, then you will also need to provide the employer name, alternate contact name, alternate contact phone number and alternate contact email.

Once you are registered, log in to eFiling with your registered email address and the password that you created at registration. Follow the instructions. When prompted, select one of the following QF-related filing types, as appropriate, from the Electric or General filing category.

Filing category	Filing Type as listed in eFiling	Description
Electric	(Fee) Application for Commission Cert. as Cogeneration QF	Use to submit an application for Commission certification or Commission recertification of a cogeneration facility as a QF.
	(Fee) Application for Commission Cert. as Small Power QF	Use to submit an application for Commission certification or Commission recertification of a small power production facility as a QF.
	Self-Certification Notice (QF, EG, FC)	Use to submit a notice of self-certification of your facility (cogeneration or small power production) as a QF.
	Self-Recertification of Qualifying Facility (QF)	Use to submit a notice of self-recertification of your facility (cogeneration or small power production) as a QF.
	Supplemental Information or Request	Use to correct or supplement a Form 556 that was submitted with errors or omissions, or for which Commission staff has requested additional information. Do not use this filing type to report new changes to a facility or its ownership; rather, use a self-recertification or Commission recertification to report such changes.
General	(Fee) Petition for Declaratory Order (not under FPA Part 1)	Use to submit a petition for declaratory order granting a waiver of Commission QF regulations pursuant to 18 C.F.R. §§ 292.204(a) (3) and/or 292.205(c). A Form 556 is not required for a petition for declaratory order unless Commission recertification is being requested as part of the petition.

You will be prompted to submit your filing fee, if applicable, during the electronic submission process. Filing fees can be paid via electronic bank account debit or credit card.

During the eFiling process, you will be prompted to select your file(s) for upload from your computer.

Filing Fee

No filing fee is required if you are submitting a self-certification or self-recertification of your facility as a QF pursuant to 18 C.F.R. § 292.207(a).

A filing fee is required if you are filing either of the following:

- (1) an application for Commission certification or recertification of your facility as a QF pursuant to 18 C.F.R. § 292.207(b), or
- (2) a petition for declaratory order granting waiver pursuant to 18 C.F.R. §§ 292.204(a)(3) and/or 292.205(c).

The current fees for applications for Commission certifications and petitions for declaratory order can be found by visiting the Commission's QF website at www.ferc.gov/QF and clicking the Fee Schedule link.

You will be prompted to submit your filing fee, if applicable, during the electronic filing process described on page 2.

Required Notice to Utilities and State Regulatory Authorities

Pursuant to 18 C.F.R. § 292.207(a)(ii), you must provide a copy of your self-certification or request for Commission certification to the utilities with which the facility will interconnect and/or transact, as well as to the State regulatory authorities of the states in which your facility and those utilities reside. Links to information about the regulatory authorities in various states can be found by visiting the Commission's QF website at www.ferc.gov/QF and clicking the Notice Requirements link.

What to Expect From the Commission After You File

An applicant filing a Form 556 electronically will receive an email message acknowledging receipt of the filing and showing the docket number assigned to the filing. Such email is typically sent within one business day, but may be delayed pending confirmation by the Secretary of the Commission of the contents of the filing.

An applicant submitting a self-certification of QF status should expect to receive no documents from the Commission, other than the electronic acknowledgement of receipt described above. Consistent with its name, a self-certification is a certification *by the applicant itself* that the facility meets the relevant requirements for QF status, and does not involve a determination by the Commission as to the status of the facility. An acknowledgement of receipt of a self-certification, in particular, does not represent a determination by the Commission with regard to the QF status of the facility. An applicant self-certifying may, however, receive a rejection, revocation or deficiency letter if its application is found, during periodic compliance reviews, not to comply with the relevant requirements.

An applicant submitting a request for Commission certification will receive an order either granting or denying certification of QF status, or a letter requesting additional information or rejecting the application. Pursuant to 18 C.F.R. § 292.207(b)(3), the Commission must act on an application for Commission certification within 90 days of the later of the filing date of the application or the filing date of a supplement, amendment or other change to the application.

Waiver Requests

18 C.F.R. § 292.204(a)(3) allows an applicant to request a waiver to modify the method of calculation pursuant to 18 C.F.R. § 292.204(a)(2) to determine if two facilities are considered to be located at the same site, for good cause. 18 C.F.R. § 292.205(c) allows an applicant to request waiver of the requirements of 18 C.F.R. §§ 292.205(a) and (b) for operating and efficiency upon a showing that the facility will produce significant energy savings. A request for waiver of these requirements must be submitted as a petition for declaratory order, with the appropriate filing fee for a petition for declaratory order. Applicants requesting Commission recertification as part of a request for waiver of one of these requirements should electronically submit their completed Form 556 along with their petition for declaratory order, rather than filing their Form 556 as a separate request for Commission recertification. Only the filing fee for the petition for declaratory order must be paid to cover both the waiver request and the request for recertification *if such requests are made simultaneously*.

18 C.F.R. § 292.203(d)(2) allows an applicant to request a waiver of the Form 556 filing requirements, for good cause. Applicants filing a petition for declaratory order requesting a waiver under 18 C.F.R. § 292.203(d)(2) do not need to complete or submit a Form 556 with their petition.

Geographic Coordinates

If a street address does not exist for your facility, then line 3c of the Form 556 requires you to report your facility's geographic coordinates (latitude and longitude). Geographic coordinates may be obtained from several different sources. You can find links to online services that show latitude and longitude coordinates on online maps by visiting the Commission's QF webpage at www.ferc.gov/QF and clicking the Geographic Coordinates link. You may also be able to obtain your geographic coordinates from a GPS device, Google Earth (available free at <http://earth.google.com>), a property survey, various engineering or construction drawings, a property deed, or a municipal or county map showing property lines.

Filing Privileged Data or Critical Energy Infrastructure Information in a Form 556

The Commission's regulations provide procedures for applicants to either (1) request that any information submitted with a Form 556 be given privileged treatment because the information is exempt from the mandatory public disclosure requirements of the Freedom of Information Act, 5 U.S.C. § 552, and should be withheld from public disclosure; or (2) identify any documents containing critical energy infrastructure information (CEII) as defined in 18 C.F.R. § 388.113 that should not be made public.

If you are seeking privileged treatment or CEII status for any data in your Form 556, then you must follow the procedures in 18 C.F.R. § 388.112. See www.ferc.gov/help/filing-guide/file-ceii.asp for more information.

Among other things (see 18 C.F.R. § 388.112 for other requirements), applicants seeking privileged treatment or CEII status for data submitted in a Form 556 must prepare and file both (1) a complete version of the Form 556 (containing the privileged and/or CEII data), and (2) a public version of the Form 556 (with the privileged and/or CEII data redacted). Applicants preparing and filing these different versions of their Form 556 must indicate below the security designation of this version of their document. If you are *not* seeking privileged treatment or CEII status for any of your Form 556 data, then you should not respond to any of the items on this page.

<p>Non-Public: Applicant is seeking privileged treatment and/or CEII status for data contained in the Form 556 lines <input type="checkbox"/> indicated below. This non-public version of the applicant's Form 556 contains all data, including the data that is redacted in the (separate) public version of the applicant's Form 556.</p>
<p>Public (redacted): Applicant is seeking privileged treatment and/or CEII status for data contained in the Form 556 lines <input type="checkbox"/> indicated below. This public version of the applicants's Form 556 contains all data <u>except</u> for data from the lines indicated below, which has been redacted.</p>
<p>Privileged: Indicate below which lines of your form contain data for which you are seeking privileged treatment</p> <div style="background-color: #e6f2ff; height: 60px; width: 100%;"></div>
<p>Critical Energy Infrastructure Information (CEII): Indicate below which lines of your form contain data for which you are seeking CEII status</p> <div style="background-color: #e6f2ff; height: 60px; width: 100%;"></div>





The eFiling process described on page 2 will allow you to identify which versions of the electronic documents you submit are public, privileged and/or CEII. The filenames for such documents should begin with "Public", "Priv", or "CEII", as applicable, to clearly indicate the security designation of the file. Both versions of the Form 556 should be unaltered PDF copies of the Form 556, as available for download from www.ferc.gov/QF. To redact data from the public copy of the submittal, simply omit the relevant data from the Form. For numerical fields, leave the redacted fields blank. For text fields, complete as much of the field as possible, and replace the redacted portions of the field with the word "REDACTED" in brackets. Be sure to identify above all fields which contain data for which you are seeking non-public status.

The Commission is not responsible for detecting or correcting filer errors, including those errors related to security designation. If your documents contain sensitive information, make sure they are filed using the proper security designation.

FEDERAL ENERGY REGULATORY COMMISSION
WASHINGTON, DC

OMB Control # 1902-0075
Expiration 06/30/2019

Form 556 Certification of Qualifying Facility (QF) Status for a Small Power
Production or Cogeneration Facility

Application Information	1a Full name of applicant (legal entity on whose behalf qualifying facility status is sought for this facility) Mt Hope Solar, LLC		
	1b Applicant street address 1327 SE Tacoma St #235		
	1c City Portland		1d State/province OR
	1e Postal code 97202	1f Country (if not United States)	1g Telephone number 8082688090
	1h Has the instant facility ever previously been certified as a QF? Yes <input checked="" type="checkbox"/> No <input type="checkbox"/>		
	1i If yes, provide the docket number of the last known QF filing pertaining to this facility. <input type="text" value="18 - 345 - 000"/> 		
	1j Under which certification process is the applicant making this filing? <input checked="" type="checkbox"/> Notice of self-certification (see note below) <input type="checkbox"/> Application for Commission certification (requires filing fee; see "Filing Fee" section on page 3) Note: a notice of self-certification is a notice by the applicant itself that its facility complies with the requirements for QF status. A notice of self-certification does not establish a proceeding, and the Commission does not review a notice of self-certification to verify compliance. See the "What to Expect From the Commission After You File" section on page 3 for more information.		
	1k What type(s) of QF status is the applicant seeking for its facility? (check all that apply) <input checked="" type="checkbox"/> Qualifying small power production facility status <input type="checkbox"/> Qualifying cogeneration facility status 		
	1l What is the purpose and expected effective date(s) of this filing? <input type="checkbox"/> Original certification; facility expected to be installed by _____ and to begin operation on _____ <input checked="" type="checkbox"/> Change(s) to a previously certified facility to be effective on 12/31/19 (Identify type(s) of change(s) below, and describe change(s) in the Miscellaneous section starting on page 19) <input type="checkbox"/> Name change and/or other administrative change(s) <input checked="" type="checkbox"/> Change in ownership <input type="checkbox"/> Change(s) affecting plant equipment, fuel use, power production capacity and/or cogeneration thermal output <input type="checkbox"/> Supplement or correction to a previous filing submitted on _____ (describe the supplement or correction in the Miscellaneous section starting on page 19)  		
	1m If any of the following three statements is true, check the box(es) that describe your situation and complete the form to the extent possible, explaining any special circumstances in the Miscellaneous section starting on page 19. <input type="checkbox"/> The instant facility complies with the Commission's QF requirements by virtue of a waiver of certain regulations previously granted by the Commission in an order dated _____ (specify any other relevant waiver orders in the Miscellaneous section starting on page 19)  <input type="checkbox"/> The instant facility would comply with the Commission's QF requirements if a petition for waiver submitted concurrently with this application is granted <input type="checkbox"/> The instant facility complies with the Commission's regulations, but has special circumstances, such as the employment of unique or innovative technologies not contemplated by the structure of this form, that make the demonstration of compliance via this form difficult or impossible (describe in Misc. section starting on p. 19)		

Contact Information	2a Name of contact person Leanne Sim		2b Telephone number 8088662901	
	2c Which of the following describes the contact person's relationship to the applicant? (check one) <input type="checkbox"/> Applicant (self) <input type="checkbox"/> Employee, owner or partner of applicant authorized to represent the applicant <input checked="" type="checkbox"/> Employee of a company affiliated with the applicant authorized to represent the applicant on this matter <input type="checkbox"/> Lawyer, consultant, or other representative authorized to represent the applicant on this matter			
	2d Company or organization name (if applicant is an individual, check here and skip to line 2e) <input type="checkbox"/> Neighborhood Power Corporation			
	2e Street address (if same as Applicant, check here and skip to line 3a) <input checked="" type="checkbox"/>			
	2f City		2g State/province	
	2h Postal code		2i Country (if not United States)	
	Facility Identification and Location	3a Facility name Mt Hope Solar		
3b Street address (if a street address does not exist for the facility, check here and skip to line 3c) <input checked="" type="checkbox"/>				
3c Geographic coordinates: If you indicated that no street address exists for your facility by checking the box in line 3b, then you must specify the latitude and longitude coordinates of the facility in degrees (to three decimal places). Use the following formula to convert to decimal degrees from degrees, minutes and seconds: decimal degrees = degrees + (minutes/60) + (seconds/3600). See the "Geographic Coordinates" section on page 4 for help. If you provided a street address for your facility in line 3b, then specifying the geographic coordinates below is optional. Longitude <input type="checkbox"/> East (+) 122.613 degrees <input checked="" type="checkbox"/> West (-) Latitude <input checked="" type="checkbox"/> North (+) 45.126 degrees <input type="checkbox"/> South (-)				
3d City (if unincorporated, check here and enter nearest city) <input type="checkbox"/> Molalla		3e State/province Oregon		
3f County (or check here for independent city) <input type="checkbox"/> Clackamas		3g Country (if not United States)		
Transacting Utilities	Identify the electric utilities that are contemplated to transact with the facility.			
	4a Identify utility interconnecting with the facility Portland General Electric			
	4b Identify utilities providing wheeling service or check here if none <input checked="" type="checkbox"/>			
	4c Identify utilities purchasing the useful electric power output or check here if none <input type="checkbox"/> Portland General Electric			
4d Identify utilities providing supplementary power, backup power, maintenance power, and/or interruptible power service or check here if none <input type="checkbox"/> Portland General Electric				

Ownership and Operation

5a Direct ownership as of effective date or operation date: Identify all direct owners of the facility holding at least 10 percent equity interest. For each identified owner, also (1) indicate whether that owner is an electric utility, as defined in section 3(22) of the Federal Power Act (16 U.S.C. 796(22)), or a holding company, as defined in section 1262(8) of the Public Utility Holding Company Act of 2005 (42 U.S.C. 16451(8)), and (2) for owners which are electric utilities or holding companies, provide the percentage of equity interest in the facility held by that owner. If no direct owners hold at least 10 percent equity interest in the facility, then provide the required information for the two direct owners with the largest equity interest in the facility.

Full legal names of direct owners	Electric utility or holding company	If Yes, % equity interest
1) Mt Hope Solar, LLC	Yes <input type="checkbox"/> No <input checked="" type="checkbox"/>	
2)	Yes <input type="checkbox"/> No <input type="checkbox"/>	
3)	Yes <input type="checkbox"/> No <input type="checkbox"/>	
4)	Yes <input type="checkbox"/> No <input type="checkbox"/>	
5)	Yes <input type="checkbox"/> No <input type="checkbox"/>	
6)	Yes <input type="checkbox"/> No <input type="checkbox"/>	
7)	Yes <input type="checkbox"/> No <input type="checkbox"/>	
8)	Yes <input type="checkbox"/> No <input type="checkbox"/>	
9)	Yes <input type="checkbox"/> No <input type="checkbox"/>	
10)	Yes <input type="checkbox"/> No <input type="checkbox"/>	

Check here and continue in the Miscellaneous section starting on page 19 if additional space is needed

5b Upstream (i.e., indirect) ownership as of effective date or operation date: Identify all upstream (i.e., indirect) owners of the facility that both (1) hold at least 10 percent equity interest in the facility, and (2) are electric utilities, as defined in section 3(22) of the Federal Power Act (16 U.S.C. 796(22)), or holding companies, as defined in section 1262(8) of the Public Utility Holding Company Act of 2005 (42 U.S.C. 16451(8)). Also provide the percentage of equity interest in the facility held by such owners. (Note that, because upstream owners may be subsidiaries of one another, total percent equity interest reported may exceed 100 percent.)

Check here if no such upstream owners exist.

Full legal names of electric utility or holding company upstream owners	% equity interest
1) OR Foss 2019 Solar Holdings, LLC	100
2)	
3)	
4)	
5)	
6)	
7)	
8)	
9)	
10)	

Check here and continue in the Miscellaneous section starting on page 19 if additional space is needed

5c Identify the facility operator
 Mt Hope Solar LLC

Energy Input

6a Describe the primary energy input: (check one main category and, if applicable, one subcategory)

<input type="checkbox"/> Biomass (specify)	<input checked="" type="checkbox"/> Renewable resources (specify)	<input type="checkbox"/> Geothermal
<input type="checkbox"/> Landfill gas	<input type="checkbox"/> Hydro power - river	<input type="checkbox"/> Fossil fuel (specify)
<input type="checkbox"/> Manure digester gas	<input type="checkbox"/> Hydro power - tidal	<input type="checkbox"/> Coal (not waste)
<input type="checkbox"/> Municipal solid waste	<input type="checkbox"/> Hydro power - wave	<input type="checkbox"/> Fuel oil/diesel
<input type="checkbox"/> Sewage digester gas	<input checked="" type="checkbox"/> Solar - photovoltaic	<input type="checkbox"/> Natural gas (not waste)
<input type="checkbox"/> Wood	<input type="checkbox"/> Solar - thermal	<input type="checkbox"/> Other fossil fuel (describe on page 19)
<input type="checkbox"/> Other biomass (describe on page 19)	<input type="checkbox"/> Wind	<input type="checkbox"/> Other (describe on page 19)
<input type="checkbox"/> Waste (specify type below in line 6b)	<input type="checkbox"/> Other renewable resource (describe on page 19)	

6b If you specified "waste" as the primary energy input in line 6a, indicate the type of waste fuel used: (check one)

Waste fuel listed in 18 C.F.R. § 292.202(b) (specify one of the following)

- Anthracite culm produced prior to July 23, 1985
- Anthracite refuse that has an average heat content of 6,000 Btu or less per pound and has an average ash content of 45 percent or more
- Bituminous coal refuse that has an average heat content of 9,500 Btu per pound or less and has an average ash content of 25 percent or more
- Top or bottom subbituminous coal produced on Federal lands or on Indian lands that has been determined to be waste by the United States Department of the Interior's Bureau of Land Management (BLM) or that is located on non-Federal or non-Indian lands outside of BLM's jurisdiction, provided that the applicant shows that the latter coal is an extension of that determined by BLM to be waste
- Coal refuse produced on Federal lands or on Indian lands that has been determined to be waste by the BLM or that is located on non-Federal or non-Indian lands outside of BLM's jurisdiction, provided that applicant shows that the latter is an extension of that determined by BLM to be waste
- Lignite produced in association with the production of montan wax and lignite that becomes exposed as a result of such a mining operation
- Gaseous fuels (except natural gas and synthetic gas from coal) (describe on page 19)
- Waste natural gas from gas or oil wells (describe on page 19 how the gas meets the requirements of 18 C.F.R. § 2.400 for waste natural gas; include with your filing any materials necessary to demonstrate compliance with 18 C.F.R. § 2.400)
- Materials that a government agency has certified for disposal by combustion (describe on page 19)
- Heat from exothermic reactions (describe on page 19)
- Residual heat (describe on page 19)
- Used rubber tires
- Plastic materials
- Refinery off-gas
- Petroleum coke

Other waste energy input that has little or no commercial value and exists in the absence of the qualifying facility industry (describe in the Miscellaneous section starting on page 19; include a discussion of the fuel's lack of commercial value and existence in the absence of the qualifying facility industry)

6c Provide the average energy input, calculated on a calendar year basis, in terms of Btu/h for the following fossil fuel energy inputs, and provide the related percentage of the total average annual energy input to the facility (18 C.F.R. § 292.202(j)). For any oil or natural gas fuel, use lower heating value (18 C.F.R. § 292.202(m)).

Fuel	Annual average energy input for specified fuel	Percentage of total annual energy input
Natural gas	0 Btu/h	0 %
Oil-based fuels	0 Btu/h	0 %
Coal	0 Btu/h	0 %

Technical Facility Information	Indicate the maximum gross and maximum net electric power production capacity of the facility at the point(s) of delivery by completing the worksheet below. Respond to all items. If any of the parasitic loads and/or losses identified in lines 7b through 7e are negligible, enter zero for those lines.	
	7a The maximum gross power production capacity at the terminals of the individual generator(s) under the most favorable anticipated design conditions	2,500 kW
	7b Parasitic station power used at the facility to run equipment which is necessary and integral to the power production process (boiler feed pumps, fans/blowers, office or maintenance buildings directly related to the operation of the power generating facility, etc.). If this facility includes non-power production processes (for instance, power consumed by a cogeneration facility's thermal host), do not include any power consumed by the non-power production activities in your reported parasitic station power.	10 kW
	7c Electrical losses in interconnection transformers	15 kW
	7d Electrical losses in AC/DC conversion equipment, if any	0 kW
	7e Other interconnection losses in power lines or facilities (other than transformers and AC/DC conversion equipment) between the terminals of the generator(s) and the point of interconnection with the utility	0 kW
	7f Total deductions from gross power production capacity = 7b + 7c + 7d + 7e	25.0 kW
	7g Maximum net power production capacity = 7a - 7f	2,475.0 kW
	7h Description of facility and primary components: Describe the facility and its operation. Identify all boilers, heat recovery steam generators, prime movers (any mechanical equipment driving an electric generator), electrical generators, photovoltaic solar equipment, fuel cell equipment and/or other primary power generation equipment used in the facility. Descriptions of components should include (as applicable) specifications of the nominal capacities for mechanical output, electrical output, or steam generation of the identified equipment. For each piece of equipment identified, clearly indicate how many pieces of that type of equipment are included in the plant, and which components are normally operating or normally in standby mode. Provide a description of how the components operate as a system. Applicants for cogeneration facilities do not need to describe operations of systems that are clearly depicted on and easily understandable from a cogeneration facility's attached mass and heat balance diagram; however, such applicants should provide any necessary description needed to understand the sequential operation of the facility depicted in their mass and heat balance diagram. If additional space is needed, continue in the Miscellaneous section starting on page 19. <p style="background-color: #e6f2ff; padding: 5px;"> The facility will consist of photovoltaic modules affixed to ground mounted racks supported on driven piles. The system will utilize one or more inverters. </p>	

Information Required for Small Power Production Facility

If you indicated in line 1k that you are seeking qualifying small power production facility status for your facility, then you must respond to the items on this page. Otherwise, skip page 10.

Certification of Compliance with Size Limitations	<p>Pursuant to 18 C.F.R. § 292.204(a), the power production capacity of any small power production facility, together with the power production capacity of any other small power production facilities that use the same energy resource, are owned by the same person(s) or its affiliates, and are located at the same site, may not exceed 80 megawatts. To demonstrate compliance with this size limitation, or to demonstrate that your facility is exempt from this size limitation under the Solar, Wind, Waste, and Geothermal Power Production Incentives Act of 1990 (Pub. L. 101-575, 104 Stat. 2834 (1990) <i>as amended by</i> Pub. L. 102-46, 105 Stat. 249 (1991)), respond to lines 8a through 8e below (as applicable).</p>																
	<p>8a Identify any facilities with electrical generating equipment located within 1 mile of the electrical generating equipment of the instant facility, and for which any of the entities identified in lines 5a or 5b, or their affiliates, holds at least a 5 percent equity interest.</p> <p>Check here if no such facilities exist. <input checked="" type="checkbox"/></p>																
	<table border="1" style="width: 100%; border-collapse: collapse;"> <thead> <tr> <th style="width: 30%;">Facility location (city or county, state)</th> <th style="width: 15%;">Root docket # (if any)</th> <th style="width: 35%;">Common owner(s)</th> <th style="width: 20%;">Maximum net power production capacity</th> </tr> </thead> <tbody> <tr> <td>1) _____</td> <td>QF - _____</td> <td>_____</td> <td>_____ kW</td> </tr> <tr> <td>2) _____</td> <td>QF - _____</td> <td>_____</td> <td>_____ kW</td> </tr> <tr> <td>3) _____</td> <td>QF - _____</td> <td>_____</td> <td>_____ kW</td> </tr> </tbody> </table>	Facility location (city or county, state)	Root docket # (if any)	Common owner(s)	Maximum net power production capacity	1) _____	QF - _____	_____	_____ kW	2) _____	QF - _____	_____	_____ kW	3) _____	QF - _____	_____	_____ kW
	Facility location (city or county, state)	Root docket # (if any)	Common owner(s)	Maximum net power production capacity													
	1) _____	QF - _____	_____	_____ kW													
	2) _____	QF - _____	_____	_____ kW													
3) _____	QF - _____	_____	_____ kW														
<p><input type="checkbox"/> Check here and continue in the Miscellaneous section starting on page 19 if additional space is needed</p>																	
<p>8b The Solar, Wind, Waste, and Geothermal Power Production Incentives Act of 1990 (Incentives Act) provides exemption from the size limitations in 18 C.F.R. § 292.204(a) for certain facilities that were certified prior to 1995. Are you seeking exemption from the size limitations in 18 C.F.R. § 292.204(a) by virtue of the Incentives Act?</p> <p><input type="checkbox"/> Yes (continue at line 8c below) <input checked="" type="checkbox"/> No (skip lines 8c through 8e)</p>																	
<p>8c Was the original notice of self-certification or application for Commission certification of the facility filed on or before December 31, 1994? Yes <input type="checkbox"/> No <input type="checkbox"/></p>																	
<p>8d Did construction of the facility commence on or before December 31, 1999? Yes <input type="checkbox"/> No <input type="checkbox"/></p>																	
<p>8e If you answered No in line 8d, indicate whether reasonable diligence was exercised toward the completion of the facility, taking into account all factors relevant to construction? Yes <input type="checkbox"/> No <input type="checkbox"/> If you answered Yes, provide a brief narrative explanation in the Miscellaneous section starting on page 19 of the construction timeline (in particular, describe why construction started so long after the facility was certified) and the diligence exercised toward completion of the facility.</p>																	
Certification of Compliance with Fuel Use Requirements	<p>Pursuant to 18 C.F.R. § 292.204(b), qualifying small power production facilities may use fossil fuels, in minimal amounts, for only the following purposes: ignition; start-up; testing; flame stabilization; control use; alleviation or prevention of unanticipated equipment outages; and alleviation or prevention of emergencies, directly affecting the public health, safety, or welfare, which would result from electric power outages. The amount of fossil fuels used for these purposes may not exceed 25 percent of the total energy input of the facility during the 12-month period beginning with the date the facility first produces electric energy or any calendar year thereafter.</p>																
	<p>9a Certification of compliance with 18 C.F.R. § 292.204(b) with respect to uses of fossil fuel:</p> <p><input checked="" type="checkbox"/> Applicant certifies that the facility will use fossil fuels <i>exclusively</i> for the purposes listed above.</p>																
	<p>9b Certification of compliance with 18 C.F.R. § 292.204(b) with respect to amount of fossil fuel used annually:</p> <p>Applicant certifies that the amount of fossil fuel used at the facility will not, in aggregate, exceed 25 percent of the total energy input of the facility during the 12-month period beginning with the date the facility first produces electric energy or any calendar year thereafter.</p> <p><input checked="" type="checkbox"/></p>																

Information Required for Cogeneration Facility

If you indicated in line 1k that you are seeking qualifying cogeneration facility status for your facility, then you must respond to the items on pages 11 through 13. Otherwise, skip pages 11 through 13.

General Cogeneration Information	<p>Pursuant to 18 C.F.R. § 292.202(c), a cogeneration facility produces electric energy and forms of useful thermal energy (such as heat or steam) used for industrial, commercial, heating, or cooling purposes, through the sequential use of energy. Pursuant to 18 C.F.R. § 292.202(s), "sequential use" of energy means the following: (1) for a topping-cycle cogeneration facility, the use of reject heat from a power production process in sufficient amounts in a thermal application or process to conform to the requirements of the operating standard contained in 18 C.F.R. § 292.205(a); or (2) for a bottoming-cycle cogeneration facility, the use of at least some reject heat from a thermal application or process for power production.</p>																				
	<p>10a What type(s) of cogeneration technology does the facility represent? (check all that apply)</p> <p style="text-align: center;"> <input type="checkbox"/> Topping-cycle cogeneration <input type="checkbox"/> Bottoming-cycle cogeneration </p>																				
	<p>10b To help demonstrate the sequential operation of the cogeneration process, and to support compliance with other requirements such as the operating and efficiency standards, include with your filing a mass and heat balance diagram depicting average annual operating conditions. This diagram must include certain items and meet certain requirements, as described below. You must check next to the description of each requirement below to certify that you have complied with these requirements.</p>																				
	<table style="width: 100%; border-collapse: collapse;"> <thead> <tr> <th style="width: 30%; text-align: left; border-bottom: 1px solid black;">Check to certify compliance with indicated requirement</th> <th style="text-align: left; border-bottom: 1px solid black;">Requirement</th> </tr> </thead> <tbody> <tr> <td style="text-align: center; vertical-align: top;"><input type="checkbox"/></td> <td>Diagram must show orientation within system piping and/or ducts of all prime movers, heat recovery steam generators, boilers, electric generators, and condensers (as applicable), as well as any other primary equipment relevant to the cogeneration process.</td> </tr> <tr> <td style="text-align: center; vertical-align: top;"><input type="checkbox"/></td> <td>Any average annual values required to be reported in lines 10b, 12a, 13a, 13b, 13d, 13f, 14a, 15b, 15d and/or 15f must be computed over the anticipated hours of operation.</td> </tr> <tr> <td style="text-align: center; vertical-align: top;"><input type="checkbox"/></td> <td>Diagram must specify all fuel inputs by fuel type and average annual rate in Btu/h. Fuel for supplementary firing should be specified separately and clearly labeled. All specifications of fuel inputs should use lower heating values.</td> </tr> <tr> <td style="text-align: center; vertical-align: top;"><input type="checkbox"/></td> <td>Diagram must specify average gross electric output in kW or MW for each generator.</td> </tr> <tr> <td style="text-align: center; vertical-align: top;"><input type="checkbox"/></td> <td>Diagram must specify average mechanical output (that is, any mechanical energy taken off of the shaft of the prime movers for purposes not directly related to electric power generation) in horsepower, if any. Typically, a cogeneration facility has no mechanical output.</td> </tr> <tr> <td style="text-align: center; vertical-align: top;"><input type="checkbox"/></td> <td>At each point for which working fluid flow conditions are required to be specified (see below), such flow condition data must include mass flow rate (in lb/h or kg/s), temperature (in °F, R, °C or K), absolute pressure (in psia or kPa) and enthalpy (in Btu/lb or kJ/kg). Exception: For systems where the working fluid is <i>liquid only</i> (no vapor at any point in the cycle) and where the type of liquid and specific heat of that liquid are clearly indicated on the diagram or in the Miscellaneous section starting on page 19, only mass flow rate and temperature (not pressure and enthalpy) need be specified. For reference, specific heat at standard conditions for pure liquid water is approximately 1.002 Btu/(lb*R) or 4.195 kJ/(kg*K).</td> </tr> <tr> <td style="text-align: center; vertical-align: top;"><input type="checkbox"/></td> <td>Diagram must specify working fluid flow conditions at input to and output from each steam turbine or other expansion turbine or back-pressure turbine.</td> </tr> <tr> <td style="text-align: center; vertical-align: top;"><input type="checkbox"/></td> <td>Diagram must specify working fluid flow conditions at delivery to and return from each thermal application.</td> </tr> <tr> <td style="text-align: center; vertical-align: top;"><input type="checkbox"/></td> <td>Diagram must specify working fluid flow conditions at make-up water inputs.</td> </tr> </tbody> </table>	Check to certify compliance with indicated requirement	Requirement	<input type="checkbox"/>	Diagram must show orientation within system piping and/or ducts of all prime movers, heat recovery steam generators, boilers, electric generators, and condensers (as applicable), as well as any other primary equipment relevant to the cogeneration process.	<input type="checkbox"/>	Any average annual values required to be reported in lines 10b, 12a, 13a, 13b, 13d, 13f, 14a, 15b, 15d and/or 15f must be computed over the anticipated hours of operation.	<input type="checkbox"/>	Diagram must specify all fuel inputs by fuel type and average annual rate in Btu/h. Fuel for supplementary firing should be specified separately and clearly labeled. All specifications of fuel inputs should use lower heating values.	<input type="checkbox"/>	Diagram must specify average gross electric output in kW or MW for each generator.	<input type="checkbox"/>	Diagram must specify average mechanical output (that is, any mechanical energy taken off of the shaft of the prime movers for purposes not directly related to electric power generation) in horsepower, if any. Typically, a cogeneration facility has no mechanical output.	<input type="checkbox"/>	At each point for which working fluid flow conditions are required to be specified (see below), such flow condition data must include mass flow rate (in lb/h or kg/s), temperature (in °F, R, °C or K), absolute pressure (in psia or kPa) and enthalpy (in Btu/lb or kJ/kg). Exception: For systems where the working fluid is <i>liquid only</i> (no vapor at any point in the cycle) and where the type of liquid and specific heat of that liquid are clearly indicated on the diagram or in the Miscellaneous section starting on page 19, only mass flow rate and temperature (not pressure and enthalpy) need be specified. For reference, specific heat at standard conditions for pure liquid water is approximately 1.002 Btu/(lb*R) or 4.195 kJ/(kg*K).	<input type="checkbox"/>	Diagram must specify working fluid flow conditions at input to and output from each steam turbine or other expansion turbine or back-pressure turbine.	<input type="checkbox"/>	Diagram must specify working fluid flow conditions at delivery to and return from each thermal application.	<input type="checkbox"/>	Diagram must specify working fluid flow conditions at make-up water inputs.
	Check to certify compliance with indicated requirement	Requirement																			
	<input type="checkbox"/>	Diagram must show orientation within system piping and/or ducts of all prime movers, heat recovery steam generators, boilers, electric generators, and condensers (as applicable), as well as any other primary equipment relevant to the cogeneration process.																			
	<input type="checkbox"/>	Any average annual values required to be reported in lines 10b, 12a, 13a, 13b, 13d, 13f, 14a, 15b, 15d and/or 15f must be computed over the anticipated hours of operation.																			
	<input type="checkbox"/>	Diagram must specify all fuel inputs by fuel type and average annual rate in Btu/h. Fuel for supplementary firing should be specified separately and clearly labeled. All specifications of fuel inputs should use lower heating values.																			
	<input type="checkbox"/>	Diagram must specify average gross electric output in kW or MW for each generator.																			
	<input type="checkbox"/>	Diagram must specify average mechanical output (that is, any mechanical energy taken off of the shaft of the prime movers for purposes not directly related to electric power generation) in horsepower, if any. Typically, a cogeneration facility has no mechanical output.																			
<input type="checkbox"/>	At each point for which working fluid flow conditions are required to be specified (see below), such flow condition data must include mass flow rate (in lb/h or kg/s), temperature (in °F, R, °C or K), absolute pressure (in psia or kPa) and enthalpy (in Btu/lb or kJ/kg). Exception: For systems where the working fluid is <i>liquid only</i> (no vapor at any point in the cycle) and where the type of liquid and specific heat of that liquid are clearly indicated on the diagram or in the Miscellaneous section starting on page 19, only mass flow rate and temperature (not pressure and enthalpy) need be specified. For reference, specific heat at standard conditions for pure liquid water is approximately 1.002 Btu/(lb*R) or 4.195 kJ/(kg*K).																				
<input type="checkbox"/>	Diagram must specify working fluid flow conditions at input to and output from each steam turbine or other expansion turbine or back-pressure turbine.																				
<input type="checkbox"/>	Diagram must specify working fluid flow conditions at delivery to and return from each thermal application.																				
<input type="checkbox"/>	Diagram must specify working fluid flow conditions at make-up water inputs.																				

EPAcT 2005 Requirements for Fundamental Use of Energy Output from Cogeneration Facilities

EPAcT 2005 cogeneration facilities: The Energy Policy Act of 2005 (EPAcT 2005) established a new section 210(n) of the Public Utility Regulatory Policies Act of 1978 (PURPA), 16 USC 824a-3(n), with additional requirements for any qualifying cogeneration facility that (1) is seeking to sell electric energy pursuant to section 210 of PURPA and (2) was either not a cogeneration facility on August 8, 2005, or had not filed a self-certification or application for Commission certification of QF status on or before February 1, 2006. These requirements were implemented by the Commission in 18 C.F.R. § 292.205(d). Complete the lines below, carefully following the instructions, to demonstrate whether these additional requirements apply to your cogeneration facility and, if so, whether your facility complies with such requirements.

11a Was your facility operating as a qualifying cogeneration facility on or before August 8, 2005? Yes No

11b Was the initial filing seeking certification of your facility (whether a notice of self-certification or an application for Commission certification) filed on or before February 1, 2006? Yes No

If the answer to either line 11a or 11b is Yes, then continue at line 11c below. Otherwise, if the answers to both lines 11a and 11b are No, skip to line 11e below.

11c With respect to the design and operation of the facility, have any changes been implemented on or after February 2, 2006 that affect general plant operation, affect use of thermal output, and/or increase net power production capacity from the plant's capacity on February 1, 2006?

- Yes (continue at line 11d below)
- No. Your facility is not subject to the requirements of 18 C.F.R. § 292.205(d) at this time. However, it may be subject to these requirements in the future if changes are made to the facility. At such time, the applicant would need to recertify the facility to determine eligibility. Skip lines 11d through 11j.

11d Does the applicant contend that the changes identified in line 11c are not so significant as to make the facility a "new" cogeneration facility that would be subject to the 18 C.F.R. § 292.205(d) cogeneration requirements?

- Yes. Provide in the Miscellaneous section starting on page 19 a description of any relevant changes made to the facility (including the purpose of the changes) and a discussion of why the facility should not be considered a "new" cogeneration facility in light of these changes. Skip lines 11e through 11j.
- No. Applicant stipulates to the fact that it is a "new" cogeneration facility (for purposes of determining the applicability of the requirements of 18 C.F.R. § 292.205(d)) by virtue of modifications to the facility that were initiated on or after February 2, 2006. Continue below at line 11e.

11e Will electric energy from the facility be sold pursuant to section 210 of PURPA?

- Yes. The facility is an EPAcT 2005 cogeneration facility. You must demonstrate compliance with 18 C.F.R. § 292.205(d)(2) by continuing at line 11f below.
- No. Applicant certifies that energy will *not* be sold pursuant to section 210 of PURPA. Applicant also certifies its understanding that it must recertify its facility in order to determine compliance with the requirements of 18 C.F.R. § 292.205(d) *before* selling energy pursuant to section 210 of PURPA in the future. Skip lines 11f through 11j.

11f Is the net power production capacity of your cogeneration facility, as indicated in line 7g above, less than or equal to 5,000 kW?

- Yes, the net power production capacity is less than or equal to 5,000 kW. 18 C.F.R. § 292.205(d)(4) provides a rebuttable presumption that cogeneration facilities of 5,000 kW and smaller capacity comply with the requirements for fundamental use of the facility's energy output in 18 C.F.R. § 292.205(d)(2). Applicant certifies its understanding that, should the power production capacity of the facility increase above 5,000 kW, then the facility must be recertified to (among other things) demonstrate compliance with 18 C.F.R. § 292.205(d)(2). Skip lines 11g through 11j.
- No, the net power production capacity is greater than 5,000 kW. Demonstrate compliance with the requirements for fundamental use of the facility's energy output in 18 C.F.R. § 292.205(d)(2) by continuing on the next page at line 11g.

EPAct 2005 Requirements for Fundamental Use of Energy Output from Cogeneration Facilities (continued)

Lines 11g through 11k below guide the applicant through the process of demonstrating compliance with the requirements for "fundamental use" of the facility's energy output. 18 C.F.R. § 292.205(d)(2). Only respond to the lines on this page if the instructions on the previous page direct you to do so. Otherwise, skip this page.

18 C.F.R. § 292.205(d)(2) requires that the electrical, thermal, chemical and mechanical output of an EPAct 2005 cogeneration facility is used fundamentally for industrial, commercial, residential or institutional purposes and is not intended fundamentally for sale to an electric utility, taking into account technological, efficiency, economic, and variable thermal energy requirements, as well as state laws applicable to sales of electric energy from a qualifying facility to its host facility. If you were directed on the previous page to respond to the items on this page, then your facility is an EPAct 2005 cogeneration facility that is subject to this "fundamental use" requirement.

The Commission's regulations provide a two-pronged approach to demonstrating compliance with the requirements for fundamental use of the facility's energy output. First, the Commission has established in 18 C.F.R. § 292.205(d)(3) a "fundamental use test" that can be used to demonstrate compliance with 18 C.F.R. § 292.205(d)(2). Under the fundamental use test, a facility is considered to comply with 18 C.F.R. § 292.205(d)(2) if at least 50 percent of the facility's total annual energy output (including electrical, thermal, chemical and mechanical energy output) is used for industrial, commercial, residential or institutional purposes.

Second, an applicant for a facility that does not pass the fundamental use test may provide a narrative explanation of and support for its contention that the facility nonetheless meets the requirement that the electrical, thermal, chemical and mechanical output of an EPAct 2005 cogeneration facility is used fundamentally for industrial, commercial, residential or institutional purposes and is not intended fundamentally for sale to an electric utility, taking into account technological, efficiency, economic, and variable thermal energy requirements, as well as state laws applicable to sales of electric energy from a qualifying facility to its host facility.

Complete lines 11g through 11j below to determine compliance with the fundamental use test in 18 C.F.R. § 292.205(d)(3). Complete lines 11g through 11j *even if you do not intend to rely upon the fundamental use test to demonstrate compliance with 18 C.F.R. § 292.205(d)(2)*.

11g Amount of electrical, thermal, chemical and mechanical energy output (net of internal generation plant losses and parasitic loads) expected to be used annually for industrial, commercial, residential or institutional purposes and not sold to an electric utility	MWh
11h Total amount of electrical, thermal, chemical and mechanical energy expected to be sold to an electric utility	MWh
11i Percentage of total annual energy output expected to be used for industrial, commercial, residential or institutional purposes and not sold to a utility = 100 * 11g / (11g + 11h)	0 %

11j Is the response in line 11i greater than or equal to 50 percent?

Yes. Your facility complies with 18 C.F.R. § 292.205(d)(2) by virtue of passing the fundamental use test provided in 18 C.F.R. § 292.205(d)(3). Applicant certifies its understanding that, if it is to rely upon passing the fundamental use test as a basis for complying with 18 C.F.R. § 292.205(d)(2), then the facility must comply with the fundamental use test both in the 12-month period beginning with the date the facility first produces electric energy, and in all subsequent calendar years.

No. Your facility does not pass the fundamental use test. Instead, you must provide in the Miscellaneous section starting on page 19 a narrative explanation of and support for why your facility meets the requirement that the electrical, thermal, chemical and mechanical output of an EPAct 2005 cogeneration facility is used fundamentally for industrial, commercial, residential or institutional purposes and is not intended fundamentally for sale to an electric utility, taking into account technological, efficiency, economic, and variable thermal energy requirements, as well as state laws applicable to sales of electric energy from a QF to its host facility. Applicants providing a narrative explanation of why their facility should be found to comply with 18 C.F.R. § 292.205(d)(2) in spite of non-compliance with the fundamental use test may want to review paragraphs 47 through 61 of Order No. 671 (accessible from the Commission's QF website at www.ferc.gov/QF), which provide discussion of the facts and circumstances that may support their explanation. Applicant should also note that the percentage reported above will establish the standard that that facility must comply with, both for the 12-month period beginning with the date the facility first produces electric energy, and in all subsequent calendar years. See Order No. 671 at paragraph 51. As such, the applicant should make sure that it reports appropriate values on lines 11g and 11h above to serve as the relevant annual standard, taking into account expected variations in production conditions.

Information Required for Topping-Cycle Cogeneration Facility

If you indicated in line 10a that your facility represents topping-cycle cogeneration technology, then you must respond to the items on pages 14 and 15. Otherwise, skip pages 14 and 15.

Usefulness of Topping-Cycle Thermal Output	<p>The thermal energy output of a topping-cycle cogeneration facility is the net energy made available to an industrial or commercial process or used in a heating or cooling application. Pursuant to sections 292.202(c), (d) and (h) of the Commission's regulations (18 C.F.R. §§ 292.202(c), (d) and (h)), the thermal energy output of a qualifying topping-cycle cogeneration facility must be useful. In connection with this requirement, describe the thermal output of the topping-cycle cogeneration facility by responding to lines 12a and 12b below.</p>			
	<p>12a Identify and describe each thermal host, and specify the annual average rate of thermal output made available to each host for each use. For hosts with multiple uses of thermal output, provide the data for each use <i>in separate rows</i>.</p>			
		Name of entity (thermal host) taking thermal output	Thermal host's relationship to facility; Thermal host's use of thermal output	Average annual rate of thermal output attributable to use (net of heat contained in process return or make-up water)
	1)		Select thermal host's relationship to facility	
			Select thermal host's use of thermal output	Btu/h
	2)		Select thermal host's relationship to facility	
			Select thermal host's use of thermal output	Btu/h
	3)		Select thermal host's relationship to facility	
			Select thermal host's use of thermal output	Btu/h
	4)		Select thermal host's relationship to facility	
		Select thermal host's use of thermal output	Btu/h	
5)		Select thermal host's relationship to facility		
		Select thermal host's use of thermal output	Btu/h	
6)		Select thermal host's relationship to facility		
		Select thermal host's use of thermal output	Btu/h	
<input type="checkbox"/> Check here and continue in the Miscellaneous section starting on page 19 if additional space is needed				
<p>12b Demonstration of usefulness of thermal output: At a minimum, provide a brief description of each use of the thermal output identified above. In some cases, this brief description is sufficient to demonstrate usefulness. However, if your facility's use of thermal output is not common, and/or if the usefulness of such thermal output is not reasonably clear, then you must provide additional details as necessary to demonstrate usefulness. Your application may be rejected and/or additional information may be required if an insufficient showing of usefulness is made. (Exception: If you have previously received a Commission certification approving a specific use of thermal output related to the instant facility, then you need only provide a brief description of that use and a reference by date and docket number to the order certifying your facility with the indicated use. Such exemption may not be used if any change creates a material deviation from the previously authorized use.) If additional space is needed, continue in the Miscellaneous section starting on page 19.</p>				

Topping-Cycle Operating and Efficiency Value Calculation

Applicants for facilities representing topping-cycle technology must demonstrate compliance with the topping-cycle operating standard and, if applicable, efficiency standard. Section 292.205(a)(1) of the Commission's regulations (18 C.F.R. § 292.205(a)(1)) establishes the operating standard for topping-cycle cogeneration facilities: the useful thermal energy output must be no less than 5 percent of the total energy output. Section 292.205(a)(2) (18 C.F.R. § 292.205(a)(2)) establishes the efficiency standard for topping-cycle cogeneration facilities for which installation commenced on or after March 13, 1980: the useful power output of the facility plus one-half the useful thermal energy output must (A) be no less than 42.5 percent of the total energy input of natural gas and oil to the facility; and (B) if the useful thermal energy output is less than 15 percent of the total energy output of the facility, be no less than 45 percent of the total energy input of natural gas and oil to the facility. To demonstrate compliance with the topping-cycle operating and/or efficiency standards, or to demonstrate that your facility is exempt from the efficiency standard based on the date that installation commenced, respond to lines 13a through 13l below.





If you indicated in line 10a that your facility represents *both* topping-cycle and bottoming-cycle cogeneration technology, then respond to lines 13a through 13l below considering only the energy inputs and outputs attributable to the topping-cycle portion of your facility. Your mass and heat balance diagram must make clear which mass and energy flow values and system components are for which portion (topping or bottoming) of the cogeneration system.

13a Indicate the annual average rate of useful thermal energy output made available to the host(s), net of any heat contained in condensate return or make-up water	Btu/h
13b Indicate the annual average rate of net electrical energy output	kW
13c Multiply line 13b by 3,412 to convert from kW to Btu/h	0 Btu/h
13d Indicate the annual average rate of mechanical energy output taken directly off of the shaft of a prime mover for purposes not directly related to power production (this value is usually zero)	hp
13e Multiply line 13d by 2,544 to convert from hp to Btu/h	0 Btu/h
13f Indicate the annual average rate of energy input from natural gas and oil	Btu/h
13g Topping-cycle operating value = $100 * 13a / (13a + 13c + 13e)$	0 %
13h Topping-cycle efficiency value = $100 * (0.5*13a + 13c + 13e) / 13f$	0 %
13i Compliance with operating standard: Is the operating value shown in line 13g greater than or equal to 5%? <input type="checkbox"/> Yes (complies with operating standard) <input type="checkbox"/> No (does not comply with operating standard)	
13j Did installation of the facility in its current form commence on or after March 13, 1980? <input type="checkbox"/> Yes. Your facility is subject to the efficiency requirements of 18 C.F.R. § 292.205(a)(2). Demonstrate compliance with the efficiency requirement by responding to line 13k or 13l, as applicable, below. <input type="checkbox"/> No. Your facility is exempt from the efficiency standard. Skip lines 13k and 13l.	
13k Compliance with efficiency standard (for low operating value): If the operating value shown in line 13g is less than 15%, then indicate below whether the efficiency value shown in line 13h greater than or equal to 45%: <input type="checkbox"/> Yes (complies with efficiency standard) <input type="checkbox"/> No (does not comply with efficiency standard)	
13l Compliance with efficiency standard (for high operating value): If the operating value shown in line 13g is greater than or equal to 15%, then indicate below whether the efficiency value shown in line 13h is greater than or equal to 42.5%: <input type="checkbox"/> Yes (complies with efficiency standard) <input type="checkbox"/> No (does not comply with efficiency standard)	

Information Required for Bottoming-Cycle Cogeneration Facility

If you indicated in line 10a that your facility represents bottoming-cycle cogeneration technology, then you must respond to the items on pages 16 and 17. Otherwise, skip pages 16 and 17.

Usefulness of Bottoming-Cycle Thermal Output	The thermal energy output of a bottoming-cycle cogeneration facility is the energy related to the process(es) from which at least some of the reject heat is then used for power production. Pursuant to sections 292.202(c) and (e) of the Commission's regulations (18 C.F.R. § 292.202(c) and (e)), the thermal energy output of a qualifying bottoming-cycle cogeneration facility must be useful. In connection with this requirement, describe the process(es) from which at least some of the reject heat is used for power production by responding to lines 14a and 14b below.		
	14a Identify and describe each thermal host and each bottoming-cycle cogeneration process engaged in by each host. For hosts with multiple bottoming-cycle cogeneration processes, provide the data for each process <i>in separate rows</i> .		
	Name of entity (thermal host) performing the process from which at least some of the reject heat is used for power production	Thermal host's relationship to facility; Thermal host's process type	Has the energy input to the thermal host been augmented for purposes of increasing power production capacity? (if Yes, describe on p. 19)
	1)	Select thermal host's relationship to facility Select thermal host's process type	Yes <input type="checkbox"/> No <input type="checkbox"/>
	2)	Select thermal host's relationship to facility Select thermal host's process type	Yes <input type="checkbox"/> No <input type="checkbox"/>
	3)	Select thermal host's relationship to facility Select thermal host's process type	Yes <input type="checkbox"/> No <input type="checkbox"/>
<input type="checkbox"/> Check here and continue in the Miscellaneous section starting on page 19 if additional space is needed			
14b Demonstration of usefulness of thermal output: At a minimum, provide a brief description of each process identified above. In some cases, this brief description is sufficient to demonstrate usefulness. However, if your facility's process is not common, and/or if the usefulness of such thermal output is not reasonably clear, then you must provide additional details as necessary to demonstrate usefulness. Your application may be rejected and/or additional information may be required if an insufficient showing of usefulness is made. (Exception: If you have previously received a Commission certification approving a specific bottoming-cycle process related to the instant facility, then you need only provide a brief description of that process and a reference by date and docket number to the order certifying your facility with the indicated process. Such exemption may not be used if any material changes to the process have been made.) If additional space is needed, continue in the Miscellaneous section starting on page 19.			

Bottoming-Cycle Operating and Efficiency Value Calculation	<p>Applicants for facilities representing bottoming-cycle technology and for which installation commenced on or after March 13, 1990 must demonstrate compliance with the bottoming-cycle efficiency standards. Section 292.205(b) of the Commission's regulations (18 C.F.R. § 292.205(b)) establishes the efficiency standard for bottoming-cycle cogeneration facilities: the useful power output of the facility must be no less than 45 percent of the energy input of natural gas and oil for supplementary firing. To demonstrate compliance with the bottoming-cycle efficiency standard (if applicable), or to demonstrate that your facility is exempt from this standard based on the date that installation of the facility began, respond to lines 15a through 15h below.</p> <p>If you indicated in line 10a that your facility represents <i>both</i> topping-cycle and bottoming-cycle cogeneration technology, then respond to lines 15a through 15h below considering only the energy inputs and outputs attributable to the bottoming-cycle portion of your facility. Your mass and heat balance diagram must make clear which mass and energy flow values and system components are for which portion of the cogeneration system (topping or bottoming).</p>	
	<p>15a Did installation of the facility in its current form commence on or after March 13, 1980?</p> <p><input type="checkbox"/> Yes. Your facility is subject to the efficiency requirement of 18 C.F.R. § 292.205(b). Demonstrate compliance with the efficiency requirement by responding to lines 15b through 15h below.</p> <p><input type="checkbox"/> No. Your facility is exempt from the efficiency standard. Skip the rest of page 17.</p>	
	<p>15b Indicate the annual average rate of net electrical energy output</p>	kW
	<p>15c Multiply line 15b by 3,412 to convert from kW to Btu/h</p>	0 Btu/h 
	<p>15d Indicate the annual average rate of mechanical energy output taken directly off of the shaft of a prime mover for purposes not directly related to power production (this value is usually zero)</p>	hp
	<p>15e Multiply line 15d by 2,544 to convert from hp to Btu/h</p>	0 Btu/h 
	<p>15f Indicate the annual average rate of supplementary energy input from natural gas or oil</p>	Btu/h
	<p>15g Bottoming-cycle efficiency value = $100 * (15c + 15e) / 15f$</p>	0 % 
	<p>15h Compliance with efficiency standard: Indicate below whether the efficiency value shown in line 15g is greater than or equal to 45%:</p> <p><input type="checkbox"/> Yes (complies with efficiency standard) <input type="checkbox"/> No (does not comply with efficiency standard) </p>	

Miscellaneous

Use this space to provide any information for which there was not sufficient space in the previous sections of the form to provide. For each such item of information *clearly identify the line number that the information belongs to*. You may also use this space to provide any additional information you believe is relevant to the certification of your facility.

Your response below is not limited to one page. Additional page(s) will automatically be inserted into this form if the length of your response exceeds the space on this page. Use as many pages as you require.

With respect to line 5b, please note that Mt. Hope Solar, LLC (the "Applicant") is owned 100% by OR Foss 2019 Solar Holdings, LLC ("OR FOSS"), which also serves as the Manager of Applicant. OR FOSS is owned by 1% RSP OR, LLC ("RSP") and 99% Foss Quantum Fund, LLC ("FQF"). Although RSP owns 1% equity in OR FOSS, it acts as Manager with controlling, non-passive interest in OR FOSS. RSP is owned 50% by Neighborhood Power GP, LLC (which is wholly owned by Neighborhood Power Corporation) and 50% by Renewable Energy Alternatives, LLC, (which is owned by 42.5% SH REA Trust, 25% Michael W. Mills, LLC, 17.5% 4M REA Trust and 15% 5R REA Trust).

FQF holds a 99% passive interest in OR FOSS and, through OR FOSS, an indirect, passive, non-controlling interest in the Applicant, with only limited rights with respect to the actions of the Applicant and the Facility. See, e.g., AES Creative Resources, 129 FERC ¶61,239 at PP 26-28 (2009), Ad Hoc Renewable Energy Financing Group, 161 FERC ¶61,010 at PP 16-17 (2017). Because the passive interest does not afford FCF control of the dispatch or facility operations, neither FCF nor any of its upstream owners appear as upstream owners in Line 5b.



**Interconnection Agreement for Small Generator Facility
Tier 1, Tier 2, Tier 3 or Tier 4 Interconnection**

(Small Generator Facilities with Electric Nameplate Capacities of 10 MW or Less)

This Interconnection Agreement (sometimes also referred to as "Agreement") is made and entered into this 7th day of JANUARY, 2018 by and between Mt Hope Solar, LLC, an individual an Oregon limited liability company, ("Applicant") and Portland General Electric Company, a corporation existing under the laws of the State of Oregon, ("PGE"). Applicant and PGE each may be referred to as a "Party," or collectively as the "Parties."

Recitals:

Whereas, the Applicant is proposing to develop a Small Generator Facility, or to add generating capacity to an existing Small Generator Facility, consistent with the Application completed on December 13, 2017;

Whereas, the Applicant desires to interconnect the Small Generator Facility with PGE's Transmission and Distribution System (T&D System); and

Whereas, the Agreement shall be used for all approved Tier 1, Tier 2, Tier 3 and Tier 4 Interconnection Applications according to the procedures set forth in OPUC Rule OAR 860, Division 082 (Rule). Terms with initial capitalization, when used in this Agreement, shall have the meanings given in the Rule and, to the extent this Agreement conflicts with the Rule, the Rule shall take precedence.

Now, therefore, in consideration of and subject to the mutual covenants contained herein, the Parties agree as follows:

Article 1. Scope and Limitations of Agreement

1.1 Scope

The Agreement establishes standard terms and conditions approved by the Commission under which the Small Generator Facility with a Nameplate Capacity of 10 MW or less will interconnect to, and operate in parallel with PGE's T&D System. Additions, deletions or changes to the standard terms and conditions of an Interconnection Agreement will not be permitted unless they are mutually agreed to by the Parties or approved by the Commission if required by the Rule.

1.2 Power Purchase

The Agreement does not constitute an agreement to purchase, transmit, or deliver the Applicant's power nor does it constitute an electric service agreement.

1.3 Other Agreements

Nothing in the Interconnection Agreement is intended to affect any other agreement between PGE and the Applicant or another Interconnection Customer. However, in the event that the provisions of the Agreement are in conflict with the provisions of other PGE tariffs, PGE tariff shall control.

1.4 Responsibilities of the Parties

- 1.4.1 The Parties shall perform all obligations of this Agreement in accordance with all applicable laws.
- 1.4.2 The Applicant will construct, own, operate, and maintain its Small Generator Facility in accordance with the Agreement, IEEE Standard 1547 (2003 ed), the National Electrical Code (2005 ed) and applicable standards required by the Commission.
- 1.4.3 Each Party shall be responsible for the safe installation, maintenance, repair and condition of their respective lines and appurtenances on their respective sides of the Point of Interconnection. Each Party shall provide Interconnection Facilities that adequately protect the other Parties' facilities, personnel, and other persons from damage and injury. The allocation of responsibility for the design, installation, operation, maintenance and ownership of Interconnection Facilities is prescribed in the Rule.

1.5 Parallel Operation and Maintenance Obligations

Once the Small Generator Facility has been authorized to commence Parallel Operation by execution of the Interconnection Agreement, the Applicant will abide by all written provisions for operating and maintenance as required by the Rule and detailed by PGE in Form 7, title "Interconnection Equipment As Built Specifications, Initial Settings and Operating Requirements" a copy of which is provided on PGE's website.

1.6 Metering and Monitoring

The Interconnection Customer will be responsible for metering and monitoring as required by OAR 860-082-0070.

1.7 Power Quality

The Applicant will design its Small Generator Facility to maintain a composite power delivery at continuous rated power output at the Point of Interconnection that meets the requirements set forth in IEEE 1547. PGE may, in some circumstances, also require the Applicant to follow voltage or VAR schedules used by similarly situated, comparable generators in the control area. Any special operating requirements will be detailed in Form 7 provided on the Commission website and completed by PGE as required by the Rule. Under no circumstances shall these additional requirements for voltage or reactive power support exceed the normal operating capabilities of the Small Generator Facility. For purposes of this Agreement, "control area" shall mean an electrical system or systems bounded by interconnection metering and telemetry, capable of controlling generation to maintain its interchange schedule with other control areas and contributing to frequency regulation of the interconnection.

Article 2. Inspection, Testing, Authorization, and Right of Access

2.1 Equipment Testing and Inspection

The Applicant will test and inspect its Small Generator Facility Facilities prior to interconnection in accordance with IEEE 1547 Standards as provided for in the Rule. The Interconnection will not be final until the Witness Test and Certificate of Completion provisions in the Rule have been satisfied. Operation of the Small Generator Facility requires an-Interconnection Agreement; electricity sales require a Power Purchase Agreement.—To the extent that the Applicant decides to conduct interim testing of the Small Generator Facility prior to the Witness Test, it may request that PGE observe these tests and that these tests be deleted from the final Witness Test. If PGE agrees to send

qualified personnel to the Small Generator Facility to observe such interim testing, it will be doing so at its own expense unless the Parties agree otherwise

2.2 Right of Access

As provided in OAR 860-082-0020, PGE will have access to the Applicant's premises for any reasonable purpose in connection with the Interconnection Application and any Interconnection Agreement that is entered in to pursuant to this Rule or if necessary to meet the legal obligation to provide service to its customers. Access will be requested at reasonable hours and upon reasonable notice, or at any time without notice in the event of an emergency or hazardous condition.

Article 3. Effective Date, Term, Termination, and Disconnection

3.1 Effective Date

The Agreement shall become effective upon execution by the Parties.

3.2 Term of Agreement

The Agreement will be effective on the Effective Date and will remain in effect for a period of twenty (20) years or the life of the Power Purchase Agreement, whichever is shorter or a period mutually agreed to by Parties, unless terminated earlier by the default or voluntary termination by the Interconnection Customer or by action of the Commission.

3.3 Termination

No termination will become effective until the Parties have complied with all applicable laws and any clauses of the Rule or this Agreement applicable to such termination.

3.3.1 The Applicant may terminate this Agreement at any time by giving PGE twenty (20) business days written notice.

3.3.2 Either Party may terminate this Agreement after default pursuant to Article 5.6 of this Agreement.

3.3.3 The Commission may order termination of this Agreement.

3.3.4 Upon termination of this Agreement, the Small Generator Facility will be disconnected from PGE's T&D System at the Applicant's expense. The termination of this Agreement will not relieve either Party of its liabilities and obligations, owed or continuing at the time of the termination.

3.3.4 The provisions of this Article shall survive termination or expiration of this Agreement.

3.4 Temporary Disconnection

PGE or the Applicant may temporarily disconnect the Small Generator Facility from its T&D System for so long as reasonably necessary, as provided in OAR 860-082-0075 of the Rule, in the event one or more of the following conditions or events occurs:

3.4.1 Under emergency conditions, PGE or the Interconnection Customer may immediately suspend interconnection service and temporarily disconnect the Small Generator Facility. PGE shall notify the Applicant promptly when it becomes aware of an emergency condition that may reasonably be expected to affect the Small Generator Facility operation. The Applicant will notify PGE promptly when it becomes aware of an emergency condition that may reasonably be expected to affect PGE's T&D System. To the extent information is known, the notification shall describe the emergency condition, the extent of the damage or deficiency, the expected effect on the operation of both Parties' facilities and operations, its anticipated duration, and the necessary corrective action.

- 3.4.2 For routine Maintenance, Parties will make reasonable efforts to provide five (5) business days notice prior to interruption caused by routine maintenance or construction and repair to the Small Generator Facility or PGE's T&D system and shall use reasonable efforts to coordinate such interruption.
- 3.4.3 For Forced outages of the T&D System, PGE shall use reasonable efforts to provide the Applicant with prior notice of forced outages to effect immediate repairs to the T&D System. If prior notice is not given, PGE shall, upon request, provide the Applicant written documentation after the fact explaining the circumstances of the disconnection.
- 3.4.4 For disruption or deterioration of service, where PGE determines that operation of the Small Generator Facility will likely cause disruption or deterioration of service to other customers served from the same electric system, or if operating the Small Generator Facility could cause damage to PGE's T&D System, PGE may disconnect the Small Generator Facility. PGE will provide the Applicant upon request all supporting documentation used to reach the decision to disconnect. PGE may disconnect the Small Generator Facility if, after receipt of the notice, the Applicant fails to remedy the adverse operating effect within a reasonable time which shall be at least five (5) business days from the date the Applicant receives PGE's written notice supporting the decision to disconnect, unless emergency conditions exist, in which case the provisions of 3.4.1 of the Agreement apply.
- 3.4.5 If the Applicant makes any change other than Minor Equipment Modifications without prior written authorization of PGE, PGE will have the right to temporarily disconnect the Small Generator Facility.

3.5 Restoration of Interconnection

The Parties shall cooperate with each other to restore the Small Generator Facility, Interconnection Facilities, and PGE's T&D System to their normal operating state as soon as reasonably practicable following any disconnection pursuant to section 3.4.

Article 4. Cost Responsibility and Billing

The Applicant is responsible for the application fee and for such facilities, equipment, modifications and upgrades as required in 860-082-0035.

4.1 Minor T&D System Modifications

Modifications to the existing T&D System identified by PGE and set forth in Attachment A, such as changing meters, fuses or relay settings, are deemed Minor Modifications. It is PGE's sole discretion to decide what constitutes a Minor Modification. The Applicant will bear the costs of making such Minor Modifications as may be necessary to gain approval of an Application.

4.2 Interconnection Facilities

PGE will identify, under the study procedures of an Application review, the Interconnection Facilities necessary to safely interconnect the Small Generator Facility with PGE. Attachment A itemizes the Interconnection Facilities for the Applicant, including the cost of the facilities and the time required to build and install those facilities. The Applicant is responsible for the cost of the Interconnection Facilities.

4.3 Interconnection Equipment

The Applicant is responsible for all reasonable expenses, including overheads, associated with owning, operating, maintaining, repairing, and replacing its Interconnection Equipment.

4.4 System Upgrades

PGE will design, procure, construct, install, and own any System Upgrades. The actual cost of the System Upgrades, including overheads, is set forth in Attachment A and will be directly assigned to the Applicant. An Interconnection Customer may be entitled to financial compensation from other PGE Interconnection Customers who, in the future, benefit from the System Upgrades paid for by the Interconnection Customer. Such compensation will be governed by separate rules promulgated by the Commission or by terms of a tariff filed and approved by the Commission. Such compensation will only be available to the extent provided for in the separate rules or tariff.

4.5 Adverse System Impact

PGE is responsible for identifying Adverse System Impacts on any Affected Systems and for determining what mitigation activities or upgrades may be required to accommodate a Small Generator Facility. The actual cost of any actions taken to address the Adverse System Impacts, including overheads, shall be directly assigned to the Applicant. The Applicant may be entitled to financial compensation from other public utilities or other Interconnection Customers who, in the future, utilize the upgrades paid for by the Applicant, to the extent as allowed by the Commission. Adverse System Impacts are set forth in Attachment A.

4.6 Billings

PGE may require a deposit of not more than 50% of the cost estimate, not to exceed \$1,000, to be paid up front by the Applicant for studies necessary to complete an Application and to interconnect the Small Generator Facility to the T&D System. PGE may require a deposit of no more than 25% of the estimated costs, not to exceed \$10,000, for Interconnection Facilities necessary to complete an Application and to interconnect the Small Generator Facility to the T&D System. Progress billing, final billing and payment schedules must be agreed to by Parties prior to commencing work.

Article 5. Assignment, Liability, Indemnity, Force Majeure, Consequential Damages, and Default

5.1 Assignment

The Interconnection Agreement may be assigned by either Party upon fifteen (15) business days prior written notice. Except as provided in Articles 5.1.1 and 5.1.2, said assignment shall only be valid upon the prior written consent of the non-assigning Party, which consent shall not be unreasonably withheld.

5.1.1 Either Party may assign the Agreement without the consent of the other Party to any affiliate (which shall include a merger of the Party with another entity), of the assigning Party with an equal or greater credit rating and with the legal authority and operational ability to satisfy the obligations of the assigning Party under this Agreement;

5.1.2 The Applicant shall have the right to assign the Agreement, without the consent of PGE, for collateral security purposes to aid in providing financing for the Small Generator Facility. For Small Generator systems that are integrated into a building facility, the sale of the building or property will result in an automatic transfer of

the Agreement to the new owner who shall be responsible for complying with the terms and conditions of this Agreement.

- 5.1.3 Any attempted assignment that violates this Article is void and ineffective. Assignment shall not relieve a Party of its obligations, nor shall a Party's obligations be enlarged, in whole or in part, by reason thereof. An assignee is responsible for meeting the same obligations as the Applicant.

5.2 Limitation of Liability and Consequential Damages

A Party is liable for any loss, cost claim, injury, or expense including reasonable attorney's fees related to or arising from any act or omission in its performance of the provisions of an Interconnection Agreement entered into pursuant to the Rule except as provided for in ORS 757.300(4)(c). Neither Party will seek redress from the other Party in an amount greater than the amount of direct damage actually incurred.

5.3 Indemnity

- 5.3.1 This provision protects each Party from liability incurred to third parties as a result of carrying out the provisions of the Agreement. Liability under this provision is exempt from the general limitations on liability found in Article 5.2.
- 5.3.2 Each Party shall, to the extent allowed by law, and subject to the limitations imposed by ORS 30.260 to ORS 30.300, if applicable, at all times indemnify, defend, and hold the other Party harmless from, any and all damages, losses, claims, including claims and actions relating to injury to or death of any person or damage to property, demands, suits, recoveries, costs and expenses, court costs, attorney fees at trial and on appeal, and all other obligations by or to third parties (hereinafter "Harm"), arising out of or resulting from its negligent action or failure to meet its obligations under this Agreement. Such indemnity obligation shall be limited to the proportional extent the Harm is caused by the negligence of the indemnified Party.
- 5.3.3 If an indemnified person is entitled to indemnification under this Article as a result of a claim by a third party, and the indemnifying Party fails, after notice and reasonable opportunity to proceed under this Article, to assume the defense of such a claim, such indemnified person may at the expense of the indemnifying Party contest, settle or consent to the entry of any judgment with respect to, or pay in full, such claim.
- 5.3.4 If an indemnifying party is obligated to indemnify and hold any indemnified person harmless under this Article, the amount owing to the indemnified person shall be the amount of such indemnified person's actual loss, net of any insurance or other recovery.
- 5.3.5 Promptly after receipt by an indemnified person of any claim or notice of the commencement of any action or administrative or legal proceeding or investigation as to which the indemnity provided for in this Article may apply, the indemnified person shall notify the indemnifying party of such fact. Any failure of or delay in such notification shall not affect a Party's indemnification obligation unless such failure or delay is materially prejudicial to the indemnifying party.
- 5.3.6 The indemnifying Party shall have the right to assume the defense thereof with counsel designated by such indemnifying Party and reasonably satisfactory to the indemnified person. If the defendants in any such action include one or more indemnified persons and the indemnifying Party and if the indemnified person reasonably concludes that there may be legal defenses available to it and/or other

indemnified persons which are different from or additional to those available to the indemnifying Party, the indemnified person shall have the right to select separate counsel to assert such legal defenses and to otherwise participate in the defense of such action on its own behalf. In such instances, the indemnifying Party shall only be required to pay the fees and expenses of one additional attorney to represent an indemnified person or indemnified persons having such differing or additional legal defenses.

- 5.3.7 The indemnified person shall be entitled, at its expense, to participate in any such action, suit or proceeding, the defense of which has been assumed by the indemnifying Party. Notwithstanding the foregoing, the indemnifying Party (i) shall not be entitled to assume and control the defense of any such action, suit or proceedings if and to the extent that, in the opinion of the indemnified person and its counsel, such action, suit or proceeding involves the potential imposition of criminal liability on the indemnified person, or there exists a conflict or adversity of interest between the indemnified person and the indemnifying Party, in such event the indemnifying Party shall pay the reasonable expenses of the indemnified person, and (ii) shall not settle or consent to the entry of any judgment in any action, suit or proceeding without the consent of the indemnified person, which shall not be reasonably withheld, conditioned or delayed.

5.4 Consequential Damages

Neither Party shall be liable to the other Party, under any provision of the Agreement, for any losses, damages, costs or expenses for any special, indirect, incidental, consequential, or punitive damages, including but not limited to loss of profit or revenue, loss of the use of equipment, cost of capital, cost of temporary equipment or services, whether based in whole or in part in contract, in tort, including negligence, strict liability, or any other theory of liability; provided, however, that damages for which a Party may be liable to the other Party under another agreement will not be considered to be special, indirect, incidental, or consequential damages hereunder.

5.5 Force Majeure

- 5.5.1 As used in this Agreement, a Force Majeure Event shall mean "any act of God, labor disturbance, act of the public enemy, war, acts of terrorism, insurrection, riot, fire, storm or flood, explosion, breakage or accident to machinery or equipment through no direct, indirect, or contributory act of a Party, any order, regulation or restriction imposed by governmental, military or lawfully established civilian authorities, or any other cause beyond a Party's control. A Force Majeure Event does not include an act of negligence or intentional wrongdoing."
- 5.5.2 If a Force Majeure Event prevents a Party from fulfilling any obligations under this Agreement, the Party affected by the Force Majeure Event (Affected Party) shall promptly notify the other Party of the existence of the Force Majeure Event. The notification must specify in reasonable detail the circumstances of the Force Majeure Event, its expected duration, and the steps that the Affected Party is taking to mitigate the effects of the event on its performance, and if the initial notification was verbal, it should be promptly followed up with a written notification. The Affected Party shall keep the other Party informed on a continuing basis of developments relating to the Force Majeure Event until the event ends the Affected Party will be entitled to suspend or modify its performance of obligations under this

Agreement (other than the obligation to make payments) only to the extent that the effect of the Force Majeure Event cannot be reasonably mitigated. The Affected Party will use reasonable efforts to resume its performance as soon as possible. The Parties shall immediately report to the Commission should a Force Majeure Event prevent performance of an action required by Rule that the Rule does not permit the Parties to mutually waive.

5.6 Default

- 5.6.1 No default shall exist where such failure to discharge an obligation (other than the payment of money) is the result of a Force Majeure Event as defined in this Agreement, or the result of an act or omission of the other Party. Upon a default, the non-defaulting Party shall give written notice of such default to the defaulting Party. Except as provided in Article 5.6.2, the defaulting Party shall have sixty (60) calendar days from receipt of the default notice within which to cure such default; provided however, if such default is not capable of cure within sixty (60) calendar days, the defaulting Party shall commence such cure within twenty (20) calendar days after notice and continuously and diligently complete such cure within six (6) months from receipt of the default notice; and, if cured within such time, the default specified in such notice shall cease to exist.
- 5.6.2 If a default is not cured as provided for in this Article, or if a default is not capable of being cured within the period provided for herein, the non-defaulting Party shall have the right to terminate the Agreement by written notice at any time until cure occurs, and be relieved of any further obligation hereunder and, whether or not that Party terminates the Agreement, to recover from the defaulting Party all amounts due hereunder, plus all other damages and remedies to which it is entitled at law or in equity. Alternately, the non-defaulting Party shall have the right to seek dispute resolution pursuant to Article 7 with the Commission in lieu of default. The provisions of this Article will survive termination of the Agreement.

Article 6. Insurance

A Party is liable for any loss, cost claim, injury, or expense including reasonable attorney's fees related to or arising from any act or omission in its performance of the provisions of this Rule or the Interconnection Agreement entered into pursuant to this Rule.

- 6.1 Pursuant to the Rule adopted by the Commission, PGE may not require the Interconnection Customer to maintain general liability insurance in relation to the interconnection of a Small Generator Facility with an Electric Nameplate Capacity of 200 kW or less. With regard to the interconnection of a Small Generator Facility with an Electric Nameplate Capacity equal to or less than 10 MW but in excess of 200 kW, the Interconnection Customer shall, at its own expense, maintain in force throughout the period of this Agreement general liability insurance sufficient to protect any person (including PGE) who may be affected by the Interconnection Customer's Small Generator Facility and its operation and such insurance shall be sufficient to satisfy the Interconnection Customer's indemnification responsibilities under Article 5.3 of this Agreement.
- 6.2 Within ten (10) business days following execution of this Agreement, and as soon as practicable after the end of each fiscal year or at the renewal of the insurance policy and in any event within ninety (90) calendar days thereafter, the Interconnection Customer shall

- provide the Public Utility with certification of all insurance required in this Agreement, executed by each insurer or by an authorized representative of each insurer.
- 6.3** All insurance required by this Article 6 shall name the Public, its parent, associated and Affiliate companies and their respective directors, officers, agents, servants and employees ("Other Party Group") as additional insured. All policies shall contain provisions whereby the insurers waive all rights of subrogation against the Other Party Group and provide thirty (30) calendar days advance written notice to the Other Party Group prior to anniversary date of cancellation or any material change in coverage or condition. The Interconnection Customer's insurance shall contain provisions that specify that the policies are primary and shall apply to such extent without consideration for other policies separately carried and shall state that each insured is provided coverage as though a separate policy had been issued to each, except the insurer's liability shall not be increased beyond the amount for which the insurer would have been liable had only one insured been covered. The insurance policies, if written on a Claims First Made Basis, shall be maintained in full force and effect for two (2) years after termination of this Agreement, which coverage may be in the form of tail coverage or extended reporting period coverage if agreed by the Parties.
- 6.4** The Parties agree to report to each other in writing as soon as practical all accidents or occurrences resulting in injuries to any person, including death, and any property damage arising out of this Agreement.
- 6.5** The requirements contained herein as to insurance are not intended to and shall not in any manner limit or qualify the liabilities and obligations assumed by the Parties under this Agreement.

Article 7. Dispute Resolution

Parties will adhere to the dispute resolution provisions in OAR 860-082-0080.

Article 8. Miscellaneous

8.1 Governing Law, Regulatory Authority, and Rules

The validity, interpretation and enforcement of the Agreement and each of its provisions shall be governed by the laws of the State of Oregon, without regard to its conflicts of law principles. The Agreement is subject to all applicable laws. Each Party expressly reserves the right to seek changes in, appeal, or otherwise contest any laws, orders, or regulations of a governmental authority.

8.2 Amendment

The Parties may mutually agree to amend the Agreement by a written instrument duly executed by both Parties in accordance with provisions of the Rule and applicable Commission Orders and provisions of the laws if the State of Oregon.

8.3 No Third-Party Beneficiaries

The Agreement is not intended to and does not create rights, remedies, or benefits of any character whatsoever in favor of any persons, corporations, associations, or entities other than the Parties, and the obligations herein assumed are solely for the use and benefit of the Parties, their successors in interest and where permitted, their assigns.

8.4 Waiver

- 8.4.1 The failure of a Party to the Agreement to insist, on any occasion, upon strict performance of any provision of the Agreement will not be considered a waiver of any obligation, right, or duty of, or imposed upon, such Party.
- 8.4.2 The Parties may agree to mutually waive a section of this Agreement so long as prior Commission approval of the waiver is not required by the Rule.
- 8.4.3 Any waiver at any time by either Party of its rights with respect to the Agreement shall not be deemed a continuing waiver or a waiver with respect to any other failure to comply with any other obligation, right, or duty of the Agreement. Any waiver of the Agreement shall, if requested, be provided in writing.

8.5 Entire Agreement

The Interconnection Agreement, including any supplementary Form attachments that may be necessary, constitutes the entire Agreement between the Parties with reference to the subject matter hereof and supersedes all prior and contemporaneous understandings or agreements, oral or written, between the Parties with respect to the subject matter of the Agreement. There are no other agreements, representations, warranties, or covenants that constitute any part of the consideration for, or any condition to, either Party's compliance with its obligations under the Agreement.

8.6 Multiple Counterparts

The Agreement may be executed in two or more counterparts, each of which is deemed an original but all constitute one and the same instrument.

8.7 No Partnership

The Agreement will not be interpreted or construed to create an association, joint venture, agency relationship, or partnership between the Parties or to impose any partnership obligation or partnership liability upon either Party. Neither Party shall have any right, power or authority to enter into any agreement or undertaking for, or act on behalf of, or to act as or be an agent or representative of, or to otherwise bind, the other Party.

8.8 Severability

If any provision or portion of the Agreement shall for any reason be held or adjudged to be invalid or illegal or unenforceable by any court of competent jurisdiction or other governmental authority; (1) such portion or provision shall be deemed separate and independent; (2) the Parties shall negotiate in good faith to restore insofar as practicable the benefits to each Party that were affected by such ruling; and (3) the remainder of the Agreement shall remain in full force and effect.

8.9 Subcontractors

Nothing in the Agreement shall prevent a Party from utilizing the services of any subcontractor, or designating a third party agent as one responsible for a specific obligation or act required in the Agreement (collectively subcontractors), as it deems appropriate to perform its obligations under the Agreement; provided, however, that each Party will require its subcontractors to comply with all applicable terms and conditions of the Agreement in providing such services and each Party will remain primarily liable to the other Party for the performance of such subcontractor.

- 8.9.1 The creation of any subcontract relationship shall not relieve the hiring Party of any of its obligations under the Agreement. The hiring Party shall be fully responsible to the other Party for the acts or omissions of any subcontractor the hiring Party hires as if no subcontract had been made. Any applicable obligation imposed by the Agreement upon the hiring Party shall be equally binding upon, and will be construed as having application to, any subcontractor of such Party.

8.9.2 The obligations under this Article will not be limited in any way by any limitation of subcontractor's insurance.

8.10 Reservation of Rights

Either Party will have the right to make a unilateral filing with the Commission to modify the Interconnection Agreement. This reservation of rights provision will include but is not limited to modifications with respect to any rates terms and conditions, charges, classification of service, rule or regulation under tariff rates or any applicable State or Federal law or regulation. Each Party shall have the right to protest any such filing and to participate fully in any proceeding before the Commission in which such modifications may be considered.

Article 9. Notices and Records

9.1 General

Unless otherwise provided in the Agreement, any written notice, demand, or request required or authorized in connection with the Agreement shall be deemed properly given if delivered in person, delivered by recognized national courier service, or sent by first class mail, postage prepaid, to the person specified below:

If to the Applicant:

Applicant: MT. HOPE SOLAR, LLC
Attention: STEPHEN GATES
Address: 327 SE TACOMA ST #235
City: PORTLAND State: OR Zip: 97207
Phone: (808) 268-8090
Fax: (808) 215-9040
E-mail: sgates@aei; hbarhoodpower.com

If to PGE:

Attention: Small Power Production
Address: 121 SW Salmon St., 3WTC0402
City: Portland State: OR Zip: 97204
Phone: 503-464-8300
Fax: 503-464-2115
E-mail: small.powerproduction@pgn.com

9.2 Records

The utility will maintain a record of all Interconnection Agreements and related Form attachments for as long as the interconnection is in place as required by OAR 860-082-065. PGE will provide a copy of these records to the Applicant or Interconnection Customer within fifteen (15) business days if a request is made in writing.

9.3 Billing and Payment

Billings and payments shall be sent to the addresses set out below:

If to the Applicant (complete if different than Article 9.1 above):

Applicant: _____
Attention: _____
Address: _____
City: _____ State: _____ Zip: _____

If to PGE (complete if different than Article 9.1 above):

Attention: _____
Address: _____
City: _____ State: _____ Zip: _____

9.4 Designated Operating Representative

The Parties will designate operating representatives to conduct the communications which may be necessary or convenient for the administration of the operations provisions of the Agreement. This person will also serve as the point of contact with respect to operations and maintenance of the Party's facilities:

Applicant's Operating Representative (complete if different than Article 9.1 above):

Attention: _____
Address: _____
City: _____ State: _____ Zip: _____
Phone: _____
Fax: _____
E-mail: _____

PGE's Operating Representative (complete if different than Article 9.1 above):

Attention: _____
Address: _____
City: _____ State: _____ Zip: _____
Phone: _____
Fax: _____
E-mail: _____

9.5 Changes to the Notice Information

Either Party may change this notice information by giving five (5) business days written notice prior to the effective date of the change.

Article 10. Signatures

IN WITNESS WHEREOF, the Parties have caused the Agreement to be executed by their respective duly authorized representatives.

For the Applicant:

Signature:  _____

Printed Name: STEPHEN GATES

Title (if applicable): MANAGER

Date: 1/09/2019

For PGE:

Signature:  _____

Printed Name: Sarah Edmonds

Title: Director Transmission Svcs.

Date: 2-5-19

Attachment A

**Description and Costs of Minor Modifications, Interconnection Facilities,
System Upgrades, and Adverse System Impacts**

The following System Upgrades are required:

- Install a new primary service including a bi-direction meter and CT's.
- Reconductor 360 feet of existing 3ph overloaded 4/0GA_ACSR on Cascade Highway, extending south from the point of Interconnection.
- Rephase the C and B phase lateral downstream of Line Regualtor-354172 to B and A phase to mitigate overvoltage during light load conditions.
- Transfer Trip via SEL Mirror bits protocol.

The scope of work detailed below outlines the responsibilities of both PGE and the Interconnection Customer.

PGE's Responsibilities

PGE will engineer, procure, and install the new service conductor and metering equipment. However, the conduit and trench from the Point of Interconnection to the riser pole will be installed by the Interconnection Customer.

On the distribution system PGE will install the conductor on Cascade highway, in addition to carrying out the rephasing.

A transfer trip protection scheme will be engineered and installed by PGE. A fiber optic cable will run from the Molalla Substation to the point of interconnection along the existing distribution route. Approximately .20 miles of this distance is covered by a preceding interconnection. PGE's preferred method for transfer trip is SEL Mirror Bits Protocol. PGE will provide the settings for the Interconnection Customers relays prior to construction.

Interconnection Customers Responsibilities

For the new service the Interconnection Customer will need to trench and install 4" conduit from the Point of Interconnection to the riser pole in accordance with PGE's standards. Additionally, a pull rope will need to be placed in the conduit to allow PGE to pull in the new service conductors.

The Interconnection Customer will need to purchase and install a small vault along the same path as the conduit. The vault needs to be located between the outside fence of the generation facility and the riser pole. The vault will contain laterals, provided by PGE, that can be used as an isolation point for PGE crews. Vault specifications will be provided during the engineering of the new primary service.

The Interconnection Customer will also be responsible for the installation of the CT's. The CT's will be provided by PGE and wired by PGE after they have been installed.

The Interconnection Customer will be required to use dynamic reactive current support to mitigate voltage flicker on the feeder. The cost associated with dynamic reactive current support will be borne by the Interconnection Customer and is not included in PGE's cost Estimate.

The Interconnection Customer will also need to provide a separate communications cabinet to which the fiber optic cable and transfer trip devices can reside. The Interconnection Customer will be responsible for purchasing and installing the relays for transfer trip. Prior to testing, a copy of the setting must be provided to PGE for review.

New Primary Service and Metering Package	\$30,000.00
Distribution Requirements (Reconductor 360 feet, Rephasing)	\$59,503.00
Communication Requirements (Fiber Optic Line for Transfer Trip)	\$132,073.00
Protection Requirements (Work in substation to facilitate Transfer Trip)	\$36,000.00
Total	\$257,576.00

Attachment B

**Description of Interconnection Facilities
and Metering Equipment Operated or Maintained by the Public Utility**

PGE will only own the following interconnection equipment at the site:

- Primary voltage service conductors from PGE's area feeder circuit to the termination point in PV plant's switchgear, and
- Metering equipment (Meter, potential transformers, current transformers and associated wiring) that will be installed in the applicant-supplied switchgear.

Periodic maintenance of PGE owned equipment will be needed to ensure accuracy and function. The maintenance will occur on a regular cycle and be set forth by PGE. If at any time the equipment is damaged, the Applicant, or any subsequent assignees of this Agreement, may be held responsible for all associated costs. If at any point, the Applicant wishes to make any changes to the Interconnection Facilities that require PGE personnel or equipment, the Applicant is responsible for all associated costs.

The Applicant shall pay for the cost of the Interconnection Facilities itemized in this Agreement as well as engineering, procurement, construction, and commissioning costs of PGE provided interconnection facilities and distribution upgrades contemplated by this Agreement. The cost set forth herein is only for the scopes of work that will be performed by PGE. Costs for any work being performed by the Applicant or for any Applicant-owned, supplied and installed equipment and associated design and engineering are not included.

PGE will not perform services under this Agreement until payments are received by PGE as set forth under this Agreement. Payments must be received by PGE within thirty (30) calendar days of the issuance of PGE's invoice to Applicant. Applicant will be in default per Section 5.6 of the Agreement if PGE does not receive payment of any sum due to PGE within said (30) days.

Within one hundred and twenty (120) calendar days of completing the construction and installation of PGE's interconnection facilities and Distribution Upgrades described in this Agreement, PGE shall provide Applicant with a final accounting report of any difference between (1) the actual cost incurred to complete the construction and installation and the budget estimate provided to the Applicant and a written explanation for any significant variation; and (2) the Applicant's previous deposit and aggregate payments to PGE for such interconnection facilities and distribution upgrades. If the Applicant's cost responsibility exceeds its previous deposit and aggregate payments, PGE shall invoice the Applicant for the amount due and the Applicant shall make payment to PGE within thirty (30) calendar days. If the Applicant's previous deposit and aggregate payments exceed its cost responsibility under this Agreement, PGE shall refund to Applicant an amount equal to the difference within thirty (30) calendar days of the final accounting report.

The Applicant will acquire all necessary property rights and permits for the construction of the required facilities as well as distribution line easements (meeting PGE requirements), including easements for PGE's owned underground cable route for the new service.

Attachment C

One-Line Diagram

One-line diagram depicting the Generator Facility, Interconnection Facilities, metering equipment, and upgrades including safety lockout features and any special accessibility requirements.

To be filled in with as-built drawings later

Attachment D

Scope of Work/Milestones

In-Service Date: May 8, 2020

Critical milestones and responsibility as agreed to by the Parties:

	Milestone/Date	Responsible Party
(1)	<u>Executed Interconnection Agreement / 1-14-2019</u>	<u>Mt Hope Solar</u>
(2)	<u>\$10,000 of Estimated Cost / 1-14-2019</u>	<u>Mt Hope Solar</u>
(3)	<u>Engineering Starts / 2-15-2019</u>	<u>PGE</u>
(4)	<u>Payment of \$75,859 / 6-14-2019</u>	<u>Mt Hope Solar</u>
(5)	<u>*Engineering Complete / 6-14-2019</u>	<u>PGE</u>
(6)	<u>Payment of \$85,859 / 9-23-2019</u>	<u>Mt Hope Solar</u>
(7)	<u>PGE Orders Long Lead Time Items / 9-23-2019</u>	<u>PGE</u>
(8)	<u>Payment of \$85,858 / 1-3-2020</u>	<u>Mt Hope Solar</u>
(9)	<u>PGE Starts Construction / 1-3-2020</u>	<u>PGE</u>
(10)	<u>Switchgear Installed and Inspection / 3-16-2020</u>	<u>Mt Hope Solar</u>
(11)	<u>Interconnection Facilities Complete / 4-6-2020</u>	<u>PGE</u>
(12)	<u>Testing and Commissioning / 4-20-2020</u>	<u>Mt Hope Solar</u>
(13)	<u>In-Service Date / 5-8-2020</u>	<u>PGE</u>

* During the engineering of the communication scheme additional costs or time may be incurred should the existing utility poles need to be replaced or modified to accommodate the fiber optic line.

PGE does not guarantee completion of any project on a targeted date as the schedule is dependent on a number of variables, including but not limited to, construction of other potential interconnection projects.

EXHIBIT D
ENERGY DELIVERY SCHEDULE

Month	Average Energy (kWh)
January	133,100
February	210,000
March	248,500
April	494,000
May	609,400
June	634,500
July	766,600
August	680,300
September	529,600
October	306,900
November	147,600
December	108,100

Project Manager to provide an estimate of the average monthly Net Output of the Facility, and explain the basis for the estimate.

EXHIBIT E
PROJECT MANAGER AUTHORIZATION TO RELEASE
GENERATION DATA TO PORTLAND GENERAL ELECTRIC COMPANY

[Interconnection Customer Letterhead]

[DATE]

Director, Transmission Services
Portland General Electric Company
121 SW Salmon Street
Portland, OR 97204

To Whom it May Concern:

_____ (“Seller”) hereby voluntarily authorizes Portland General Electric Company's Transmission business unit to share Seller's interconnection information with marketing function employees of PGE, including but not limited to those in Energy Supply Management. Seller acknowledges that PGE did not provide it any preferences, either operational or rate-related, in exchange for this voluntary consent.
