

ZiPLY Fiber  
4155 SW Cedar Hills Blvd,  
Beaverton, OR 97005  
Jessica Epley  
M. (503) 431-0458  
jessica.epley@ziPLY.com



---

July 15, 2022

Sent via electronic mail to [puc.filingcenter@puc.oregon.gov](mailto:puc.filingcenter@puc.oregon.gov)

Attn: Filing Center  
Oregon Public Utilities Commission  
201 High Street S.E., Suite 100  
Salem, Oregon 97301

Re: Advice No. 2022-4 for ZiPLY Fiber Northwest, LLC dba ZiPLY Fiber

Dear Filing Center:

Enclosed for filing is ZiPLY Fiber Northwest, LLC dba ZiPLY Fiber's OPUC No. 13. This filing is submitted with an effective date of August 15, 2022.

A recent reformat of the tariff resulted in a change of all section numbers and page numbers. All rates and charges within the tariff remain the same.

Because of these format changes, we are replacing OPUC No. 12 in its entirety with OPUC No. 13.

If you have any questions regarding this filing, you may contact me at (503) 431-0458.

Sincerely,

A handwritten signature in black ink, appearing to read "JEpley".

Jessica Epley  
VP - Regulatory & External Affairs

<p><b>TARIFF</b></p> <p><b>OF</b></p> <p><b>ZIPLY FIBER NORTHWEST, LLC</b> <b>D/B/A ZIPLY FIBER</b></p> <p><b>Consisting of</b></p> <p><b>FACILITIES FOR INTRASTATE ACCESS</b></p>	
--	--

SECTION INDEX

<u>SECTION</u>	<u>DESCRIPTION</u>	<u>SHEET NO.</u>
<b>I.</b>	<b>INTRODUCTORY SHEETS AND DEFINITIONS</b>	
	Title Page	1
	Section Index	2
	Explanation of Symbols	12
	Explanation of Abbreviations	13
<b>II.</b>	<b>APPLICATION OF TARIFF</b>	
<b>III.</b>	<b>GENERAL REGULATIONS</b>	
	A. <u>Undertaking of the Company</u>	1
	1. <i>Scope</i>	1
	2. <i>Limitations</i>	1
	3. <i>Liability</i>	2
	4. <i>Provision of FIA</i>	3
	5. <i>Installation and Termination of FIA</i>	3
	6. <i>Maintenance of FIA</i>	3
	7. <i>Changes and Substitutions</i>	4
	8. <i>Discontinuance and Refusal of FIA</i>	4
	9. <i>Preemption of FIA</i>	5
	10. <i>Limitation of use of Metallic Facilities</i>	5
	B. <u>Use</u>	5
	1. <i>Interference or Impairment</i>	5
	2. <i>Unlawful Use of FIA</i>	6
	C. <u>Obligation of the Customer</u>	6
	1. <i>Damages</i>	6
	2. <i>Theft</i>	6
	3. <i>Equipment Space and Power</i>	7
	4. <i>Space and Power for Expanded Interconnection Service</i>	7
	5. <i>Availability for Testing</i>	7
	6. <i>Balance</i>	7
	7. <i>Design of Customer Services</i>	7
	8. <i>References to the Company</i>	7
	9. <i>Claims and Demands for Damages</i>	8
	10. <i>Coordination with Respect to Network Contingencies</i>	8
	11. <i>Identification and Rating of VoIP-PSTN Traffic</i>	8

---

**SECTION INDEX** (Continued)

D. <u>Payment Arrangements and Credit Allowances</u>	10
1. <i>Payment of Charges and Deposits</i>	10
2. <i>Minimum Periods</i>	12
3. <i>Cancellation of an ASR</i>	12
4. <i>Credit Allowance for FIA Interruptions</i>	12
5. <i>Termination Liability</i>	14
E. <u>Connections</u>	16
1. <i>General</i>	16
2. <i>Standard Access Service Connections</i>	16
3. <i>Expanded Interconnection Service (EIS) - Fiber Optic</i>	16
4. <i>Expanded Interconnection Service (EIS) - Microwave</i>	16
F. <u>Definitions</u>	17
G. <u>FIA Services Provided by More Than One Telephone Company</u>	38
1. <i>Single Company Billing</i>	38
2. <i>Meet Point Billing</i>	38

**IV. ORDERING OPTIONS FOR FIA**

A. <u>General</u>	1
1. <i>Ordering Conditions</i>	1
2. <i>Provision of Other Services</i>	6
3. <i>Special Connection</i>	6
4. <i>Expanded Interconnection Service (EIS)</i>	6
B. <u>Access Service Request</u>	6
1. <i>Service Date Intervals</i>	6
2. <i>ASR Modifications</i>	7
3. <i>Select of Facilities for Access Service</i>	9
4. <i>Minimum Period</i>	9
5. <i>Minimum Period Charges</i>	10
6. <i>Cancellation of an ASR</i>	10
7. <i>Discontinuance of Switched Access FGD or BSA-D</i>	13
8. <i>FGD or BSA-D Maximum Per Trunk Cancellation Charge</i>	13
C. <u>Access Service Requests for Services Provided by More Than One Telephone Company</u>	13
1. <i>Single Company Billing</i>	14
2. <i>Meet Point Billing</i>	14
D. <u>Switched Access Minimum Capacity Requirements</u>	14

---

SECTION INDEX (Continued)

**V. SWITCHED ACCESS**

A. <u>General</u>	1
B. <u>Terms and Conditions Exceptions</u>	1
C. <u>Rates and Charges</u>	1
1. <i>Nonrecurring Charges</i>	1
2. <i>Switched Transport</i>	2
3. <i>End Office Services</i>	5
4. <i>Information Surcharge</i>	5
5. <i>FGA or BSA-A Usage Sensitive Credit Allowance</i>	6
6. <i>CCS7 Access Service – Dedicated Switched Access</i>	6
7. <i>CCS7 Access Service – STP Port Termination</i>	6
8. <i>Assumed Minutes of Use Monthly Surrogate</i>	7
9. <i>Switched Access Cross Connect</i>	7
10. <i>Basic Service Elements</i>	7
11. <i>Carrier Identification Parameter (CIP)</i>	9

**VI. SPECIAL ACCESS**

A. <u>General</u>	1
1. <i>Rate Elements</i>	1
2. <i>Special Access Configurations</i>	5
3. <i>Special Facilities Routing</i>	7
4. <i>Design Layout Report</i>	8
5. <i>Acceptance Testing</i>	8
6. <i>Ordering Conditions</i>	9
B. <u>Description of Special Access</u>	10
1. <i>Voiceband</i>	11
2. <i>Program Audio</i>	11
3. <i>Videoband</i>	12
4. <i>Wideband Analog</i>	13
5. <i>Wideband Data Service</i>	13
6. <i>High Capacity Digital</i>	13
7. <i>Digital Data Service</i>	14
8. <i>Miscellaneous Special Access Services</i>	14
C. <u>Description of Terminating Options</u>	15
1. <i>Narrowband</i>	15
2. <i>Voice Grade</i>	15
3. <i>Program Audio</i>	17
4. <i>Videoband</i>	17
5. <i>Wideband Data Service</i>	17
6. <i>High Capacity Digital</i>	17
7. <i>Digital Data Service (DDS)</i>	18

---

**SECTION INDEX** (Continued)

D. <u>Description of Supplemental Features</u>	19
1. <i>Bridging</i>	19
2. <i>Conditioning Arrangements – Data</i>	20
3. <i>Conditioning – Program Audio</i>	21
4. <i>Signaling Arrangements</i>	21
5. <i>Echo Control</i>	22
6. <i>Improved Return Loss</i>	23
7. <i>Voiceband Facility Switching Arrangement</i>	23
8. <i>Automatic Protection Switch</i>	23
9. <i>Improved Termination Option</i>	23
10. <i>Improved Equal Level Echo Path Loss Option – ELEPL-2</i>	24
E. <u>Description of Multiplexing Arrangements</u>	24
1. <i>Voice to Narrowband</i>	24
2. <i>Group to Voice</i>	24
3. <i>Supergroup to Group</i>	24
4. <i>Mastergroup to Supergroup</i>	25
5. <i>DS1 to Voice</i>	25
6. <i>DS1C to Voice</i>	25
7. <i>DS1C to DS1</i>	25
8. <i>DS3 to DS1</i>	25
9. <i>DS3C to DS1</i>	25
10. <i>Group to DS1</i>	26
11. <i>Digital Data Carrier Multiplexer</i>	26
12. <i>Digital Data Subrate Multiplexer</i>	26
F. <u>Rate Regulations</u>	26
1. <i>Types of Rates and Charges</i>	26
2. <i>Minimum Periods</i>	31
3. <i>Mileage Measurement</i>	31
4. <i>Moves</i>	32
5. <i>Rates and Charges on an Individual Case Basis</i>	33
6. <i>Hub Wire Centers</i>	33
7. <i>Shared Use Analog and Digital High Capacity Services</i>	34
8. <i>Temporary Videoband Service</i>	35
9. <i>High Capacity Digital DS1 and DS3 Optional Arrangements-Riders</i>	36
10. <i>High Voltage Protection</i>	37
11. <i>DS3 high Capacity Service</i>	39
12. <i>Optional Payment Plan (OPP) for FT1, Fiber Connect and DDS</i>	41
13. <i>Optional Payment Plan (OPP) for DS1</i>	43

---

**SECTION INDEX** (Continued)

G. <u>Rates and Charges</u>	45
1. <i>Special Access Ordering Charges</i>	45
2. <i>Voiceband Facilities</i>	45
3. <i>Program Audio (200-3500 Hz) Facilities</i>	47
4. <i>Program Audio (100-5000 Hz) Facilities</i>	47
5. <i>Program Audio (50-8000 Hz) Facilities</i>	47
6. <i>Program Audio (50-15000 Hz) Facilities</i>	48
7. <i>High Capacity Digital DS1 (1.544 Mbps) Facilities</i>	49
8. <i>High Capacity Digital DS1C (3.152 Mbps) Facilities</i>	50
9. <i>High Capacity Digital Fiber Connection (6.312 Mbps) Facilities</i>	50
10. <i>High Capacity Digital Fractional T1 (FT1) Facilities</i>	51
11. <i>High Capacity DS3 (44.736 Mbps) Facilities – Three System</i>	52
12. <i>High Capacity DS3 (44.736 Mbps) Facilities – Individual System</i>	53
13. <i>High Capacity DS3 (44.736 Mbps) Facilities – Optional Arrangement Rider</i>	53
14. <i>High Capacity DS3 (44.736 Mbps) Facilities – DS3 Multiplexer Cross Connect Arrangement</i>	53
15. <i>Digital Data Service Facilities</i>	54
16. <i>Multiplexing Arrangements</i>	55
17. <i>High Voltage Protection</i>	55
H. <u>Miscellaneous Special Access Services</u>	55
1. <i>Description of Service</i>	55
2. <i>Rates</i>	56
I. <u>Special Access Cross Connect for EIS</u>	56

**VII. MISCELLANEOUS SERVICES**

A. <u>General</u>	1
B. <u>Additional Labor</u>	1
1. <i>Overtime Installation</i>	1
2. <i>Overtime Repair</i>	1
3. <i>Additional Installation Testing</i>	2
4. <i>Standby</i>	2
5. <i>Testing and Maintenance with Other Telephone Companies</i>	2
6. <i>Charges for Additional Labor</i>	2
C. <u>Maintenance of Service Charge</u>	2
D. <u>Telecommunications Service Priority (TSP) System</u>	3
1. <i>Description of the Service</i>	3
2. <i>Obtaining TSP System Service</i>	3
3. <i>Provisioning Priority</i>	4
4. <i>Restoration Priority</i>	4
5. <i>Obligations of the Customer</i>	4
6. <i>Obligations of the Company</i>	5
7. <i>Rates and Charges</i>	6

---

**SECTION INDEX** (Continued)

E. <u>Presubscription</u>	7
1. <i>Pay Telephones – IntraLATA Equal Access</i>	7
2. <i>IPIC Charge Application</i>	7
3. <i>Unauthorized Primary IntraLATA Carrier (IPIC) Restoral Change</i>	7
4. <i>IntraLATA Presubscription Charge</i>	8
5. <i>Liability of the Company</i>	8
6. <i>Carrier Desired Due Date (ICDDD) for IPIC Installation</i>	8
7. <i>Rates and Charges</i>	9
F. <u>Additional Testing</u>	9
1. <i>Switched Access Testing</i>	9
2. <i>Special Access Testing</i>	12
3. <i>Rates and Charges</i>	13
G. <u>Provision of FIA Billing Information</u>	13
H. <u>End User List</u>	14
1. <i>Presubscription List</i>	14
2. <i>Snapshot List</i>	15
3. <i>Rates and Charges</i>	15
I. <u>Billing Name and Address Services (BNAS)</u>	15
1. <i>BNA and Data Gathering Services</i>	15
2. <i>End User Validation List</i>	16
3. <i>Rates and Charges</i>	18

**VIII. SPECIALIZED FIA OR ARRANGEMENTS**

**IX. ANCILLARY SERVICES**

A. <u>Service Offerings</u>	1
1. <i>Billing and Collection Services</i>	1
2. <i>Operator Services</i>	1
B. <u>Regulations</u>	1
1. <i>Undertaking of the Company</i>	1
2. <i>Obligations of the Customer</i>	2
3. <i>Payment Arrangements</i>	4



---

**SECTION INDEX (Continued)**

C. <u>Description of Ancillary Services</u>	5
1. <i>Call Recording Service</i>	5
2. <i>Message Processing Service</i>	6
3. <i>Assembly and Editing Service</i>	7
4. <i>Call Record Provision Service</i>	7
5. <i>Message Bill Processing Service</i>	7
6. <i>Bill Rendering Service</i>	8
7. <i>Message Investigation Service</i>	9
8. <i>Online Bill Pay</i>	9
9. <i>Fundamental Billing</i>	10
10. <i>Program Development Service</i>	10
11. <i>Inquiry Service</i>	11
D. <u>Rate Regulations</u>	11
1. <i>Billing and Collection Services</i>	11
2. <i>Operator Services</i>	14
E. <u>Rates and Charges</u>	16
1. <i>Billing and Collection Service</i>	16
2. <i>Operator Services</i>	16
<b>X. SPECIAL FACILITIES ROUTING OF FIA</b>	
A. <u>Description of Special Facilities Routing of FIA</u>	1
1. <i>Diversity</i>	1
2. <i>Avoidance</i>	1
3. <i>Cable-Only Facilities</i>	1
B. <u>Rates and Charges</u>	1
1. <i>Diversity</i>	1
2. <i>Avoidance</i>	2
3. <i>Diversity and Avoidance Combined</i>	2
4. <i>Cable-Only Facilities</i>	2
<b>XI. SPECIAL CONSTRUCTION</b>	
A. <u>General</u>	1
1. <i>Conditions Requiring Special Construction</i>	1
2. <i>Filing of Charges</i>	1
3. <i>Ownership of Facilities</i>	1
4. <i>Interval to Provide FIA</i>	2
5. <i>Special Construction Involving Interstate and Intrastate FIA</i>	2

---

**SECTION INDEX** (Continued)

B.	<u>Liabilities, Charges and Payments</u>	2
1.	<i>General</i>	2
2.	<i>Payment of Charges</i>	2
3.	<i>State/End of Billing</i>	2
4.	<i>Partial Payments</i>	2
5.	<i>Development of Liabilities and Charges</i>	3
6.	<i>Types of Contingent Liabilities</i>	3
7.	<i>Types of Charges</i>	4
8.	<i>Application of Charges</i>	12
C.	<u>Deferral of the In-Service of FIA</u>	12
1.	<i>General</i>	12
2.	<i>Construction Has Not Started</i>	13
3.	<i>Construction Has Started But is Not Complete</i>	13
4.	<i>Construction Complete</i>	13
<b>XII.</b>	<b>(RESERVED FOR FUTURE USE)</b>	
<b>XIII.</b>	<b>CARRIER COMMON LINE ACCESS SERVICE</b>	
A.	<u>General Description</u>	1
B.	<u>Description of Carrier Common Line Service</u>	1
1.	<i>Description</i>	1
2.	<i>Limitations</i>	1
C.	<u>Obligations of the Customer</u>	1
1.	<i>Switched Access Service Requirement</i>	1
2.	<i>Supervision</i>	1
D.	<u>Rate Regulations</u>	2
1.	<i>Description and Application of Rates</i>	2
2.	<i>Determination of Usage Subject to Carrier Common Line Charges</i>	4
3.	<i>Resold Services</i>	5
4.	<i>Transitional Billing Arrangements</i>	9
E.	<u>Rates and Charges</u>	10
<b>XIV.</b>	<b>(RESERVED FOR FUTURE USE)</b>	
<b>XV.</b>	<b>EXCEPTIONS TO FIA OFFERINGS</b>	
<b>XVI.</b>	<b>(RESERVED FOR FUTURE USE)</b>	

---

SECTION INDEX (Continued)

**XVII. COIN SERVICES**

A. <u>General</u>	1
B. <u>Service Description</u>	1
C. <u>Service Provisioning</u>	1
D. <u>Collection and Remittance of Coin Station Monies</u>	2
E. <u>Provision of Message Call detail Concerning Coin Station Monies</u>	2
F. <u>Payment of Coin Sent-Paid Monies</u>	2
1. <i>Bill Period Coin Revenue</i>	2
2. <i>Total Customer Coin Revenue</i>	3
3. <i>Recourse Adjustments</i>	3
4. <i>Payment of Net Customer Coin Revenue</i>	3
5. <i>Audit Provisions</i>	3

**XVIII. ADVANCED COMMUNICATIONS NETWORKS**

A. <u>General</u>	1
B. <u>Packet Switching Network Service</u>	1
1. <i>Service Description</i>	1
2. <i>Service Provisioning</i>	1
3. <i>Rate Regulations</i>	2
4. <i>Rates and Charges</i>	2
C. <u>Frame Relay Service</u>	3
1. <i>Service Description</i>	3
2. <i>Service Provisioning</i>	4
3. <i>Obligations of the Company</i>	5
4. <i>Obligations of the Customer</i>	5
5. <i>Rate Regulations</i>	5
6. <i>Rates and Charges</i>	9
D. <u>Asynchronous Transfer Mode (ATM) Service</u>	12
1. <i>Service Description</i>	12
2. <i>Service Provisioning</i>	13
3. <i>Obligations of the Telephone Company</i>	14
4. <i>Obligations of the Customer</i>	15
5. <i>Rate Regulations</i>	15
6. <i>Optional Payment Plan (OPP)</i>	16
7. <i>Rates and Charges</i>	19
E. <u>Transportation LAN Connection (TLC)</u>	22
1. <i>Service Description</i>	22
2. <i>Service Provisioning</i>	23
3. <i>Conditions</i>	23
4. <i>Description</i>	25
5. <i>Rate Regulation</i>	26
6. <i>Rates</i>	28

---

**SECTION INDEX** (Continued)

F. <u>Transport LAN Service (TLS)</u>	29
1. <i>Definitions</i>	29
2. <i>Service Description</i>	29
3. <i>Conditions</i>	31
4. <i>Service Level Agreements (SLA)</i>	33
5. <i>Application of Rates and Charges</i>	41
6. <i>Rates and Charges</i>	46
7.	

**XIX. EXPANDED INTERCONNECTION SERVICES**

A. <u>Service Description</u>	1
B. <u>Provision of EIS</u>	1
1. <i>General</i>	1
2. <i>Responsibility of the Company</i>	1
3. <i>Rights of the Company</i>	2
C. <u>Obligations of the Customer</u>	2
1. <i>Responsibility of the Customer</i>	2
2. <i>Mechanic's or Materialmen's Liens</i>	3
3. <i>Confidentiality</i>	3
4. <i>Network Outage, Damage and Reporting</i>	3
D. <u>Discontinuance of Service</u>	4
E. <u>Ordering Options for EIS</u>	4
1. <i>Virtual EIS Service</i>	4
2. <i>Microwave Services</i>	4
3. <i>Data Over Voice (DOV) Equipment</i>	4
F. <u>Virtual EIS</u>	5
1. <i>Availability of Service</i>	5
2. <i>Obligations of the Customer</i>	5
3. <i>Operation and Maintenance</i>	6
4. <i>Customer Terminating Equipment Requirements</i>	6
G. <u>Rate Regulations</u>	7
1. <i>Types of Rates and Charges</i>	7
2. <i>Minimum Periods</i>	9
H. <u>Virtual EIS Rates and Charges</u>	9
1. <i>Cable Rates and Charges</i>	9
2. <i>Equipment Rates and Charges</i>	10

**XX. PROMOTIONS**

---

**EXPLANATION OF SYMBOLS**

Whenever tariff sheets are filed, changes will be identified by the following symbols:

- (C) To signify changed listing, condition, rule or regulation
- (D) To signify discontinued material
- (I) To signify increase
- (M) To signify material transferred from one sheet to another sheet of the same or a different schedule with no change in text, rate, condition, rule or regulation
- (N) To signify new material
- (R) To signify reduction
- (T) To signify change in text but no change in rate, condition, rule or regulation

**EXPLANATION OF ABBREVIATIONS**

AAM	-	Assumed Access Minutes
ac	-	alternating current
ACAT	-	Additional Cooperative Acceptance Testing
ACD	-	Automatic Call Distributor
ACNA	-	Access Customer Name Abbreviation
AIOD	-	Automatic Identification of Outward Dialed
AM	-	Access Minutes
ANI	-	Automatic Number Identification
ARD	-	Automatic Ringdown
ASR	-	Access Service Request
AST	-	Automatic Scheduled Testing
AT&TC	-	American Telephone and Telegraph Communications, Inc.
BHMC	-	Busy Hour Minutes of Capacity
BNA	-	Billing Name and Address
BNAS	-	Billing Name and Address Services
BP	-	Billing Percentage
BSA	-	Basic Serving Arrangement
BSE	-	Basic Service Element
CAC	-	Carrier Access Code
CCS	-	Centum Call-Seconds
CCSA	-	Common Control Switching Arrangement(s)
CCS7	-	Common Channel Signaling System 7 Network
CDL	-	Customer Designated Location
CDM	-	Call Days in Month
CIC	-	Carrier Identification Code
CIP	-	Carrier Identification Parameter
CMF	-	Chargeable Minimum Factor
CN	-	Charge Number
COMPS	-	Central Office Maintenance Planning System
Cont'd	-	Continued
CPN	-	Calling Party Number
CSP	-	Carrier Selection Parameter
CST	-	Cooperative Scheduled Testing
CSU	-	Circuit Switching Unit
DA	-	Digital Data Access
DAM	-	Distance in Airline Miles
dB	-	Decibel
dBm	-	Decibels below one milliwatt
dBm0	-	Transmission Level Referred to the Zero Transmission Level Point
dBrnC0	-	Decibel Reference Noise C-Message Weighted O dBv - Decibels Referred to One Volt
dc	-	direct current
DDS	-	Digital Data Service
DGS	-	Data Gathering Service
DTMF	-	Dual Tone Multifrequency
DX	-	Duplex

**EXPLANATION OF ABBREVIATIONS** (Continued)

ELEPL	-	Equal Level Echo Path Loss
E&M	-	The Receive and Transmit Leads of a Signaling System
EML	-	Expected Measured Loss
EPL	-	Echo Path Loss
ERL	-	Echo Return Loss
f	-	frequency
FCC	-	Federal Communications Commission
FCO	-	Foreign Central Office
FIA	-	Facilities for Intrastate Access
HC	-	High Capacity
Hz	-	Hertz
IA	-	Interface Arrangement
IAM	-	Initial Address Message
IC	-	Interexchange Carrier
ICB	-	Individual Case Basis
ICDDD	-	Carrier Desired Due Date
IDDD	-	International Direct Distance Dialing
ILP	-	Initial Liability Period
IP	-	Interconnection Point
IPIC	-	IntraLATA Primary Interexchange Carrier
kbps	-	kilobits per second
KhZ	-	kilohertz
LATA	-	Local Access and Transport Area
LEC	-	Local Exchange Carrier
Ma	-	Milliamperes
Mbps	-	Megabits per second
MHz	-	Megahertz
MJU	-	Multi-Junction Unit
MMC	-	Minimum Monthly Charge
MRC	-	Monthly Recurring Charge
MST	-	Manual Scheduled Testing
MTL	-	Maximum Termination Liability
MTS	-	Message Telecommunications Service
NA	-	Not Available
NANP	-	North American Numbering Plan
NECA	-	National Exchange Carrier Association
NPA	-	Numbering Plan Area
NRC	-	Nonrecurring Charge
NST	-	Nonscheduled Testing
NXX	-	Three Digit Central Office Code
OPS	-	Off-Premises Station
PBX	-	Private Branch Exchange
PCM	-	Pulse Code Modulation
PIC	-	InterLATA Primary Interexchange Carrier
POT	-	Point of Termination

**EXPLANATION OF ABBREVIATIONS** (Continued)

RMC	-	Recurring Monthly Charge
rms	-	root-mean-square
SF	-	Single Frequency
SP	-	Signaling Point
SRL	-	Singing Return Loss
SS7	-	Signaling System 7
STP	-	Signal Transport Point
STR	-	Switched Transport Rate
TDCF	-	Total Day Conversion Factor
TLP	-	Transmission Level Point
TV	-	Television
UL	-	Underutilization Liability
VG	-	Voice Grade
V&H	-	Vertical & Horizontal
WA	-	Wideband Analog
WATS	-	Wide Area Telecommunications Service



## II. APPLICATION OF TARIFF

<p>A. This tariff contains regulations, rates and charges applicable to Carrier Common Line, Switched Access, Special Access and Expanded Interconnection Service or, in combination, as Facilities for Intrastate Access, hereinafter referred to as FIA, provided by ZiPLY Fiber, hereinafter referred to as the Company, to InterLATA and IntraLATA customers, including, but not limited to, Interexchange Carriers (ICs), end users, and others subscribing to the services provided in this tariff. This tariff further provides for Ancillary and Miscellaneous Services. This tariff does not apply to other services offered by the Company.</p>	
<p>B. Regulations, rates and charges as specified in this tariff apply to FIA and shall not serve as a substitute for IC tariff offerings of services to end users. The provision of such FIA by the Company as set forth in this tariff does not constitute a joint undertaking with an IC for the furnishing of any service.</p>	
<p>C. Whenever reference is made in this tariff to other Oregon tariffs of the Company, the reference is to the tariffs in force as of the effective date of this tariff and to amendments thereto and successive issues thereof as approved by the Oregon Public Utilities Commission.</p>	

### III. GENERAL REGULATIONS

<p><b>A. <u>Undertaking of the Company</u></b></p>	
<p><b>1. <i>Scope</i></b></p>	
<p>a. The Company does not undertake to transmit calls under this tariff.</p>	
<p>b. The Company shall be responsible only for the installation, operation, and maintenance of the services which it provides.</p>	
<p>c. The Company will, for maintenance purposes, test its FIA only to the extent necessary to detect and/or clear troubles. Testing beyond normal parameters will be done as described in Section VII. following.</p>	
<p>d. FIA are provided twenty-four (24) hours daily, seven (7) days per week.</p>	
<p><b>2. <i>Limitations</i></b></p>	
<p>a. The customer may not assign or transfer the use of FIA provided under this tariff except that, where there is no interruption of use or relocation of the FIA, such assignment or transfer may be made to:</p>	
<p>(1) another customer, whether an individual, partnership, association or corporation, provided the assignee or transferee assumes all outstanding indebtedness for such FIA, and the unexpired portion of the minimum period and the termination liability applicable to such FIA, if any; or</p>	
<p>(2) a court appointed receiver, trustee or other person acting pursuant to law in bankruptcy, receivership, reorganization, insolvency, liquidation or other similar proceedings, provided the assignee or transferee assumes the unexpired portion of the minimum period and the termination liability applicable to such FIA, if any.</p>	
<p>In all cases of assignment or transfer, the written acknowledgment of the Company is required prior to such assignment or transfer which acknowledgment shall be made within fifteen (15) days from the receipt of notification. All regulations and conditions contained in this tariff shall apply to such assignee or transferee.</p>	
<p>The assignment or transfer of FIA does not relieve or discharge the assignor or transferor from remaining jointly or severally liable with the assignee or transferee for any obligations existing at the time of the assignment or transfer.</p>	
<p>b. The emergency provisioning and restoration of FIA shall be in accordance with 47 CFR § 64.401, which specifies the priority system for such activities. Section VII.D. describes the service arrangement.</p>	
<p>c. The Company does not warrant that its facilities and services meet standards other than those set forth in this tariff.</p>	

### III. GENERAL REGULATIONS (Continued)

<p>3. <i>Liability</i></p> <p>a. The Company's liability, if any, for willful misconduct is not limited by this tariff. With respect to any other claim or suit by a customer for damages associated with the installation, provision, termination, maintenance, repair or restoration of FIA, and subject to the provisions of <i>b.</i> through <i>d.</i>, the Company's liability, if any, shall not exceed an amount equal to the proportionate charge for the FIA for the period during which the provision of FIA was affected. This liability for damages shall be in addition to any amounts that may otherwise be due to the customer under this tariff as a credit allowance for a provision of FIA interruption.</p>	
<p>b. The Company shall not be liable for any act or omission of any other carrier or customer providing a portion of a service, nor shall the Company, for its own act or omission, hold liable any other carrier or customer providing a portion of a service.</p>	
<p>c. The Company shall be indemnified, defended and held harmless by the customer or end user against any claim, loss or damage arising from the use of FIA offered under this tariff. The foregoing indemnity shall issue on the customer or the end user separately, each being responsible for its own acts and omissions, involving:</p> <p>(1) Claims for libel, slander, invasion of privacy, or infringement of copyright arising from any communications;</p>	
<p>(2) Claims for patent infringement arising from combining or using the FIA furnished by the Company in connection with facilities or equipment furnished by the customer or end user; or</p>	
<p>(3) All other claims arising out of any act or omission of the customer or end user in the course of using FIA provided pursuant to this tariff.</p>	
<p>d. The Company does not guarantee or make any warranty with respect to its FIA when used in an explosive atmosphere. The Company shall be indemnified, defended and held harmless by the customer or end user from any and all claims by any person relating to the FIA so provided. The foregoing indemnity shall issue on the customer or the end user separately, each being responsible for its own acts and omissions.</p>	
<p>e. Except in the case of willful misconduct, under no circumstances whatever shall the Company be liable for indirect, incidental, special or consequential damages; and this disclaimer shall be effective notwithstanding any other provisions hereof.</p>	
<p>f. No license under patents is granted by the Company to the customer or shall be implied or arise by estoppel in the customer's favor with respect to any circuit, apparatus, system or method used by the customer in connection with FIA provided under this tariff. With respect to claims of patent infringement made by third persons, the Company will defend, indemnify, protect and save harmless the customer from and against all claims arising out of the use by the customer of FIA provided under this tariff.</p>	
<p>g. The Company's failure to provide or maintain FIA under this tariff shall be excused by labor difficulties, governmental orders, civil commotions, acts of God and other circumstances beyond the Company's reasonable control, subject to the interruption allowance provisions as specified in <i>III.D.4.</i></p>	

### III. GENERAL REGULATIONS (Continued)

<p>h. The Company shall reimburse the customer for damages to premises or equipment of the customer resulting from the provision of FIA by the Company on such premises, or by the installation or removal thereof, caused by the negligence or willful act of the Company.</p>	
<p>4. <i>Provision of FIA</i></p> <p>a. The Company, to the extent that such FIA are or can be made available with reasonable effort, and after provisions have been made for the Company's local service, will provide to the customer, upon reasonable notice, FIA offered in other applicable sections of this tariff at rates and charges specified therein.</p>	
<p>b. FIA provided to a customer under this tariff may be connected directly to customer facilities and/or may be connected to access facilities of another telephone company or companies in the joint provision of intrastate access.</p>	
<p>5. <i>Installation and Termination of FIA</i></p> <p>Except as provided for Expanded Interconnection Service specified in Section XIX., the FIA provided under this tariff: 1.) will include any entrance cable or drop wiring and wire or intrabuilding cable to that point where provision is made for termination of the Company's outside distribution network facilities at a suitable location inside a CDL, and 2.) will be installed by the Company to such point of termination.</p>	
<p>6. <i>Maintenance of FIA</i></p> <p>a. The FIA provided under this tariff shall be maintained by the Company. The customer or others may not rearrange, move, disconnect, remove or attempt to repair any FIA provided by the Company, other than by connection or disconnection to any interface means used, except with the written consent of the Company.</p>	
<p>b. Customer provided transmission facilities and equipment terminating in the Company wire center or access tandem for purposes of physical Expanded Interconnection Service (EIS), as described in Section XIX., will not be maintained by the Company. Customer provided facilities and equipment terminating in Company manhole or similar location for virtual EIS will be maintained by the Company.</p>	

### III. GENERAL REGULATIONS (Continued)

<p><b>7. Changes and Substitutions</b></p> <p>Except as provided for equipment and systems subject to 47 CFR § 68.110 (b), the Company may, where such action is reasonably required in the operation of its business, substitute, change, or rearrange any telephone plant used in providing FIA under this tariff, change minimum network protection criteria, change operating or maintenance characteristics of facilities, or change operations or procedures of the Company. In case of any such substitution, change or rearrangement, the facility parameters will be within generally accepted standards. The Company shall not be responsible if any such substitution, change or rearrangement renders any customer furnished services obsolete or requires modification or alteration thereof or otherwise affects their use or performance. If such substitution, change, or rearrangement materially affects the operating characteristics or technical parameters of the FIA, as originally ordered by the customer, the Company will notify the customer in writing prior to making such substitution, change or rearrangement. Notification will be given as follows:</p> <ul style="list-style-type: none"> <li>- Should a major change occur, the Company shall notify the customer at least one year in advance. A major change is described as any change in telephone plant which will affect the technical parameters of the interface (e.g., level, impedance, signaling, interface, bandwidth, two-wire, four-wire, etc.).</li> </ul>	
<ul style="list-style-type: none"> <li>- Should a minor change occur, the Company shall notify the customer at least thirty days in advance. A minor change is described as any change in telephone plant which will not affect the technical parameters of the interface (e.g., level, impedance, signaling, interface, bandwidth, two-wire, four-wire, etc.).</li> </ul>	
<p>The Company will work cooperatively with the customer relative to the redesign and implementation required by the change in operating characteristics.</p>	
<p><b>8. Discontinuance and Refusal of FIA</b></p> <p>a. Unless the provisions of <i>III.B.2.b.</i> apply, if the customer fails to comply with the provisions of <i>III.A.6.</i>, <i>III.C.1.</i>, and <i>III.D.1.d.</i>, or if applicable <i>III.E.3.</i> and <i>III.E.4.</i>, and <i>XIX.C.4.</i> including any payments to be made by it on the dates or at the times herein specified, and fails within thirty (30) days after written notice, by certified mail, from the Company to a person designated by the customer to correct such noncompliance, the Company may discontinue the provision of the FIA to the non-complying customer. In case of such discontinuance, all applicable charges shall become due.</p>	
<p>b. If the customer repeatedly fails to comply with the provisions of this tariff in connection with the provision of a FIA or group of FIA, and fails to correct such course of action after notice as set forth in <i>a.</i> preceding, the Company may refuse applications for additional FIA to the non-complying customer until the course of action is corrected.</p>	

**III. GENERAL REGULATIONS** (Continued)

<p>9. <i>Preemption of FIA</i></p> <p>In certain instances, i.e., when spare facilities and/or equipment are not available, it may be necessary to preempt existing services to provision or restore National Security Emergency Preparedness (NSEP) Services. If, in its best judgement, the Company deems it necessary to preempt, then the Company will ensure that:</p> <p>a. A sufficient number of public switched services are available for public use if preemption of such services is necessary to provision or restore NSEP Service.</p>	
<p>b. The service(s) preempted have a lower or do not contain NSEP assigned priority levels.</p>	
<p>c. A reasonable effort is made to notify the preempted service customer of the action to be taken.</p>	
<p>d. A credit allowance for any preempted service shall be made in accordance with the provisions set forth in Section III.D.4.a..</p>	
<p>10. <i>Limitation of Use of Metallic Facilities</i></p> <p>Except for loop and duplex (DX) type signaling, metallic facilities shall not be used for ground return or split pair operation. Signals applied to the metallic facility shall conform to minimum protection criteria for direct electrical connections as set forth in 47 CFR § 68.1 et al. In the case of applications of dc telegraph signaling systems, the customer shall be responsible, at its expense, for the provision of current limitation devices to protect the Company FIA from excessive current due to abnormal conditions and for the provision of noise mitigation networks when required to reduce excess noise.</p>	
<p>Interoffice metallic facilities are limited. The offering for DC (Metallic) and telegraph-grades facilities and services will be discontinued on October 25, 1991. Interoffice metallic facilities (wire pairs) are in diminishing supply, and can be expected to become less available as optical fiber is deployed and wire cables are removed. Following a one year written notification to customers, the Company reserves the right to convert customer requested metallic facilities to other types of outside plant facilities.</p>	
<p>B. <u>Use</u></p> <p>1. <i>Interference or impairment</i></p> <p>a. The characteristics and methods of operation of any circuits, facilities or equipment provided by other than the Company, including customer transmission equipment and facilities used with EIS, and associated with the FIA provided under this tariff shall not interfere with or impair service over any facilities of the Company, its connecting and concurring carriers, or other companies involved in its services, cause damage to their plant, impair the privacy of any communications carried over their facilities, or create hazards to their employees or to the public.</p>	

### III. GENERAL REGULATIONS (Continued)

<p>b. Except as provided for equipment or systems subject to 47 CFR § 68.108, if such characteristics or methods of operation are not in accordance with a. preceding, the Company will, where practicable, notify the customer, as appropriate, that temporary discontinuance of the use of FIA may be required; however, where prior notice is not practicable, nothing contained herein shall be deemed to preclude the Company's right to temporarily discontinue forthwith the use of FIA if such action is reasonable in the circumstances. In case of such temporary discontinuance the customer will be promptly notified and afforded the opportunity to correct the condition which gave rise to the temporary discontinuance. During such period of temporary discontinuance, allowance for interruption of FIA as set forth in <i>III.D.4.</i> following is not applicable.</p>	
<p><b>2. Unlawful Use of FIA</b></p> <p>The FIA are furnished subject to the condition that they will not be used for an unlawful purpose. FIA will be discontinued if any law enforcement agency, acting within its apparent jurisdiction, advises in writing that such FIA are being used in violation of law. The Company will refuse to furnish FIA when it has reasonable grounds to believe that such FIA will be used in violation of law.</p>	
<p><b>C. <u>Obligation of the Customer</u></b></p> <p><b>1. Damages</b></p> <p>The customer shall reimburse the Company for damages to the Company facilities utilized to provide FIA under this tariff caused by:</p> <ul style="list-style-type: none"> <li>- the negligence or willful act of the customer, or</li> </ul>	
<ul style="list-style-type: none"> <li>- the customer's improper use of the Company facilities, or</li> </ul>	
<ul style="list-style-type: none"> <li>- the malfunction of any facilities or equipment provided by other than the Company.</li> </ul>	
<p>Nothing in the foregoing provision shall be interpreted to hold one customer liable for another customer's actions. The Company will, upon reimbursement for damages, cooperate with the customer in prosecuting a claim against the person causing such damage and the customer shall be subrogated to the right of recovery by the Company for the damages to the extent of such payment. The amount of reimbursement shall be the actual cost of repair to the damaged facilities including labor costs as specified in <i>VII.B.7.</i></p>	
<p><b>2. Theft</b></p> <p>The customer shall reimburse the Company for any loss through theft of facilities, apparatus, or equipment utilized to provide FIA under this tariff at the CDL or at the end user's premises. The amount of reimbursement shall be the actual cost for replacement of facilities, apparatus, or equipment lost, plus labor costs as specified in <i>VII.B.6.</i></p>	

### III. GENERAL REGULATIONS (Continued)

<p><b>3. <i>Equipment Space and Power</i></b></p> <p>Except as specified in <i>III.C.4.</i>, the customer shall furnish or arrange to have furnished to the Company at no charge, equipment space and electrical power required by the Company to provide FIA under this tariff at the points of termination of such FIA. The equipment space provided shall meet industry standard environmental conditions. The selection of ac or dc power shall be mutually agreed to by the customer and the Company. The customer shall also make necessary arrangements in order that the Company will have access to such spaces at reasonable times for installing, repairing or removing facilities of the Company.</p>	
<p><b>4. <i>Space and Power for Expanded Interconnection Service</i></b></p> <p>Where available, the Company shall make available wire center or access tandem floor space and electrical power required by the customer for the provision of Expanded Interconnection Service at charges specified in Section <i>XIX.</i></p>	
<p><b>5. <i>Availability for Testing</i></b></p> <p>The FIA provided under this tariff shall be available to the Company at times mutually agreed upon in order to permit the Company to make tests and adjustments appropriate for maintaining the FIA in satisfactory operating condition. Such tests and adjustments shall be completed within a reasonable time. No credit will be allowed for any interruptions involved during such tests and adjustments.</p>	
<p><b>6. <i>Balance</i></b></p> <p>All signals for transmission over the FIA provided under this tariff shall be delivered by the customer balanced to ground except for ground start and duplex (DX), McCulloh-loop (alarm system) type signaling, and dc telegraph transmission at speeds of 75 baud or less.</p>	
<p><b>7. <i>Design of Customer Services</i></b></p> <p>Subject to the provisions of <i>III.A.7.</i>, the customer shall be solely responsible at its expense for the overall design of its services. The customer shall be responsible at its own expense, for any redesigning or rearrangement of its services which may be required because of changes in FIA, operations or procedures of the Company, minimum network protection criteria or operating or maintenance characteristics of the FIA.</p>	
<p><b>8. <i>References to the Company</i></b></p> <p>The customer may advise its end users that certain FIA are provided by the Company in connection with the service the customer furnishes to its end user; however, the customer shall not represent that the Company jointly participates in the customer's services.</p>	



### III. GENERAL REGULATIONS (Continued)

<p>9. <i>Claims and Demands for Damages</i></p> <p>a. With respect to claims of patent infringement made by third persons, the customer shall defend, indemnify, protect and save harmless the Company from and against all claims arising out of the combining with, or use in connection with, the FIA provided under this tariff, any circuit, apparatus, system or method provided by the customer, the customer or its end users.</p>	
<p>b. The customer shall defend, indemnify and save harmless the Company from and against suits, claims, and demands by third persons arising out of the construction, installation, operation, maintenance, or removal of the customer's circuits, facilities, or equipment connected to the Company's FIA provided under this tariff including, without limitation, Workmen's Compensation claims, actions for infringement of copyright and/or unauthorized use of program material, libel and slander actions based on the content of communications transmitted over the customer's circuits, facilities or equipment, and proceedings to recover taxes, fines, or penalties for failure of the customer to obtain or maintain in effect any necessary certificates, permits, licenses or other authority to acquire or operate the FIA provided under this tariff; provided, however, the foregoing indemnification shall not apply to suits, claims, and demands to recover damages for damage to property, death, or personal injury unless such suits, claims or demands are based on the tortuous conduct of the customer, its officers, agents or employees.</p>	
<p>10. <i>Coordination with Respect to Network Contingencies</i></p> <p>The customer shall, in cooperation with the Company, coordinate in planning the actions to be taken to maintain maximum network capability following natural or man-made disasters which affect telecommunications services.</p>	
<p>11. <i>Identification and Rating of VoIP-PSTN Traffic</i></p> <p>a. Scope</p> <p>(1) VoIP-PSTN Traffic is defined as traffic exchanged between the Telephone Company end user and the customer in time division multiplexing ("TDM") format that originates and/or terminates in Internet protocol ("IP") format. This section governs the identification of VoIP-PSTN Traffic that is required to be compensated at interstate access rates by the Federal Communications Commission in WC Docket No 10-90, Report and Order FCC-11-161. Specifically, this section establishes the method of separating such traffic (referred to in this tariff as "Relevant VoIP-PSTN Traffic") from the customer's traditional intrastate access traffic, so that such Relevant VoIP-PSTN Traffic can be billed in accordance with the order.</p>	
<p>The Company's interstate access rates are filled in its FCC Tariff: ZiPLY Fiber FCC TARIFF NO. 2.</p>	
<p>The FCC The FCC Tariff may be accessed on the internet at the following url: <a href="http://www.ziPLYfiber.com/tariffs">www.ziPLYfiber.com/tariffs</a>.</p>	
<p>(2) This section will be applied to the billing of switched access charges to a customer that is a local exchange carrier only to the extent that the customer has also implemented billing of interstate access charges for Relevant VoIP-PSTN Traffic in accordance with the order.</p>	

### III. GENERAL REGULATIONS (Continued)

<p>b. Rating of VoIP-PSTN Traffic</p> <p>The Relevant VoIP-PSTN Traffic identified in accordance with this tariff section will be billed at rates equal to the Telephone Company's applicable tariffed interstate switched access rates as specified in the Telephone Company's applicable Federal Access Tariff.</p>	
<p>As of July 13, 2012, any intrastate originating Toll VOIP-PSTN Traffic will be billed at rates equal to the Company's intrastate originating switched access rates as provided in this tariff. Beginning July 1, 2014, any intrastate originating Toll VOIP-PSTN Traffic identified in accordance with this tariff section will be billed at rates equal to the Telephone Company's relevant interstate switched access rates as provided in the Telephone Company's applicable Federal Access Tariff.</p>	
<p>c. Calculation and Application of Percent-VoIP-Usage Factor</p> <p>The Telephone Company will determine the number of Relevant VoIP-PSTN Traffic minutes of use ("MOU") to which interstate rates will be applied under subsection <i>b.</i>, above, by applying a Percent VoIP Usage ("PVU") factor to the total intrastate access MOU exchanges with the Telephone Company from the customer. The PVU will be derived and applied as follows:</p> <p>(1) The customer will calculate and furnish to the Telephone Company a factor (the "PVU") representing the percentage of the total intrastate and interstate access MOU that the customer exchanges with the Telephone Company in the State, that is sent to the Telephone Company and that originated in IP format; or is received from the Telephone Company and terminated in IP format. This PVU shall be based on information such as traffic studies, actual call detail, or other relevant and verifiable information.</p>	
<p>(2) The Telephone Company will, likewise, calculate a factor (the "PVU-T") representing the percentage of the Telephone Company's total intrastate access MOU in the State that the Telephone Company originates or terminates on its network in IP format. This PVU-T shall be based on information, such as the number of the Telephone Company's retail VoIP subscriptions in the state, traffic studies, actual call detail, or other relevant and verifiable information.</p>	
<p>(3) The Telephone Company will use the PVU-C and PVU-T factors to calculate a PVU factor that represents the percentage of total intrastate MOU exchanged between a Telephone Company end user and the customer that is originated or terminated in IP format, whether at the Telephone Company's end, at the customer's end, or at both ends. The PVU factor will be calculated as the sum of: 1.) the PVU-C factor and 2.) the PVU-T factor times (1.0 minus the PVU-C factor).</p>	
<p>(4) The Telephone Company will apply the PVU factor to the total terminating intrastate access MOU received from the customer to determine the number of Relevant VoIP-PSTN Traffic MOUs.</p>	
<p>(5) If the customer does not furnish the Telephone Company with a PVU pursuant to the preceding paragraph (1), the Telephone Company will utilize a PVU equal to zero (0).</p>	

### III. GENERAL REGULATIONS (Continued)

<p>d. Initial PVU Factor</p> <p>If the PVU factor is not available and/or cannot be implemented in the Telephone Company's billing systems by January 11, 2012, once the factor is available and can be implemented the Telephone Company will adjust the customer's bills to reflect the PVU retroactively to January 11, 2012. This retroactive adjustment will be made to January 11, 2012, provided that the customer provides the factor to the Telephone Company no later than April 15, 2012; otherwise, it will set the initial PVU equal to zero (0), as specified in subsection c.(1), above.</p>	
<p>e. PVU Factor Updates</p> <p>The customer may update the PVU factor quarterly using the method set forth in subsection c.(1), above. If the customer chooses to submit such updates, it shall forward to the Telephone Company, no later than fifteen (15) days after the first day of January, April, July and/or October of each year, a revised PVU factor based on data for the prior three months, ending the last day of December, March, June and September, respectively. The revised PVU factor will apply prospectively and serve as the basis for billing until superseded by a new PVU.</p>	
<p>f. PVU Factor Verification</p> <p>Not more than four (4) times in any year, the Telephone Company may ask the customer to verify the PVU factor furnished to the Telephone Company. The party so requested shall comply, and shall reasonably provide the records and other information used to determine the PVU factors.</p>	
<p><b>D. <u>Payment Arrangements and Credit Allowances</u></b></p>	
<p><b>1. <i>Payment of Charges and Deposits</i></b></p>	
<p>a. The Company may, in order to safeguard its interests, require a customer, which has a proven history of late payments to the Company or does not have established credit, to make a deposit prior to or at any time after the provision of the FIA to the customer to be held by the Company as a guarantee of the payment of rates and charges. No such deposit will be required of a customer which is a successor of a company which has established credit and has no history of late payments to the Company.</p>	
<p>A deposit may not exceed the actual or estimated rates and charges for the FIA for a two month period. The fact that a deposit has been made in no way relieves the customer from complying with the Company's regulations as to the prompt payment of bills.</p>	
<p>At such time as the provision of the FIA to the customer is terminated, the amount of the deposit will be credited to the customer's account and any credit balance which may remain will be refunded. After the customer has established a one year prompt payment record, such a deposit will be refunded or credited to the customer account at any time prior to the termination of the provision of the FIA to the customer.</p>	
<p>In case of a cash deposit, for the period the deposit is held by the Company, the customer will receive simple annual interest at the percentage rate specified in the Company's Local Tariff.</p>	

### III. GENERAL REGULATIONS (Continued)

<p>b. Where the provision of FIA requires facilities that meet any of the conditions specified in <i>XI.A.1.</i>, Special Construction charges as set forth in Section <i>XI.</i> will apply.</p>	
<p>c. The Company shall bill FIA services on a current basis for a.) all charges incurred, b.) applicable taxes, and c.) credits due the customer.</p> <p>(1) Switched Access, Ancillary and Miscellaneous services shall be billed in arrears.</p>	
<p>(2) Special Access and monthly EIS elements shall be billed in advance except for the charges and credits associated with the initial or final bills. The initial bill will also include charges for the actual period of service up to, but not including, the bill date. The unused portion of the FIA already billed will be credited on the final bill.</p>	
<p>The customer will receive its bill in: a.) a paper format, b.) a paper format bill summary with a magnetic tape to provide the detailed information of the bill, c.) magnetic tape only, or d.) via electronic transmission. Such bills are due when rendered. Adjustments for the quantities of FIA established or discontinued in any billing period beyond the minimum period set forth in <i>III.D.2.</i> will be prorated to the number of days based on a thirty (30) day month. The Company will, upon request and if available, furnish such detailed information as may reasonably be required for verification of any bill.</p>	
<p>d. All bills to the customer are due thirty-one (31) days (payment date) after the bill date or by the next bill date (i.e., same date in the following month as the bill date), whichever is the shortest interval, except bills to government entity customers.. In the event the customer does not remit payment in immediately available funds by the payment date, the FIA may be discontinued as specified in <i>III.A.8.</i></p> <p>(1) If the entire amount billed, excluding any amount disputed by the customer, is not received by the Company in immediately available funds by the payment date, an additional charge equal to 1/12th of the percentage rate for deposit interest as that set forth in <i>III.D.1.a.</i> of the unpaid balance will be applied for each month or portion thereof that an outstanding balance remains.</p>	
<p>If such payment date would cause payment to be due on a Saturday, Sunday or Holiday (i.e., New Year's Day, Independence Day, Labor Day, Thanksgiving Day, Christmas Day, the second Tuesday in November and a day when Washington's Birthday, Memorial Day or Columbus Day is legally observed), payment for such bills will be due from the customer as follows:</p>	
<p>If such If such payment date falls on a Saturday or on a Holiday which is observed on Tuesday, Wednesday, Thursday or Friday, the payment date shall be the last non-Holiday day preceding such Saturday or Holiday.</p>	
<p>If such payment date falls on a Sunday or on a Holiday which is observed on a Monday, the payment date shall be the first non-Holiday day following such Sunday or Holiday.</p>	

### III. GENERAL REGULATIONS (Continued)

<p>(2) In the event that a billing dispute is resolved in favor of the Company, any payments withheld pending settlement of the dispute shall be subject to an additional charge equal to 1/12th of the percentage rate for deposit interest as that set forth in <i>III.D.1.a.</i>, of the amount of such disputed charges for each month or portion thereof that such charges were unpaid. If the customer who has paid the total billed amount on or before the due date disputes the billed amount within six (6) months of the bill date and the dispute is resolved in favor of the customer, a credit will be granted to the customer for both the disputed amount paid and an amount equal to the percentage rate specified in <i>III.D.1.d.(1)</i> based on this disputed amount for each month or portion thereof.</p>	
<p><b>2. Minimum Periods</b></p> <p>a. The minimum periods for which FIA are provided and for which rates and charges are applicable are set forth in <i>IV.B.4.</i></p>	
<p>b. The minimum periods for which FIA are provided and for which rates and charges are applicable for Specialized FIA or Arrangements provided on an Individual Case Basis, as set forth in Section <i>VIII.</i>, are established with the individual case filing.</p>	
<p>c. For discontinuances of FIA with a one (1) month minimum period, all applicable charges for the one month period will apply. In instances where the minimum period is greater than one (1) month, however, the charge will be the lesser of the Company's non-recoverable costs less the net salvage value for the discontinued service or the minimum period charges.</p>	
<p>d. The minimum periods for which Expanded Interconnection Services are provided and which rates and charges are applicable are in Section <i>XIX.</i></p>	
<p><b>3. Cancellation of an ASR</b></p> <p>Provisions for the cancellation of an ASR are set forth in <i>IV.B.6.</i> for an ASR.</p>	
<p><b>4. Credit Allowance for FIA Interruptions</b></p> <p>a. General</p> <p>A FIA is interrupted when it becomes unusable to the customer because of a failure of a component used to furnish FIA under this tariff, or when the service was preempted as a result of invoking NSEP treatment, or when the application of protective controls interrupt all transmission paths as set forth in Section <i>V.</i> A credit allowance will be made for the period in excess of thirty (30) minutes the FIA is interrupted. An interruption period starts when Company personnel become aware that the FIA is inoperative.</p>	
<p>The credit allowance(s) for an interruption or a series of interruptions will be based upon the billing method, which applies to the service being credited. In no case will the credit allowance for interruptions exceed the applicable charges for the billing period during which the interruption occurred.</p>	

### III. GENERAL REGULATIONS (Continued)

<p>A credit allowance for any FIA service will apply for the period specified as follows:</p> <p>(1) For Special Access services other than Program Audio, Videoband and Expanded Interconnection, a credit allowance will be made for an interruption period of thirty (30) minutes or more. The allowance will be calculated at the rate of 1/1440 of the monthly charge for the portion of the FIA affected, for each thirty (30) minutes or major fraction thereof that the interruption continues. A major fraction is considered to be sixteen (16) minutes or more beyond the thirty (30) minute period.</p>	
<p>(2) For Program Audio services and Videoband Special Access, a credit allowance will be made for an interruption of thirty (30) seconds or more. Two (2) or more such interruptions occurring during a period of five (5) consecutive minutes shall be considered as one interruption. The allowance will be calculated as follows:</p> <p>(a) For Program Audio service provided at monthly rates, the credit will be at the rate of 1/8640 of the monthly service rate.</p>	
<p>(b) For Program Audio service provided at daily rates, the credit will be at the rate of 1/288 of the daily rate.</p>	
<p>(c) For Temporary Videoband Service provided at hourly rates, the credit will be at 1/12 of the hourly rate.</p>	
<p>(3) For Switched Access service, billed using assumed minutes of use, a credit allowance will be made for an interruption of twenty-four (24) hours or more. The credit allowance will be calculated at 1/30 of the assumed minutes of use charge for each twenty-four (24) hours or major fraction thereof that the interruption continues. A major fraction is considered to be thirteen (13) hours. No credit will be given where Switched Access billing is based on actual usage.</p>	
<p>b. When Credit Allowance Does Not Apply</p> <p>No credit allowance will be made for:</p> <p>(1) Interruptions caused by the negligence of the customer.</p>	
<p>(2) Interruptions of a FIA due to the failure of equipment or systems provided by the customer or others.</p>	
<p>(3) Interruptions of a FIA during any period in which the Company is not afforded access to the premises where the FIA is terminated.</p>	
<p>(4) Interruptions of a FIA during an agreed upon period when the customer has released a FIA to the Company for maintenance purposes, to make rearrangements, or for the implementation of an ASR for a change in the FIA. Should the maintenance, rearrangement, or ASR implementation interruption period extend beyond the agreed upon period, credit allowance will apply.</p>	

### III. GENERAL REGULATIONS (Continued)

<p>(5) Interruptions of a FIA which continue because of the failure of the customer to authorize replacement of any element of Special Construction, as set forth in Section XI. The period for which no credit allowance is made begins on the seventh day after the Company's written notification to the customer of the need for such replacement and ends on the day after receipt of the customer's written authorization for such replacement.</p>	
<p>(6) Periods when the customer elects not to release the FIA for testing and/or repair and continues to use it on an impaired basis.</p>	
<p>(7) Periods when the Company must temporarily interrupt an EIS, as defined in Section XIX., in order to prevent damage or disruption of the Company's network due to the customer's equipment.</p>	
<p>(8) An interruption or a group of interruptions, resulting from a common cause, for amounts less than one dollar (\$1.00).</p>	
<p>(9) For EIS elements specified in Section XIX., no credit allowance will be made.</p>	
<p>c. Use of an Alternative Service Provided by the Company</p> <p>Should the customer elect to use an alternative service provided by the Company during the period that a FIA is interrupted, the customer must pay the tariffed rates and charges for the alternative service used.</p>	
<p>d. Temporary Surrender of a FIA</p> <p>In certain instances, the customer may be requested to surrender a FIA for purposes other than maintenance, testing or activity relating to an ASR. If the customer consents, or in the instance of preemption under NSEP treatment as set forth in Section III.A.9., a credit allowance will be granted. The credit allowance will be determined in accordance with III.D.4.a..</p>	
<p>5. <i>Termination Liability</i></p> <p>a. In the event the service is terminated by the customer prior to completion of the current term commitment period, the customer shall be liable for an early termination charge, except as noted below. The amount of the early termination charge will be twenty-five percent (25%) of the monthly recurring charge(s) (MRC) for the remainder of the term. For example:</p> $25\% \times \text{MRC} \times \# \text{ of Lines/Channels/Paths} \times \text{Remainder of Term} = \text{Termination Charge}$	
<p>b. Early termination charges will apply only to those rate elements under a term commitment period. If any rates for the service are increased during the term period, exclusive of any increase due to local, state or federal fees, taxes or surcharges, the customer may terminate the service without incurring an early termination charge.</p>	

### III. GENERAL REGULATIONS (Continued)

<p>c. End of Term Options</p> <p>(1) Prior to the end of the term commitment period, the customer may select one of the following options, to be effective at the end of the term:</p> <p>(a) Renew their term commitment,</p>	
<p>(b) Commit to a new term period,</p>	
<p>(c) Arrange for a change of service, or</p>	
<p>(d) Arrange for termination of the service.</p>	
<p>(2) In the event the customer does not select one of the above options, the customer will be converted to the shortest-term period available under tariff (i.e., month-to-month, one (1) year, etc.) for the same service, and will be subject to the applicable term commitment, if any, unless the customer terminates the service within sixty (60) days of the conversion date.</p>	
<p>d. Early termination charges will not be assessed under the following circumstances:</p>	
<p>(1) Customer moves existing service either to a new location within the same address and/or same building (inside move) or to a new location (outside move) and maintains that service for the remainder of the term;</p>	
<p>(2) Customer attempts to move the existing service to a new location within the Company's service area, but the service is unavailable;</p>	
<p>(3) Customer renegotiates a new term commitment plan for the same service before the current term commitment expires and the value of the new term commitment is equal to or greater than the remaining value of the current term commitment; or</p>	
<p>(4) Customer changes to another service or upgrades service to a higher speed or capacity under a term commitment, provided the following conditions are met:</p> <p>(a) The value of the new term commitment is equal to or greater than the remaining value of the current term commitment,</p>	
<p>(b) The Company provides the new service via tariff or on an individual case basis (ICB), and</p>	
<p>(c) The order to discontinue the existing service and the order for the new or upgraded service are received by the Company at the same time.</p>	



### III. GENERAL REGULATIONS (Continued)

<p><b>E. <u>Connections</u></b></p> <p>1. <i>General</i></p> <p>Equipment and systems (i.e., terminal equipment, multiline terminating systems, and communication systems) may be connected with Switched and Special Access furnished by the Company where such connection or interconnection is made in accordance with the provisions specified in <i>III.A.</i>.</p>	
<p>2. <i>Standard Access Service Connections</i></p> <p>Access services are provided by means of wire, fiber optics, or any other suitable technology or a combination thereof. Special Access service connections are made directly or through a Company hub where bridging or multiplexing functions are performed. These connections can either be analog or digital.</p>	
<p>3. <i>Expanded Interconnection Service (EIS) – Fiber Optic</i></p> <p>Fiber Optic EIS provides a customer with space and associated requirements such as power and environmental conditioning within or near a Company wire center or access tandem to locate certain fiber optic facilities and equipment, an interconnection with certain Company provided facilities.</p>	
<p>EIS will be provided subject to the regulations and rates and charges set forth in Section <i>XIX.</i>.</p>	
<p>4. <i>Expanded Interconnection Service (EIS) – Microwave</i></p> <p>Microwave EIS provides a customer with space and associated requirements such as power and environmental conditioning within a Company wire center or access tandem to locate certain microwave facilities and equipment, and a connection to certain Company provided facilities.</p>	
<p>Customer-provided microwave facilities, equipment and support structures may be located in, on or above the exterior walls and roof of Company wire centers or access tandems. Such interconnection must be made in accordance with the provisions specified in <i>III.A.</i>. These interconnections will be provided subject to the regulations and rates and charges specified in Section <i>XIX.</i>.</p>	

### III. GENERAL REGULATIONS (Continued)

#### F. Definitions

Certain terms used herein are defined as follows:

##### Access Area

The term "Access Area" denotes a specific calling area containing those customers served by one or more Central Offices associated with the various Switched Access provisions offered under this tariff. The size and configuration of the Access Area a customer obtains is dependent upon the Feature Group type and the specific characteristics of the Central Office or Access Tandem office to which the connection is made.

##### Access Code

The term "Access Code" applies to Switched Access Service. It denotes a uniform five (5) or seven (7) digit code dialed by an end user to access an Interexchange Carrier's facilities. The seven (7) digit FGD code has the form of 101XXXX and the seven (7) digit FGB code has the form of 950-XXXX.

##### Access Minutes

The term "Access Minutes" denotes that usage of exchange facilities in intrastate service for the purpose of calculating chargeable usage. On the originating end of an intrastate call, usage is measured from the time the originating End User's call is delivered by the Company to and acknowledged as received by the customer's facilities connected with the originating exchange. On the terminating end of an intrastate call, usage is measured from the time the call is received by the End User in the terminating exchange. Timing of usage at both originating and terminating ends of an intrastate call shall terminate when the calling or called party disconnects, whichever event is recognized first in the originating and terminating end exchanges, as applicable. For the calculation of total minutes, seconds are totaled and converted to minutes before rounding occurs. Remainder seconds greater than twenty-nine (29) are rounded to a minute.

##### Access Service Request

The term "Access Service Request" (ASR) denotes a document (i.e., order) used by the Company to process a customer's request for Access Services as offered throughout this tariff.

##### Access Tandem

The term "Access Tandem" denotes a telephone company switching system that provides a traffic concentration and distribution function for traffic originating from or terminating at end offices in the access area.

##### Answer/Disconnect Supervision

The term "Answer/Disconnect Supervision" denotes the transmission of the switch trunk equipment supervisory signal (off-hook or on-hook) to the CDL for terminating calls to a Company end office as an indication that the called party has answered or disconnected.

*Continued on next page...*

### III. GENERAL REGULATIONS (Continued)

*Continued from previous page...*

#### Answer Message

The term "Answer Message" denotes an SS7 message sent in the backward direction to indicate that the call has been answered.

#### Attempt

The term "Attempt" denotes a call in the originating direction from an end user to a CDL which is completed (answered) or not completed (not answered) and a call in the terminating direction from a CDL to a customer which is completed (answered) or not completed (not answered).

#### Attenuation Distortion

The term "Attenuation Distortion" denotes the difference in loss at specified frequencies relative to the loss at 1004 Hz.

#### Balance (100-Type) Test Line

The term "Balance (100-Type) Test Line" denotes a standard feature of FGA, FGB, FGC, FGD, and 800/877/888 Access Service and refers to the end office termination provided for balance and noise testing. The termination provides off-hook supervision to the calling end, and terminates the line or trunk in a resistive and capacitive arrangement which simulates the characteristic impedance of the end office.

#### Basic Service Element

The term "Basic Service Element (BSE)" denotes an unbundled service option available only with Basic Serving Arrangements.

#### Basic Serving Arrangement

The term "Basic Serving Arrangement (BSA)" denotes a category of Switched Access Service differentiated by technical characteristics, e.g., line side versus trunk side connection at the Company's first point of switching.

#### BHMC

See Busy Hour Minutes of Capacity.

#### Bit

The term "Bit" denotes a binary digit, the smallest unit of information in the binary system of notation.

#### Bridging

The term "Bridging" denotes the connection of one or more circuits in parallel with another circuit without interrupting the continuity of the first circuit.

*Continued on next page...*

### III. GENERAL REGULATIONS (Continued)

*Continued from previous page...*

#### Bridging Wire Center

The term "Bridging Wire Center" denotes the Company designated wire center in which bridging is accomplished.

#### Burst Rate

The term "Burst Rate" denotes the upper bandwidth limit the Permanent Virtual Circuit (PVC) is allowed to send data through the Frame Relay Service (FRS) Network. The burst rate is limited by the actual physical port access speed.

#### Business Day

The term "Business Day" denotes the times of day that a company is open for business. Generally, in the business community, these are 8:00 or 9:00 AM to 5:00 or 6:00 PM, respectively, with an hour for lunch, Monday through Friday, resulting in a standard forty (40) hour work week.

#### Busy Hour Minutes of Capacity

The term "Busy Hour Minutes of Capacity" (BHMC) denotes the trunk group usage load consisting of the average usage load for the busy season.

#### Busy Season

The term "Busy Season" denotes the four consecutive weeks of the calendar year having the highest daily busiest hour traffic load based on a five (5) day week. Normally the five (5) day week consists of Monday through Friday. Where weekend traffic is greater than weekday traffic, one or both weekend days may be used as a substitute for a weekday as long as a consistent five (5) day week is maintained for the four (4) consecutive weeks.

#### Byte

The term "Byte" denotes a sequence or group of eight bits that represent one character.

#### C-Conditioning

The term "C-Conditioning" denotes a Company special treatment of the transmission path in order to control attenuation and envelope delay distortion.

#### C-Message Noise

The term "C-Message Noise" denotes the frequency weighted average noise within an idle voice circuit. The frequency weighting, called C-message, is used to simulate the frequency characteristic of the 500-type telephone set and the hearing of the average subscriber.

*Continued on next page...*

### III. GENERAL REGULATIONS (Continued)

*Continued from previous page...*

#### C-Notched Noise

The term "C-Notched Noise" denotes the frequency weighted noise on a voice circuit with a holding tone, which is removed at the measuring end through a notch (very narrow band) filter.

#### CCS

The term "CCS" denotes a hundred-call seconds which is a standard unit of traffic load that is equal to one hundred (100) seconds of usage or capacity of a group of lines or trunks.

#### Call

The term "Call" denotes a communication including an off-hook signal and routing information initiated at the originating location and completed to a terminating location.

#### Carrier Identification Parameter

The term "Carrier Identification Parameter" (CIP) denotes a field in the SS7 Initial Address Message (IAM) that identifies and transmits CIC information in a forward direction to an IC customer.

#### Central Office

The term "Central Office" denotes a telephone company local switching system where telephone company local service subscriber station loops are terminated for purposes of interconnection to each other and to trunks.

#### Central Office Loop Around Test Line

The term "Central Office Loop Around Test Line" denotes equipment in the Company's end office which provides a means for making two-way transmission tests for Switched Access services. These transmission tests are normally for the measurement of level and noise tests. This arrangement has two (2) terminations, each reached by means of a separate seven (7) digit number.

#### Central Office Prefix

The term "Central Office Prefix" denotes the first three (3) digits (NXX) of the telephone number assigned to a Company subscriber's local service.

#### Centralized Automatic Reporting on Trunks (CAROT) Testing

The term "Centralized Automatic Reporting on Trunks (CAROT) Testing" denotes a type of testing which includes the capacity for measuring the 1000 Hz loss, C-message weighted noise, C-notched noise, loss slope, and the provision of a balance termination.

*Continued on next page...*

### III. GENERAL REGULATIONS (Continued)

*Continued from previous page...*

#### Channelize

The term "Channelize" denotes the process of multiplexing demultiplexing circuits using analog or digital techniques.

#### Circuit

The term "Circuit" denotes an electrical or photonic, in the case of fiber optic based transmission systems, communications path between two (2) or more points of termination.

#### Circuit Code

The term "Circuit Code" denotes the service class routing of an SS7 call that indicates the interexchange carrier trunk group to which the traffic will be routed (e.g., 0+, 0-, 500, 900, etc.).

#### Circuit Switched Line

The term "Circuit Switched Line" denotes the generic name used by the Information Industry Liaison Committee (IILC) for Feature Group A (FGA) or Unbundled Feature Group A (BSA-A) service, which provides a line-side connection to the circuit switched network. Detailed descriptions for FGA and BSA-A are found in Section V..

#### Circuit Switched Trunk

The term "Circuit Switched Trunk" denotes the generic name used by the Information Industry Liaison Committee (IILC) for Feature Group B (FGB), Feature Group C (FGC), Feature Group D (FGD), Unbundled Feature Group B (BSA-B), Unbundled Feature Group C (BSA-C) and Unbundled Feature Group D (BSA-D) service, which provides a trunk-side connection to the circuit switched network. Detailed descriptions are found in Section V..

#### Common Channel Signaling System 7 Network (CCS7)

The term "Common Channel Signaling System 7 Network (CCS7)" denotes a dedicated Out of Band Signaling network which utilizes Signaling System 7 (SS7) protocol to provide call handling and data base access service.

#### Common Line

The term "Common Line" denotes a line, trunk, coin line or other facility provided under the Company's Local Tariff, terminated on a Central Office switch. A Common Line provides access to: 1.) the local calling area as defined in the Local Tariff, 2.) authorized long distance carriers, and 3.) service codes (e.g., 411, 611, 911). A Common Line -Residence is a line or trunk provided under the residence regulations of the Local Tariff. A Common Line - Business is a line provided under the business regulations of the Local Tariff. A coin line is a line provided under the public and/or semi-public service regulations of the Local Tariff.

*Continued on next page...*

### III. GENERAL REGULATIONS (Continued)

*Continued from previous page...*

#### Communications System

The term "Communications System" denotes circuits and other facilities which are capable of communications between terminal equipment provided by other than the Company or Company stations.

#### Confirmed Access Service Request (ASR)

The term "Confirmed Access Service Request" denotes a customer's ASR for 1.) Switched Access FIA which the Company has processed with the Engineering Department to confirm for the customer and the Company the availability of facilities and/or equipment, and 2.) Special Access FIA for which the Company confirms to the customer that the established due date can be met. The date the ASR is confirmed, the standard service date interval commences.

#### Confirming Design Layout Report Date

The term "Confirming Design Layout Report (CDLR) Date" identifies the date that the Company is scheduled to receive confirmation that the Design Layout Report provided by the Company for a confirmed ASR is acceptable.

#### Conventional Signaling

The term "Conventional Signaling" denotes the inter-machine signaling system which has been traditionally used in North America for the purpose of transmitting the called number's address digits from the originating end office to the switching machine which will terminate the call. In this system, all of the dialed digits are received by the originating switching machine, a path is selected, and the sequence of supervisory signals and outputted digits is initiated. No overlap outputting, ten (10) digit Automatic Number Identification (ANI), ANI information digits, or acknowledgement wink are included in this signaling sequence.

#### Customer

The term "Customer" denotes any individual, partnership, association, joint stock company, trust, corporation, or governmental entity or any other entity which subscribes to the services offered under this tariff.

#### Customer Designated Location

The term "Customer Designated Location" (CDL) denotes a location specified by the customer for the purpose of terminating FIA services. The Company must have access to the location to perform installation, testing, and maintenance functions. The customer may or may not have access to the location. CDLs include locations such as customer premises, end user premises, customer repeater stations, customer microwave towers, a Company's first point of switching, some other point where Company testing can occur, etc. A CDL may be designated by the customer for Switched Access, Special Access, or both in combination.

*Continued on next page...*

### III. GENERAL REGULATIONS (Continued)

*Continued from previous page...*

#### D-Conditioning

The term "D-Conditioning" denotes a Company special treatment of the transmission path in order to control C-notched noise and intermodulation distortion.

#### Daily Busiest Hour

The term "Daily Busiest Hour" denotes the highest usage hour for each day with the reading taken on the clock hour or half hour. The clock hour or half hour selection varies from day to day, depending upon the usage measured. The Daily Busiest Hour is also known as the Bouncing Busy Hour.

#### Data Transmission (107-Type) Test Line

The term "Data Transmission (107-Type) Test Line" denotes an arrangement which provides for the connection to a signal source which provides test signals for one-way testing of data and voice transmission parameters.

#### Dual Tone Multifrequency Address Signaling

The term "Dual Tone Multifrequency (DTMF) Address Signaling" denotes a type of signaling that is an optional feature of FGA and BSA-A. It may be utilized when FGA or BSA-A is being used in the terminating direction. An office arranged for signaling would expect to receive address signals from the IC in the form of DTMF format.

#### Echo Path Loss

The term "Echo Path Loss" denotes the measure of reflected signal at a four-wire interface without regard to the send and receive Transmission Level Point (TLP).

#### Echo Return Loss

The term "Echo Return Loss" denotes a frequency weighted measure of return loss over the middle of the voiceband (approximately 500 to 2500 Hz) where talker echo is most annoying.

#### End Office Switch

The term "End Office Switch" denotes a Company local switching system located in a wire center where Company local service subscriber station loops are terminated for purposes of originating and terminating traffic to or from a customer.

*Continued on next page...*



### III. GENERAL REGULATIONS (Continued)

*Continued from previous page...*

#### End User

The term "End User" means any customer of an intrastate telecommunications service that is not a carrier, except that a carrier, other than the Company, shall be deemed to be an "end user to the extent that such carrier uses a telecommunications service for administrative purposes, and a person or entity that offers telecommunications services exclusively as a reseller shall be deemed to be an "end user" if all resale transmissions offered by such reseller originate on the premises of such reseller (e.g., hotels, motels and shared tenant services).

#### Engineering Review

The term "Engineering Review" denotes the examination of an ASR with a customer requested change to determine if a design change is required. It includes, but is not limited to, the review for possible change requirements in equipment, interfaces, circuit configurations, engineering records, and billing.

#### Enhanced Service

The term "Enhanced Service" denotes a service which employs computer processing applications that act on the format, content, code, protocol or similar aspects of the customer's transmitted information; provides the customer with additional, different, or restructured information; or involves customer interaction with stored information. Enhanced services include but are not limited to information retrieval services, voice messaging, and protocol translation between customer equipment or software.

#### Enhanced Service Provider

The term "Enhanced Service Provider (ESP)" denotes a person which supplies enhanced services by using ONA services furnished by an Interexchange Carrier (IC), including the enhanced services operation of the Company acting as an ESP. An Interexchange Carrier acts as an ESP only when it provides enhanced services to customers separate from its provision of basic services.

#### Entry Switch

See First Point of Switching.

#### Excess Capacity

The term "Excess Capacity" denotes a quantity of FIA requested by the customer which is greater than that which the Company would construct to fulfill the customer's ASR.

#### Exchange

The term "Exchange" denotes a unit generally smaller than a Local Access and Transport Area (LATA), established by the Company for the administration of communications service in a specified area which usually embraces a city, town or village and its environs. It consists of one or more central offices together with the associated facilities used in furnishing communications service within that area. One or more designated exchanges comprise a given LATA.

*Continued on next page...*

### III. GENERAL REGULATIONS (Continued)

*Continued from previous page...*

#### Exchange Access Signaling

The term "Exchange Access Signaling" denotes the signaling system which is used, by equal access end offices, to transmit originating information and address digits to the customer's premises and which includes the means of verifying the receipt of these address digits. Features of this system include overlap outpulsing (in suitably equipped end offices), identification of the type of call, identification of the ten-digit telephone number of the calling party, and knowledge wink supervisory signals.

#### Existing Suitable Space

The term "Existing Suitable Space" denotes a space in which ac/dc power, heat and air conditioning, battery and generator backup power, and other requirements necessary for provision of wire center or access tandem equipment currently exists.

#### Exit Message

The term "Exit Message" denotes an SS7 message sent to an end office by the Company tandem switch to mark the connect time when the Company's tandem switch sends an Initial Address Message to a customer.

#### Extended Area service

The term "Extended Area Service" (EAS) denotes an arrangement whereby a customer in one exchange can call a local number in another exchange that is part of the extended area without paying a toll charge.

#### Facility

The term "Facility" denotes generically the various transmission media used for the transmission of telecommunication services. This includes, but is not limited to, cable (copper pair, coaxial, and fiber optic) and microwave radio equipment.

#### Firm Order Confirmation Date

The term "Firm Order Confirmation (FOC) Date" denotes the date that the Company will provide the schedule of dates for the provisioning activities associated with the customer's request for service.

#### First Point of Switching

The term "First Point of Switching" denotes either the first telephone company location at which switching occurs on the terminating path of a call proceeding from the CDL to the terminating end office or the last telephone company location at which switching occurs on the originating path of a call proceeding from the originating end office to the CDL.

*Continued on next page...*

### III. GENERAL REGULATIONS (Continued)

*Continued on next page...*

#### Four-Wire to Two-Wire Conversion

The term "Four-Wire to Two-Wire Conversion" denotes an arrangement which converts a four-wire transmission path to a two-wire transmission path to allow a four-wire facility to terminate in a two-wire entity such as a central office switch trunk circuit or switching system.

#### Frame

The term "Frame" denotes a group of data bits, in a specific format, with a flag at either end to indicate the beginning and end of the frame. The defined format enables network equipment to recognize the meaning and purpose of specific bits.

#### Frame Relay Port

For Frame Relay Service, the physical entry points for access lines and the originating and terminating points for Permanent Virtual Circuits (PVCs). Ports include the electronic equipment used in connecting these service elements to the Frame Relay Network, and enable customers to allocate bandwidth to application, as needed, at customer designated transmission speeds of 56 Kbps up to 1.544 Mbps.

#### Gateway Switch

The term "Gateway Switch" denotes the switch through which communication passes between public packet switched networks.

#### Ground Start Supervisory Signaling

The term "Ground Start Supervisory Signaling" denotes a type of signaling which provides for the application of ground on the tip side of the point of termination (assuming no signaling conversion has been provided by the Company) as an initial seizure signal before the application of ringing in the originating direction (towards the customer from the end office).

#### HUB

The term "HUB Wire Center" Denotes a Company designated serving wire center that is equipped to provide service.

#### Immediately Available Funds

The term "Immediately Available Funds" denotes a corporate or personal check drawn on a bank account and funds which are available for use by the receiving party on the same day on which they are received and includes U.S. Federal Reserve bank wire transfers, U.S. Federal Reserve notes (paper cash), U.S. coins, U.S. Postal Money Orders and New York Certificates of Deposit.

*Continued on next page...*

### III. GENERAL REGULATIONS (Continued)

*Continued from previous page...*

#### Individual Case Basis

The term "Individual Case Basis" (ICB) denotes a condition where the regulations, if applicable, rates and charges for an offering under the provisions of this tariff are developed based on the circumstances in each case.

#### Information Service Provider

The term "Information Service Provider" denotes one who offers a capability for generating, acquiring, storing, transforming, processing, retrieving, utilizing, or making available information which may be conveyed via telecommunications, except that such service does not include 1.) any use of any such capability for the management, control, or operation of a telecommunications system or the management of a telecommunications service, or 2.) the provision of time, weather, and such other similar audio services that are offered by local exchange companies.

#### Initial Address Message (IAM)

The term "Initial Address Message" denotes an SS7 message sent in the forward direction to trunk set up with the busy of an outgoing trunk which carries the information about that trunk along with other information relating to the routing and handling of the call to the next switch.

#### Installed Cost

The term "Installed Cost" denotes the total investment (estimated or actual) by the Company to provide facilities for the offered services.

#### Interconnection

The term "Interconnection" denotes the termination of a customer's basic transmission facilities, including optical terminating equipment and multiplexers at or near Company wire center or access tandem. Interconnection may be provided as either physical or virtual.

#### Interconnection Point

The term "Interconnection Point" denotes physical EIS arrangements as the point where the customer-owned cable facilities connect to the Company termination equipment. The interconnection point for virtual EIS arrangements is the demarcation between ownership of the cable facilities.

#### Interexchange Carrier (IC) or Interexchange Common Carrier

The terms "Interexchange Carrier" (IC) or "Interexchange Common Carrier" denote any individual, partnership, association, joint stock company, trust, governmental entity or corporation engaged for hire in intrastate, interstate or foreign communication by wire or radio, between two (2) or more LATAs.

*Continued on next page...*

### III. GENERAL REGULATIONS (Continued)

*Continued from previous page...*

#### Intermodulation Distortion

The term "Intermodulation Distortion" denotes a measure of the nonlinearity of a circuit. It is measured using four tones, and evaluating the ratios (in dBs) of the transmitted composite four-tone signal power to the second-order products of the tones (R2), and the third-order products of the tones (R3).

#### Interstate Communications

The term "Interstate Communications" denotes both interstate and foreign communications.

#### Intrastate Communications

The term "Intrastate Communications" denotes any communications within a state subject to oversight by a state regulatory commission as provided by the laws of the State of Oregon.

#### Kilosegment

The term "Kilosegment" denotes a unit of packet transmission defined as 64,000 bytes of data; one thousand segments.

#### Line

The term "Line" denotes a communications path connecting an end office switch with an end user's premises or a CDL for the provision for FGA or BSA-A.

#### Line Group

The term "Line Group" denotes a grouping of lines which are traffic engineered as a unit for the establishment of connections between end office switches and customers in which all of the communications paths are interchangeable.

#### Line Side Connection

The term "Line Side Connection" denotes a connection of a transmission path to the line side of an end office system.

#### Local Area Network (LAN)

A network permitting the interconnection and intercommunication of a group of computers, primarily for the sharing of resources such as data storage devices and printers.

#### Local Access and Transport Area

The term "Local Access and Transport Area" (LATA) denotes a geographic area for the provision and administration of communications service. It encompasses designated Access Areas which are grouped to serve common social, economic, and other purposes.

*Continued on next page...*

### III. GENERAL REGULATIONS (Continued)

*Continued from previous page...*

#### Logical Channel

The term "Logical Channel" denotes a communication channel which allows two-way simultaneous transmission of data packets through the Network. No circuit capability is preassigned to a logical channel. Capacity is made available as the data is transmitted. Each virtual connection utilizes one logical channel.

#### Maximum Burst Size

The term "Maximum Burst Size" (MBS) denotes the consecutive number of Asynchronous Transfer Mode (ATM) cells that can enter the ATM Cell Relay Service (CRS) network above the Sustained Cell Rate level and below the Peak Cell Rate level.

#### Maximum Termination Liability

The term "Maximum Termination Liability" (MTL) denotes the maximum amount of money for which the customer is liable in the event all FIA ordered in a Special Construction case are discontinued before a specified period of time.

#### Maximum Termination Liability Period

The term "Maximum Termination Liability Period" denotes the length of time the customer is liable for a termination charge in the event specially constructed FIA are terminated. The MTL period is equal to the average account life of the FIA provided.

#### Mid Link

The term "Mid Link" denotes the Special Transport facilities between Hub Wire Centers where the circuit is bridged and/or where switching devices such as a loop transfer arrangement are located.

#### Milliwatt (102 Type) Test Line

The term "Milliwatt (102-Type) Test Line" denotes an arrangement in an end office which provides a 1004 Hz tone at 0 dBm0 for one-way transmission measurements towards the CDL from the Company end office.

#### Mobile Telephone Switching Office (MTSO)

The term "Mobile Telephone Switching Office (MTSO)" denotes a Cellular Mobile Carrier (CMC) switching facility that is used to originate or terminate calls on the CMC network, or originate or terminate calls between the CMC and the public switched telephone network.

*Continued on next page...*

### III. GENERAL REGULATIONS (Continued)

*Continued from previous page...*

#### Multicarrier Access Area

The term "Multicarrier Access Area" denotes an EAS for FGA and BSA-A or an area for FGB and BSA-B where FIA Services are provided by more than one (1) telephone company in which a customer obtains access to an entire EAS or FGB or BSA-B area by obtaining a FGA or FGB or BSA-B access tandem arrangement that connects its switch with the First Point of Switching of the Primary Exchange Carrier.

#### National Security Emergency Preparedness (NSEP) Services

The term "National Security Emergency Preparedness (NSEP) Services" denotes telecommunications services which are used to maintain a state of readiness or to respond to and manage any event or crisis (local, national or international), which causes or could cause injury or harm to the population, damage to or loss of property, or degrades or threatens the NSEP posture of the United States.

#### Net Salvage

The term "Net Salvage" denotes the estimated scrap, sale, or trade-in value, less the estimated cost of removal. Cost of removal includes the costs of demolishing, tearing down, removing, or otherwise disposing of the material and any other applicable costs. Because the cost of removal may exceed salvage, facilities may have negative net salvage.

#### Network Address

The term "Network Address" denotes the alphanumeric character string used to specify the destination of each switched connection made within the network.

#### Network Channel Interface Code

The "Network Channel Interface" code (NCI) is an ordering code that provides an indication of the generic channel type. The NCI code provides the technical characteristics of the interface and describes the physical and electrical characteristics of the special access interface to the CDLs.

#### Non Overlap Outpulsing

The term "Non-Overlap Outpulsing" is the feature of the exchange access signaling system which provides initiation of pulsing to the customer's premises after the calling subscriber has completed dialing an originating call.

#### Nonrecoverable Cost

The term "Nonrecoverable Cost" denotes the cost of specially constructed facilities for which the Company has no foreseeable use should the customer terminate service.

*Continued on next page...*

### III. GENERAL REGULATIONS (Continued)

*Continued from previous page...*

#### Nonsynchronous Test Line

The term "Nonsynchronous Test Line" denotes an arrangement in step-by-step end offices which provides operational tests which are not as complete as those provided by the synchronous test lines, but which can be made more rapidly.

#### North American Numbering Plan

The term "North American Numbering Plan" denotes a three (3) digit area or Numbering Plan Area (NPA) code and a seven (7) digit telephone number made up of a three (3) digit Central Office code (NXX) plus a four (4) digit station number (XXXX).

#### NSEP Treatment

The term "NSEP Treatment" denotes the provisioning of a telecommunications service before others based on the provisioning priority level assigned by the Executive Office of the President.

#### Octet

The term "Octet" denotes a group of eight (8) binary digits operated upon as an entity.

#### Off-Hook

The term "Off-Hook" denotes the active condition of Switched Access or a Company local service line.

#### On-Hook

The term "On-Hook" denotes the idle condition of Switched Access or a Company local service line.

#### Open Circuit Test Line

The term "Open Circuit Test Line" denotes an arrangement in an end office which provides an ac open circuit termination of the trunk or line by means of an inductor of several Henries.

#### Operator Services Switching Location (OSSL)

A Company office where Company equipment processes Operator Service calls to or from a customer designated location in the same LATA.

#### Order Interval

The term "Order Interval" denotes the interval between the Scheduled Issue Date and the Service Date.

*Continued on next page...*



### III. GENERAL REGULATIONS (Continued)

*Continued from previous page...*

#### Originating Direction

The term "Originating Direction" denotes the use of Switched Access for the origination of calls from an end user to a CDL.

#### Overlap Outpulsing

The term "Overlap Outpulsing" is the feature of the exchange access signaling system which permits initiation of pulsing to the customer's premises before the calling subscriber has completed dialing an originating call.

#### Packet

The term "Packet" denotes a continuous sequence of binary digits of information which is switched through the network as an integral unit. The user data is divided into segments for billing purposes. The number of segments contained in a packet is dependent upon the packet size.

#### Packet Switch

The term "Packet Switch" denotes a central office based switch that establishes a virtual connection between two data network addresses for the transmission of discrete amounts of information.

#### Packet Switching Office

The term "Packet Switching Office" denotes the central office where the packet switching functions are performed and access to the packet network is accomplished.

#### Permanent Virtual Circuit

The term "Permanent Virtual Circuit" denotes a logical channel, defined in software, from one end user location to another. It allows a packet to be sent over a dedicated logical channel without call set up or clearing.

#### Physical EIS

The term "Physical EIS" denotes an offering that enables customers to place equipment needed to terminate basic transmission facilities, including optical terminating equipment and multiplexers, within or upon the Company's wire center or access tandem buildings, to use such equipment to connect customer's fiber optic systems or microwave radio transmission facilities (where reasonably feasible) with the local exchange carrier's equipment and facilities used to provide intrastate switched and special access services.

#### Plant Test Date

The term "Plant Test Date" denotes the date on which installation is completed and the Company to customer testing can begin.

*Continued on next page...*

### III. GENERAL REGULATIONS (Continued)

*Continued from previous page...*

#### Point of Termination

The term "Point of Termination" denotes the point of demarcation at a CDL or end user premises at which the Company's responsibility for the provision of FIA Service ends.

#### Port

The term "Port" denotes a communications interface through which a customer or user sends data packets. Ports are the physical entry points for Access Lines. Ports include the electronic equipment used in connecting elements to the network.

#### Premises

The term "Premises" denotes a building or buildings on continuous property (except Railroad Right-of-Way, etc.) not separated by a public highway.

#### Pre-service Testing

The term "Pre-service Testing" denotes tests performed on a FIA to assure standard transmission performance/parameters meet specifications prior to acceptance testing.

#### Primary Exchange Carrier

The term "Primary Exchange Carrier" (PEC) denotes the telephone company in whose exchange a customer's first point of switching (i.e., dial tone for FGA or BSA-A, an access tandem for FGB or BSA-B) is located.

#### Protocol

The term "Protocol" denotes a set of rules governing the format to be followed when transmitting information between communicating devices.

#### Public Pay Telephone

The term "Public Pay Telephone" denotes a switched coin line provided under the Public Telephone Service regulations of the Company's Local Tariff.

#### Query

The term "Query" denotes a Signaling System 7 (SS7) message requesting specific information from a data base.

#### Recoverable Cost

The term "Recoverable Cost" denotes the cost of specially constructed facilities for which the Company has a foreseeable reuse, either in place or elsewhere should the customer terminate service.

*Continued on next page...*

### III. GENERAL REGULATIONS (Continued)

*Continued from previous page...*

#### Registered Equipment

The term "Registered Equipment" denotes the customer's terminal equipment which complies with or has been approved within the Registration Provisions of 47 CFR § 68.1 et al.

#### Release Message

The term "Release Message" denotes an SS7 Message sent either direction to indicate that a specific circuit is being release.

#### Response

The term "Response" denotes an SS7 message representing a reply to a request for information contained in a query.

#### Scheduled Issue Date

The term "Scheduled Issue Date" denotes the date the Company is scheduled to issue the confirmed ASR to all associated work groups.

#### Secondary Exchange Carrier

The term "Secondary Exchange Carrier" (SEC) denotes the telephone company in whose exchange a customer does not subscribe to FGA or BSA-A, or FGB or BSA-B service, but from whose exchange the customer's end users can call the interexchange switch or CDL of an IC in the primary exchange of another telephone company on a toll-free basis.

#### Segment

The term "Segment" denotes a unit of user information consisting of 64 octets or less. Billing for Packet Switching Network Service is based on the number of segments transmitted within the user data field of a packet. The number of segments transmitted within a packet is limited only by the subscribed or negotiated maximum size of the user data field for the customer interface.

#### Semi-Public Pay Telephone

The term "Semi-Public Pay Telephone" denotes a switched coin line provided under the Semi-Public Telephone Service regulations of the Company Local Tariffs.

#### Service Control Point (SCP)

The term "Service Control Point (SCP)" denotes an SS7 network control interface element between the Company's SS7 network and one or more data bases.

*Continued on next page...*

### III. GENERAL REGULATIONS (Continued)

*Continued from previous page...*

#### Service Date

The term "Service Date" denotes the date that the FIA is to be placed in service. A confirmed ASR is required to establish a service date.

#### Service Switching Point (SSP)

The term "Service Switching Point (SSP)" denotes a signal point equipped with the ability to halt call process, formulate and send a SS7 query to a remote location and route the call based on information contained in the response.

#### Seven-Digit Manual Test Line

The term "Seven-Digit Manual Test Line" denotes a set of optional features for all Switched Access which allow the IC to select balance, milliwatt, and synchronous test lines of FGA and BSA-A, by manually dialing a seven (7) digit number over the associated Switched Access.

#### Short Circuit Test Line

The term "Short Circuit Test Line" denotes the end office circuit which provides an ac short circuit termination of the trunk or line by means of a capacitor of at least four (4) microfarads.

#### Signaling Point (SP)

The term "Signaling Point (SP)" denotes an SS7 network interface element capable of originating and/or terminating SS7 messages.

#### Signaling System 7 (SS7)

The term "Signaling System 7 (SS7)" denotes the layered protocol used for standardized common channel signaling in the United States.

#### Signaling Transfer Point (STP)

The term "Signaling Transfer Point (STP)" denotes a packet switch which provides access to the Company's SS7 network and performs SS7 message signal routing and screening. The technical interface specifications, transmission specifications, and diversity requirements for interconnecting to the Company's SS7 network at the STP are as described in a Technical Reference Publication.

#### Statistical Multiplexing

The term "Statistical Multiplexing" denotes a multiplexing technique in which timeslots are dynamically allocated on the basis of need rather than being predetermined; the data is typically transmitted on a first come, first served basis.

*Continued on next page...*

### III. GENERAL REGULATIONS (Continued)

*Continued from previous page...*

#### Synchronous Test Line

The term "Synchronous Test Line" denotes an arrangement of an end office which performs marginal operational tests of supervisory and ring-tripping functions.

#### Telecommunications Service Priority (TSP) System

The term "Telecommunications Service Priority (TSP) System" or "TSP System" or "NSEP TSP System" refers to the regulatory, administrative and operational system authorizing and providing for priority treatment (i.e., the provisioning and restoration) of NSEP Services.

#### Temporary Facilities

The term "Temporary Facilities" denotes facilities used to provide FIA to a customer for less than the minimum service period or less than one month, whichever is longer, or to provide FIA while permanent facilities are being constructed.

#### Term Commitment

The length of time for which a customer agrees to pay for service, facilities or equipment. The payment period may be referred to as an Extended Service Plan (ESP), Optional Payment Plan (OPP), a Term Commitment Plan or Period (TCP), or Term Payment Plan (TPP).

#### Terminating Direction

The term "Terminating Direction" denotes the use of Switched Access for the completion of calls from a CDL to an end user.

#### Trunk

The term "Trunk" denotes a communications path connecting two switching systems in a network, used in an end-to-end connection.

#### Trunk Group

The term "Trunk Group" denotes a grouping of trunks which are traffic engineered as a unit for the establishment of connections between switching systems in which all of the communications paths are interchangeable.

#### Trunk Side Connection

The term "Trunk Side Connection" denotes the connection of a transmission path to the trunk side of an end office switch.

*Continued on next page...*

### III. GENERAL REGULATIONS (Continued)

*Continued from previous page...*

#### V&H Coordinates Method

The term "V&H Coordinates Method" denotes a method of computing airline miles between two points by utilizing an established formula which is based on the Vertical (V) and Horizontal (H) coordinates of the two points.

#### Virtual Connection

The term "Virtual Connection" denotes a logical channel resulting from call establishment to a network address that exists until the call is terminated by either party.

#### Virtual EIS

The term "Virtual EIS" denotes an offering that enables customers to designate or specify equipment needed to terminate basic transmission facilities, including optical terminating equipment and multiplexers, to be located within or upon Company' s wire center or access tandem buildings, and dedicated to such customer's use.

#### WATS Access

The term "WATS Access" is an access service offered for the provision of long distance services. It is provided at the closed end of WATS or 800/877/888 Service and does not allow for the completion of local calls as defined in the Company's Local Tariff. WATS Access is provided using a combination of Switched Access Service and Special Access Service as offered within this tariff.

#### WATS Serving Office

The term "WATS Serving Office" denotes a telephone company designated serving wire center where switching, screening and/or recording functions are performed in connection with a Special Access Line used with a Switching Interface as specified in Section V.<sup>1</sup>.

#### Wire Center

The term "Wire Center" denotes a location in which one or more central office switches, and cross connection equipment used for the provision of Company telecommunications services, are located.

*Continued on next page...*

<sup>1</sup> The use of the terms WATS or WATS-type throughout this tariff is primarily for ordering purposes and is not intended to restrict the use of the customer services when ordering Special Access and Switched Access in combination.

### III. GENERAL REGULATIONS (Continued)

<p><i>Continued from previous page...</i></p> <p><u>Wire Center Area</u></p> <p>The term "Wire Center Area" denotes the geographic area served by a Wire Center through the use of central office switching equipment, cross connection equipment, and subscriber loops.</p> <p><u>X.25 Protocol<sup>2</sup></u></p> <p>The term "X.25 Protocol" denotes an interface between Data Terminal Equipment and Data Circuit Terminating Equipment for terminals operating in the packet mode on public data networks.</p> <p><u>X.75 Protocol<sup>2</sup></u></p> <p>The term "X.75 Protocol" denotes terminal and transit call control procedures and data transfer system on circuits between packet switched data networks.</p>	
<p><b>G. <u>FIA Services Provided by More Than One Telephone Company</u></b></p> <p>When Switched Transport or Special Transport service is provided by more than one telephone company, the telephone companies involved will mutually agree upon one of the billing methods as set forth in 1. or 2. following based upon the type of access service and the interconnection arrangements between the telephone companies.</p>	
<p>The Telephone Company will notify the customer which billing method will be used. The customer will place the ASR as set forth in IV.C. following.</p> <p>1. <i>Single Company Billing</i></p> <p>The Single Company Billing method may be applied to FGA Switched Access Service.</p>	
<p>The telephone company receiving the ASR from the customer, as specified in IV.C.a.1. following, will arrange to provide the service, determine the applicable charges and bill the customer for the entire service in accordance with its Access tariff. The airline mileage is determined using the V&amp;H method.</p>	
<p>2. <i>Meet Point Billing</i></p> <p>Meet Point Billing is required when an access service is provided by multiple Telephone Companies for FGB, FGC and FGD Switched Access Services and Special Access. It is optional for FGA Switched Access Services.</p>	

---

<sup>2</sup> Effective August 3, 2005, Packet Switching Network Service as provided in Section XVIII.B. is no longer available to new customers. Moves, changes or additions will not be permitted to existing customers.

### III. GENERAL REGULATIONS (Continued)

<p>There are two (2) Meet Point Billing Options -- Single Bill and Multiple Bill. The Telephone Company must notify the customer of:</p> <ul style="list-style-type: none"> <li>- the Meet Point Billing Option that will be used,</li> </ul>	
<ul style="list-style-type: none"> <li>- the Telephone Company (s) that will render the bill(s),</li> </ul>	
<ul style="list-style-type: none"> <li>- the Telephone Company (s) to whom payment(s) should be remitted, and</li> </ul>	
<ul style="list-style-type: none"> <li>- the Telephone Company (s) that will provide the bill inquiry function.</li> </ul>	
<p>The Telephone Company shall provide such notification at the time that an ASR is placed requesting access service. Additionally, the Telephone Company shall provide this notice in writing thirty (30) days in advance of any change.</p> <p>a. Single Bill Option</p> <p>The Single Bill Option allows the customer to receive one (1) bill from one telephone company or its billing agent for access services.</p>	
<p>The Telephone Company (s) that renders the bill to the customer may provide to the customer, cross references to the other Telephone Company(s) service and/or the common circuit identifiers based upon industry standards. Should a billing dispute arise, the terms and conditions of the Billing Company(s) will apply.</p>	
<p>For usage rated access services the access minutes of use will be compiled by the Initial Billing Company and used by the Initial Billing Company and any subsequent Billing Company(s) for the development of access charges.</p> <ul style="list-style-type: none"> <li>- The Initial Billing Company for FGB, FGC and FGD Switched Access services is normally the end user's serving office and for WATS usage the Initial Billing Company is normally the WATS serving office. When the Initial Billing Company is other than the normally designated Telephone Company, the Telephone Company will notify the customer.</li> </ul>	
<ul style="list-style-type: none"> <li>- The Subsequent Billing Company(s) is any Telephone Company(s) in whose territory a segment of the Switched Transport Facility is provided and/or where the CDL is located.</li> </ul>	
<p>The Single Bill option provides three billing alternatives, Single Bill/Single Tariff, Single Bill/Pass-Through Billing and Single Bill/Multiple Tariff which are described following:</p> <p>(1) Single Bill/Single Tariff</p> <p>Each Telephone Company will receive an ASR or a copy of the ASR from the customer as specified in <i>IV.C.1.b.</i> following and arrange to provide the service. The Initial Billing Company will:</p> <ul style="list-style-type: none"> <li>- determine the applicable charges and bill in accordance with its tariff;</li> </ul>	
<ul style="list-style-type: none"> <li>- include all recurring and nonrecurring rates and charges of its tariff; and</li> </ul>	



### III. GENERAL REGULATIONS (Continued)

<ul style="list-style-type: none"> <li>- forward the bill to the customer.</li> </ul>	
<p>The customer will remit the payment to the Initial Billing Company.</p>	
<p>(2) Single Bill/Pass-Through Billing</p>	
<p>Each Telephone Company will receive an ASR or a copy of the ASR from the customer as specified in <i>IV.C.1.b.</i> following and arrange to provide the service. Each Telephone Company will:</p>	
<ul style="list-style-type: none"> <li>- determine its usage portion of Switched Transport and/or mileage portion of Special Transport as set forth in <i>III.G.1.b.(3)</i> following;</li> </ul>	
<ul style="list-style-type: none"> <li>- determine the applicable charges and bill in accordance with its tariff;</li> </ul>	
<ul style="list-style-type: none"> <li>- include all recurring and nonrecurring rates and charges of its tariff; and</li> </ul>	
<ul style="list-style-type: none"> <li>- forward the bill to the Initial Billing Company for meet point billed access services.</li> </ul>	
<p>The Initial Billing Company will:</p>	
<ul style="list-style-type: none"> <li>- apply usage data, when needed, to the bill and calculate the charges;</li> </ul>	
<ul style="list-style-type: none"> <li>- identify each involved Telephone Company's charges separately on the bill;</li> </ul>	
<ul style="list-style-type: none"> <li>- combine all the bills of the involved Telephone Companies of a meet point billed access service into one access bill;</li> </ul>	
<ul style="list-style-type: none"> <li>- forward the bill to the customer; and</li> </ul>	
<ul style="list-style-type: none"> <li>- advise the customer how to remit the payment, either directly to each Telephone Company involved in the provision of this meet point billed service; or, as a single payment made to the Initial Billing Company. If payments are to be sent directly to the Initial Billing Company, the Subsequent Billing Company(s) will provide the customer with written authorization for the payment arrangement.</li> </ul>	
<p>(a) Single Bill/Multiple Tariff</p>	
<p>Each Telephone Company will receive an ASR or a copy of the ASR from the customer as specified in <i>IV.C.1.b.</i> following and arrange to provide the service. The Initial Billing Company will:</p>	
<ul style="list-style-type: none"> <li>- determine each Telephone Company's usage portion of switched transport and/or mileage portion of special transport as set forth in <i>III.G.1.b.(3)</i> following;</li> </ul>	
<ul style="list-style-type: none"> <li>- determine the applicable charges and bill in accordance with each Telephone Company's tariff;</li> </ul>	

### III. GENERAL REGULATIONS (Continued)

<ul style="list-style-type: none"> <li>- include all recurring and nonrecurring charges for each involved Telephone Company;</li> </ul>	
<ul style="list-style-type: none"> <li>- identify each involved Telephone Company's charges separately on the bill;</li> </ul>	
<ul style="list-style-type: none"> <li>- forward the bill to the customer; and</li> </ul>	
<ul style="list-style-type: none"> <li>- advise the customer how to remit the payment, either directly to each Telephone Company involved in the provision of this meet point billed service; or, as a single payment made to the Initial Billing Company. If payments are to be sent directly to the Initial Billing Company, the Subsequent Billing Company(s) will provide the customer with written authorization for the payment arrangement.</li> </ul>	
<p>b. Multiple Bill Option</p> <p>The Multiple Bill option allows all Telephone Companies providing service to bill the customer for their portion of a jointly provided access service. Each Telephone Company will:</p> <ul style="list-style-type: none"> <li>- determine its portion of the Switched Transport and/or Special Transport as described in <i>III.G.1.b.(3)</i>;</li> <li>- determine the applicable charges and bill in accordance with its tariff;</li> <li>- include all recurring and nonrecurring rates and charges of its tariff; and</li> <li>- forward the bill to the customer.</li> </ul> <p>The customer will remit the payments directly to each Telephone Company.</p>	
<p>(1) Meet Point Billing Mileage Calculation</p> <p>Each Telephone Company's portion of the Switched Transport and/or Special Transport mileage will be determined as follows:</p> <p>(a) For Switched Access Services, determine the appropriate Switched Transport Facility total miles by computing the number of miles from the wire center in the Access Area (i.e., end user serving wire center, or WATS Serving Office), using the V&amp;H method. For Special Access Services, determine the appropriate Special Transport total miles by computing the number of miles between the serving wire centers involved (i.e., CDL serving wire center or Hub Wire Center or WATS Serving Office) using the V&amp;H method. Where the calculated miles include a fraction, the value is always rounded up to the next full mile.</p>	
<p>(b) Determine the billing percentage (BP), as agreed upon by the local exchange carriers in the state of Oregon. This represents the portion of the Service provided by each telephone company.</p>	

**III. GENERAL REGULATIONS** (Continued)

<p>(c) Forward Switched Access Service, using the BP method; 1.) multiply the number of access minutes of use times the number of airline miles as specified in (a), times the BP of each Telephone Company in (b), times the Switched Transport Facility rate; 2.) multiply the Switched Transport Termination rate times the number of access minutes times the quantity of terminations.</p>	
<p>For Special Access, multiply the number of airline miles in (a), times the BP for each Telephone Company in (b), times the Special Transport rate.</p>	
<p>(2) All other appropriate recurring charges in each telephone company's Access tariff are applicable.</p>	

## IV. ORDERING OPTIONS FOR FIA

<p><b>A. <u>General</u></b></p>	<p>This section sets forth the regulations and order related charges for ASRs to provide the customer with FIA. These charges are in addition to other applicable charges in other sections of this tariff.</p> <p><b>1. <i>Ordering Conditions</i></b></p> <p style="padding-left: 20px;">a. A customer may order any amount of FIA (Switched or Special) of the same interface type, same Feature Group, same BSA or same Special Access between the same locations on a single ASR. A customer may order the changed use of Switched Access and Special Access over the same high capacity facility however, separate ASRs are required. The methodology for shared use is described in VI.F.7..</p> <ul style="list-style-type: none"> <li>- ASRs for FGA or BSA-A must be in number of lines required.</li> <li>- ASRs for FGB, FGC, FGD, BSA-B, BSA-C, BSA-D and SAC Access Service must be in Busy Hour Minutes of Capacity (BHMC).</li> </ul> <p style="padding-left: 20px;">Additional ASR requirements for Switched Access Service are described in Section V..</p>
	<p style="padding-left: 20px;">b. The customer shall supply all details necessary to complete an order. The details may include the following: requested service date, customer name, CDL, end office, Interface Arrangement, type of Switched Access or Special Access, Supplemental Features, End Office Services and Signaling Interface, and originating and terminating capacity required. The customer may also be required to provide end user name and location, end user contact person, and end user access hours to complete an order for Special Access.</p>
	<p>When a customer orders mixed interstate and intrastate Switched Access, the customer is required to provide an estimate of the percent of traffic, which will be intrastate. If the customer fails to provide this estimate the order will not be processed until such time as the customer provides this estimate.</p>
	<p>When a customer orders mixed-use Special Access service, the customer must indicate the jurisdiction based on the criteria as described in Section VI.A.6..</p>
	<p>For Packet Switching Network Service, the packet carrier must provide a Percent Intrastate Usage (PIU) in the Main Remarks section of the ASR when service is initially ordered. This PIU will be used as the basis for prorating the packet usage charges to the interstate and intrastate jurisdictions. The packet carrier may submit an updated PIU report in writing at any time following one full month's billing. The updated report will become effective on the first day of the next monthly billing period which begins at least fifteen (15) business days after the date the revised report is received by the Company.</p>
	<p style="padding-left: 20px;">c. When the Alternate Traffic Routing Optional Arrangement is ordered, more than one CDL will be supplied and the number of trunks or BHMC for FGB, FGC and FGD to each CDL shall be specified.</p>

**IV. ORDERING OPTIONS FOR FIA (Continued)**

<p>When the Alternate Traffic Routing Basic Serving Element (BSE) is ordered, more than one CDL will be supplied and the number of trunks or BHMC for BSA-B, BSA-C and BSA-D to each CDL shall be specified.</p>	
<p>d. The customer shall order SAC Access Service, as described in <i>V.B.1.e.</i>, in the same manner as ordering FGD with the following exceptions. For 500 SAC Access Service or 900 SAC Access Service, customers may request direct connections only to those offices designated by the Company as 500 SAC Access Service or 900 SAC Access Service screening offices. All 500 NXX or 900 NXX code assignments and administration shall be in accordance with the North American Numbering Plan (NANP). 800/877/888 SAC Access Service is offered only with 800/877/888 Customer Identification Function as described in Section V. and with 800/877/888 Data Base Query Service as described in Section V.. Customers may request 800/877/888 SAC access connections to suitably equipped end offices and access tandem offices. A list of those offices will be provided upon request. All 800/877/888 number assignments shall be administered by the Number Administration Service Center (NASC) through the Service Management System (SMS).</p>	
<p>500 NXX codes or 900 NXX Codes to be activated and/or deactivated with 500 SAC Access Service or 900 SAC Access Service, must be provided to the Company at least thirty (30) business days prior to the effective date of the change.</p>	
<p>An ASR is required by the Company for 500 NXX codes or 900 NXX codes to be activated or deactivated on an access facility level basis. The Subsequent Ordering Charge - Switched Access as described in Section V. will apply. In addition to the Subsequent Ordering Charge - Switched Access, the NXX Translation Charge as described in Section V., shall apply to each 500 NXX code activated or deactivated in a Company switch capable of performing the customer identification function for 500 SAC Access Service. Customer assigned codes, for which an ASR has not been received, will be blocked.</p>	
<p>When SAC Access Service is not terminated over a WATS Access Line as described in <i>VI.A.1.</i>, the customer must notify the Company of all local exchange telephone numbers to which SAC Access Service traffic is designated so that the Company can balance the end office in accordance with standard Company engineering practices for heavy volume lines.</p>	
<p>e. To determine if adequate central office facilities (i.e., trunk circuits) for FGD or BSA-D will be available on the conversion date to equal access and to be eligible for the allocation in the following paragraph all customers (including those customers who convert existing FGA, FGB, FGC, BSA-A, BSA-B and BSA-C to FGD or to BSA-D) must order FGD or BSA-D one hundred twenty (120) days prior to an end office conversion to equal access.</p>	
<p>When trunk circuits are not available to meet the demand an allocation of available trunk circuits will be required. The allocation of available facilities is a three (3) step process as described below:</p>	

#### IV. ORDERING OPTIONS FOR FIA (Continued)

<p>In this example assume nine Interexchange Carriers (ICs) have ordered BHMCs which necessitate one thousand (1,000) FGD trunks where only eight hundred (800) trunk circuits are available at the conversion date.</p> <p>Step 1: Provide an initial flat twenty-five percent (25%) distribution of available trunk circuits to each requesting IC except for incremental requests over existing levels of FGC. (See table in Step 3.)</p> <ul style="list-style-type: none"><li>- <math>25\% \times 800</math> (available facilities) = 200</li><li>- <math>\frac{200}{(9-1)} = 25</math></li></ul>	
<p>Step 2: Assign all remaining trunk circuits proportionately, working from bottom up until ICs, as a result of the proration, are assigned less facilities than desired. First determine facilities available for apportionment.</p> <ul style="list-style-type: none"><li>- <math>800 - 175 = 625</math> (eligible ICs are A, B, C, D, E, F)</li><li>- <math>\frac{(\text{Desired Facilities})}{(\text{Total Desired Facilities})} \times \text{Remaining Facilities}</math> (of Remaining Facilities)</li><li>- <math>F = \frac{70}{1000 - 50} \times 625 = 46</math> (assign only 45)**)</li><li>- <math>E = \frac{80}{1000 - 120} \times (625 - 45) = 53</math></li></ul> <p>(E receives less facilities than originally ordered, i.e., <math>53 + 25 = 78</math>)</p>	

**IV. ORDERING OPTIONS FOR FIA (Continued)**

<p>Step 3: When an IC receives less facilities than desired, the remaining ICs are allocated according to the following factor:</p> $\frac{\text{Remaining Facilities}}{\text{Total Desired Facilities of Remaining Eligible ICs of Access}} = \frac{625 - 98}{1000 - 200} = \frac{527}{800} = .659$ <p>- IC #4 = 100 x .659 = 66          - IC #3 = 200 x .659 = 132          - IC #2 = 200 x .659 = 132          - IC #1 = 300 x .659 = 197</p>						
<u>ICs</u>	<u>Demand Desired (In Trunks)</u>	<u>Resources Available</u>	<u>Step 1 Flat 25% Distribution</u>	<u>Step 2</u>	<u>Step 3</u>	<u>Total Assigned Trunk Circuits</u>
A	300	---	25	---	197	222
B	200	---	25	---	132	157
C <sup>3</sup>	200	---	0	---	132	132
D	100	---	25	---	66	91
E	80	---	25	53	---	78
F	70	---	25	45 <sup>4</sup>	---	70
G	25	---	25	---	---	25
H	15	---	15 <sup>4</sup>	---	---	15
I	10	---	10 <sup>4</sup>	---	---	1
Total	1,000	800	175	98	527	800
<p>f. The provision of Special Access requires the selection of a Terminating Option as defined in VI.C.. When a customer orders DS3 Special Access, he may specify, on the ASR, if the interface is to be electrical or an optical interface. In the event the customer does not specify an interface preference for DS3, the Company will provide an electrical interface. When a customer orders a Fiber Connect SAL he must specify, whether the interface is to be an electrical or optical termination and indicate the Network Channel Interface (NCI) code on the ASR. The customer must order Fiber Connect as four (4) DS1s.</p>						
<p>When a customer orders DS3C Special Access, the Company will provide an optical interface unless service is provided via microwave, in which case an electro-magnetic interface is provided, or unless the customer specifies on the ASR a request for an electrical interface.</p>						

<sup>3</sup> Request for additional trunk circuits by an IC with existing FGC or BSA-C.

<sup>4</sup> Will not assign more than desired.

**IV. ORDERING OPTIONS FOR FIA (Continued)**

<p>g. An ASR is required from the customer to add 1+ coin traffic from an end office. At the customer's option, the ASR can be issued at a 1+ coin tandem or end office level. For an initial customer order at a 1+ coin tandem, the Company must receive the request at least one hundred twenty (120) calendar days prior to the requested effective date. Standard provisioning intervals will apply to subsequent orders involving that 1+ coin tandem.</p>	
<p>The customer must provide the Company with written notification stating that an order is being submitted pursuant to an agreement with a secondary service provider prior to the routing of 1+ interLATA coin traffic to a provider other than the customer.</p>	
<p>h. When ordering Operator Services, an ASR is required to establish a new FGC or FGD trunk group(s) or to add Operator Services to an existing FGC or FGD trunk group between the Company's Operator Services Switching Location and one CDL in the same LATA.</p>	
<p>When measurement capability does not exist for Operator Services per call charges, a forecast of the number of Operator Services calls anticipated is required from the customer as specified in <i>IX.D.2.d.</i> when the initial order for Operator Services is placed.</p>	
<p>i. When ordering SS7 Out of Band Signaling, as described in Section V., the customer shall provide an ASR specifying a reference to existing CCS7 Access service facilities or a reference to a related ASR for CCS7 Access Service as described in the Company's Interstate Tariff. The customer's ASR shall also include STP point codes, STP location identifier codes, FGD or BSA-D trunk or 800/877/888 Service Access trunk circuit identification codes, and switch type. When ordering SS7 Out of Band Signaling for FGD or BSA-D, the customer shall specify that all traffic carried by the FGD or BSA-D will be equipped with Out of Band Signaling. The customer shall work cooperatively with the Company to determine the number of CCS7 access service connections required to handle the customer's SS7 Out of Band Signaling traffic.</p>	
<p>j. When ordering Expanded Interconnection Services (EIS) as described in <i>XIX.E.</i>, the customer shall place an ASR for the Cross Connect, as described in Section V. and <i>VI.A.1.d.</i>, to interconnect the facilities of the Company to the facilities of the customer. Each service application used with EIS will require a separate ASR. When ordering additions or changes to the existing EIS facilities, the customer must refer to the specific EIS facilities affected by the addition or change.</p>	
<p>k. When ordering FGD or BSA-D Switched Access with 950-XXXX Access as described in Section V., the customer shall provide an ASR specifying which 950-XXXX access code(s) are to be routed and the FGD or BSA-D Switched Access Service over which resulting originating 950-XXXX access code calls are to be routed.</p>	
<p>l. When ordering Carrier Identification Parameter (CIP) as described in Section V., the customer shall provide an ASR specifying a reference to existing FGD or BSA-D switched access services or reference to a related ASR for FGD or BSA-D switched access services. The customer's ASR shall specify the information necessary to identify the trunk group to which the CIP is to be added.</p>	



**IV. ORDERING OPTIONS FOR FIA (Continued)**

<p><b>2. Provision of Other Services</b></p> <p>a. At the option of a customer, Recording and Processing, Additional Labor, Telecommunications Service Priority (TSP), Testing and Special Routing services may be ordered with an ASR at the same time the ASR is accepted by the Company. Such requests will be considered to be supplemental to the ASR. The rates and charges for these services as specified in other sections of this tariff will apply in addition to the ordering charges specified in this section and the rates and charges for the Switched Access or Special Access with which they are associated.</p>	
<p>b. The items listed in a. may subsequently be added to the ASR at any time, up to and including the service date established by the ASR. When ordered subsequently, charges for ASR modifications as described in IV.B.2. will apply.</p>	
<p><b>3. Special Construction</b></p> <p>The regulations, rates and charges for Special Construction as described in Section XI. are in addition to the regulations, rates and charges specified in this section.</p>	
<p><b>4. Expanded Interconnection Service (EIS)</b></p> <p>The regulations rates and charges for EIS in Section XIX. are in addition to the regulations, rates and charges specified in this section.</p>	
<p><b>B. <u>Access Service Request</u></b></p> <p>An ASR is used by the Company to receive orders for the following types of FIA requested by the customer:</p> <ul style="list-style-type: none"> <li>- Switched Access as described in Section V.,</li> <li>- Special Access as described in Section VI., and</li> <li>- Other Services as described in other sections of the tariff.</li> </ul> <p><b>1. Service Date Intervals</b></p> <p>The time required to provision service is known as the service date interval. Such intervals will be established in accordance with published service date interval guidelines which are available to customers upon request. The service date interval guidelines will apply to ASRs and will specify the quantities of FIA that can be provided on the same service date. The customer may request a service date other than that established pursuant to the service date interval guidelines. The Company, where possible, will establish the service date in accordance with such request, subject to other applicable provisions of this tariff.</p>	

**IV. ORDERING OPTIONS FOR FIA** (Continued)

<p><b>2. ASR Modifications</b></p> <p>The customer may request a modification of its ASR prior to the service date. The Company will make every effort to accommodate a requested modification when it is able to do so with the normal work force assigned to complete such an ASR within normal business hours. If the modification cannot be made with the normal work force during normal business hours, the Company will notify the customer. If the customer still desires the ASR modification, the Company will schedule a new service date. All charges for ASR modifications will apply on a per occurrence basis. Where a new ASR may be required the appropriate charges as set forth in other sections of this tariff will be applicable.</p>					
<p>Any increase in the number of Switched Access lines for FGA or BSA-A; trunks or BHMCs for FGB, FGC, FGD, BSA-B, BSA-C, BSA-D and SAC Access Service or Special Access circuits will require the issuance of a new ASR for the incremental capacity.</p> <p>a. Service Date Change Charge</p> <p>ASR service dates may be changed, however, a Service Date Change Charge will apply for each service date change after the Plant Test Date on the ASR.</p>					
<p>The new service date may not exceed the original service date by more than thirty (30) days. If the requested service date is more than thirty (30) days after the original service date, the ASR will be considered canceled by the Company and cancellation charges in <i>IV.B.6.</i> will apply. A new ASR will be issued with the new service date.</p>					
<p>For Special Access, except as specified below, the new service date may not exceed the original service date by more than thirty (30) calendar days. If the requested service date is more than thirty (30) calendar days after the original service date, the ASR will be canceled by the Company. Cancellation charges in <i>IV.B.6.</i> will apply and the ASR will be reissued with the new service date unless the customer indicates that billing for the service is to commence as in <i>IV.B.6.a.</i></p>					
<p>With the agreement of the Company, a new service date may be established that is prior to the original service date and the provisions set forth in <i>IV.B.2.d.</i> will apply in addition to the Service Date Change Charge.</p> <table data-bbox="357 1323 1250 1386"> <tr> <td></td> <td style="text-align: right;"><u>Rate</u></td> </tr> <tr> <td>Service Date Change Charge (SUM)</td> <td style="text-align: right;">\$63.97</td> </tr> </table>		<u>Rate</u>	Service Date Change Charge (SUM)	\$63.97	
	<u>Rate</u>				
Service Date Change Charge (SUM)	\$63.97				
<p>b. Partial Cancellation Charge</p> <p>Any decrease in the number of Switched Access lines for FGA or BSA-A; trunks or BHMC for FGB, FGC, FGD, BSA-B, BSA-C, BSA-D and SAC Access Service, or Special Access circuits will be treated as a partial cancellation.</p>					
<p>A customer may cancel any number of Special Access circuits. For Switched Access Services, the capacity canceled may be subject to the Minimum Capacity Requirements as in <i>IV.E.</i></p>					

**IV. ORDERING OPTIONS FOR FIA (Continued)**

<p>When a customer partially cancels the service ordered on an ASR, charges will apply as follows:</p> <p>(1) Except as specified in <i>IV.B.6.d.</i>, when an ASR for Switched Access Service or Special Access Service is partially canceled on or after the Application Date, the Initial Ordering Charge for Switched or Special Access will apply. A Subsequent Ordering Charge will also apply for the reissuance of a supplement order.</p>	
<p>(2) When an ASR for Special Access Service is partially cancelled on or after the Plant Test Date, the Initial and Subsequent Ordering Charges will apply, plus the Installation Charge(s) associated with the items canceled.</p>	
<p>(3) When a customer cancels part of a Special Access ASR for which billing has commenced as provided in <i>IV.B.2.a.</i> and <i>IV.B.6.a.</i>, cancellation charges in <i>IV.B.6.c.(3)</i> will apply to that part of the ASR being canceled.</p>	
<p>c. Discontinuance of Service</p> <p>A customer may discontinue FIA that is in service at any time. The request for discontinuance of service must be received by the Company at least two (2) business days prior to the date on which service is to be disconnected and billing discontinued. The request may be verbal or written, however, a verbal request must be followed, within ten (10) days, by written confirmation. The written confirmation serves as a confirmation of the verbal request rather than a request itself.</p>	
<p>The customer must notify the Company of a delay or cancellation in the discontinuance request prior to the disconnect date. The Company, where possible, will change the disconnect date in accordance with such a request. Billing and service will then continue until the new requested disconnect date. If a service is discontinued prior to the expiration of the Minimum Period in <i>IV.B.4.</i>, the Minimum Period Charges in <i>IV.B.5.</i>, may apply. For Switched Access Service, the capacity discontinued may be subject to the Minimum Capacity Requirements in <i>IV.E.</i>.</p>	
<p>d. Design Change Charge</p> <p>The customer may request a design change to a pending ASR for both Switched and Special Access or request a change to an existing Switched Access Service. A design change is a change, which requires engineering review. The regulations, rates and charges for a design change are as described in Section V. for Switched Access Service, and Section <i>VI.F.1.d.(3)</i> for Special Access Service, and are in addition to the regulations, rates and charges specified in this section.</p>	
<p>e. Expedited Order Charge</p> <p>When placing an Access Service Request a customer may request a service date that is prior to the Telephone Company's published service date interval. If the Telephone Company determines that the service can be provided on the requested date, an Expedited Order Charge will apply.</p>	
<p>A customer may also request an earlier service date on a pending Access Service Request. If the customer's request can be accommodated, a Service Date Change Charge as described in Section <i>IV.B.2.a.</i> will apply in addition to the Expedited Order Charge.</p>	

**IV. ORDERING OPTIONS FOR FIA (Continued)**

<p>If the Telephone Company is subsequently unable to meet an agreed upon expedited service date, the Expedited Order Charge will not apply.</p>																					
<p>In the event that the Telephone Company provides service on an expedited basis by customer request and the customer then delays service, an additional Service Date Change Charge as described in Section IV.B.2.a. will apply.</p>																					
<p>The Expedited Order Charge applies per order, based on the requested service date. A request to expedite service to be available the next day is a one (1) day expedite, a request for service in two (2) days is a two (2) day expedite, and so on to a request for service a week from the request date is a seven (7) day expedite. Expedited orders for same day service are not available. If the requested service date is at the published service date interval or later, no Expedited Order Charge will apply.</p>																					
<p>Rates for Expedited Order Charges are as follows:</p> <table data-bbox="349 772 1258 1077"> <thead> <tr> <th></th> <th style="text-align: right;"><u>Charge</u></th> </tr> </thead> <tbody> <tr> <td>One Day Expedite</td> <td style="text-align: right;">\$505.00</td> </tr> <tr> <td>Two Day Expedite</td> <td style="text-align: right;">484.00</td> </tr> <tr> <td>Three Day Expedite</td> <td style="text-align: right;">462.00</td> </tr> <tr> <td>Four Day Expedite</td> <td style="text-align: right;">441.00</td> </tr> <tr> <td>Five Day Expedite</td> <td style="text-align: right;">436.00</td> </tr> <tr> <td>Six Day Expedite</td> <td style="text-align: right;">432.00</td> </tr> <tr> <td>Seven Day Expedite</td> <td style="text-align: right;">428.00</td> </tr> <tr> <td>Eight Day Expedite</td> <td style="text-align: right;">428.00</td> </tr> <tr> <td>Nine Day Expedite</td> <td style="text-align: right;">428.00</td> </tr> </tbody> </table>		<u>Charge</u>	One Day Expedite	\$505.00	Two Day Expedite	484.00	Three Day Expedite	462.00	Four Day Expedite	441.00	Five Day Expedite	436.00	Six Day Expedite	432.00	Seven Day Expedite	428.00	Eight Day Expedite	428.00	Nine Day Expedite	428.00	
	<u>Charge</u>																				
One Day Expedite	\$505.00																				
Two Day Expedite	484.00																				
Three Day Expedite	462.00																				
Four Day Expedite	441.00																				
Five Day Expedite	436.00																				
Six Day Expedite	432.00																				
Seven Day Expedite	428.00																				
Eight Day Expedite	428.00																				
Nine Day Expedite	428.00																				
<p><b>3. <i>Select of Facilities for Access Service</i></b></p> <p>Requests for a specific circuit is not an option of the customer except as provided for under Special Facilities Routing of FIA in Section X..</p>																					
<p><b>4. <i>Minimum Period</i></b></p> <p>a. The Minimum Period for which Special Access is provided and for which charges are applicable, is one month, except as in c. and d..</p>																					
<p>b. The Minimum Period for Miscellaneous Services is in Section VII..</p>																					
<p>c. The Minimum Period for Ancillary Services is in Section IX..</p>																					
<p>d. The Minimum Period for temporary videoband and program audio Special Access is the minimum period for which rates are established in Section VI.G. and VI.H..</p>																					
<p>e. The Minimum Period for FIA provided under Special Construction provisions and for which charges are applicable is in Section XI..</p>																					

**IV. ORDERING OPTIONS FOR FIA** (Continued)

<p>f. The Minimum Period for FGA, FGB, FGC, BSA-A, BSA-B, BSA-C, SAC Access Service, and for FGD or BSA-D ordered after the conversion of an end office to equal access is three (3) months. For the application of the minimum period charges for Switched Access Service FGA, FGB, FGC, BSA-A, BSA-B, BSA-C, SAC Access Service, and for FGD and BSA-D ordered after the conversion of an end office to equal access, it is assumed the last identical capacity placed in service is the first one discontinued.</p>	
<p>g. For FGD or BSA-D ordered prior to the conversion of an end office to equal access and a.) canceled prior to the conversion date, the Cancellation Charge in <i>IV.B.6.</i> applies or b.) canceled on or after the equal access conversion date, the Discontinuance Charge as in <i>IV.B.7.</i> applies.</p>	
<p><b>5. Minimum Period Charges</b></p> <p>When FIA are discontinued prior to the expiration of the Minimum Period, charges are applicable for the remaining month(s) and/or fraction thereof of the Minimum Period.</p>	
<p>The Minimum Period Charge will be determined as follows:</p> <p>a. For Special Access, the charge is the applicable monthly rate for the service(s) in <i>VI.G.</i>.</p>	
<p>b. For FGD or BSA-D ordered prior to conversion of an end office to equal access, but canceled after the equal access conversion date, the Discontinuance Charge in <i>IV.B.7.</i> applies.</p>	
<p>c. For part-time or occasional program audio Special Access services, the rates in <i>VI.F.1.</i> and <i>VI.G.6.</i> through <i>VI.G.9.</i> will apply.</p>	
<p>d. For FGA, FGB, BSA-A and BSA-B type services where measurement equipment is not available, the charge for each remaining month and/or fraction thereof will be equal to the applicable Minimum Monthly Charge in Section <i>V.</i>.</p>	
<p><b>6. Cancellation of an ASR</b></p> <p>a. A customer may cancel ordered FIA on any date prior to the service date. The cancellation date is the date the Company receives written or verbal notice from the customer that the ASR is to be cancelled. The verbal notice must be followed by written confirmation within ten (10) days.</p>	
<p>For Switched Access, if a customer is unable to accept service within thirty (30) calendar days of the original service date, the ASR shall be considered canceled and charges in <i>c.</i> and <i>d.</i> will apply. In such instances, the cancellation date shall be the 31st calendar day beyond the original service date of the ASR.</p>	
<p>For Special Access, if a customer is unable to accept service within thirty (30) calendar days of the original service date, the customer has the choice of the following options:</p> <ul style="list-style-type: none"> <li>- the Special Access ASR shall be canceled and charges in will apply, or</li> </ul>	
<ul style="list-style-type: none"> <li>- billing for the service will commence.</li> </ul>	

**IV. ORDERING OPTIONS FOR FIA (Continued)**

<p>In either case, the cancellation date or the billing date shall commence on the 31st calendar day beyond the original service date of the ASR.</p>	
<p>b. ASR costs are considered to have started when the Company incurs any cost in connection therewith or in preparation thereof which would not otherwise have been incurred. These costs include but are not limited to preliminary engineering, orders to suppliers, and other similar items of cost. For purposes of determining cancellation charges, the costs are considered to have started the day the Company receives the ASR. For all ASRs this is known as the Application Date. The cancellation charges will not apply until the customer is notified of such charges.</p>	
<p>c. When a customer cancels an ASR for the installation of new service, or an ASR to modify to existing service, charges will apply as follows:</p> <p>(1) Except as specified in <i>d.</i>, when an ASR for Switched Access Service is canceled on or after the Application Date, all nonrecurring charges associated with the Switched Access ASR, will apply as specified in Section V..</p>	
<p>(2) When an ASR for Special Access Service is canceled on or after the Application Date and before the Plant Test Date, the appropriate Service Ordering Charge will apply as specified in <i>VI.F.1.d.(1)</i>.</p>	
<p>When an ASR for Special Access Service is canceled on or after the Plant Test Date, the Initial or Subsequent Ordering Charge and Service Installation Charges will apply as specified in <i>VI.F.1.d.</i>, plus any Installation Charges associated with supplemental features or multiplexing arrangements.</p>	
<p>(3) When a customer chooses to commence billing rather than cancel an ASR for Special Access as in <i>a.</i>, the customer must submit an ASR prior to calendar day 31 from the original service date and request a service date change. The new service date may not exceed the original service date by more than one hundred twenty (120) calendar days. Charges in <i>IV.B.2.a.</i> will apply. for each subsequent service date change request after calendar day 31, not to exceed one hundred twenty (120) calendar days.</p>	
<p>When a customer elects to commence billing, monthly recurring charges will begin accruing at calendar day 31 after the original service date. Upon completion of the ASR, the initial bill for Special Access Service will include these accrued charges and any additional nonrecurring charges in addition to billable charges specified in <i>III.D.1.c.</i></p>	
<p>If the ASR is not completed within one hundred twenty-one (121) calendar days of the original service date, the ASR will be canceled. Cancellation charges in <i>c.(2)</i> will apply. In addition, the customer will be billed the accrued monthly recurring charges specified above plus any additional nonrecurring charges applicable for the Special Access Service. These charges will be computed commencing at day 31 after the original service date up to and including the cancellation date, not to exceed ninety (90) days of service (one hundred twenty (120) days from the original service date). The Company will not reissue an ASR with a new service date beyond one hundred twenty-one (121) calendar days. It will be the customer's responsibility to submit a new ASR for Special Access Service.</p>	

**IV. ORDERING OPTIONS FOR FIA** (Continued)

<p>d. For cancellation of an ASR for Switched Access FGD or BSA-D before an end office converts to equal access, cancellation charges will apply if the Company is notified of the cancellation within a period of twelve (12) months prior to the scheduled service date. Cancellation charges apply to each trunk canceled.</p>																											
<p>When (due to a shortage of FGD or BSA-D facilities) an allocation of FGD or BSA-D facilities is made, cancellation charges apply only to circuits allocated to the customer.</p>																											
<p>Cancellation charges will accrue to the maximum in equal monthly increments (i.e., maximum cancellation charge divided by twelve (12)) beginning twelve (12) months before an end office converts to equal access. Maximum cancellation charges are listed in Section IV.B.8. following. The charge applied will be the accrued charge in the month during which notice of cancellation is received by the Company.</p> <table border="0" data-bbox="357 703 1396 1197"> <thead> <tr> <th style="text-align: center;"><u>Month During Which Notice is Received Before Conversion Date</u></th> <th style="text-align: center;"><u>Charge (Per Trunk Cancelled)</u></th> </tr> </thead> <tbody> <tr><td style="text-align: center;">12</td><td style="text-align: right;">\$32.67</td></tr> <tr><td style="text-align: center;">11</td><td style="text-align: right;">65.35</td></tr> <tr><td style="text-align: center;">10</td><td style="text-align: right;">98.02</td></tr> <tr><td style="text-align: center;">9</td><td style="text-align: right;">130.70</td></tr> <tr><td style="text-align: center;">8</td><td style="text-align: right;">163.37</td></tr> <tr><td style="text-align: center;">7</td><td style="text-align: right;">196.05</td></tr> <tr><td style="text-align: center;">6</td><td style="text-align: right;">228.72</td></tr> <tr><td style="text-align: center;">5</td><td style="text-align: right;">261.39</td></tr> <tr><td style="text-align: center;">4</td><td style="text-align: right;">294.07</td></tr> <tr><td style="text-align: center;">3</td><td style="text-align: right;">326.74</td></tr> <tr><td style="text-align: center;">2</td><td style="text-align: right;">359.42</td></tr> <tr><td style="text-align: center;">1</td><td style="text-align: right;">392.09</td></tr> </tbody> </table>	<u>Month During Which Notice is Received Before Conversion Date</u>	<u>Charge (Per Trunk Cancelled)</u>	12	\$32.67	11	65.35	10	98.02	9	130.70	8	163.37	7	196.05	6	228.72	5	261.39	4	294.07	3	326.74	2	359.42	1	392.09	
<u>Month During Which Notice is Received Before Conversion Date</u>	<u>Charge (Per Trunk Cancelled)</u>																										
12	\$32.67																										
11	65.35																										
10	98.02																										
9	130.70																										
8	163.37																										
7	196.05																										
6	228.72																										
5	261.39																										
4	294.07																										
3	326.74																										
2	359.42																										
1	392.09																										

**IV. ORDERING OPTIONS FOR FIA** (Continued)

<p><b>7. Discontinuance of Switched Access FGD or BSA-D</b></p> <p>A Discontinuance Charge applies if a customer discontinues FGD or BSA-D service provided at the conversion of an end office to equal access. The Discontinuance Charge applies to each FGD or BSA-D trunk discontinued. For purposes of calculating the Discontinuance Charge the Maximum Discontinuance Charge will be amortized in equal monthly increments (i.e., Maximum Discontinuance Charge divided by twelve (12)) over a twelve (12) month period beginning on the date the end office converts to equal access. The Maximum Discontinuance Charge is equal to the FGD or BSA-D Maximum Cancellation Charge in IV.B.8.. The charge assessed will be the unamortized portion of the Maximum Discontinuance Charge.</p> <table border="0"> <thead> <tr> <th style="text-align: left;"><u>Month During Which Service is Discontinued After Conversion Date</u></th> <th style="text-align: right;"><u>Charge (Per Trunk Cancelled)</u></th> </tr> </thead> <tbody> <tr><td>12</td><td style="text-align: right;">\$392.09</td></tr> <tr><td>11</td><td style="text-align: right;">359.42</td></tr> <tr><td>10</td><td style="text-align: right;">326.74</td></tr> <tr><td>9</td><td style="text-align: right;">294.07</td></tr> <tr><td>8</td><td style="text-align: right;">261.39</td></tr> <tr><td>7</td><td style="text-align: right;">228.72</td></tr> <tr><td>6</td><td style="text-align: right;">196.05</td></tr> <tr><td>5</td><td style="text-align: right;">163.37</td></tr> <tr><td>4</td><td style="text-align: right;">130.70</td></tr> <tr><td>3</td><td style="text-align: right;">98.02</td></tr> <tr><td>2</td><td style="text-align: right;">65.35</td></tr> <tr><td>1</td><td style="text-align: right;">32.67</td></tr> </tbody> </table>		<u>Month During Which Service is Discontinued After Conversion Date</u>	<u>Charge (Per Trunk Cancelled)</u>	12	\$392.09	11	359.42	10	326.74	9	294.07	8	261.39	7	228.72	6	196.05	5	163.37	4	130.70	3	98.02	2	65.35	1	32.67
<u>Month During Which Service is Discontinued After Conversion Date</u>	<u>Charge (Per Trunk Cancelled)</u>																										
12	\$392.09																										
11	359.42																										
10	326.74																										
9	294.07																										
8	261.39																										
7	228.72																										
6	196.05																										
5	163.37																										
4	130.70																										
3	98.02																										
2	65.35																										
1	32.67																										
<p><b>8. FGD or BSA-D Maximum Per Trunk Cancellation Charge</b></p> <table border="0"> <thead> <tr> <th></th> <th style="text-align: right;"><u>Rate</u></th> </tr> </thead> <tbody> <tr> <td>Cancellation Charge</td> <td style="text-align: right;">\$392.09</td> </tr> </tbody> </table>			<u>Rate</u>	Cancellation Charge	\$392.09																						
	<u>Rate</u>																										
Cancellation Charge	\$392.09																										
<p><b>C. <u>Access Service Requests for Services Provided by More Than One Telephone Company</u></b></p> <p>Switched or Special Access Services provided by more than one telephone company are services where one end of the Switched Transport or Special Transport service is in the operating territory of one telephone company and the other end of the service is in the operating territory of a different telephone company.</p>																											



**IV. ORDERING OPTIONS FOR FIA (Continued)**

<p>The ordering procedure for this service is as set forth in 1. and 2. following. The telephone company will notify the customer, identifying which ordering procedures will apply.</p> <p><b>1. Single Company Billing</b></p> <p>The telephone company receiving the ASR from the customer will arrange to provide the service and bill the customer as set forth in <i>III.G.1.a.</i> preceding. The customer will place the ASR with the telephone company as follows:</p> <p>For Switched Access Services the customer will place the ASR with the telephone company in whose territory the following is located:</p> <ul style="list-style-type: none"> <li>- FGA – dial tone office</li> </ul>	
<p>When the preceding is not in the same telephone company's territory as the customer designated location (CDL), the customer must supply a copy of the ASR to the telephone company in whose territory the CDL is located.</p>	
<p><b>2. Meet Point Billing</b></p> <p>Each telephone company will provide its portion of the Switched Transport or Special Transport Service within its operating territory to the meet point with the other telephone company(s). The BP will be determined by the telephone companies involved in providing the FIA service.</p>	
<p>For all Switched Access Services and all Special Access Services the order will be placed with the telephone company based upon industry guidelines.</p>	
<p><b>D. <u>Switched Access Minimum Capacity Requirements</u></b></p>	
<p>1. When a customer orders Switched Access, it will be provided subject to the minimum capacity provisions set forth in <i>IV.E.2.</i> through <i>IV.E.6.</i> following.</p>	
<p>2. There is no minimum capacity for Interface Arrangements 1 and 2 as set forth in <i>IV.E.4.</i> following. However, for Interface Arrangements 3 through 10 the minimum capacity is as set forth in <i>IV.E.5.</i> following for which charges are applicable as set forth in <i>IV.E.4.</i> following. A description of Interface Arrangements is found in <i>V.B.3.b.</i> following.</p>	
<p>3. For the purpose of administering the minimum capacity provisions, different Switched Access feature groups for the same customer may be grouped together if the facilities provided for all the connections are the same and terminate in the same facilities terminal in the same Company access tandem or end office.</p>	
<p>4. The following table provides the total capacity of the interface and the thresholds for minimum ASR requirements. When the customer requests one of the following it is required to order sufficient lines for FGA, and sufficient BHMCs for FGB, FGC, FGD and SAC Access Service to satisfy the minimum capacity.</p>	

**IV. ORDERING OPTIONS FOR FIA** (Continued)

When the customer requests more than one of the same Interface Arrangements, it is required to meet the total minimum capacity of all such Interface Arrangements.

<u>Interface Arrangement</u>	<u>Interface Type</u>	<u>Interface Name</u> (circuits)	<u>Total Capacity</u> (circuits)	<u>Minimum Capacity</u>
1	Voice Frequency	2-Wire	1	NA
2	Voice Frequency	4-Wire	1	NA
3	Analog	Group	12	9
4	Analog	Supergroup	60	42
5	Analog	Mastergroup	600	420
6	Digital	DS1	24	17
7	Digital	DS1C	48	34
8				
9	Digital	DS3	672	471
10	Digital	DS3C	1344	941

## V. SWITCHED ACCESS

<p><b>A. <u>General</u></b></p> <p>The Telephone Company adopts Section <i>VIII.</i>, Terms and Conditions and associated rates in Section <i>XXII.</i> of ZiPLY Fiber Tariff No. 2 (the Telephone Company's Interstate Access Tariff) effective as of June 18, 2020, and any successive issues thereto. This tariff was filed with the FCC on behalf of the Telephone Company and affiliated companies.</p>			
<p>This tariff includes all the rules and regulations under which Interstate Access services will be offered. Exceptions to the adoption of the tariff schedules, if any, are as follows.</p>			
<p><b>B. <u>Terms and Conditions Exceptions</u></b></p> <p>None</p>			
<p><b>C. <u>Rates and Charges</u></b></p> <p>1. <i>Nonrecurring Charges</i></p> <p>a. Switched Access Service Ordering Charges and Design Change Charge</p> <table style="margin-left: 40px; width: 80%; border: none;"> <tr> <td style="text-align: center; width: 50%;"> <u>Switched Access Ordering Charge</u>  <u>Per ASR</u>                      \$100.00                 </td> <td style="text-align: center; width: 50%;"> <u>Design Change Charge</u>  <u>Per ASR</u>                      \$38.04                 </td> </tr> </table>	<u>Switched Access Ordering Charge</u> <u>Per ASR</u> \$100.00	<u>Design Change Charge</u> <u>Per ASR</u> \$38.04	
<u>Switched Access Ordering Charge</u> <u>Per ASR</u> \$100.00	<u>Design Change Charge</u> <u>Per ASR</u> \$38.04		
<p>b. 500 NXX Translation Charge</p> <table style="margin-left: 40px; width: 80%; border: none;"> <tr> <td style="text-align: center; width: 50%;"> <u>First NXX</u>  <u>Per ASR/per End Office</u>                      \$21.00                 </td> <td style="text-align: center; width: 50%;"> <u>Each Additional NXX</u>  <u>Per ASR/Per End Office</u>                      \$11.00                 </td> </tr> </table>	<u>First NXX</u> <u>Per ASR/per End Office</u> \$21.00	<u>Each Additional NXX</u> <u>Per ASR/Per End Office</u> \$11.00	
<u>First NXX</u> <u>Per ASR/per End Office</u> \$21.00	<u>Each Additional NXX</u> <u>Per ASR/Per End Office</u> \$11.00		
<p>c. Network Blocking Charge</p> <p style="text-align: center;"><u>Applies to FGB, FGC, FGD, BSA-B, BSA-C, BSA-D and SAC Access Service</u></p> <p style="text-align: center;"><u>Per Call</u> \$.016</p>			
<p>d. FGA and BSA-A Optional Toll Blocking</p> <p style="text-align: center;">Per FGA or BSA-A Line <u>Nonrecurring Charge</u> \$5.32</p>			

**V. SWITCHED ACCESS** (Continued)

e. 0+900 Service				
Per End Office <u>Nonrecurring Charge</u> \$300.00				
2. <i>Switched Transport</i>				
Regulations concerning switched access are set forth in Section V.A..				
a. Tandem Switching Rate				
	<u>Per Originating 8YY End Office Access Minute</u>	<u>Per Originating non- 8YY End Office Access Minute</u>	<u>Per Terminating 3<sup>rd</sup> Party Access Minute</u>	<u>Per Terminating Access Minute</u>
Zone 1	\$0.00433180	\$0.00433180	\$0.00000000	\$0.00433180
Zone 2	0.00433180	0.00433180	0.00000000	0.00433180
Zone 3	0.00433180	0.00433180	0.00000000	0.00433180
b. Shared Multiplexing				
Regulations concerning switched access are set forth in Section V.A..				
c. Interconnection Rate				
Regulations concerning switched access are set forth in Section V.A..				
d. Direct-Trunked Transport-Voiceband				
	<u>Per Airline Mile, Per Month</u>			
Price Band A	\$4.90			
Price Band B	4.90			
Price Band C	4.90			
N-MSA	4.90			

**V. SWITCHED ACCESS** (Continued)

e. Direct-Trunked Transport – DS1		
Direct-Trunked Transport-Facility – DS1 <u>Per Airline Mile, Per Month</u>	Direct-Trunked Transport-Termination – DS1 <u>Monthly Rate</u>	
Price Band A	\$8.67	\$26.00
Price Band B	11.83	35.46
Price Band C	14.91	44.72
Zone 1	7.88	23.64
Zone 2	10.75	32.24
Zone 3	13.55	40.65
f. Direct-Trunked Transport – DS3		
Direct-Trunked Transport-Facility – DS3 <u>Per Airline Mile, Per Month</u>	Direct-Trunked Transport-Termination – DS3 <u>Monthly Rate</u>	
Price Band A	\$43.40	\$432.91
Price Band B	54.18	547.80
Price Band C	60.00	585.00
Zone 1	39.45	393.55
Zone 2	49.25	498.00
Zone 3	60.00	585.00
End Office Dedicated Trunk Port Originating Voiceband <u>Monthly Rate, Per Channel</u>	End Office Dedicated Trunk Port Originating DS1 <u>Monthly Rate, Per Channel</u>	
\$28.75	\$12.50	
End Office Dedicated Trunk Port Terminating Voiceband <u>Monthly Rate, Per Channel</u>	End Office Dedicated Trunk Port Terminating DS1 <u>Monthly Rate, Per Channel</u>	
\$0.00	\$0.00	
g. Dedicated Trunk Port		
Access Tandem Dedicated Trunk Port Voiceband <u>Monthly Rate, Per Channel</u>	Access Tandem Dedicated Trunk Port DS1 <u>Monthly Rate, Per Channel</u>	
\$19.70	\$8.70	

**V. SWITCHED ACCESS** (Continued)

h. Entrance Facility – 2-Wire and 4-Wire Voiceband				
	<u>Service Installation Charge Per Entrance Facility</u>		<u>Entrance Facility – 2-Wire Voiceband Monthly Rate</u>	<u>Entrance Facility – 4-Wire Voiceband Monthly Rate</u>
Price Band A	\$200.00		\$29.45	\$45.94
Price Band B	200.00		29.45	45.94
Price Band C	200.00		29.45	45.94
N-MSA	200.00		29.45	45.94

i. Entrance Facility, per DS1		
	<u>Service Installation Charge</u>	<u>Monthly Rate</u>
Price Band A	\$450.00	\$275.00
Price Band B	450.00	302.50
Price Band C	450.00	330.00
Zone 1	450.00	250.00
Zone 2	450.00	275.00
Zone 3	450.00	300.00

j. Entrance Facility, per DS3				
	<u>Entrance Facility – DS3 Electrical Interface Service</u>		<u>Entrance Facility – DS3 Optical Interface</u>	
	<u>Service Installation Charge</u>	<u>Monthly Rate</u>	<u>Service Installation Charge</u>	<u>Monthly Rate</u>
Price Band A	\$1,000.00	\$1,188.00	\$750.00	\$810.00
Price Band B	1,000.00	1,292.38	750.00	913.59
Price Band C	1,000.00	1,750.00	750.00	1,125.00
Zone 1	1,000.00	1,080.00	750.00	810.00
Zone 2	1,000.00	1,174.89	750.00	913.59
Zone 3	1,000.00	1,750.00	750.00	1,125.00

### V. SWITCHED ACCESS

k. Multiplexing				
	<u>DS1 to Voice</u>		<u>DS3 to DS1</u>	
	<u>Service Installation</u>	<u>Monthly</u>	<u>Service Installation</u>	<u>Monthly</u>
	<u>Charge</u>	<u>Rate</u>	<u>Charge</u>	<u>Rate</u>
Price Band A	\$800.00	\$214.50	\$450.00	\$457.00
Price Band B	800.00	218.40	450.00	457.00
Price Band C	800.00	224.30	450.00	457.00
Zone 1	800.00	190.00	450.00	393.55
Zone 2	800.00	197.50	450.00	498.00
Zone 3	800.00	200.00	450.00	585.00
<b>3. End Office Services</b>				
a. Toll Free Data Base Query Charge				
0.002224				
b. End Office Switching – Bundled (EOSB)				
The unbundled rates for End Office Switching are based on originating and terminating Access Minutes.				
	<u>Per Originating 8YY</u>	<u>Per Originating Non-8YY</u>	<u>Per Terminating</u>	
	<u>Access Minute</u>	<u>Access Minute</u>	<u>Access Minute</u>	
	\$.00321064	\$.00642128	\$0.00	
c. End Office Switching – Unbundled (EOSU) – Circuit Switched Line				
The unbundled rates for End Office Switching are based on originating and terminating Access Minutes.				
	<u>Per Originating 8YY</u>	<u>Per Originating Non-8YY</u>	<u>Per Terminating</u>	
	<u>Access Minute</u>	<u>Access Minute</u>	<u>Access Minute</u>	
	\$.00321064	\$.00642128	\$0.00	
d. Shared Trunk Port				
Regulations concerning switched access are set forth in Section V..				
<b>4. Information Surcharge</b>				
The rates for Information Surcharge are based on originating and terminating Access Minutes. Regulations concerning switched access are set forth in Section V..				

### V. SWITCHED ACCESS

<p>5. <i>FGA or BSA-A Usage Sensitive Credit Allowance</i></p> <p style="text-align: center;">Usage Sensitive Service <u>Credit Allowance</u></p> <p style="text-align: center;"><u>Credit Per Originating FGA or BSA-A Access Minute</u><sup>5</sup></p> <p style="text-align: center;">\$.00099770</p>											
<p>6. <i>CCS7 Access Service – Dedicated Switched Access</i></p> <p>a. 56 Kbps Digital Facilities</p> <table style="width: 100%; border-collapse: collapse;"> <thead> <tr> <th style="text-align: center;"><u>Dedicated Switched Access Transport</u></th> <th colspan="2" style="text-align: center;"><u>Dedicated Switched Access Line</u></th> </tr> <tr> <th style="text-align: center;">(Per Airline Mile) <u>Monthly Rate</u></th> <th style="text-align: center;">Nonrecurring <u>Charge</u></th> <th style="text-align: center;"><u>Monthly Rate</u></th> </tr> </thead> <tbody> <tr> <td style="text-align: center;">\$2.44</td> <td style="text-align: center;">\$100.00</td> <td style="text-align: center;">\$83.33</td> </tr> </tbody> </table>			<u>Dedicated Switched Access Transport</u>	<u>Dedicated Switched Access Line</u>		(Per Airline Mile) <u>Monthly Rate</u>	Nonrecurring <u>Charge</u>	<u>Monthly Rate</u>	\$2.44	\$100.00	\$83.33
<u>Dedicated Switched Access Transport</u>	<u>Dedicated Switched Access Line</u>										
(Per Airline Mile) <u>Monthly Rate</u>	Nonrecurring <u>Charge</u>	<u>Monthly Rate</u>									
\$2.44	\$100.00	\$83.33									
<p>b. High Capacity Digital DS1 (1.544 Mbps) Facilities</p> <table style="width: 100%; border-collapse: collapse;"> <thead> <tr> <th style="text-align: center;"><u>Dedicated Switched Access Transport</u></th> <th colspan="2" style="text-align: center;"><u>Dedicated Switched Access Line</u></th> </tr> <tr> <th style="text-align: center;">(Per Airline Mile) <u>Monthly Rate</u></th> <th style="text-align: center;">Nonrecurring <u>Charge</u></th> <th style="text-align: center;"><u>Monthly Rate</u></th> </tr> </thead> <tbody> <tr> <td style="text-align: center;">\$8.57</td> <td style="text-align: center;">\$1,500.00</td> <td style="text-align: center;">\$224.09</td> </tr> </tbody> </table>			<u>Dedicated Switched Access Transport</u>	<u>Dedicated Switched Access Line</u>		(Per Airline Mile) <u>Monthly Rate</u>	Nonrecurring <u>Charge</u>	<u>Monthly Rate</u>	\$8.57	\$1,500.00	\$224.09
<u>Dedicated Switched Access Transport</u>	<u>Dedicated Switched Access Line</u>										
(Per Airline Mile) <u>Monthly Rate</u>	Nonrecurring <u>Charge</u>	<u>Monthly Rate</u>									
\$8.57	\$1,500.00	\$224.09									
<p>7. <i>CCS7 Access Service – STP Port Termination</i></p> <table style="width: 100%; border-collapse: collapse;"> <thead> <tr> <th style="text-align: center;">Nonrecurring <u>Charge</u></th> <th style="text-align: center;">Monthly <u>Rate</u></th> </tr> </thead> <tbody> <tr> <td style="text-align: center;">\$69.00</td> <td style="text-align: center;">\$280.28</td> </tr> </tbody> </table>			Nonrecurring <u>Charge</u>	Monthly <u>Rate</u>	\$69.00	\$280.28					
Nonrecurring <u>Charge</u>	Monthly <u>Rate</u>										
\$69.00	\$280.28										

<sup>5</sup> The credit is applied to the End Office Switching rate element.



**V. SWITCHED ACCESS** (Continued)

8. <i>Assumed Minutes of Use Monthly Surrogate</i>					
<u>Per Two Way Line/Trunk</u>		<u>Per One Way Line/Trunk</u>			
		<u>Originating Only</u>		<u>Terminating Only</u>	
<u>FGA or BSA-A</u>	<u>FGB or BSA-B</u>	<u>FGA or BSA-A</u>	<u>FGB or BSA-B</u>	<u>FGA or BSA-A</u>	<u>FGB or BSA-B</u>
6	6	6	6	6	6
9. <i>Switched Access Cross Connect</i>					
Rates and Charges					
	<u>DS0 Monthly Rate</u>		<u>DS1 Monthly Rate</u>		<u>DS3 Monthly Rate</u>
	\$2.10		\$4.90		\$37.57
10. <i>Basic Service Elements</i>					
a. <i>Alternate Traffic Routing – BSE</i>					
	<u>Nonpremium Nonrecurring Charge Per Trunk Group Equipped</u>		<u>Premium Nonrecurring Charge Per Trunk Group Equipped</u>		
	\$29.35		\$65.22		
b. <i>Automatic Number Identification (ANI) – BSE</i>					
	<u>Rate Per ANI Attempt</u>				
	\$0.00014				

<sup>6</sup> These jurisdictions either have all existing services measured or have no customers at this time. In the event an ASR is received for a new customer and there is no measurement capability for the office requested, a traffic study will be made to establish a surrogate and such surrogate will be tarified.

**V. SWITCHED ACCESS** (Continued)

c. User Transfer – BSE		
<u>Monthly Rates Per Line Arranged</u>		
\$1.50		
d. Hunt Group Arrangement – BSE		
<u>Nonpremium Monthly Rates Per Line Equipped</u>	<u>Premium Monthly Rates Per Line Equipped</u>	
\$1.35	\$3.00	
e. Queuing – BSE		
<u>Nonpremium Monthly Rates Per Group Equipped</u>	<u>Premium Monthly Rates Per Group Equipped</u>	
\$6.75	\$15.00	
f. Uniform Call Distribution – BSE		
<u>Nonpremium Monthly Rates Per Line Equipped</u>	<u>Premium Monthly Rates Per Line Equipped</u>	
\$2.19	\$4.86	
g. Simplified Message Desk Interface (SMDI) – BSE		
<u>Nonpremium Monthly Recurring Rate Per DNAL</u>	<u>Premium Monthly Recurring Rate Per DNAL</u>	
\$95.06	\$211.24	
h. Premier Messaging Services Interface (PMSI) – BSE		
	<u>Monthly Rate</u>	
Premier Messaging Service Interface BSE - Per Arrangement, Per Month	\$500.00	

**V. SWITCHED ACCESS** (Continued)

i. Signaling System 7 Message Waiting Indicator (SS7MWI) Signaling Service – BSE		
	<u>Monthly Rate</u>	
SS7MWI Signaling Service	\$500.00 per Messaging Arrangement	
j. Remote Call Forwarding – BSE		
<u>Nonpremium Monthly Recurring Rate Per Line</u>	<u>Premium Monthly Recurring Rate Per Line</u>	
\$7.20	\$16.00	
k. Direct Inward Dialing (DID) – BSE		
<u>Monthly Recurring Rate Per DID Term</u>	<u>Monthly Recurring Rate Per Block of 20 Numbers</u>	
\$25.00	\$10.00	
l. Billed Number Screening (BNS) – BSE		
<u>Monthly Recurring Rate Per Line Screened</u>		
\$0.00		
11. <i>Carrier Identification Parameter (CIP)</i>		
<u>Non-Recurring Charge-Per CIC, Per End Office Direct Trunk Group</u>	<u>Non-Recurring Charge Per CIC, Per Access Tandem Direct Trunk Group</u>	<u>Monthly Recurring Charges Per Trunk</u>
\$80.00	\$1,120.00	\$.46

## VI. SPECIAL ACCESS

<p><b>A. <u>General</u></b></p> <p>Special Access provides a transmission path to connect CDLs<sup>7</sup> within a LATA for Intrastate Telecommunications. Special Access provided to a customer may be connected directly to customer facilities, through Company Hub Wire Centers where bridging or multiplexing functions are performed, and/or may be connected to access facilities of another telephone company or companies in the joint provision of Special Access Service as well as may be connected to Switched Access as set forth in FCC Tariff No. 5. Special Access Services may also be connected to a customer's transmission equipment and facilities using a DS1 or DS3 Cross Connect arrangement where the customer is provided Expanded Interconnection Service (EIS) as defined in Section XIX.. Other types of arrangements, when feasible, will be addressed on an Individual Case Basis and filed in this tariff.</p>	
<p>The provision of Switched Access and Special Access in combination is normally for, but not limited to, the use of WATS or WATS-type Access. When Special Access is connected to Switched Access, the terms, conditions and rates for the facilities between the end user's CDL and the WATS Serving Office are set forth in this section of the tariff; the terms, conditions and rates for the facilities between the WATS Serving Office and the IC's CDL, as well as the switching functionalities (e.g., end user access codes, screening) are as set forth in Section V. of this tariff.</p>	
<p>Special Access can be provided in either analog or digital format. Analog formats are differentiated by spectrum and bandwidth. Digital formats are differentiated by bit rate. The specific types of Special Access (e.g., Voiceband, Wideband Data Service) provided are described in VI.B..</p> <p><b>1. <i>Rate Elements</i></b></p> <p>With the exception of Temporary Videoband Service, there are five basic rate elements which apply to Special Access Service:</p> <ul style="list-style-type: none"><li>Special Transport [described in VI.A.1.b.]</li><li>Special Transport Termination [described in VI.A.1.g.]</li><li>Special Access Line [described in VI.A.1.c.]</li><li>Supplemental Features (described in VI.D.)</li><li>Multiplexing Arrangements (described in VI.E.)</li></ul>	

---

<sup>7</sup> Company Centrex CO-like switches are considered to be CDLs for the purposes of this tariff.

## VI. SPECIAL ACCESS (Continued)

<p>The following is a list of the Company's Open Network Architecture (ONA) Special Access Basic Service Elements (BSEs), identified to date, which provide a cross-reference to the generic ONA product names.</p>	
<p><u>Generic Name</u></p> <p>Access to Clear Channel Transmission Automatic Protection Switching Bridging Conditioning Data Over Voice (DOV) Service Secondary Channel Capability Multiplexing - Digital 2000</p>	<p><u>Company Name</u></p> <p>Clear Channel Capability Automatic Protection Switching Bridging Conditioning DOV Connect Secondary Channel Multiplexing Arrangements</p>
<p>a. Special Transport</p>	
<p>(1) The Special Transport rate element provides for the transmission facilities between the serving wire centers associated with two (2) CDLs, between a serving wire center associated with an end user's CDL and a WATS Serving Office, between a serving wire center associated with a CDL and a Company Hub Wire Center or between two (2) Company Hub Wire Centers. Connection to Company provided DS1 or DS3 Special Transport within a serving wire center for customers with EIS will require a Special Access Cross Connect arrangement as described in <i>VI.A.1.d.</i></p>	
<p>The Special Transport element is distance sensitive and varies with type of capability (i.e., analog or digital) and type of facility (e.g., Voiceband, Wideband Data Service, etc.). Special Transport may be provided by more than one (1) telephone company. The method of calculating applicable airline miles for rating purposes for Special Access is specified in <i>III.G.</i></p>	
<p>(2) Special Transport may be used in conjunction with Switched Access for the purpose of provisioning Originating Only, Terminating Only or Combined Originating/Terminating Access as set forth in Section V.. Special Transport employed in this manner provides the FIA for the closed-end of the services between the wire center serving the end user's CDL where WATS Serving Office functions are not available and the WATS Serving Office.</p>	
<p>When the necessary WATS Serving Office functions are not provided at the wire center which serves the end user's CDL, the Company will designate the wire center where the WATS Serving Office functions are available.</p>	
<p>(3) For Fractional T1 (FT1) service, Special Transport must be ordered as Fractional Special Transport in the same grouping (N x 56 Kbps or N x 64 Kbps where N = 2, 4, or 6) as the associated FT1 SALs.</p>	
<p>b. Special Access Line (SAL)</p>	
<p>(1) A Special Access Line provides the transmission facilities to a CDL or the facilities between a CDL and the serving wire center. This rate element varies by type of capability (i.e., analog or digital) and type of facility (e.g., Voiceband, Wideband Data Service, etc.).</p>	

**VI. SPECIAL ACCESS** (Continued)

<p>When a Voiceband Special Access Service is ordered to be terminated at a customer's designated Interexchange Carrier's all digital CDL which requires a minimum digital interface of 1.544 Mbps, the Company will provide the required interface and assess the customer a Voiceband SAL, for the facility between the all-digital CDL and its serving wire center. All other appropriate charges apply in addition to the Voiceband SAL.</p>	
<p>SAL rates for DS3 offerings vary with the level of capacity, number of services and whether the interface provided is electrical or optical.</p>	
<p>Installation of DS1/DS3 SALs is in <i>VI.F.1.d.(5)</i>. The applicable rates are the nonrecurring charge and monthly rate per DS1/DS3 installed.</p>	
<p>The selection of a Terminating Option, as defined in <i>VI.C.</i>, is required for terminating the network portion of a Special Access Line at a CDL. Terminating Options provide a clearly delineated interface which facilitates the design, isolation and testing of the Special Access. For DS3 Special Access, the customer may specify either an electrical or optical interface as described in <i>IV.A.1.f.</i>. Optical interface is available as an ICB.</p>	
<p>One Special Access Line charge applies per CDL at which the facility is terminated. This charge applies even if the facilities to the CDL do not transit a serving wire center; this charge also applies even if the CDL and the serving wire center are co-located in a Company building. Connection to Company provided DS1 or DS3 SALs within a serving wire center for customers with EIS will require a Special Access Cross Connect arrangement as described in <i>VI.A.1.d.</i>. The Special Access Line charge used with a Switching Interface, as in (2), is applicable only for the transmission facilities between the end user's CDL and the serving wire center of that location.</p>	
<p>(2) A Special Access Line may be provided with FGA, FGB, FGC, FGD, BSA-A, BSA-B, BSA-C and BSA-D Switched Access Service for the purpose of Originating Only, Terminating Only or Combined Originating and Terminating Access as described in Section V.. A Switching Interface is required for the provision of this service as described in <i>V.B.5.u.</i>. The Special Access Line provides the closed-end of the dedicated facilities between an end user's CDL and its serving wire center. This serving wire center may or may not be a WATS Serving Office. In those instances when the serving wire center is not a WATS Serving Office Special Transport is applicable as described in <i>VI.A.1.b.</i> to the nearest Company WATS Serving Office.</p>	
<p>The Switched Access used with the Special Access Line provides various standard switching functionalities and optional arrangement as described in Section V..</p>	
<p>All Special Access Lines used with a Switching Interface are:</p> <ul style="list-style-type: none"> <li>- provided with dial pulse address signaling or Dual Tone Multifrequency (DTMF) address signaling and either loop start or ground start supervisory signaling. The type of signaling is the option of the customer.</li> </ul>	

**VI. SPECIAL ACCESS** (Continued)

<p>- available as either a two-wire or four-wire Voiceband Special Access Service (i.e., 300-3000 Hz bandwidth). Each transmission path is provided with standard transmission specifications as described in Section 7000 of the Industry Standard Technical Interface Reference Manual.</p>	
<p>All rules and regulations pertaining to Special Access are applicable to Special Access Lines used with a Switching Interface. Rates and charges for these services are found in VI.G.5. for two-wire and four-wire Voiceband Special Access Lines.</p>	
<p>A customer may also order high capacity facilities from an end user's CDL to a Company Hub for the purpose of originating or terminating Special Access Lines used with a Switching Interface. High capacity to voice multiplexing will be required at the Hub. The customer will be required to submit an ASR for the high capacity facility and voice multiplexing. The customer will also be required to submit an ASR(s) for the individual Voiceband SALs specifying the channel facility assignment (CFA) for each service. This Hub may or may not be a WATS Serving Office. In those instances when the Hub is not a WATS Serving Office, Voiceband Special Transport is applicable as set forth in VI.A.1.b., for each individual Special Access Line used with a Switching Interface to the Company designated WATS Serving Office.</p>	
<p>c. Special Access Line Cross connect</p> <p>The Special Access Cross Connect charge provides the communications path between Company provided DS1 or DS3 Special Access Lines or Special Transport and a customer's transmission equipment and facilities where the customer is provided EIS as defined in Section XIX.. The Cross Connect arrangement may connect directly to Company provided DS1 or DS3 services or to a Company provided DS1 or DS3 multiplexing arrangement. The Cross Connect charge applies per DS1 or DS3 connection. Rates for DS1 and DS3 Cross Connect arrangements are listed in VI.G.19..</p>	
<p>d. Supplemental Features</p> <p>Supplemental Features may be added to a Special Access circuit to improve its quality or utility to meet specific communications requirements. These are not necessarily identifiable with specific facilities, but rather represent the end result in terms of performance characteristics which may be obtained. These characteristics may be obtained by using various combinations of facilities. Although the facilities necessary to perform a specified function may be installed at various locations along the path of the Special Access circuit, including the CDL, it will be provided for as a single rate element.</p>	
<p>Examples of Supplemental Features that are available include, but are not limited to, bridging and conditioning. Each Supplemental Feature is described in VI.D. following, and rates are set forth in VI.G. following.</p>	

**VI. SPECIAL ACCESS** (Continued)

<p>e. Multiplexing Arrangements</p> <p>Multiplexing provides for arrangements to convert a single higher capacity or bandwidth circuit for bulk transport to several lower capacity or bandwidth circuits. Multiplexing is only available at a Company designated Hub Wire Center arranged for multiplexing. All types of multiplexing may not be available at each Hub Wire Center. Refer to Section VI.G.6. for a description of Hub Wire Center. Descriptions for each type of multiplexing arrangement are provided in VI.E. following, and rates are described in VI.G..</p>	
<p>f. Special Transport Termination</p> <p>(1) DS1, DS1C and DS3 (Individual and System) Service</p> <p>The Special Transport Termination rate element as described in VI.G.10., VI.G.11. and VI.G.18., applies only to DS1, DS1C, and DS3 (Individual and System) offerings and is in addition to the Special Transport rate element. Special Transport Termination provides the equipment and arrangements necessary to terminate the Special Transport facility at a serving wire center. One Special Transport Termination charge applies for the termination of each end of a Special Transport facility for DS1, DS1C, and DS3 (Individual and Systems) offerings.</p>	
<p>(2) Fractional T1 Service (FT1)</p> <p>For Fractional T1 Service, Special Transport Termination must be ordered as Fractional Special Transport Termination in the same grouping (N x 56 Kbps or N x 64 Kbps where N = 2, 4, or 6) as the associated FT1 SALs.</p>	
<p><b>2. Special Access Configurations</b></p> <p>There are two (2) types of facility configurations over which Special Access Services are provided: two-point and multipoint.</p> <p>a. Two-point Service</p> <p>A two-point configuration is a circuit which is provided to connect two CDLs, either directly connected or through a Hub Wire Center where multiplexing functions are performed, or a CDL and a WATS Serving Office.</p>	
<p>All Special Access offerings may be provided as a two-point configuration.</p>	
<p>With the exception of Temporary Videoband Service, applicable rate elements are:</p> <ul style="list-style-type: none"> <li>- Special Access Lines</li> <li>- Special Transport (when applicable)</li> <li>- Special Transport Termination (when applicable)</li> <li>- Supplemental Features (when applicable)</li> <li>- Multiplexing Arrangements (when applicable)</li> </ul>	

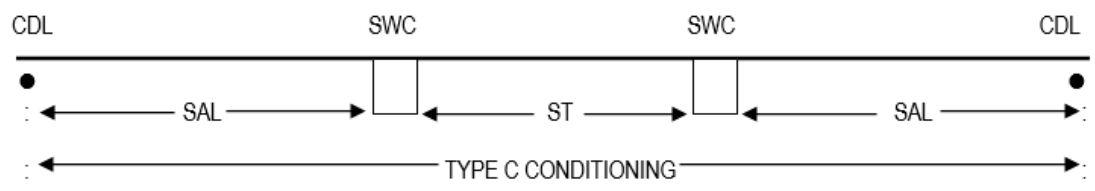

### VI. SPECIAL ACCESS (Continued)

<p>The following diagram depicts a typical two-point service connecting two CDLs. The service is provided with the supplemental feature of Type C Conditioning:</p>  <p>SAL - Special Access Line ST - Special Transport SWC - Serving Wire Center CDL - Customer Designated Location</p>	
<p>Applicable rate elements are:</p> <ul style="list-style-type: none"> <li>- Special Access Line (2 applicable)</li> <li>- Special Transport (per airline mile between SWCs)</li> <li>- Supplemental Feature of Type C Conditioning (2 applicable)</li> </ul>	
<p>b. Multipoint Service</p> <p>A multipoint configuration is a circuit that is provided to connect three (3) or more CDLs through a Company Hub Wire Center.</p>	
<p>Only Voiceband, Program Audio, and Digital Data Service facilities, and Miscellaneous Services where so designated, will be provided as multipoint configurations. There is no limitation on the number of mid-links, but the use of more than three (3) mid-links in tandem may degrade the quality of the multipoint facilities. A mid-link is defined as the Special Transport facilities between Hub Wire Centers where the circuit is bridged and/or where circuit switching devices, such as loop transfer arrangement, are located.</p>	
<p>Multipoint service is provided in the following manner:</p> <p>(1) Special Access Line per CDL to their respective serving wire centers.</p>	
<p>(2) Special Transport between serving wire centers associated with the CDLs and the Hub Wire Center.</p>	
<p>(3) Special Transport between Hub Wire Centers.</p>	
<p>(4) Supplemental Features: Bridging equipment for each bridging location and other Supplemental Features when applicable.</p>	
<p>(5) Multiplexing Arrangements when applicable.</p>	

### VI. SPECIAL ACCESS (Continued)

The following diagram depicts a multipoint service connecting four (4) CDLs via two (2) customer specified Hub Wire Centers:

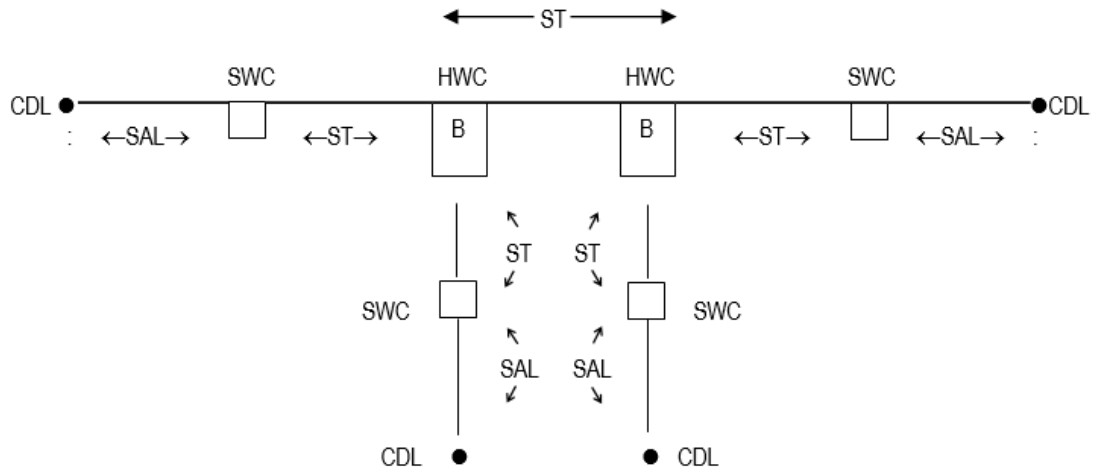

SAL - Special Access Line  
ST - Special Transport  
SWC - Serving Wire Center  
CDL - Customer Designated Location  
HWC - Hub Wire Center  
B - Bridging

Applicable rate elements are:

- Special Access Lines (4 applicable)
- Special Transport (5 segments, per airline between SWCs and HWCs)
- Bridging (6 applicable, one per bridge port)

#### 3. Special Facilities Routing

A customer may request that the facilities used to provide Special Access Service be specially routed. The regulations, rates and charges for Special Facilities Routing (i.e., Avoidance, Diversity and Cable-Only) are as set forth in Section X. following.

**VI. SPECIAL ACCESS** (Continued)

<p>4. <i>Design Layout Report</i></p> <p>The Company will provide to the customer the makeup of the Special Access provided under this tariff to aid the customer in designing its overall service. This information will be provided in the form of a Design Layout Report and will include the following:</p> <ul style="list-style-type: none"> <li>Cable gauge, length and loading.</li> <li>Makeup (e.g., T-Carrier, two-wire, four-wire, etc.)</li> <li>Specific pair of circuit assignment at the customer designated location.</li> </ul>	
<p>The Design Layout Report will be provided to the customer within fourteen (14) working days from the ASR Date. Updated reports will be reissued within fourteen (14) working days whenever facilities provided to the customer are materially changed. Both the initial and updated Design Layout Reports will be provided to the customer at no charge.</p>	
<p>5. <i>Acceptance Testing</i></p> <p>At the time of installation, the following test parameters apply:</p> <ul style="list-style-type: none"> <li>a. For Voiceband services, acceptance testing will include tests for loss, 3-tone slope, DC continuity, operational signaling, C-notched noise, and C-message noise.</li> </ul>	
<p>When the Interface Arrangement provides a four-wire voice transmission facility and the point of termination provides two-wire voice transmission (i.e., there is a four-wire to two-wire conversion at the point of termination) balance tests are also included in acceptance testing. When performing installation and acceptance testing, the Company will test the access service within the LATA.</p>	
<p>On four-wire and effective four-wire circuits where the Network Channel Terminating Equipment (NCTE) has the capability of being remotely aligned, the Company may perform acceptance testing without a Company technician at the customer's premise. Should the customer request a technician be present at the customer's premise, additional charges will apply as set forth in Section VII.B.3.. The applicable rates are in Section VII.B.6..</p>	
<p>If the NCTE at the customer's premise does not have the capability of being aligned remotely, the additional charges will not apply. The Company will determine the type of NCTE placed at a customer's premise.</p>	
<ul style="list-style-type: none"> <li>b. For other analog services (i.e., Program Audio, Video, Wideband Analog and Wideband Data Services) and for digital services (i.e., Digital Data Services and High Capacity Digital Services), acceptance testing will include tests for the parameters applicable to the service as set forth in Section 7000 of the Industry Standard Technical Interference Reference Manual for each of these service.</li> </ul>	
<p>When the customer requests the performance of additional cooperative tests which are not required to meet these specified performance parameters, charges as set forth in VII.F.2. will apply. All test results will be made available to the customer upon request.</p>	

**VI. SPECIAL ACCESS** (Continued)

<p>If acceptance tests are not started within fifteen (15) minutes after pre-service tests have been completed and the customer has been notified by the Company, additional charges may apply, as set forth in VII.B., unless the delay is caused by the Company.</p>	
<p><b>6. Ordering Conditions</b></p> <p>Ordering conditions are set forth in detail in Section IV.. Also included in that section, are other charges which may be associated with ordering Special Access (e.g., Service Date Change Charges, Cancellation Charges, etc.).</p> <p>a. Determination of Jurisdiction of Mixed Use Special Access Lines</p> <p>When mixed interstate and intrastate Special Access Service is ordered, the jurisdiction will be determined as follows:</p> <p>(1) If the customer's estimate of the interstate traffic on the service involved constitutes ten percent (10%) or less of the total traffic on that line, the line will be ordered and provided in accordance with the applicable rules and regulations of this tariff.</p>	
<p>(2) If the customer's estimate of the interstate traffic on the physically intrastate line involved constitutes more than ten percent (10%) of the total traffic on that line, the line will be ordered and provided in accordance with the applicable rules and regulations of the Company's interstate access tariff.</p>	
<p>(3) For lines in service on the effective date of this tariff, changes will be made in accordance with Section VI.F.1.d.(7). Existing customers will be allowed ninety (90) days from the effective date of this tariff to certify by letter the jurisdiction of the lines. The customer must submit an ASR for each line changing jurisdiction.</p>	
<p>(4) Lines in service on the effective date of this tariff certified to be jurisdictionally interstate and having a maximum termination liability associated with them will not be assessed the termination liability. The customer must submit an ASR for each line changing jurisdiction no later than ninety (90) days from the effective date of this tariff to have the termination liability waived.</p>	
<p>b. Special Access Jurisdictional Verification</p> <p>If a billing dispute arises or a regulatory commission questions the customer's certification of the jurisdiction of the line the Company will ask the customer to provide the data the customer used to determine the jurisdiction. The customer shall supply the data within thirty (30) days of the Company's request. The customer shall keep records of system design and functions from which the jurisdiction can be ascertained and upon request of the Company make the records available for inspection as reasonably necessary for purposes of verification of the jurisdiction of the service.</p>	

**VI. SPECIAL ACCESS** (Continued)

<p><b>B. <u>Description of Special Access</u></b></p> <p>There are seven (7) generic types of Special Access offerings. They are:</p> <ul style="list-style-type: none"> <li>- Voiceband</li> <li>- Program Audio</li> <li>- Videoband</li> <li>- Wideband Analog</li> <li>- Wideband Data</li> <li>- High Capacity Digital</li> <li>- Digital Data Service</li> </ul>	
<p>Each type has its own characteristics, and are subdivided by one or more of the following:</p> <ul style="list-style-type: none"> <li>- Transmission specifications</li> <li>- Bandwidth</li> <li>- Speed (i.e., bit rate)</li> <li>- Spectrum</li> </ul>	
<p>The Special Access offerings described below are comprised of a combination of the rate elements described in VI.A.1.. The following descriptions indicate the most effective use for each facility. Customer use for purposes other than those indicated is limited only to the extent that such use must not harm the network. Further, the Company does not guarantee transmission performance beyond the parameters identified in the descriptions.</p>	
<p>The transmission performance characteristics of each Special Access offering are stated in Section 7000 of the Industry Standard Technical Interface Reference Manual. The Company will maintain existing transmission specifications on services installed prior to the effective date of this tariff, except that existing services with performance specifications exceeding the standards in the Industry Standard Technical Interface Reference Manual will be maintained at the performance level specified in the manual. Where transmission performance characteristics are required other than those as stated in Section 7000 of the Industry Standard Technical Interface Reference Manual, the Company will review, and where technically feasible, will develop rates and charges for the additional costs associated with provisioning the parameters. These rates and charges will be filed on an individual case basis in Section VI.I. and will apply in addition to all other applicable rates and charges.</p>	
<p>The customer also has the option of ordering Voiceband and analog and digital high capacity facilities to a Company Hub for multiplexing to individual channels of a lower capacity or bandwidth. Descriptions of the types of multiplexing available at the Hubs, as well as the number of individual channels which may be derived from each type of facility, are set forth in VI.E.. Additionally, the customer may specify supplemental features for the individual channels derived from the facility to further tailor the channel to meet specific communications requirements. Descriptions of the supplemental features available are set forth in VI.D..</p>	

## VI. SPECIAL ACCESS (Continued)

<p>For example, a customer may order a DS3 facility from a CDL to a Company Hub for multiplexing to twenty-eight (28) DS1 channels. The DS1 channels may be further multiplexed at the same or a different Hub to Voiceband channels or may be extended to other CDLs. Optional features may be added to either the DS1 or the Voiceband Channels.</p> <p>1. <i>Voiceband</i></p> <p>a. Two-Wire Voiceband Facility</p> <p>These facilities are unconditioned and are capable of transmitting voice or data signals within the frequency spectrum of approximately 300 Hz to 3000 Hz. These facilities are furnished on a two-point or multipoint basis and may be terminated two-wire or four-wire at the point of termination. They permit the simultaneous transmission of information in both directions over a circuit, but it is not possible to ensure independent information transmission in both directions. Supplemental features may be added, at applicable charges, to enhance the operational capabilities of these facilities.</p>	
<p>b. Four-Wire Voiceband Facility</p> <p>These facilities are unconditioned and are capable of transmitting voice or data signals within the frequency spectrum of approximately 300 Hz to 3000 Hz. The facilities are furnished on a two-point or multipoint basis and may be terminated two-wire or four-wire at the point of termination. When terminated four-wire, they permit simultaneous independent transmission of information in both directions over a circuit. However, when terminated two-wire, simultaneous independent transmission cannot be supported. Supplemental features may be added, at applicable charges, to enhance the operational capabilities of these facilities.</p>	
<p>2. <i>Program Audio</i></p> <p>These facilities are arranged and provided for the transmission of non-broadcast audio which is used in connection with loudspeakers, wired music, closed circuit, or recordings. Facilities to be used in connection with broadcast audio must be ordered from the appropriate interstate tariff. Audio facilities are furnished for transmission in one direction. Audio facilities may be provided on a two-point or multi-point basis.</p>	
<p>Program audio facilities are provided on either a full-time or part-time basis. The minimum periods for full-time and part-time service are set forth in <i>IV.B.4.</i>, preceding. When a part-time program audio service is provided for ten or more consecutive days it will be treated as a full-time service and rated accordingly. In no event will the charge for continuous part-time program audio exceed the amount that would have been charged in the same time period for full-time program audio facilities.</p>	
<p>Listed below are the types of Program Audio facilities that are offered under this tariff.</p> <p>a. 200 to 3500 Hz</p> <p>Facilities are generally acceptable for speech quality programming and are subject to use over limited distance due to transmission factors.</p>	

**VI. SPECIAL ACCESS** (Continued)

<p>b. 100 to 5000 Hz</p> <p>Facilities are generally acceptable for music and provide good quality speech programming.</p>	
<p>c. 50 to 8000 Hz</p> <p>Facilities for the provision of high fidelity music transmission.</p>	
<p>d. 50 to 15000 Hz</p> <p>Facilities for the provision of high fidelity music transmission. Two (2) such facilities may be conditioned, at applicable charges, for stereo operation.</p>	
<p>3. <i>Videoband</i></p> <p>Videoband facilities are arranged and provided for the transmission of television which is to be used other than for broadcast purposes in connection with viewing or recording. Facilities to be used in connection with broadcast video services must be ordered from the appropriate interstate tariff.</p>	
<p>The facilities are furnished for two (2) point transmission in one direction only of United States 525 line/60 field standard monochrome and National Television Systems Committee (NTSC) color television baseband video signals and the associated audio signals.</p>	
<p>Videoband Service are provided on a full-time or part-time (temporary) basis. The minimum periods are set forth in <i>IV.B.4.</i> and <i>IV.B.5.</i>. The monthly rates and nonrecurring charges for full-time Videoband Service will be developed on an Individual Case Basis. The hourly rates and nonrecurring charges for temporary service are those set forth in <i>VI.F.8.</i> and <i>VI.G.1.</i>.</p>	
<p>There is a maximum monthly charge that may be assessed to any temporary Videoband Service as described in <i>VI.F.1.c.</i>.</p>	
<p>Technician Standby is a nonoptional arrangement furnished only in conjunction with temporary Videoband Service. Technician Standby provides for Company monitoring of the temporary Video broadcast to ensure satisfactory transmission. The Company will determine the location of the video technician. At the option of the customer, additional technicians will be made available during the temporary Video broadcast; the customer will be assessed the Technician Standby charge for each additional technician.</p>	
<p>A customer may request (as an option) an active, alternate temporary Videoband transmission path for use in the event that the primary service becomes inoperative. This is referred to as a "hot standby" facility. The charge for this additional service will be the nonrecurring charges set forth in <i>VI.G.1.</i> following, and hourly rates set forth in <i>VI.F.5.</i> and <i>VI.G.1.</i> following for Temporary Videoband Facilities. Technician Standby charges are not applicable to the "hot standby" facility.</p>	

**VI. SPECIAL ACCESS** (Continued)

<p>4. <i>Wideband Analog</i></p> <p>These facilities are two (2) point and are furnished between CDLs or between a CDL and a Company designated Hub Wire Center where multiplexing is offered. The three (3) types of Wideband Analog facilities are:</p> <p>a. Group band facilities with a bandwidth from 60 kHz to 108 kHz for the transmission of a 12 circuit frequency division multiplexer (FDM) group.</p>	
<p>b. Supergroup band facilities with a bandwidth from 312 kHz to 552 kHz for the transmission of a 60 circuit FDM supergroup.</p>	
<p>c. Mastergroup band facilities with a bandwidth from 564 kHz to 3084 kHz for the transmission of a 600 circuit FDM mastergroup.</p>	
<p>5. <i>Wideband Data Service</i></p> <p>These analog facilities are arranged and furnished for two-point simultaneous two-way transmission of high speed data between two (2) CDLs. These facilities are normally utilized for the following data speeds: 19.2 kbps, 50 kbps, 56 kbps and 230.4 kbps.</p>	
<p>6. <i>High Capacity Digital</i></p> <p>These facilities are two (2) point and are furnished between CDLs or between a CDL and a Company designated Hub Wire Center where multiplexing is offered. High Capacity facilities may be used to provide Special Access Lines as set forth in VI.A.1.c.(2). A High Capacity Voice Multiplexing Arrangement, as described in VI.E., is required at the Hub Wire Center. High Capacity DS1 and DS3 services may also be connected to customer transmission equipment and facilities where the customer is provided EIS as defined in Section XIX..</p> <p>a. DS1 facilities provide for the transmission of isochronous bipolar serial data at a rate of 1.544 Mbps.</p>	
<p>b. DS1C facilities provide for the transmission of isochronous bipolar serial data at a rate of 3.152 Mbps.</p>	
<p>c. FT1 facilities are furnished for the transmission of isochronous bipolar serial data and are available at transmission rate groupings of N x 56 Kbps or N x 64 Kbps where N equals 2, 4, or 6. FT1 channels are contiguous within the network and can be used to create a wideband circuit using customer provided equipment. When N x 64 FT1 is ordered in conjunction with DS1 service for multiplexing purposes, the DS1 must have Clear Channel Capability as described in VI.H.1.. FT1 Service at a rate of N x 64 Kbps will only be provided where Clear Channel Capability is available in the network. Where Clear Channel Capability is not available, N x 56 Kbps service can be provided in lieu of N x 64 Kbps.</p>	



**VI. SPECIAL ACCESS** (Continued)

<p>d. Fiber Connect service facilities, which are only available as an OPP, provide for the transmission of an isochronous serial data stream at a rate of 6.312 Mbps, encoded and converted to a signal suitable for optical transport. Fiber Connect service is transmitted on fiber optic cable. When Fiber Connect is provided with a fiber optic interface at the CDL, a single transmission channel is provided with a data rate dependent on the Company fiber optic terminal equipment used to provision the facility. When Fiber Connect is provided with an electrical interface, four transmission channels of 1.544 Mbps each are provided at the interface.</p>	
<p>Fiber Optic Interface denotes the termination of service with single mode fiber optic cable at the customer premises. When this interface is selected, it is the customer's responsibility to provide the optical line termination at his premises. This equipment must be compatible with the Company provided equipment.</p>	
<p>Fiber Connect is offered only on a protected basis between a CDL and its serving wire center. Fiber Connect is not available with multipoint services. Special Transport between serving wire centers for Fiber Connect must be ordered as four (4) DS1s.</p>	
<p>e. DS3 facilities provide for the transmission of isochronous bipolar serial data at a rate of 44.736 Mbps. The Company will provide either an electrical or an optical interface with the service unless otherwise specified by the customer. Ordering conditions are set forth in <i>IV.A.1.f.</i> EIS is not available with DS3 services provided with an optical interface.</p>	
<p>f. DS3C facilities provide for the transmission of isochronous bipolar serial data at a rate of 89.472 Mbps. The Company will provide an optical interface with this service unless the service is provided via microwave, in which case an electro-magnetic interface is provided, or unless the customer requests an electrical interface.</p>	
<p><b>7. Digital Data Service</b></p> <p>Facilities for Digital Data Service are furnished for the simultaneous two-way transmission of synchronous data and are available at transmission speeds of: 2.4 Kbps, 4.8 Kbps, 9.6 Kbps, 19.2 Kbps, 56 Kbps or 64 Kbps. Digital Data facilities may be provided on a two-point or multipoint basis.</p>	
<p><b>8. Miscellaneous Special Access Services</b></p> <p>A description of each service provided under Miscellaneous Special Access Services, is found in <i>VI.H.</i> and the rates are in <i>VI.H.1.</i> Other Special Access rate elements may apply in addition to those found in <i>VI.H.1.</i></p>	

**VI. SPECIAL ACCESS** (Continued)

<p><b>C. <u>Description of Terminating Options</u></b></p> <p>Terminating Options provide a clearly delineated interface between Company and customer facilities at the point of termination at the CDL. Terminating Options facilitate the design, isolation, and testing of the Special Access. The description of each Terminating Option defines the most effective use of the Terminating Option. The technical parameters of each type of associated interface are set forth in Section 7000 of the Industry Standard Technical Interface Reference Manual. Although a customer is not restricted from alternate applications, except where such application is harmful to the network, the Company cannot guarantee technical performance for other than the applications stated below. Terminating Options are nonchargeable.</p>	
<p>1. <i>Narrowband</i></p> <p>a. 0 to 75 Baud Type 1</p>	<p>Provides standard open/closed 20 or 62 Ma energized interface to customer terminal equipment and converts customer terminal equipment signals to voice frequency signaling for transmission over two-wire and four-wire voiceband network facilities suitable for voice grade to narrowband multiplexing. This terminating option is obsolete and is limited to those circuits so equipped and in service as of October 25, 1991.</p>
<p>b. 0 to 75 Baud Type 2</p>	<p>Provides two-wire or four-wire metallic interface for customer or Company energized circuits. Company energized circuits are only available in conjunction with voice grade to narrowband multiplexing. This option does not guarantee dc current operation over special transport facilities. This terminating option is obsolete and is limited to those circuits so equipped and in service as of October 25, 1991.</p>
<p>c. 0 to 150 Baud</p>	<p>Provides standard RS-232C interface to customer terminal equipment and converts customer terminal equipment signals to voice frequency signaling for transmission over two-wire or four-wire voiceband facilities. This terminating option is obsolete and is limited to those circuits so equipped and in service as of October 25, 1991.</p>
<p>2. <i>Voice Grade</i></p> <p>a. Two-Wire Voice Grade, Non-Data, Without Signaling</p>	<p>This option provides a two-wire interface to a customer and terminates an effective two-wire facility furnished for voice transmission only. Customer provided signaling must be limited to tones in the voiceband. Customer provided voiceband signaling equipment must limit transmission power to 0.0 dBm peak and -13 dBm average power over a three (3) second period.</p>

**VI. SPECIAL ACCESS** (Continued)

<p>b. Four-Wire Voice Grade, Non-Data, Without Signaling</p> <p>This option provides a four-wire interface to customer terminal equipment and terminates an effective four-wire facility furnished for voice transmission only. Customer provided signaling must be limited to tones in the voiceband. Customer provided voiceband signaling equipment must limit transmission power to 0.0 dBm peak and -13 dBm average power over a three (3) second period.</p>	
<p>c. Voice Grade Data Termination</p> <p>This option provides a two-wire or four-wire transmission interface to a customer's private line data modem and terminates an effective four-wire facility furnished for voiceband data transmission.</p>	
<p>d. Two-Wire Voice Grade Station Connecting Facility Termination</p> <p>This option provides a means to terminate an effective two-wire facility or an effective four-wire facility with a two-wire customer interface on a telephone, key system, PBX, ACD, or similar equipment. This option is normally used to terminate facilities that furnish foreign central office service, the station end of PBX off premises service, or private switched service network access lines. The option provides both the transmission and loop signaling functions normally associated with these services. The option is also used to terminate facilities arranged with automatic ringdown signaling. This option provides the loop and ringdown signaling with the facility.</p>	
<p>e. Four-Wire Voice Grade Station Connecting Facility Termination</p> <p>A terminating option similar to <i>d.</i> used to terminate effective four-wire foreign central office service. The option provides a four-wire transmission interface to the customer terminal equipment and the loop signaling function normally associated with these services. This option provides the loop and ringdown signaling with the facility.</p>	
<p>f. Two-Wire Station Connecting Facility Termination for the Open End of an Off Premises PBX Extension</p> <p>Terminating options are available depending on the signaling range of the PBX (or similar system) as defined in 47 CFR § 68.1 et al. Type 1 is an option requiring range extension equipment at the CDL. Type 2 is an option with no range extension equipment at the CDL. If needed, the loop signaling range equipment for Type 1 must be specifically specified, see Section VI.D.4. for available arrangements.</p>	
<p>g. Dial Repeating Tie Trunk Termination</p> <p>Two network terminating options are provided for terminating effective four-wire transmission facilities used to furnish dial repeating tie trunk services. These options are described in terms of the interface they provide to a PBX (or similar system).</p> <p>(1) A Type I tie line termination provides the customer with a two-wire transmission interface and includes either two-wire or four-wire E&amp;M type signaling. Transmission and signaling interface options available are described in 47 CFR § 68.1 et al. This option provides the E&amp;M type signaling with the facility.</p>	

**VI. SPECIAL ACCESS** (Continued)

<p>(2) A Type III tie line termination provides the customer with a four-wire transmission interface and includes either two-wire or four-wire E&amp;M type signaling. Transmission and signaling options available are described in 47 CFR § 68.1 et al. This option provides the E&amp;M signaling with the facility.</p>	
<p>3. <i>Program Audio</i></p> <p>a. 200 to 3500 Hz</p> <p>Provides standard program audio interface levels and impedance matching to two-wire network facilities.</p>	
<p>b. 100 to 5000 Hz, 50 to 8000 Hz, and 50 to 15000 Hz</p> <p>Provides standard program audio interface levels, circuit equalization and impedance matching to two-wire network facilities.</p>	
<p>4. <i>Videoband</i></p> <p>Provides a Videoband Special Access Line interface for use in providing the one way transmission of video signals.</p>	
<p>Standard Videoband service is provided via one signal (combined video and audio). This signal is in the 30 Hz to 6.6 MHz frequency range. It includes a one-way diplexed transmission of standard 525 lines/60 fields monochrome or NTSC color video signal, and one (1) or two (2) associated 15 KHz audio signal.</p>	
<p>As an option, the customer may select to receive Videoband service via two (2) or three (3) signals (one (1) video and one (1) or two (2) audio). Under this option, the signal received will be in the 30 Hz to 4.5 MHz frequency range and the one (1) or two (2) audio signals will be in the 50 Hz to 15000 Hz frequency range.</p>	
<p>5. <i>Wideband Data Service</i></p> <p>Provides a Wideband Data Service Special Access interface for use in providing two-way transmission of sequential synchronous or nonsynchronous data at rates of 19.2, 50 or 230.4 kbps; or sequential synchronous bipolar data signals at a rate of 56 kbps over four-wire facilities.</p>	
<p>6. <i>High Capacity Digital</i></p> <p>a. High Capacity Digital DS1</p> <p>Provides a High Capacity Digital DS1 Special Access interface for use in providing simultaneous two-way transmission of isochronous bipolar serial data signals at the rate of 1.544 Mbps.</p>	

**VI. SPECIAL ACCESS** (Continued)

<p>b. High Capacity Digital DS1C</p> <p>Provides a High Capacity Digital DS1C Special Access interface for use in providing simultaneous two-way transmission of isochronous bipolar serial data signals at the rate of 3.152 Mbps.</p>	
<p>c. Fractional T1 Service</p> <p>Provides a DS1 Special Access interface for use in providing simultaneous two-way transmission of isochronous bipolar serial data signals and is limited to groupings of N x 56 Kbps or N x 64 Kbps where N equals 2, 4, or 6.</p>	
<p>d. Fiber Connect Service</p> <p>Provides a High Capacity Digital Special Access interface for use in providing simultaneous two-way transmission of isochronous bipolar serial data. The Company, at the option of the customer, will provide either an electrical or a fiber optic interface. The electrical interface option provides four electrical channels at 1.544 Mbps each. The fiber optic interface option is provided on a single mode fiber and terminates on fiber optic connectors. The 6.312 Mbps signal will be made up of four transmission channels of 1.544 Mbps each and will be encoded to an optical data rate dependent on the fiber optic terminal equipment used by the Company to provision the facility. When the optical interface is selected, it is the customer's responsibility to provide the optical line termination at his premises. This equipment must be compatible with the equipment provided by the Company. Service will be provided on a one for one protected basis only.</p>	
<p>e. High Capacity Digital DS3</p> <p>Provides a High Capacity Digital DS3 Special Access interface for use in providing simultaneous two-way transmission of isochronous bipolar serial data signals at the rate of 44.736 Mbps. The Company will provide either an electrical or an optical interface with the service unless otherwise specified by the customer. EIS is not available with DS3 services provided with an optical interface. Ordering conditions are found in <i>IV.A.1.f.</i></p>	
<p>f. High Capacity Digital DS3C</p> <p>Provides a High Capacity Digital DS3C Special Access interface for use in providing simultaneous two-way transmission of isochronous bipolar serial data signals at the rate of 89.472 Mbps. The Company will provide an optical interface with this service unless the service is provided via microwave, in which case, an electromagnetic interface is provided, or unless the customer requests an electrical interface.</p>	
<p><b>7. Digital Data Service (DDS)</b></p> <p>Provides DDS Special Access interface for use in providing simultaneous two-way transmission of sequential bipolar data signals at transmission speeds of 2.4 Kbps, 4.8 Kbps, 9.6 Kbps, 19.2 Kbps, 56 Kbps or 64 Kbps over four-wire facilities.</p>	

**VI. SPECIAL ACCESS** (Continued)

<p><b>D. <u>Description of Supplemental Features</u></b></p> <p>Supplemental Features are items which can be added to a Special Access service to provide enhanced capabilities or improve its utility. References to specific uses or Special Access types indicate the most effective use for each Supplemental Feature. Customer use for other purposes or with other Special Access types is limited only to the extent that such use must not harm the network. Further, the Company does not guarantee functional operation of Supplemental Features for these alternate applications.</p>	
<p>Listed below are the Supplemental Features that are offered under this tariff.</p> <p>1. <i>Bridging</i></p> <p>Bridging is the function of connecting three (3) or more CDLs in a multipoint arrangement. Listed below are those bridging services offered under this tariff.</p> <p>a. MultiPoint Data Bridging</p> <p>This feature provides the capability to derive a multipoint data circuit from a single facility and is normally provided on Voiceband facilities provided for transmission of data signals. This function is provided on a per port basis. Polled multipoint data circuits are a typical application of this feature.</p>	
<p>b. Voice Conference Bridging</p> <p>Bridging arrangement to connect multiple Voiceband facilities in order that a voice frequency input signal from any location will be reproduced at the output of all other circuit locations. This function is provided on a per port basis.</p>	
<p>c. Alarm Distribution Bridging</p> <p>Provides polling type bridging capabilities, band splitting filters and conversion of four-wire common terminations up to a capacity of forty (40) two-wire terminations. This function is offered as two (2) tariff elements. The first element provides all shelving and common equipment for a capacity of forty (40) two-wire terminations. The second element provides a two-wire port. One common equipment rate element will apply to accommodate up to forty (40) two-wire terminations. One (1) two-wire port charge will apply to each two-wire Special Access Line terminated in the bridge.</p>	
<p>d. Program Audio Bridging</p> <p>An arrangement to provide multiple channel outputs from a single Program Audio or Voiceband facility. This arrangement is provided on a per port basis.</p>	

**VI. SPECIAL ACCESS** (Continued)

<p>e. Dataphone Select-A-Station Bridging</p> <p>Provides for the connection of a master station location to a number of remote stations. The capacity of this bridging arrangement will vary from a minimum of twenty-one (21) stations to a maximum of eighty-four (84) stations dependent upon the mixture of four-wire and two-wire ports equipped. Charges consist of a rate for either common equipment-addressable or common equipment-sequential, plus a rate for each four-wire port connected or for each two-wire port connected.</p>	
<p>f. DDS Bridging</p> <p>Provides for a multi-junction unit (MJU) arrangement to bridge 2.4 kbps, 4.8 kbps, 9.6 kbps, or 56 kbps DDS facilities. Different speeds cannot be mixed on the same bridge. This function is provided on a per port basis.</p>	
<p><b>2. Conditioning Arrangements – Data</b></p> <p>Data conditioning, when utilized in conjunction with effective four-wire Voiceband transmission facilities, improves the characteristics of these facilities. These improved characteristics are not represented to apply to the entire end to end facility of the customer, but only to that portion of the facility provided by the Company.</p>	
<p>There are two types of data conditioning: Type C and Type DA. Type C conditioning controls attenuation distortion and envelope delay distortion. Type DA controls the signal to C-notched noise ratio and intermodulation distortion. Type C and Type DA conditioning may be combined on the same circuit.</p>	
<p>Data conditioning is charged for on a per Special Access line basis. The parameters listed for each type of data conditioning apply from two (2) or more CDLs located within the Company serving area. Conditioning parameters apply to each end of a two-point circuit. For multipoint circuits, the conditioning parameters apply from any CDL to either the point of interface at another CDL or the first Company bridging point depending on the circuit configuration. These parameters are not applicable to High Capacity or Wideband Analog points of interface, because there is no voice frequency test access point. In these instances the data conditioning parameters apply to the last Company voice frequency test access point before the High Capacity or Wideband Analog point of interface.</p> <p>a. Type C</p> <p>Type C conditioning of Voiceband facilities provides a facility with the following transmission parameters enhanced to meet the values specified for Type C conditioning in Section 7000 of the Industry Standard Technical Interface Reference Manual in addition to the standard parameters for Voiceband circuits.</p> <p>(1) Attenuation distortion with reference to 1004 Hz.</p>	
<p>(2) Envelope delay distortion.</p>	

**VI. SPECIAL ACCESS** (Continued)

<p>b. Type DA</p> <p>Type DA conditioning of Voiceband facilities provides a facility with the following transmission parameter enhanced to meet the values specified for Type DA Conditioning in Section 7000 of the Industry Standard Technical Interface Reference Manual in addition to the standard parameters for voiceband circuits.</p> <p>(1) Signal to C-notched noise ratio.</p>	
<p>(2) Nonlinear signal to second order distortion.</p>	
<p>(3) Nonlinear signal to third order distortion.</p>	
<p>3. <i>Conditioning – Program Audio</i></p> <p>a. Stereo Conditioning</p> <p>Provides the option of two (2) radio program facilities which are identical in all transmission characteristics. Two Program Audio facilities are required to provide this Supplemental Feature. This feature is normally used only with Program Audio 50 to 15000 Hz facilities. Stereo Conditioning is charged on a per occurrence basis.</p>	
<p>b. Zero Loss</p> <p>Conditioning of Program Audio facilities to provide zero loss at 1000 Hz test frequency. Zero Loss is charged on a per Special Access Line basis.</p>	
<p>4. <i>Signaling Arrangements</i></p> <p>Signaling arrangements, when furnished with Voiceband transmission facilities, enable the facilities to accommodate standard telecommunications signaling protocols. Signaling arrangements provide for the conversion of one signaling method to another signaling method and/or extension of a signaling method at customer and Company interfaces and enables the transmission facilities to accommodate signaling transmission. Signaling arrangements are available with Voiceband transmission facilities to enable transmission of requested signaling formats. The third and fourth protocol characters of the Network Channel Interface (NCI) and Secondary Network Channel Interface (SEC NCI) codes as indicated on the customer's order, reflect signaling activity. Typical protocol characters contained in the NCI or SEC NCI es that designate signaling arrangements are: AB, AC, DS, DX, DY, EA, EB, EC, EX, GO, GS, LA, LB, LC, LO, LR, LS, NO, RV and SF.</p>	
<p>The customer identified NCI and SEC NCI codes will be considered the customer's request for signaling. The Company will endeavor to provide the specific signaling protocols requested by the customer. In those cases where facilities and equipment are not available to meet the customer's specific requests, the Company will provide the customer acceptable alternate protocols. Sections 3300, 6000 and 7000 of the Industry Standard Technical Interface Reference Manual provide detailed technical descriptions of the signaling protocols normally available with each service offering. To properly provision SF signaling, when associated signaling code is DS (PCM), additional information of SF requirements (loop signaling type DX/E&amp;M or ringdown) must accompany the customer's order.</p>	



**VI. SPECIAL ACCESS** (Continued)

<p>Signaling arrangement charges apply whenever interfaces at the customer premises or at the customer's Company serving wire center require a signaling arrangement other than those provided with the Terminating Options in VI.C.2. preceding. Signaling Arrangements will be charged on a per SAL basis. Specifically, a signaling charge applies if the signaling protocol characters in the NCI and the SEC NCI fields are different and include on the following codes: RV, EX, SF, DX, DY, DS, AB.</p>	
<p>For the above conditions, one additional signaling charge applies for each additional leg of multipoint circuit. When a Multiplexing Arrangement is ordered that converts a single higher capacity or bandwidth circuit into several lower Voiceband circuits, the Voiceband Signaling Arrangements are provided as part of the Multiplexing Arrangement, and no additional Signaling Arrangement charges will apply.</p>	
<p>A signaling charge applies in addition to any other applicable signaling charge when loop range extension equipment is required. The Company will obtain customer approval for signaling range extension equipment.</p>	
<p>Listed below are the Signaling Arrangements offered under this tariff:</p> <p>a. Loop Signaling Range Extension - An arrangement to extend the metallic resistance limitations of loop type signaling.</p>	
<p>b. Conversion of Loop or E&amp;M Signaling to SF - An arrangement to convert loop or E&amp;M signaling to the single frequency signaling format.</p>	
<p>c. E&amp;M to DX Signaling Conversion - Conversion of E&amp;M signaling to the DX signaling format.</p>	
<p>d. E&amp;M to Loop Signaling Conversion - Conversion of E&amp;M signaling format to the loop type signaling.</p>	
<p>e. Loop or E&amp;M to PCM Signaling - Conversion of loop or E&amp;M signaling to the digital (PCM) signaling format.</p>	
<p>f. Automatic Ringdown Signaling (ARD) - A signaling arrangement on a two-point Special Access which converts loop seizure at one end of the facility into ringing signal at the opposite end.</p>	
<p>5. <i>Echo Control</i></p> <p>a. Echo Suppression</p> <p>An arrangement provided at the customer's request to attenuate reflected speech energy on a four-wire facility. This conditioning is generally required on circuits with long propagation delay. Echo suppression is charged on a per Special Access circuit basis. Echo suppression is an obsolete service offering and is applicable only to those circuits equipped with echo suppression prior to January 1, 1987. Any service rearrangements or order activity on the circuits equipped with echo suppression may require a change to echo canceller as described in VI.D.5.b. following.</p>	

**VI. SPECIAL ACCESS** (Continued)

<p>b. Echo Cancellor</p> <p>An arrangement provided at the customer's request to cancel reflected speech energy on a four-wire facility. This conditioning is generally required on circuits with long propagation delay. Echo canceller is charged on a per Special Access circuit basis.</p>	
<p>6. <i>Improved Return Loss</i></p> <p>Improved Return Loss provides for increased echo return and singing return parameters of an effective two-wire channel. This optional feature is available with certain Voiceband services at a two-wire point of termination when the transmission interface is four-wire at one CDL and two-wire at the other CDL. Placement of Company equipment may be required at the customer's premises with the two-wire point of termination.</p>	
<p>Improved Return Loss rates and charges will apply on a per Special Access Line basis at the rates specified in VI.G.5.. Technical parameters and the applicable Voiceband services are specified in Section 7000 of the Industry Standard Technical Interface Reference Manual.</p>	
<p>7. <i>Voiceband Facility Switching Arrangement</i></p> <p>An arrangement to provide switching between two Voiceband Special Access Services. This arrangement may require a Voiceband control circuit to control the switching arrangement at an additional charge.</p>	
<p>8. <i>Automatic Protection Switch</i></p> <p>Consists of special switching equipment placed at both ends of a duplicate DS1 facility (i.e., DS1, High Capacity Circuit) for automatic switching to the duplicate (standby) facility in the event the active facility is inoperative.</p>	
<p>Duplicate facilities may terminate at a serving wire center, a CDL or both. The option provided under this tariff only includes the APS(s) located at a serving wire center(s). When the duplicate facility terminates at a CDL, the customer will be responsible for providing the associated APS and ensuring it is compatible with the Company provided switch if appropriate.</p>	
<p>The duplicate facilities are not a part of this supplemental feature.</p>	
<p>9. <i>Improved Termination Option</i></p> <p>Improved Termination provides for a fixed 600 ohm impedance, an increased range of transmission levels, and simplex reversal (when applicable) on an effective four-wire channel. This optional feature is available with most Voiceband services with a four-wire point of termination. Company equipment is required at the customer's premises where this option is ordered.</p>	
<p>The Improved Termination option will be ordered and rates and charges, as set forth in VI.G.5., will apply on a per SAL basis. Technical parameters and the applicable Voiceband services are specified in Section 7000 of the Industry Standard Technical Interface Reference Manual.</p>	

**VI. SPECIAL ACCESS** (Continued)

<p><b>10. Improved Equal Level Echo Path Loss Option – ELEPL-2</b></p> <p>This option provides improved echo control parameters for an effective two-wire channel at a four-wire point of termination. Placement of Company equipment may be required at the customer's premises with the two-wire point of termination.</p>	
<p>The term "Equal Level Echo Path Loss" (ELEPL) represents the measure of Echo Path Loss (EPL) at a four-wire interface which is corrected by the difference between the send and receive Transmission Level Point (TLP), i.e., <math>ELEPL = EPL - TLP (send) + TLP (receive)</math>.</p>	
<p>Improved ELEPL rates and charges will apply on a per SAL basis at the rates set forth in VI.G.5.b.. Technical parameters are specified in Section 7000 of the Industry Standard Technical Interface Reference Manual.</p>	
<p><b>E. <u>Description of Multiplexing Arrangements</u></b></p> <p>Multiplexing Arrangements provide the function to convert a single higher capacity or bandwidth circuit for bulk transport to several lower capacity or bandwidth circuits. Cascading multiplexing occurs when a high capacity analog or digital channel is de-multiplexed to provide channels with a lesser capacity and one of the lesser capacity channels is further de-multiplexed. For example, a DS1C may be de-multiplexed to two (2) DS1 facilities and then the DS1 facilities may be further de-multiplexed to twenty-four (24) Voiceband channels.</p>	
<p>When cascading multiplexing is performed in the same or different Hub Wire Center, a charge for the additional multiplexing unit will also apply. When cascading multiplexing is performed at a different Hub Wire Center, Special Transport will also apply between the involved Hub Wire Centers.</p>	
<p>Listed below are the multiplexing arrangements offered under this tariff.</p> <p><b>1. <i>Voice to Narrowband</i></b></p> <p>An arrangement that multiplexes sixteen (16) 0 to 75 baud narrowband circuits to a single voice grade circuit, or a single voice grade circuit to sixteen 0 to 75 baud narrowband circuits. This arrangement is an obsolete offering and is limited to those circuits so equipped and in service as of October 25, 1991.</p>	
<p><b>2. <i>Group to Voice</i></b></p> <p>An arrangement that multiplexes twelve (12) voice grade circuits to a single wideband analog group band circuit, or multiplexes a single wideband analog group band circuit to twelve (12) voice grade circuits.</p>	
<p><b>3. <i>Supergroup to Group</i></b></p> <p>An arrangement that multiplexes five (5) wideband analog group band circuits to a single wideband analog supergroup band circuit, or multiplexes a single wideband analog supergroup band circuit to five (5) wideband analog group band circuits.</p>	

**VI. SPECIAL ACCESS** (Continued)

<p>4. <i>Mastergroup to Supergroup</i></p> <p>An arrangement that multiplexes ten (10) wideband analog supergroup band circuits to a single wideband analog mastergroup band circuit, or multiplexes a single wideband analog mastergroup band circuit to ten (10) wideband analog supergroup band circuits.</p>	
<p>5. <i>DS1 to Voice</i></p> <p>An arrangement that multiplexes twenty-four (24) voice grade circuits to a single DS1 digital circuit at a rate of 1.544 Mbps, or multiplexes a single DS1 digital circuit at a rate of 1.544 Mbps to twenty-four (24) voice grade circuits. If this DS1 terminates in a DDS hub, a channel(s) of the DS1 can be used to provide DDS; however, DDS service stops at the DS1 interface. Multiple channels may be required to provide individual Program Audio Channels.</p>	
<p>Up to sixteen (16) channels of this DS1 can be used for Direct Digital Service (DDS-like service) with the assurance that circuit performance parameters will be met. If more than sixteen (16) channels are used for DDS-like service, the performance parameters for the DS1 and all circuits riding the DS1 will not be guaranteed.</p>	
<p>FT1 can be used in conjunction with DS1 to Voice Multiplexing in groupings of N x 56 Kbps or N x 64 Kbps where N = 2, 4 or 6, to a single DS1 digital circuit at a rate of 1.544 Mbps.</p>	
<p>6. <i>DS1C to Voice</i></p> <p>An arrangement that multiplexes forty-eight (48) voice grade circuits to a single DS1C digital circuit at a rate of 3.152 Mbps, or multiplexes a single DS1C digital circuit at a rate of 3.152 Mbps to forty-eight (48) voice grade circuits.</p>	
<p>7. <i>DS1C to DS1</i></p> <p>An arrangement that multiplexes two (2) DS1 digital circuits to a single DS1C digital circuit at a rate of 3.152 Mbps, or multiplexes a single DS1C digital circuit at a rate of 3.152 Mbps to two (2) DS1 digital circuits.</p>	
<p>8. <i>DS3 to DS1</i></p> <p>An arrangement that multiplexes twenty-eight (28) DS1 digital circuits to a single DS3 digital circuit at a rate of 44.736 Mbps, or multiplexes a single DS3 digital circuit at a rate of 44.736 Mbps to twenty-eight (28) DS1 digital circuits.</p>	
<p>9. <i>DS3C to DS1</i></p> <p>An arrangement that multiplexes fifty-six (56) DS1 digital circuits to a single DS3C digital circuit at a rate of 89.472 Mbps, or multiplexes a single DS3C digital circuit at a rate of 89.472 Mbps to fifty-six (56) DS1 digital circuits.</p>	

## VI. SPECIAL ACCESS (Continued)

<p><b>10. Group to DS1</b></p> <p>An arrangement that multiplexes two (2) wideband analog groupband circuits to a single DS1 digital circuit at a rate of 1.544 Mbps, or multiplexes a single DS1 digital circuit at a rate of 1.544 Mbps to two (2) wideband analog groupband circuits.</p>	
<p><b>11. Digital Data Carrier Multiplexer</b></p> <p>An arrangement that multiplexes twenty-three (23) 64 kbps digital circuits for connection to either subrate data multiplexers as described in VI.E.13. following or 56 kbps office channel units as described in VI.E.13. following, to a single DS1 1.544 Mbps digital circuit. This arrangement consists of a charge for the basic multiplexer and a charge for each 64 kbps digital circuit equipped and connected.</p>	
<p><b>12. Digital Data Subrate Multiplexer</b></p> <p>Used with cascading multiplexing, the Digital Data Subrate Multiplexer is an arrangement that multiplexes the following quantities of subrate digital data circuits into a single 64 kbps digital circuit: 1.) twenty (20) 2.4 kbps, 2.) ten (10) 4.8 kbps or 3.) five (5) 9.6 kbps. In turn, the 64 kbps digital circuit is then multiplexed to a single DS1 digital circuit using the Digital Data Carrier Multiplexer described in VI.E.12..</p>	
<p><b>F. <u>Rate Regulations</u></b></p> <p>This section contains specific regulations governing the rates and charges that apply for Special Access Service.</p> <p><b>1. <i>Types of Rates and Charges</i></b></p> <p>There are four (4) types of rates and charges. These are monthly rates, daily rates, hourly rates and nonrecurring charges. The rates and charges are described as follows:</p> <p>a. <b>Monthly Rates</b></p> <p>Monthly rates are recurring charges that apply each month or fraction thereof that a Special Access Service is provided. For billing purposes, each month is considered to have thirty (30) days.</p>	
<p>b. <b>Daily Rates</b></p> <p>Daily rates are recurring charges that apply to each twenty-four (24) hour period or fraction thereof that a part-time Program Audio Special Access Service is provided. This twenty-four (24) hour period is not limited to a calendar day. When part-time Program Audio service is provided for ten (10) or more consecutive days it will be treated as a full-time service and monthly rates will apply. In no event will the charges for continuous part-time Program Audio service exceed the amount that would be charged in the same time period for full-time service.</p>	

**VI. SPECIAL ACCESS** (Continued)

<p>c. Hourly Rates</p> <p>Hourly rates are recurring charges that apply to each sixty (60) minute period, or fraction thereof, that a part-time Videoband Special Access Service is provided. This billing period commences when the video circuit is available for the customer's use and ceases when the customer's use is discontinued. There is a maximum monthly charge that may be assessed to any Temporary Videoband Special Access Service. The maximum charge during any thirty (30) day period will be that amount equal to one hundred (100) hours of use.</p>	
<p>d. Nonrecurring Charges</p> <p>Nonrecurring charges are one-time charges that apply for specific work activity, (i.e., installation of service or change to an existing service). The types of nonrecurring charges that apply for Special Access Service are those listed below.</p> <p>(1) Special Access Ordering Charges</p> <p>Special Access Ordering Charges are associated with the work performed by the Company in connection with the receiving, recording and processing of customer service requests. There are two (2) types of service ordering charges.</p> <p>(a) Initial Ordering Charge – Special Access</p> <p>This charge applies on a per Access Service Request (ASR) basis, including those requests to add additional terminations to an existing service.</p>	
<p>(b) Subsequent Ordering Charge – Special Access</p> <p>This charge applies on a per ASR basis for modifications to an existing service. This would include activities such as:</p> <p>(i) Additions of supplemental features and multiplexing arrangements.</p>	
<p>(ii) Changes in the type of transport rate option from Switched Transport to Special Transport for FGA and FGB Switched Access Service as described in Section V..</p>	
<p>(2) Service Installation Charge</p> <p>The Service Installation Charge is associated with the work performed by the Company in connection with the physical installation activities involving central office and/or outside plant facilities. This charge applies on a per SAL basis for the installation of service, and for additional terminations to existing service.</p>	
<p>This charge does not apply to installations involving DS1 SAL or to Temporary Videoband Services. The installation charge for these services are set forth in VI.F.1.d.(5) and (6). In addition, this charge will not apply to part-time Program Audio SALs which are left in place and reused.</p>	

**VI. SPECIAL ACCESS** (Continued)

<p>(3) Design Change Charge</p> <p>The customer may request a design change to the service ordered. A design change is any change to a pending ASR for Special Access Service which requires engineering review. Design changes include such things as the addition or deletion of supplemental features or changes in the terminating options. Design changes do not include a change of IC CDL, or end user premises when its serving wire center changes or Special Access type (e.g., 2-wire to 4-wire Voiceband or Voiceband to Program Audio, etc.). Changes of this nature will require the issuance of a new ASR and the cancellation of the original ASR. The cancellation charges apply as set forth in <i>IV.B.6.</i></p>	
<p>The Company will review the requested change, notify the customer whether the change can be accommodated and specify if a new service date is required. If the customer authorizes the Company to proceed with the design change, a Design Change Charge will apply.</p>	
<p>The Design Change Charge, as set forth in <i>VI.G.1.</i>, will apply on a per ASR per occurrence basis, for each ASR requiring a design change.</p>	
<p>If a change of service date is required, the Service Date Change Charge as set forth in Section <i>IV.</i> will also apply.</p>	
<p>(4) Installation of Supplemental Features and Multiplexing Arrangements</p> <p>Nonrecurring charges apply for the installation of supplemental features and multiplexing arrangements available with Special Access service. The charge applies whether the feature or multiplexing arrangement is installed coincident with the initial installation of service or at any time subsequent to the installation of service. These charges are in addition to the appropriate Special Access Ordering Charge as set forth in <i>VI.F.1.d.(1)</i>.</p>	
<p>(5) Installation of DS1, Fiber Connect, FT1 DDS and DS3 Special Access Lines</p> <p>(a) DS1 Standard Arrangement</p> <p>There are two (2) levels of NRC and monthly charges for the installation of a DS1 SAL as described in <i>VI.G.10.a.</i> The "First System" charge is assessed per SAL for the first DS1 service ordered by a customer between CDLs or a Hub Wire Center. When the same customer requests additional DS1 service on the same ASR, to be installed at the same time and between the same CDLs as the "First System" DS1 SAL, the lesser charge under "Additional System" will apply. In addition to these charges, the appropriate Special Access Ordering Charge as described in <i>VI.F.1.d.(1)</i> will apply. The charge is found in <i>VI.G.1.</i></p>	
<p>(b) Fiber Connect Service Optional Payment Plan (OPP) Arrangement</p> <p>Customers subscribing to the Fiber Connect OPP arrangements, at rates in <i>VI.G.12.</i>, will be assessed a nonrecurring charge. The NRC represents the termination of four (4) DS1 equivalent SALs on a single fiber optic transmission system. The customer must order four (4) DS1s and indicate on the ASR the Network Channel Interface (NCI) code for either electrical or fiber optic termination.</p>	

**VI. SPECIAL ACCESS** (Continued)

<p>The NRC for installation of a Fiber Connect OPP SAL in <i>VI.G.12.</i> will apply to existing Fiber Connect OPP customers when required for changes and other service rearrangements as described in <i>VI.F.1.d.(7)</i>.</p>	
<p>(c) Fractional T1 Standard Arrangement</p> <p>Customers subscribing to Fractional T1 service, at rates in <i>VI.G.13.a.</i>, will be assessed a nonrecurring charge. The NRC for Fractional T1 service will be assessed per SAL.</p>	
<p>(d) Fractional T1 Optional Payment Plan (OPP) Arrangements</p> <p>Customer subscribing to the Fractional T1 OPP arrangements, at rates in <i>VI.G.13.b.</i>, will not be assessed a nonrecurring charge.</p>	
<p>The regulations in Section <i>VI.F.1.d.(7)</i> will apply to existing FT1 OPP customers when required for changes and other service rearrangements.</p>	
<p>(e) DDS Standard Arrangements</p> <p>Customers subscribing to DDS month to month service, at rates in <i>VI.G.20.a.</i>, will be assessed a Service Installation Charge, per SAL, as described in <i>VI.F.1.d.(2)</i>. The charge is found in <i>VI.G.1.</i>.</p>	
<p>(f) DDS Optional Payment Plan (OPP) Arrangements</p> <p>Customers subscribing to the DDS OPP arrangements, at rates in <i>VI.G.20.c.</i>, will not be assessed a nonrecurring charge.</p>	
<p>The regulations in Section <i>VI.F.1.d.(7)</i> will apply to existing DDS OPP customers when required for changes and other service rearrangements.</p>	
<p>(g) DS3 Arrangements</p> <p>There are two (2) levels of charges for the installation of DS3 SALs as found in <i>VI.G.14.</i>. The First Special Access Line charge is assessed for the first DS3 SAL ordered by the customer. When the same customer requests additional DS3 SALs, to be installed between the same locations, the Additional Special Access Line charge will apply for each SAL ordered (maximum of two (2) Additional SALs in a 3 System DS3).</p>	
<p>For Individual DS3s, the charge for installation will apply at the same rate per DS3 SAL.</p>	
<p>(6) Installation of Temporary Videoband Service</p> <p>Installation charges will be developed on an individual case basis (ICB).</p>	
<p>No other nonrecurring charges [i.e., those described in <i>VI.F.1.d.(1)</i> and (2)] will be assessed to the installation of Temporary Videoband Service.</p>	



**VI. SPECIAL ACCESS** (Continued)

<p>(7) Service Rearrangements</p> <p>Service rearrangements are changes to existing (installed) services which may be administrative only in nature, or involve an actual physical change to the service. Changes to pending orders are set forth in <i>IV.B.2.</i></p>	
<p>Changes in the type of service will be treated as a discontinuance of the service and an installation of a new service.</p>	
<p>Changes in the physical location of the point of termination are treated as moves which are described and charged for as in <i>VI.F.4.</i></p>	
<p>Administrative changes will be made without charge(s) to the customer.</p>	
<p>Administrative changes are as follows:</p> <ul style="list-style-type: none"> <li>- Change in name or ownership or transfer of responsibility from one customer to another, provided there is no interruption of use or relocation of Special Access service.</li> <li>- Change of customer or customer's end user premises address when the change of address is not a result of a physical relocation of equipment,</li> <li>- Change in billing data (name, address, or contact name or telephone number),</li> <li>- Change of customer circuit identification,</li> <li>- Change of billing account number,</li> <li>- Change of customer test line number,</li> <li>- Change of customer or customer's end user contact name or telephone number,</li> <li>- Change of agency authorization, and</li> <li>- Change in jurisdiction involving no physical changes to the service.</li> </ul>	
<p>All other service rearrangements will be charged for as follows:</p> <ul style="list-style-type: none"> <li>- If the change involves the addition of another termination to an existing multipoint service, the Initial Ordering Charge - Special Access will apply plus the Service Installation charge for each location added.</li> </ul>	
<ul style="list-style-type: none"> <li>- If the change involves the addition of supplemental feature or multiplexing arrangement, the Subsequent Ordering Charge - Special Access will apply plus the installation charge associated with the supplemental feature or arrangement.</li> </ul>	
<ul style="list-style-type: none"> <li>- If the change involves the addition of another termination to an existing multipoint service, the Initial Ordering Charge - Special Access will apply plus the Service Installation charge for each location added.</li> </ul>	
<ul style="list-style-type: none"> <li>- If the change involves the addition of supplemental feature or multiplexing arrangement, the Subsequent Ordering Charge - Special Access will apply plus the installation charge associated with the supplemental feature or arrangement.</li> </ul>	

**VI. SPECIAL ACCESS** (Continued)

<ul style="list-style-type: none"> <li>- If the change involves only changing the type of network interface, with no change in facility, the Subsequent Ordering Charge - Special Access will apply per ASR for each customer designated location requiring a network interface change. In addition, an amount equal to one half (1/2) of the Installation charge for each service requiring a network interface change.</li> </ul>	
<ul style="list-style-type: none"> <li>- If the change involves changing a two-wire service to a four-wire service or vice versa, the Subsequent Ordering Charge - Special Access will apply plus the Service Installation charge for each location changed.</li> </ul>	
<ul style="list-style-type: none"> <li>- In cases change involves only the retermination of an existing circuit within the same wire center with no change in the facilities involved, in association with the installation of high capacity facilities and/or multiplexing arrangements (i.e., a rollover), the Subsequent Ordering Charge - Special Access will apply per ASR plus an amount equal to one half (1/2) the Service Installation charge.</li> </ul>	
<ul style="list-style-type: none"> <li>- If the change involves the retermination of an existing circuit within a wire center and a change in the facilities involved (i.e., rollover reroute), in association with the installation or use of high capacity facilities and/or multiplexing arrangements, the Subsequent Ordering Charge - Special Access will apply plus the appropriate Service Installation charge for the location involved.</li> </ul>	
<ul style="list-style-type: none"> <li>- In cases where multiple service rearrangements or an additional termination or a move and a service rearrangement are requested on a single ASR, the total charge will never exceed the full nonrecurring charge for the basic service.</li> </ul>	
<p><b>2. Minimum Periods</b></p> <p>Special Access is provided for a specified minimum period. Minimum periods and minimum period charges are described in Section IV..</p>	
<p><b>3. Mileage Measurement</b></p> <p>The mileage to be used to determine the monthly rate for the Special Transport is calculated on the airline distance between the serving wire centers involved (i.e., CDL serving wire center or Hub Wire Center or WATS Serving Office). Where the calculated miles include a fraction, the value is always rounded up to the next full mile. Where the calculated value is zero (0), no Special Transport mileage is charged.</p>	
<p>When there is a Hub Wire Center involved, the Special Transport mileage will be measured from the Hub Wire Center to the serving wire centers of each of the CDLs connected to the hubbed facilities. Mileage is computed for each section and rates are applied accordingly. However, when a Special Access facility is routed through a Hub Wire Center for purposes other than customer specified such as bridging or multiplexing (e.g. the Company chooses to so route for test access purposes), rates will be applied only to the distance calculated between the wire centers serving the CDLs.</p>	
<p>The rates for the mileage are applied per airline mile using the V&amp;H coordinates method.</p>	

**VI. SPECIAL ACCESS** (Continued)

<p>4. <i>Moves</i></p> <p>A move involves a change in the physical location of the point of termination of Special Access. A move normally involves an interruption of Special Access for the period required to complete the move. No credit allowance will be granted for that period. Special Construction as set forth in Section XI. may also be applicable at the different CDL. The charge for the move depends on whether the move is within the same CDL or to a different CDL.</p>	
<p>A customer may request that Special Access not be interrupted during a move. To comply with that request, it may be necessary to install a duplicate Special Access, and subsequently discontinue the existing Special Access. Charges, monthly and nonrecurring, will apply for the duplicate Special Access. A new minimum period will be established for the duplicate portion of the Special Access, depending on which end of the Special Access is moved. The customer will remain responsible for all minimum period charges associated with the corresponding portion of the disconnected Special Access.</p> <p>a. Same CDL</p> <p>When the move of a termination of FIA, as defined in Section III.A.5., for Special Access is to a new point within the same CDL (same address and/or same building), the charge for the move will be the Subsequent Ordering Charge - Special Access plus an amount equal to one half (1/2) the Service Installation charge for the service being reterminated. There will be no change in the minimum period requirements. For services subject to payment plan regulations, the same payment period will remain in force.</p>	
<p>b. Different CDL</p> <p>(1) When the move is to a different CDL (different address and different building), except as specified below, it will be treated as a disconnect and an installation of service. The Initial Ordering Charge - Special Access will apply plus the Service Installation charge for the service termination(s) affected. Termination Liability will not be assessed if service is maintained for the remainder of the existing payment plan. See Termination Liability, Section III.D.5..</p>	
<p>(2) When the move is to a different CDL but served by the same serving wire center, the following conditions apply:</p> <ul style="list-style-type: none"> <li>- A change ASR will be required.</li> <li>- Subsequent Ordering Charge - Special Access will apply plus the appropriate service installation charge for the service termination(s) affected.</li> <li>- For Special Access services subject to payment plan regulations, if the customer of record remains the same with no lapse in service, the Subsequent Ordering Charge - Special Access and appropriate NRCs apply. Otherwise, the move will be treated as a disconnect and an installation of service and all appropriate NRCs will be applicable. See III.D.5.d. for exceptions to Termination Liability.</li> </ul>	

**VI. SPECIAL ACCESS** (Continued)

<p>5. <i>Rates and Charges on an Individual Case Basis</i></p> <p>a. The monthly/hourly rates and nonrecurring charges for the following service offerings will be developed on an Individual Case Basis:</p> <ul style="list-style-type: none"> <li>- Full-time and Temporary (Part-time) Videoband Facilities</li> <li>- Wideband Analog - Group Band Facilities</li> <li>- Wideband Analog - Supergroup Band Facilities</li> <li>- Wideband Analog - Mastergroup Band Facilities</li> <li>- Wideband Data Facilities</li> <li>- High Capacity Digital DS1C (3.152 Mbps) Special Access Lines</li> <li>- High Capacity Digital DS3 Special Access Lines with optical interface</li> <li>- High Capacity Digital DS3 Special Access Lines Group System</li> <li>- High Capacity Digital DS3 Special Access Lines Unlimited System</li> <li>- High Capacity Digital DS3C (89.472 Mbps) Facilities</li> </ul>	
<p>b. The monthly rates and nonrecurring charges for the following Multiplexing Arrangements will be developed on an Individual Case Basis:</p> <p style="padding-left: 40px;">Group to Voice Supergroup to Group Mastergroup to Supergroup</p> <p style="padding-left: 40px;">DS3C to DS1 Group to DS1</p>	
<p>6. <i>Hub Wire Centers</i></p> <p>A Hub Wire Center is a Company designated serving wire center at which bridging or multiplexing arrangements are provided. Bridging is used to connect three (3) or more CDLs in a multipoint arrangement. The multiplexing arrangements channelize analog or digital facilities to individual services requiring a lower capacity or bandwidth.</p>	
<p>Although Hub Wire Centers are defined as serving wire centers at which bridging or multiplexing arrangements are performed, they are not limited to providing these functions and may provide any other types of Special Access services offered in this tariff. For example, the Company will designate certain Hub Wire Centers for Program Audio service offerings.</p>	
<p>The Company will designate the Hub Wire Center locations. Different locations may be designated as Hub Wire Centers for different functions, such as bridging or multiplexing arrangements, for different facility capacities (e.g., multiplexing from digital to digital may occur at one wire center while multiplexing from digital to analog may occur at a different wire center).</p>	
<p>Some of the types of multiplexing provided include the following:</p> <ul style="list-style-type: none"> <li>- from higher to lower bit rate,</li> <li>- from higher to lower bandwidth,</li> <li>- from digital to voice grade service.</li> </ul>	

**VI. SPECIAL ACCESS** (Continued)

<p>The transmission performance for the end to end Special Access provided from CDLs will be that of the lower capacity or bit rate. For example, when a DS1 Special Access is multiplexed to voice frequency circuits, the transmission performance will be Voiceband, not High Capacity.</p>	
<p>The Company will commence billing the monthly rate for the Special Access Line and Special Transport or Special Access Cross Connect Charge for EIS arrangements, for the High Capacity facility to the Hub Wire Center as of the service date, even though individual services utilizing those facilities may not be installed until a later date. If the customer has designated the type of multiplexing to be provided with the High Capacity facility, the nonrecurring charge for the Multiplexing Arrangement will be billed to the same customer at that same time, and the billing for the monthly rate will begin.</p>	
<p>Individual Special Access rates (by Special Access type) will apply for the Special Access Line and additional Special Transport facilities (if required) for each channelized Special Access. These will be billed to the customer specified on the ASR as each individual Special Access is installed. The appropriate application of rate elements is specified in VI.F.7.b.. Shared use of a digital high capacity facility is provided for in VI.F.7.a..</p>	
<p>A customer may order full-time and/or part-time Program Audio Services between two (2) CDLs, or between a CDL and a Hub Wire Center, and will be billed accordingly at the rates set forth in Sections VI.G.6., VI.G.7., VI.G.8. and VI.G.9..</p>	
<p>At the request of the customer, the full-time and/or part-time services provided to a Hub Wire Center may be connected together in the following configurations: full-time to full-time, full-time to part-time, or part-time to part-time.</p>	
<p>The rates that apply for Program Audio Services between each CDL and the Hub Wire Center are Special Transport, if applicable, and Special Access Line. In addition, rates for Supplemental Features and Inside Wiring may be applicable.</p>	
<p><b>7. Shared Use Analog and Digital High Capacity Services</b></p> <p>Monthly charges for a DS1 or DS3 high capacity shared use facility will be apportioned between Switched and Special Access based on the relative proportion of channels used for switched and special access in the following manner.</p>	
<p>If the facility is ordered as Special Access, rating as Special Access will continue until such time as a portion of the available capacity is used to provide Switched Access service. As individual channels are activated for Switched Access, monthly charges will be apportioned between Switched and Special Access based on the number of channels used for Switched Access and the number of remaining channels on the Special Access facility according to the following formula:</p> <ul style="list-style-type: none"> <li>- The total shared use charge is equal to the Monthly Switched Access Charge times the number of channels used for Switched Access divided by twenty-four (24) for DS1 or six hundred seventy-two (672) for DS3 plus the monthly Special Access Charge times the number of channels remaining for Special Access divided by twenty-four (24) for DS1 or six hundred seventy-two (672) for DS3.</li> </ul>	

## VI. SPECIAL ACCESS (Continued)

<p>If the facility is ordered as Switched Access, rating as Switched Access will continue until such time as a portion of the available capacity is used to provide Special Access service. As individual channels are activated for Special Access, monthly charges will be apportioned between Switched and Special Access based on the number of channels used for Special Access and the number of remaining channels on the Switched Access Facility according to the following formula:</p> <ul style="list-style-type: none"> <li>- The total shared use charge is equal to the Monthly Special Access divided by twenty-four (24) for DS1 or six hundred seventy-two (672) for DS3 plus the monthly Switched Access Charge times the number of channels remaining for Switched Access divided by twenty-four (24) for DS1 or six hundred seventy-two (672) for DS3.</li> </ul>	
<p>The monthly Switched and Special Access rate used will be the appropriate rate (Special Access SAL, Special Transport, Multiplexer and/or Cross Connect Arrangement and Switched Transport - Facility, EOS, Information Surcharge, Switched Transport - Termination, Multiplexer and/or Cross Connect Arrangement) for the underlying shared use facility, i.e., if the underlying facility is a Special Access DS3 service, the corresponding Switched Access DS3 Transport will be used to determine the Switched Access monthly charges.</p>	
<p>Shared use of Special Access Fractional T1 (FT1) and Fiber Connect Services when feasible, will be addressed on a case by case basis.</p>	
<p>Where shared use of a DS3 Cross Connect arrangement for EIS is desired, it must be ordered as a Switched Access DS3 Cross Connect Service.</p>	
<p><b>8. Temporary Videoband Service</b></p> <p>The rates and charges for use of facilities for Temporary Videoband Service are assessed on a per hop basis. A hop is defined as the transporting of a one-way video and associated audio signal(s) in a direct path from a transmitter location to the adjacent receiver location. The distance of a single hop is primarily a factor of the local geographics of the video path, therefore, more than one hop may be required between CDLs. The following diagram depicts a single hop.</p> <div style="text-align: center; margin: 10px 0;"> <pre> graph LR     T[T] --- Path[~~~~] --- R[R]             </pre> </div>	
<p>There is one separate rate category for a hop which is based on the provisioning of service:</p> <ul style="list-style-type: none"> <li>- Video broadcasts which use nonpermanent facilities.</li> <li>a. Use of Nonpermanent Facilities for Temporary Videoband Service</li> </ul> <p style="padding-left: 40px;">Temporary Videoband Service is provided by nonpermanent facilities.</p>	
<p>Nonpermanent facilities consist of portable microwave equipment (e.g., transmitter, receiver, antenna, connecting cables and associated equipment), which is set up for the broadcast and subsequently removed after the broadcast.</p>	

**VI. SPECIAL ACCESS** (Continued)

<p>The rates and charges for Temporary Videoband Service provided over nonpermanent facilities are developed on an individual case basis.</p>	
<p>b. Joint Provisioning of Service</p> <p>Where more than one company is involved in the provisioning of a Temporary Videoband Service, such jointly provided facilities are subject to the rules and regulations outlined in Section <i>III.G.</i> and <i>IV.C.</i> (Single Company and Multiple Company Billing). When the Multiple bill option is employed as set forth in <i>III.G.1.b.(2)</i>, the rates will apply as follows: When nonpermanent facilities are used to provision the service and the service is jointly provided, the rates for the Video nonbroadcast will be one-half (1/2) the nonrecurring charge and one-half (1/2) the hourly charge for the facilities used to provide the service.</p>	
<p>When a single bill option is employed as set forth in Section <i>III.G.1.b.(1)</i> the rates for the Video nonbroadcast, are the entire nonrecurring charge and the entire hourly charge for the facilities used to provide the service.</p>	
<p>The entire Technician standby charge will be applied to the time the service is provided under either a Single bill option or a Multiple bill option.</p>	
<p><b>9. High Capacity Digital DS1 and DS3 Optional Arrangements-Riders</b></p> <p>a. DS1 Optional Arrangement-Rider<sup>8</sup></p> <p>A DS1 may also be utilized to traverse a customer's Intrastate Optical Networking facility, for SONET services, between CDLs. The customer will be charged a monthly recurring charge that includes add/drop multiplexing and is applicable per rider circuit. The rate in <i>VI.G.10.c.</i> is in addition to the Optical Networking rates in the Company's FCC tariff.</p>	
<p>b. DS3 Optional Arrangement-Rider<sup>7</sup></p> <p>A DS3 may also be utilized to traverse a customer's Intrastate Optical Networking facility, for SONET services, between CDLs. The customer will be charged a monthly recurring charge that includes add/drop multiplexing and is applicable per rider circuit. The rate in <i>VI.G.17.</i> is in addition to the Optical Networking rates in the Company's FCC tariff.</p>	

---

<sup>8</sup> Due to technical limitations, the DS1 and DS3 riders cannot be utilized on an OC192 facility, nor offered on OC3c, OC12c, or OC48c CDL Links.

**VI. SPECIAL ACCESS** (Continued)

<p><i>10. High Voltage Protection</i></p> <p>a. Description</p> <p>High Voltage Protection Service is used at customer locations that may require special equipment to isolate or neutralize Ground Potential Rise (GPR) and/or induced voltage caused by faults in the electric power system. GPR is a voltage difference between two (2) or more ground electrodes caused by earth return currents. GPR on cable facilities can occur, for example, when current from lightning surges flow to ground, but GPR often is associated with voltage generated as the power system fault currents flow to ground. Maximum GPR is developed by the percentage of line-to-ground fault current entering earth through electrode impedance.</p>	
<p>This feature will provide high voltage isolation for Special Access telecommunications, while enabling the normal transmission between the Company wire center and the equipment at the customer's location during GPR environment due to electrical power faults.</p>	
<p>b. Provisioning</p> <p>The Company shall determine the proper levels of protection required on its network to isolate or neutralize electrical hazard, based on the information provided by the customer. The customer shall provide the Company, in writing, the technical data necessary for the Company to determine the high voltage protection requirements, at the time of application for the initial service, additions to, or changes in the existing service. In addition, the customer shall notify the Company before making changes in the electric supply that will increase the GPR at the location.</p>	
<p>The technical data for the customer's location shall include, but not be limited to, the following:</p> <ul style="list-style-type: none"> <li>- ground grid area in square feet</li> <li>- ground grid impedance in ohms</li> <li>- X/R ratio at worst case fault location</li> <li>- GPR in volts MS</li> </ul>	
<p>Based on the customer's technical data provided to the Company, the Company will provide the necessary high voltage protection equipment at the Company's demarcation point on the customer's premises and at the remote drainage location. The placement of the equipment by the Company shall in no way release the customer of its responsibility for damage, loss or claims caused by electrical hazards resulting from the customer's electric power system. The Company's liability for damage, loss or claims is set forth under <i>III.A.3.</i></p>	
<p>The customer may elect to furnish the equipment at its premises to isolate or neutralize the electrical hazard subject to the approval of the Company; however, such approval by the Company shall not relieve the customer of its responsibility to install or maintain adequate high voltage equipment. The high voltage protection equipment at the customer's location will be exclusively owned either by the Company or by the customer.</p>	
<p>When the customer provides the high voltage equipment at its premise, the Company will provide the necessary high voltage equipment at the wire center and remote drainage location. The Company will be responsible up to and including the network interface for the termination of Special Access Services regardless of ownership of the high voltage protection equipment.</p>	



**VI. SPECIAL ACCESS** (Continued)

<p>The Company will inspect and verify adequacy of the high voltage protection equipment when service is established and at such future times as deemed necessary due to additions, deletions, rearrangements, routine maintenance or for the purpose of verifying the adequacy of the high voltage protection equipment.</p>	
<p>c. Claims and Demands for Damage</p> <p>In addition to the provisions in Section <i>III.C.11.</i>, the customer shall defend, indemnify and save harmless the Company from any and all loss, claims, demands, suits or other action or any liability whatsoever, whether suffered, made, instituted or asserted by the customer or by any other party or person, for any personal injury to or death of any person or persons, or for any loss, damage or destruction of any property whether owned by the customer or others, caused or claimed to have been caused directly or indirectly by the installation, operation, failure to operate, maintenance, removal, presence, condition, location or use of such equipment and services associated with high voltage protection equipment furnished by the Company or with customer equipment when combined or connected with facilities of the Company.</p>	
<p>Services provided by the Company shall not cause the Company to become responsible for damage, loss or claims caused by electrical hazard resulting from a customer's electric power system.</p>	
<p>d. Network Outage</p> <p>Interruptions or outages of services provided to customers may occur for reasons, such as facility damage due to storm loading, vehicle accident, lightning strike, or other acts of God. Circuit failures caused by such events cannot be prevented by services provided in accordance with this service. However, interruptions and service outages due to fault-produced ground potential rise and induction can and should be minimized. The Company expressly states that provision of the high voltage equipment cannot prevent such service outages as may normally occur due to the preceding circumstances. It is the responsibility of the customer to provide sufficient protection to prevent damage caused by such events.</p>	
<p>Interruptions or outages due to the effects of GPR and/or induction of faults in the customer's power generating, transmission and/or distribution system are minimized through the installation and maintenance of high voltage protection equipment which is designed to operate in a fault-produced electrical environment.</p>	
<p>e. Compliance Statement</p> <p>The Company reserves the right to disconnect service one hundred twenty (120) days after giving the required notice, as set forth under Section <i>III.A.8.a.</i>, due to the following conditions:</p> <p>(1) The customer-provided equipment is nonfunctional or inadequate.</p>	
<p>(2) The customer fails, upon written notice, to establish or reestablish the required high voltage protection equipment or apply for and obtain such protection from the Company.</p>	
<p>(3) The customer fails to keep the Company informed of changed high voltage requirements.</p>	

**VI. SPECIAL ACCESS** (Continued)

<p>f. Rate Regulations</p> <p>(1) Minimum Period</p> <p>The minimum period for High Voltage Protection is one (1) month.</p>	
<p>(2) Rate Elements</p> <p>(a) Initial Common Equipment</p> <p>A nonrecurring charge and a monthly rate apply for the Initial Common (basic) Equipment used or the physical connection to the network interface. The Initial Common Equipment can accommodate up to eight Special Access facility terminations at a customer's location.</p>	
<p>(b) Terminating Equipment</p> <p>High Voltage Terminating Equipment is required for each Special Access facility termination. A nonrecurring charge and a monthly rate for the High Voltage Terminating Equipment apply in addition to the rates and charges for the Special Access facility as well as the associated Special Access Service regulations.</p>	
<p><b>11. DS3 High Capacity Service</b></p> <p>a. DS3 Rate Structure</p> <p>Option 1: 3 System DS3</p> <p>3 System DS3 SALs are provided as a system offering. The interface provided is electrical. Additional SALs may only be added with the same interface as the First System. All DS3 SALs are non-distance sensitive.</p>	
<p>Under a 3 System DS3, additional DS3 SALs, up to a maximum of two (2), may be ordered by the same customer, between the same CDL and serving wire center.</p>	
<p>Option 2: Individual DS3</p> <p>This option provides individual DS3 service. Before confirming the ASR for this option, the Company will verify the availability of a DS3 interface at the CDL. If a DS3 interface can be made available with no physical change to the existing configuration at the CDL, the ASR will be confirmed and processed. If this condition is not met, the customer will be advised and no charge will be assessed for the unprocessed ASR. The customer may then cancel the ASR or submit a new ASR for one of the services available under Option 1.</p>	
<p>SAL rates for Individual DS3s vary dependent on whether the interface provided is electrical or optical.</p>	

**VI. SPECIAL ACCESS** (Continued)

<p>Option 1, 3 System DS3s and Option 2, Individual DS3s may be ordered as protected SALs with an electrical interface. A protected DS3 SAL provides a spare transmission path (transmit and receive) connected to an automatic protection switch. In the event of failure in the primary service, traffic will be automatically transferred to the spare transmission facilities. The spare transmission path will normally be provided on the same route as the primary path. When a customer orders a protected DS3 SAL, the customer may request that the spare transmission path be provided via an alternate route provisioned as the Company may elect. If common points for the primary and alternate route become necessary, these points will be identified by the Company and provided to the ordering customer. Should the routing arrangement require special routing requirements specified by the customer, other rates and regulations as described in Section X. or Section XI. may be applicable.</p>	
<p>A customer may order the same or different type of DS3 SALs for each CDL(s) at which DS3 service is terminated.</p>	
<p>When a customer requests the disconnect of a DS3 service in the 3 System DS3, an Additional System DS3 SAL must be disconnected first. When only the First DS3 service exists, that service will be disconnected.</p>	
<p>Any costs associated with Special Construction as specified in Section XI. will apply.</p>	
<p>DS3 Special Transport contains two rate elements, Special Transport Termination and Special Transport Facility. Special Transport Termination rates apply for the termination of each end of the interoffice facility. Special Transport Facility rates apply for each airline mile of the interoffice facility.</p>	
<p>b. Minimum Service Period</p> <p>Individual DS3s and System DS3s are offered under four (4) minimum service periods, each with different rate levels. The minimum service periods are one (1), three (3), five (5) and seven (7) years. The customer must specify the minimum service period at the time the service is ordered. First and Additional DS3 SALs (3 System DS3s) can have a different minimum service period. However, each DS3 SAL of a two-point DS3 service must have the same minimum service period.</p>	
<p>The customer may select a longer minimum service period at any time, without penalty or application of nonrecurring charges, to obtain the lower monthly recurring rates associated with a longer minimum service period. When the customer selects this option, they will receive full credit for the amount of time they were under the shorter minimum service period. For example, if a customer ordered a one (1) year minimum service period, then decided after six (6) months to change to a three (3) year minimum service period, he will have a remaining obligation of thirty (30) months. The new recurring charges will apply subsequent to the effective date of the new minimum service period.</p>	
<p>c. Expiration of Minimum Service Period</p> <p>See Renewal Options, III.D.5.c., under Termination Liability.</p>	

**VI. SPECIAL ACCESS** (Continued)

<p>d. Discontinuance Without Liability – DS3 Minimum Service Period</p> <p>Should the recurring charges for a customer's DS3 service increase from the original recurring charges during the minimum service period, the customer may, at their option, terminate the DS3 service without penalty or liability.</p>	
<p>e. Discontinuance With Liability – DS3 Minimum Service Period</p> <p>See Termination Liability, Section III.D.5..</p>	
<p>f. Notification of Discontinuance</p> <p>Notice of discontinuance must be given by the customer at least thirty (30) days prior to actual discontinuance. Monthly charges will apply for a period of thirty (30) days from the date the Company receives discontinuance notification or until the requested discontinuance date, whichever period is longer.</p>	
<p>g. DS3 Multiplexer Cross Connect Arrangement</p> <p>For DS3 multiplexed services, the DS3 Multiplexer Cross Connect arrangement allows a customer to cross connect digital DS1 channels from one multiplexer to another multiplexer. The rate as specified in VI.G.19. will apply per cross connect arrangement. If the DS3 multiplexed services are located in different hub wire centers, DS1 special transport will apply in addition to the DS1 cross connect charge. The customer must provide the channel assignments (CFA and SCFA) for both multiplexed services on the ASR.</p>	
<p><b>12. Optional Payment Plan (OPP) for FT1, Fiber Connect and DDS</b></p>	
<p>a. General</p> <p>(1) The Terms and conditions specified herein are applicable to FT1, Fiber Connect and DDS services. Additional terms and conditions for DDS are found in VI.F.12.a..</p>	
<p>(2) Only the Special Access Line (SAL) rate element is available under an OPP. All other associated rate elements or additional features are available at the standard month-to-month tariffed rates and regulations.</p>	
<p>(3) FT1 OPP SAL rates will not be greater than standard month-to-month SAL rates. Fiber Connect is not available on a month-to-month basis.</p>	
<p>(4) Three (3) year and five (5) year OPP rates will be equal to or less than the one (1) year OPP rates. Decreases to the one (1) year OPP will flow through to the three (3) year and five (5) year OPP.</p>	
<p>(5) Payment periods of one (1) year, three (3) year, and five (5) year are available to all customers at the applicable rates in VI.G.12., VI.G.13.b. or VI.G.20.c. regardless of when they subscribe to an OPP arrangement.</p>	

## VI. SPECIAL ACCESS (Continued)

<p>b. Changes in Length of OPP Period</p> <p>Prior to the completion of the selected OPP period, the customer may elect to convert to a new OPP period of the same or different length, subject to the following conditions:</p> <ul style="list-style-type: none"><li>- No credit toward the new payment period will be given for payments made under the original OPP arrangement.</li><li>- Nonrecurring charges will not be reapplied for existing service(s).</li><li>- If the new OPP period is shorter in length than the time remaining under the existing OPP, the change to the new OPP period constitutes a disconnect of the existing OPP service and termination liability charges as outlined in Section III.D.5. will apply.</li></ul>	
<p>c. Renewal Options</p> <p>See Renewal Options, III.D.5.c., under Termination Liability</p>	
<p>d. Notification of Discontinuance</p> <p>An ASR for discontinuance of an OPP arrangement must be received by the Company at least thirty (30) days prior to actual disconnect of service. Monthly charges will apply for a period of thirty (30) days from the date the Company receives disconnect notification or until the requested disconnect date, whichever period is longer.</p>	
<p>e. Upgrade to Higher Speed Service</p> <p>Customers may elect to upgrade service(s) to a higher speed during an OPP period, subject to the following conditions:</p> <ul style="list-style-type: none"><li>- The upgraded service will be subject to all appropriate nonrecurring charges.</li><li>- Termination liability charges will not apply as long as the upgraded service remains connected at the same point of termination(s) or meets the requirements described in VI.F.5.b.(2).</li><li>- See III.d.5.d. for exceptions to Termination Liability.</li></ul>	
<p>f. Termination Liability</p> <p>See Section III.D.5..</p>	
<p>g. OPP for DDS</p> <p>For conversion of existing month-to-month DDS to an OPP arrangement, the customer will be required to submit a change order ASR to convert to the OPP. No service or billing interruption will occur when a customer converts from month-to-month rates to OPP rates. If no other changes to the service are ordered, no charge will apply.</p>	

## VI. SPECIAL ACCESS (Continued)

<p>13. <i>Optional Payment (OPP) for DS1</i></p> <p>a. General</p> <ul style="list-style-type: none"><li>- The terms and conditions specified herein are applicable to DS1 services.</li><li>- Only the Special Access Line (SAL) rate element is available under an OPP. All other associated rate elements or additional features are available at the standard month-to-month tariffed rates and regulations.</li><li>- Nonrecurring charges are not applicable for DS1 services subscribed to under an Optional Payment Plan.</li><li>- DS1 OPP SAL rates will not be greater than standard first system month-to-month SAL rates.</li><li>- Three (3) year and five (5) year OPP rates will be equal to or less than the one (1) year OPP rates.</li><li>- Payment periods of one (1) year, three (3) year, and five (5) year are available to all customers at the applicable rates in <i>VI.G.10.b.</i> regardless of when they subscribe to an OPP arrangement.</li><li>- The customer must designate on the ASR the payment period for the OPP.</li></ul>	
<p>b. Conditions</p> <ul style="list-style-type: none"><li>- Under the DS1 OPP rate structure, there is no distinction between first and additional systems. The DS1 Standard Arrangement in <i>VI.G.10.a.</i> does not apply.</li><li>- Installation charges do not apply to initial or subsequent DS1 services ordered under an OPP.</li><li>- Under an OPP arrangement, the same customer can order DS1 service from its CDL to different terminating CDLs.</li><li>- The terms for first and additional systems do not need to be coterminous.</li></ul>	
<p>c. Moves</p> <p>See Section <i>III.D.5.d.</i>, under Termination Liability.</p>	
<p>d. Conversion from Month-to-Month to an OPP</p> <ul style="list-style-type: none"><li>- For conversion of existing standard month-to-month DS1 services(s) to an OPP arrangement, the customer will be required to submit a change order ASR to convert to the OPP. No service or billing interruptions will occur when a customer converts from standard month-to-month rates to an OPP. If no other changes to the service(s) are ordered, only the Subsequent Ordering Charge-Special Access (<i>VI.G.1.</i>) will apply.</li></ul>	

## VI. SPECIAL ACCESS (Continued)

<p>e. Changes in Length of an OPP Period</p> <p>Prior to the completion of the selected OPP period, the customer may elect to convert to a new OPP period of the same or different length, subject to the following conditions.</p> <ul style="list-style-type: none"><li>- No credit toward the new payment period will be given for payments made under the original OPP arrangement.</li><li>- If the new OPP period is shorter in length than the time remaining under the existing OPP, the change to the new OPP period constitutes a disconnect of the existing OPP service and termination liability charges as outlined in Section <i>III.D.5.</i> will apply.</li></ul>	
<p>f. Renewal Options</p> <p>See Renewal Options, <i>III.D.5.c.</i>, under Termination Liability.</p>	
<p>g. Notification of Discontinuance</p> <p>An ASR for discontinuance of an OPP arrangement must be received by the Company at least thirty (30) days prior to actual disconnect of service. Monthly charges will apply for a period of thirty (30) days from the date the Company receives disconnect notification or until the requested disconnect date, whichever period is longer.</p>	
<p>h. Upgrade to higher Speed Service</p> <p>Customers may elect to upgrade service(s) to a higher speed during an OPP period, subject to the conditions in Section <i>III.D.5.</i>, Termination Liability.</p>	
<p>i. Termination Liability</p> <p>When OPP service is discontinued prior to the end of the period, termination liability charges as set forth in Section <i>III.D.5.</i> will apply.</p>	

**VI. SPECIAL ACCESS** (Continued)

<b>G. <u>Rates and Charges</u></b>		
1. <i>Special Access Ordering Charges</i>		
		<u>Nonrecurring Charge</u>
Initial Ordering Charge Special Access		\$74.15
Subsequent Ordering Charge Special Access		64.40
Service Installation Charge per SAL		174.61
Design Change Charge per ASR/Per Occurrence		16.99
Temporary Videoband Service		OCB
2. <i>Voiceband Facilities</i>		
a. Standard Arrangements		
	<u>Nonrecurring Charges</u>	<u>Monthly Rate</u>
Special Transport, per airline mile	---	\$4.50
Special Access Line		
Two-Wire	---	18.00
Four-Wire	---	36.00



**VI. SPECIAL ACCESS** (Continued)

b. Optional Arrangements	<u>Nonrecurring Charges</u>	<u>Monthly Rate</u>
Supplemental Features, per port		
Multi-point Data Bridging	\$81.41	\$4.00
Voice Conference Bridging	59.95	4.66
Alarm Distribution Bridging		
Common Equipment	455.16	20.63
Per Two-Wire Port	53.42	2.06
Conditioning Arrangements – Data per SAL		
Type C	457.47	1.77
Type DA	131.63	1.18
Signaling Arrangement per SAL		
Loop Signaling Range Extension	170.94	6.28
Loop or E&M to SF	274.22	14.67
E&M to DX	170.94	6.98
E&M to Loop	191.84	5.01
Loop or E&M to PCM	136.81	2.99
Automatic Ringdown	174.69	11.18
Echo Control – Echo Suppression per CKT	215.34	13.16
Echo Control – Echo Canceller per CKT	265.76	24.95
Voiceband Facility Switching Arrangement	170.94	3.08
Dataphone Select-a-station Bridging Common Equipment		
Addressable	2,872.90	175.31
Sequential	2,821.25	129.29
Each Four-Wire Port	166.33	12.03
Each Two-Wire Port	51.98	2.97
Improved Return Loss per SAL	84.36	2.04
Improved Termination Option per SAL	136.37	7.53
Improved ELEPL per SAL	104.32	2.32

**VI. SPECIAL ACCESS** (Continued)

<b>3. Program Audio (200-3500 Hz) Facilities</b>			
a. Standard Arrangements			
	<u>Nonrecurring Charges</u>	<u>Monthly Rate</u>	<u>Daily Rate</u>
Special Transport, per airline mile	---	\$4.50	\$.45
Special Access Line	---	36.88	3.69
b. Optional Arrangements			
	<u>Nonrecurring Charges</u>	<u>Monthly Rate</u>	<u>Daily Rate</u>
<u>Supplemental Features</u>			
Program Audio Bridging per Port	\$28.39	1.00	.10
Special Access Line	260.81	12.00	1.20
<b>4. Program Audio (100-5000 Hz) Facilities</b>			
a. Standard Arrangements			
	<u>Nonrecurring Charges</u>	<u>Monthly Rate</u>	<u>Daily Rate</u>
Special Transport, per airline mile	---	\$4.50	\$.45
Special Access Line	---	54.65	5.47
b. Optional Arrangements			
	<u>Nonrecurring Charges</u>	<u>Monthly Rate</u>	<u>Daily Rate</u>
<u>Supplemental Features</u>			
Program Audio Bridging per Port	\$28.39	1.00	.10
Conditioning – Program Audio-Zero Loss per SAL	260.81	12.00	1.20
<b>5. Program Audio (50-8000 Hz) Facilities</b>			
a. Standard Arrangements			
	<u>Nonrecurring Charges</u>	<u>Monthly Rate</u>	<u>Daily Rate</u>
Special Transport, per airline mile	---	\$4.50	\$.45
Special Access Line	---	56.10	5.61

**VI. SPECIAL ACCESS** (Continued)

b. Optional Arrangements			
<u>Supplemental Features</u>	<u>Nonrecurring Charges</u>	<u>Monthly Rate</u>	<u>Daily Rate</u>
Program Audio Bridging per Port	\$28.39	1.00	.10
Conditioning – Program Audio-Zero Loss per SAL	260.81	12.00	1.20
6. <i>Program Audio (50-15000 Hz) Facilities</i>			
a. Standard Arrangements			
	<u>Nonrecurring Charges</u>	<u>Monthly Rate</u>	<u>Daily Rate</u>
Special Transport, per airline mile	---	\$4.50	\$.45
Special Access Line	---	59.05	5.91
b. Optional Arrangements			
<u>Supplemental Features</u>	<u>Nonrecurring Charges</u>	<u>Monthly Rate</u>	<u>Daily Rate</u>
Program Audio Bridging per Port	\$28.39	1.00	.10
Conditioning – Program Audio-Zero Loss per occurrence	129.13	1.00	.10
Conditioning – Program Audio-Zero Loss per SAL	260.81	12.00	1.20

**VI. SPECIAL ACCESS** (Continued)

<b>7. High Capacity Digital DS1 (1.544 Mbps) Facilities</b>		
<b>a. Standard Arrangements</b>		
	<u>Nonrecurring Charges</u>	<u>Monthly Rate</u>
Special Access Line First System	\$900.00	\$201.21
Each Additional System	103.66	96.33
Special Transport Termination	---	19.31
Special Transport, per airline mile <sup>9</sup>	---	15.00
<b>b. Optional Payment Plan (OPP)<sup>10</sup></b>		
	<u>Nonrecurring Charges</u>	<u>Monthly Rate</u>
Special Access Line, per line (First and Additional Systems)		
One Year	---	\$192.00
Three Year	---	180.00
Five Year	---	167.00
Special Transport Termination	---	19.31
Special Transport, per airline mile <sup>8</sup>	---	15.00
<b>c. Optional Arrangements</b>		
	<u>Nonrecurring Charges</u>	<u>Monthly Rate</u>
Supplemental Features, per Special Access		
Automatic Protection Switching	\$892.18	\$113.22
Intrastate Rider on Customer's Optical Networking Facility		
DS1 Rider, per rider circuit	---	70.00

<sup>9</sup> Rate also applicable for Intraexchange Interoffice mileage.

<sup>10</sup> Promotion rates may apply. See Section XX. Promotions, High Capacity Digital DS1 (1.544 Mbps) OPP promotion.

**VI. SPECIAL ACCESS** (Continued)

<i>8. High Capacity Digital DS1C (3.152 Mbps) Facilities</i>		
<u>Standard Arrangements</u>	<u>Nonrecurring Charges</u>	<u>Monthly Rate</u>
Special Transport Termination	---	\$20.97
Special Transport, per airline mile	---	30.01
<i>9. High Capacity Digital Fiber Connection (6.312 Mbps) Facilities</i>		
<u>Fiber Connect Optional Payment Plan</u>	<u>Nonrecurring Charges</u>	<u>Monthly Rate</u>
Special Transport, per airline mile	---	<sup>11</sup>
Special Transport Termination	---	<sup>11</sup>
Special Access Line - Electrical Interface	\$1,000.00	
One Year		\$1,100.00
Three Year		800.00
Five Year		650.00
Optical Interface	1,000.00	
One Year		850.00
Three Year		550.00
Five Year		475.00

---

<sup>11</sup> In addition to the DSI Special Transport and Special Transport Termination rate elements (when applicable), as set forth in VI.G.10. for four (4) DS1 transported circuits.

**VI. SPECIAL ACCESS** (Continued)

10. High Capacity Digital Fractional T1 (FT1) Facilities		
a. Standard Arrangements	Nonrecurring Charges	Monthly Rate
(1) 2 x 56 Kbps or 2 x 64 Kbps Special Access Line	\$450.00	\$103.78
Special Transport per airline mile	---	5.50
Special Transport Termination	---	12.00
(2) 4 x 56 Kbps or 4 x 64 Kbps Special Access Line	\$450.00	111.59
Special Transport per airline mile	---	6.50
Special Transport Termination	---	18.00
(3) 6 x 56 Kbps or 6 x 64 Kbps Special Access Line	\$450.00	119.39
Special Transport per airline mile	---	7.50
Special Transport Termination	---	24.00

**VI. SPECIAL ACCESS** (Continued)

b. FT1 Optional Payment Plan	<u>Nonrecurring Charges</u>	<u>Monthly Rate</u>
(1) 2 x 56 Kbps or 2 x 64 Kbps Special		
Access Line	---	
One Year	---	\$100.00
Three Year	---	90.00
Five Year	---	80.00
Special Transport,		
per airline mile	---	5.50
Special Transport Termination	---	12.00
(2) 4 x 56 Kbps or 4 x 64 Kbps Special		
Access Line	---	
One Year	---	110.00
Three Year	---	99.00
Five Year	---	88.00
Special Transport,		
per airline mile	---	6.50
Special Transport Termination	---	18.00
(3) 6 x 56 Kbps or 6 x 64 Kbps Special		
Access Line	---	
One Year	---	119.00
Three Year	---	107.10
Five Year	---	95.20
Special Transport,		
per airline mile	---	7.50
Special Transport Termination	---	24.00
<b>11. High Capacity DS3 (44.736 Mbps) Facilities – Three System</b>		
	<u>Nonrecurring Charges</u>	<u>Monthly Rate</u>
<u>Electrical Interface</u>		
First Special Access Line		
One Year	\$2,500.00	\$5,500.00
Three Year	2,500.00	2,700.00
Five Year	2,500.00	2,400.00
Seven Year	2,500.00	2,305.00
Each Additional Special Access Line –		
Maximum of 2		
One Year	400.00	500.00
Three Year	400.00	400.00
Five Year	400.00	300.00
Seven Year	400.00	200.00

**VI. SPECIAL ACCESS** (Continued)

<i>12. High Capacity DS3 (44.736 Mbps) Facilities – Individual System</i>		
<u>Electrical Interface</u>	<u>Nonrecurring Charges</u>	<u>Monthly Rate</u>
Each Special Access Line		
One Year	900.00	1,400.00
Three Year	900.00	740.00
Five Year	900.00	650.00
Seven Year	900.00	610.00
<i>13. High Capacity DS3 (44.736 Mbps) Facilities – Optional Arrangement Rider</i>		
<u>Intrastate Rider on Customer's Optical Networking Facility</u>	<u>Nonrecurring Charges</u>	<u>Monthly Rate</u>
DS3 Rider, per rider circuit	---	\$240.00
<i>14. High Capacity DS3 (44.736 Mbps) Facilities – Special Transport</i>		
a. DS3 Special Transport Terminations		<u>Monthly Rate</u>
3 System or Individual Transport, per Termination		\$300.00
b. DS3 Special Transport Facilities		<u>Monthly Rate</u>
3 System or Individual Transport, per Termination		\$60.00
<i>15. High Capacity DS3 (44.736 Mbps) Facilities – DS3 Multiplexer Cross Connect Arrangement</i>		
		<u>Nonrecurring Charge</u>
DS3 Multiplexer Cross Connect Arrangement, per Arrangement		\$65.00



**VI. SPECIAL ACCESS** (Continued)

<b>16. Digital Data Service Facilities</b>		
<b>a. Standard Arrangements</b>		
	<u>Nonrecurring Charges</u>	<u>Monthly Rate</u>
Special Transport – All Speeds, per airline mile	---	\$4.50
Special Access Line – All Speeds	---	88.00
<b>b. Optional Arrangements</b>		
	<u>Nonrecurring Charges</u>	<u>Monthly Rate</u>
Supplemental Features, per Port DDS Bridging	\$18.17	\$9.29
<b>c. DDS Optional Payment Plan</b>		
	<u>Nonrecurring Charges</u>	<u>Monthly Rate</u>
Special Access Line – 2.4, 4.8, 9.6 and 19.2 Kbps		
One Year	---	\$98.00
Three Year	---	88.00
Five Year	---	78.00
Special Access Line – 56, 64 Kbps		
One Year	---	\$98.00
Three Year	---	88.00
Five Year	---	78.00

**VI. SPECIAL ACCESS** (Continued)

<i>17. Multiplexing Arrangements</i>		
	<u>Nonrecurring Charges</u>	<u>Monthly Rate</u>
Voice to Narrowband	\$5,665.81	\$262.94
DS1 to Voice	1,013.82	199.77
DS1C to Voice	8,349.12	548.60
DS1C to DS1	8,349.12	319.90
DS3 to DS1	450.00	490.00
Digital Data Carrier Multiplexer Common Equipment	1,500.38	177.00
Each 64 kbps per Port	245.97	14.78
Digital Data Subrate Multiplexer		
One 64 kbps to Twenty 2.4 kbps	1,078.84	188.65
One 64 kbps to Ten 4.8 kbps	1,072.30	139.69
One 64 kbps to Five 9.6 kbps	867.36	121.48
<i>18. High Voltage Protection</i>		
	<u>Nonrecurring Charges</u>	<u>Monthly Rate</u>
High Voltage Protection Device	\$500.00	\$108.22
High Voltage Protection Per Circuit Terminated	50.00	28.81
<u>H. Miscellaneous Special Access Services</u>		
Clear Channel Capability		
<i>1. Description of Service</i>		
<p>An arrangement that allows the customer to transport 1.536 Mbps of information through a DS1 with no constraint on the quantity or sequence of one (Mark) and zero (space) bits utilizing the Bipolar with Eight Zero Substitution (B8ZS) Method of providing bit sequence independence. This arrangement is capable of transporting DS1 signals which utilize Superframe or Extended Superframe Format (ESF) as defined by the American National Standards Institute (ANSI) T1.107-1988 standard. The installation interval for Clear Channel Capability may exceed standard intervals where equipment in the central office is not readily available. The charges apply on a per SAL basis.</p>		
<p>This arrangement requires the customer signal at the channel interface to conform to the B8ZS method of providing bit sequence independence, as described in ANSI T1.102-1987 and Section 6103 of the Industry Standard Technical Interface Reference Manual. The rates for Clear Channel Capability are found in VI.H.1..</p>		

**VI. SPECIAL ACCESS** (Continued)

2. Rates		
	<u>Nonrecurring Charges</u>	<u>Monthly Rate</u>
Clear Channel Capacity per SAL	\$83.00	\$24.26
I. <u>Special Access Cross Connect for EIS</u>		
		<u>Monthly Rate</u>
<u>Per DS0, DS1 or DS Connection</u>		
DS0		\$.98
DS1		3.68
DS3		31.93

## VII. MISCELLANEOUS SERVICES

<p><b>A. <u>General</u></b></p> <p>Miscellaneous Services available to the customer include the following:</p> <ol style="list-style-type: none"> <li>1. Additional Labor (i.e., Overtime Installation, Overtime Repair, Additional Installation Testing, Standby, Testing and Maintenance with Other Telephone Companies)</li> </ol>	
<ol style="list-style-type: none"> <li>2. Maintenance of Service</li> </ol>	
<ol style="list-style-type: none"> <li>3. Telecommunications Service Priority (TSP) System</li> </ol>	
<ol style="list-style-type: none"> <li>4. Presubscription</li> </ol>	
<ol style="list-style-type: none"> <li>5. Additional Testing</li> </ol>	
<ol style="list-style-type: none"> <li>6. Provision of FIA Information</li> </ol>	
<ol style="list-style-type: none"> <li>7. End User Lists</li> </ol>	
<ol style="list-style-type: none"> <li>8. Billing Name and Address Services</li> </ol>	
<p>These services are described in detail in <i>VII.B.</i> through <i>VII.I.</i>.</p>	
<p><b>B. <u>Additional Labor</u></b></p> <p>Additional Labor is that labor requested by the customer on a given FIA and agreed to by the Company as set forth in 1. through 5.. The Company will notify the customer that Additional Labor charges as set forth in 7. will apply before any Additional Labor is undertaken. Additional Labor charges will also apply if the requirement for the Additional Labor is the fault of the customer or parties on whose behalf it acts.</p> <ol style="list-style-type: none"> <li>1. <i>Overtime Installation</i></li> </ol> <p>Overtime installation is that Company installation effort outside the business day. Overtime rates will apply anytime outside the business day and all day Saturday. Premium time rates will apply all day Sunday and on all Company approved holidays. For applicable holidays in each jurisdiction contact Issuing Carrier identified on Section <i>I.</i>, Sheet 1.</p>	
<ol style="list-style-type: none"> <li>2. <i>Overtime Repair</i></li> </ol> <p>Overtime repair is Company repair which could have been performed during the normal business day, but that is delayed at the specific request of the customer to a later time period which is outside the normal business day or to a weekend day or holiday. The request will result in the application of overtime rates anytime outside the business day and all day Saturday. Premium time rates will apply on Sunday and Company approved holidays. These rates, as set forth in Section <i>VII.B.</i>, will only apply when there is a delay of repair at the request of the customer to the time periods stated above.</p>	

**VII. MISCELLANEOUS SERVICES** (Continued)

<p><b>3. Additional Installation Testing</b></p> <p>Additional installation testing is that testing performed by the Company at the time of installation which is in addition to normal pre-service and acceptance testing.</p>														
<p><b>4. Standby</b></p> <p>Standby includes all time in excess of one-half (1/2) hour during which Company personnel are available to make coordinated tests on a given FIA. The standby charge applies only when Company personnel must wait more than thirty (30) minutes beyond a prearranged, mutually agreed appointment time. Standby charges will cease when testing begins, or when Company personnel are released from the standby requirement, or when testing is rescheduled for a later date or time. Charges will not be applicable if Company personnel cause the delay.</p>														
<p><b>5. Testing and Maintenance with Other Telephone Companies</b></p> <p>Additional testing, maintenance, or repair of facilities which connect to facilities of other telephone companies, which is in addition to normal effort required to test, maintain, or repair facilities provided solely by the Company.</p>														
<p><b>6. Charges for Additional Labor</b></p> <table border="1" style="width: 100%; border-collapse: collapse;"> <thead> <tr> <th style="text-align: left;">Labor Periods</th> <th style="text-align: center;">First Half Hour or Fraction Thereof</th> <th style="text-align: center;">Each Additional Half Hour or Fraction Thereof</th> </tr> </thead> <tbody> <tr> <td>Basic Time, Business Day, per Technician</td> <td style="text-align: center;">\$29.79</td> <td style="text-align: center;">\$19.86</td> </tr> <tr> <td>Overtime, Outside the Business Day, per Technician<sup>12</sup></td> <td style="text-align: center;">36.26</td> <td style="text-align: center;">24.16</td> </tr> <tr> <td>Premium Time, Outside the Business Day, per Technician<sup>12</sup></td> <td style="text-align: center;">42.72</td> <td style="text-align: center;">28.47</td> </tr> </tbody> </table>			Labor Periods	First Half Hour or Fraction Thereof	Each Additional Half Hour or Fraction Thereof	Basic Time, Business Day, per Technician	\$29.79	\$19.86	Overtime, Outside the Business Day, per Technician <sup>12</sup>	36.26	24.16	Premium Time, Outside the Business Day, per Technician <sup>12</sup>	42.72	28.47
Labor Periods	First Half Hour or Fraction Thereof	Each Additional Half Hour or Fraction Thereof												
Basic Time, Business Day, per Technician	\$29.79	\$19.86												
Overtime, Outside the Business Day, per Technician <sup>12</sup>	36.26	24.16												
Premium Time, Outside the Business Day, per Technician <sup>12</sup>	42.72	28.47												
<p><b>C. Maintenance of Service Charge</b></p> <p>1. When a customer reports trouble to the Company for clearance, the customer shall be responsible for payment of a Maintenance of Service Charge when Company personnel are dispatched to the customer's location and no trouble is found in the Company's facilities. Failure of Company personnel to find trouble in Company facilities will result in no charge if the trouble is actually in those facilities, but not discovered at the time.</p>														

<sup>12</sup> A call out of a Company employee at a time not consecutive with the business day is subject to a minimum charge for four (4) hours.

**VII. MISCELLANEOUS SERVICES** (Continued)

<p>In this case, or in 2. following, no credit allowance will be applicable for the interruption involved, unless the trouble is found in the Company's facilities.</p>	
<p>2. The customer shall be responsible for payment of a Maintenance of Service Charge when the Company dispatches personnel to the customer's location and the trouble is in equipment or communications systems provided by other than the Company or in detariffed CPE provided by the Company.</p>	
<p>3. The Maintenance of Service Charge time period will begin when Company personnel are dispatched. This will only include the actual time required to reach the customer's location and perform an investigation. The time period will end when the investigation is finished. The labor charge as set forth in <i>Vii.B.6.</i> preceding will apply to Maintenance of Service at the appropriate Basic, Overtime or Premium rate. These charges apply whether the trouble is in the equipment of communications systems provided by other than the Company, or in detariffed CPE provided by the Company.</p>	
<p><b>D. <u>Telecommunications Service Priority (TSP) System</u></b></p>	
<p>1. <i>Description of the Service</i></p> <p>The TSP System is a service that provides for the priority provisioning and/or restoration of National Security Emergency Preparedness (NSEP) telecommunications services. The TSP system applies only to NSEP services, includes both Switched and Special FIA and provides the Company with a guide to the sequence in which services are to be provisioned and/or restored.</p>	
<p>All FIA that can be identified by a unique circuit identifier, can be provisioned for NSEP service by the Company.</p>	
<p>The rates and charges associated with a customer subscribing to the TSP System are as specified in Section <i>Vii.D.7.</i></p>	
<p>2. <i>Obtaining TSP System Service</i></p> <p>The Executive Office of the President, through the TSP Program Office, is empowered with the authority to receive, evaluate and process requests for NSEP services. The TSP Program Office makes the priority level assignments and issues the TSP authorization code reflecting the priority assignment associated with a request. The customer provides the TSP authorization code, in addition to all the other details necessary to complete the order (ASR), to the Company to obtain TSP System Service.</p>	
<p>The TSP authorization code, assigned on a per ASR basis, consists of a twelve (12) character field, a nine (9) character control ID followed by a dash and a two (2) character field specifying the priority level assignment. Its structure is as follows:</p> <p style="text-align: center;">TSPxxxxn-yy</p>	
<p>The "x"s represent a sequence of numbers unique to each TSP authorization code and the "n" is a one (1) character alphanumeric check digit. The first "y" contains the provisioning priority level assignment and the second "y" contains the restoration priority level assignment.</p>	

**VII. MISCELLANEOUS SERVICES** (Continued)

<p><b>3. Provisioning Priority</b></p> <p>If the customer requires service within a shorter time interval than the Company can provide, and the requested service qualifies for NSEP, the customer may elect to invoke NSEP treatment and obtain the appropriate provisioning priority assignment from the TSP Program Office. Acceptable assignment code values are: E, 1, 2, 3, 4, 5 or 0.</p>	
<p>The assignment of the value "E" denotes Emergency Provisioning and implies the service has the most critical provisioning requirements and the Company will respond accordingly. The Company will take immediate action to provide the requested service at the earliest possible date. Rates and charges associated with "E" provisioning are specified in Section VII.D.7..</p>	
<p>The assignment values of 1, 2, 3, 4 and 5 are treated as essential service priorities and the Company will adjust its available resources to meet the customer's requested due date. Rates and charges associated with invoking this priority treatment are specified in Section VII.D.7.. The value "0" implies no provisioning priority.</p>	
<p><b>4. Restoration Priority</b></p> <p>A TSP authorization code for restoration priority classifies the service as being among the nation's most important NSEP telecommunication services. The Company will restore these services before service without restoration priority assignments in the order of priority assignments. Acceptable values are: 1, 2, 3, 4, 5 or 0 with the value "1" being the highest priority.</p>	
<p>When the Company recognizes a TSP as being out of service, unusable or receives a trouble report, available resources will be dispatched to restore the service as quickly as practicable. A priority value of 1, 2 or 3 requires dispatch outside normal business hours if necessary to restore the service. A priority value of 4 or 5 only requires dispatch outside of normal business hours if the next business day is more than twenty-four (24) hours away. If the value "0" has been assigned, then no restoration priority is applicable to this service.</p>	
<p>The minimum period for service is one (1) month.</p>	
<p><b>5. Obligations of the Customer</b></p> <p>a. In all instances, the customer is responsible for obtaining the appropriate TSP authorization code and providing that code to the Company.</p>	
<p>b. The TSP System service customer must also be the customer for the FIA with which TSP service is associated. Only the customer or its authorized agent as indicated in a letter of agency on file with the Company is allowed to order TSP System service.</p>	
<p>c. All points of a multipoint service configuration must have the same restoration priority assignment and must satisfy the requirements of that assignment.</p>	
<p>d. In obtaining TSP System service, the customer consents to the release of certain information by the Company to the federal government in order to maintain and administer the TSP System. Such information includes: the customer's name, telephone number and mailing address, the TSP authorization code and the circuit or service ID number associated with the NSEP service.</p>	

**VII. MISCELLANEOUS SERVICES** (Continued)

<p>e. The Company will attempt to notify the customer of expected charges. The customer, when invoking NSEP treatment, recognizes that quoting charges and obtaining permission beforehand may not be practicable and may cause unnecessary delays and, as a result, grants the Company the right to quote and bill charges after provisioning of the service.</p>	
<p>f. During certain emergencies, the customer may request TSP assignments verbally and the Company will accept such verbal notification. The customer must submit a written order (ASR) to the Company within two working days following the verbal request. If written order (ASR) is not received within two (2) working days, all applicable rates and charges accumulated to date to provision TSP System service become immediately due and payable and the requested TSP priority is revoked.</p>	
<p>g. The customer must request and justify revalidation of all priority level assignments at least every three (3) years.</p>	
<p>h. Additionally, the NCS Manual 3-1-1, "Telecommunications Service Priority (TSP) System for National Security Emergency Preparedness (NSEP) Service User Manual", dated July 9, 1990, prescribes specific conditions which warrant NSEP Treatment and related procedures.</p>	
<p><b>6. Obligations of the Company</b></p>	
<p>a. The Company will allocate resources to ensure best efforts to provide NSEP services by the time required.</p>	
<p>b. The Company will work TSP System services in the order of their priority level assignments. The priority sequence is as follows:</p> <ul style="list-style-type: none"> <li>- Restore NSEP services assigned restoration priority 1</li> <li>- Provision Emergency (E) NSEP services</li> <li>- Restore NSEP services assigned restoration priority 2, 3, 4 or 5</li> <li>- Provision NSEP services assigned provisioning priority 1, 2, 3, 4 or 5.</li> </ul>	
<p>c. The Company will work cooperatively with other providers of NSEP service when only a portion is provided by the Company to ensure "end-to-end" service.</p>	
<p>d. Additionally, TSP System service will be provided in accordance with the guidelines set forth in NCS Handbook 3-1-2, "Telecommunications Service Priority (TSP) System for National Security Emergency Preparedness (NSEP) Service Vendor Handbook" dated July 9, 1990.</p>	



**VII. MISCELLANEOUS SERVICES** (Continued)

<p><b>7. Rates and Charges</b></p> <p>The following rates and charges are in addition to all other rates and charges that may apply for other services offered under this tariff which operate in conjunction with the TSP System.</p> <p>a. Establishment of TSP System Service</p> <p>The establishment of TSP System Service is a nonrecurring charge (NRC) specified below which applies when a FIA is ordered with provisioning and/or restoration priority. If both are ordered at the same time, only one NRC is applicable. The NRC is also applicable for orders changing priority levels.</p> <table style="margin-left: auto; margin-right: auto;"> <tr> <td style="text-align: center;">Nonrecurring Charge Per Circuit</td> </tr> <tr> <td style="text-align: center;">\$14.50</td> </tr> </table>	Nonrecurring Charge Per Circuit	\$14.50	<p>b. Provisioning Priority</p> <p>There are two basic levels of provisioning priority, Emergency (provisioning priority "E") and Essential (provisioning priority 1, 2, 3, 4 or 5).</p> <p>(1) Emergency Provisioning</p> <p>The Company will take immediate action to provide the requested service at the earliest possible date. The rates and charges will apply as set forth in Section XI., Special Construction.</p>
Nonrecurring Charge Per Circuit			
\$14.50			
	<p>(2) Essential Provisioning</p> <p>The Company will adjust its available resources to meet the customer's requested due date. The rates and charges will apply as set forth in Section IV.B.2.d..</p>		
<p>c. Restoration Priority</p> <p>Restoration Priority is a monthly rate per circuit for the ongoing administration and maintenance of the TSP System. This monthly rate only applies when a restoration priority code (1, 2, 3, 4 or 5) is specified in position twelve (12) of the authorization code.</p> <table style="margin-left: auto; margin-right: auto;"> <tr> <td style="text-align: center;">Monthly Rate Per Circuit</td> </tr> <tr> <td style="text-align: center;">\$4.90</td> </tr> </table>	Monthly Rate Per Circuit	\$4.90	
Monthly Rate Per Circuit			
\$4.90			

**VII. MISCELLANEOUS SERVICES** (Continued)

<p><b>E. <u>Presubscription</u></b></p> <p><b>1. <i>Pay Telephones – IntraLATA Equal Access</i></b></p> <p>Subject to the negotiation process between the payphone location provider and the Company, the payphone location provider, or his agent, may select, where technically feasible, an IC or LEC to place intrastate, intraLATA MTS/MTS-type calls without the 101XXXX access code. This IC or LEC is referred to as the payphone's IntraLATA Primary Interexchange Carrier (IPIC). All 1+ and 0+ intrastate, intraLATA calls will be routed to the IPIC.</p>	
<p><b>2. <i>IPIC Charge Application</i></b></p> <p>The Company will make post conversion changes in the end user's, end user agent's or reseller's IPIC assignment pursuant to an IC or LEC provided list of customers. Should an end user, end user agent or reseller dispute authorization of the change within two (2) years of the IPIC assignment, the Company will place the end user on the previous carrier network where possible and the carrier will be billed according to <i>VII.E.6.</i></p>	
<p><b>3. <i>Unauthorized Primary IntraLATA Carrier (IPIC) Restoral Change</i></b></p> <p>An Unauthorized IPIC Change is a change in the preferred IPIC IC that the end user or Pay Telephone Service Provider denies authorizing.</p>	
<p>If an end user or Pay Telephone Service Provider denies requesting a change of IPIC IC as submitted by the alleged unauthorized IC, the alleged unauthorized IC will be assessed the IPIC Charge as specified in <i>VII.E.10.</i> for:</p> <ul style="list-style-type: none"> <li>- Changing the end user or Pay Telephone Service Provider to the disputed IC, and</li> </ul>	
<ul style="list-style-type: none"> <li>- Placing the end user or Pay Telephone Service Provider on their previous IC network or the IC network of their choice.</li> </ul>	
<p>In accordance with the Federal Communications Commission's Slamming Liability Rules in FCC Docket 94-129, if an alleged unauthorized carrier is ultimately exonerated of liability, the alleged unauthorized IC is entitled to receive full payment from the end user or Pay Telephone Service Provider for all services provided. In such situations, any IPIC Charges assessed against the alleged unauthorized IC by the Company are subject to rebilling to the end user or Pay Telephone Service Provider by the alleged unauthorized IC.</p>	

**VII. MISCELLANEOUS SERVICES** (Continued)

<p><b>4. <i>IntraLATA Presubscription Charge</i></b></p> <p>In end offices converted to intraLATA Equal Access:</p> <p>a. New end users and multi-party end users who upgrade to individual lines must presubscribe to the IPIC of their choice at the time an order is placed for service. Upon the end user's selection of the IPIC a confirmation notice will be sent identifying the IC or LEC selected as the IPIC. From the date of the confirmation notice, the end user will have one hundred twenty (120) days to change his/her selection without charge. If an IPIC is not chosen at the time the order for service is submitted, the end user will be sent a notice which contains a list of ICs and LECs providing intraLATA service, and will be informed that they have one hundred twenty (120) days to contact the IC or LEC of their choice to apply for the IPIC arrangement.</p>	
<p>If notice is received by the Company within one hundred twenty (120) days of the in-service date for local service or upgrade, no charge will be billed to the end user. If notice is received after one hundred twenty (120) days, the end user will be billed the nonrecurring charge for the IPIC specified in <i>VII.E.10.</i>. Until the end user receives service from the selected carrier, he/she may access the carrier of his/her choice by dialing the appropriate 101XXXX carrier identification code.</p>	
<p>b. For existing end users, the first IPIC change, and a subsequent IPIC change, made prior to January 9, 1998 will be made without charge. After January 8, 1998 the first IPIC change will be made without charge, and subsequent IPIC changes will be made per the charge as specified in <i>VII.E.10.</i>.</p>	
<p><b>5. <i>Liability of the Company</i></b></p> <p>If through the fault of the Company, the end user, end user agent or reseller is not subscribed to its chosen PIC, the nonrecurring charges in <i>VII.E.10.</i> do not apply to reassign the end user, end user agent or reseller to his chosen IPIC.</p>	
<p><b>6. <i>Carrier Desired Due Date (ICDDD) for IPIC Installation</i></b></p> <p>An IC or LEC may request a desired due date for IPIC installation for a specific, single end user, end user agent or reseller acting on behalf of an end user post equal access conversion. This ICDDD is a mutually agreed upon negotiated due date, determined to be between three (3) and forty-five (45) business days from the date of receipt of the order. The carrier must coordinate the ICDDD with the Company prior to sending in the first order.</p>	
<p>The ICDDD does not apply to routine lists provided by the carrier. The Nonrecurring Charge for IPIC as found in <i>VII.E.10.</i>, applies to each line converted to the carrier requesting ICDDD. This charge will be billed to the carrier's end user customer.</p>	

**VII. MISCELLANEOUS SERVICES** (Continued)

<p><b>7. Rates and Charges</b></p> <p>Nonrecurring Charge for Primary IntraLATA Carrier (IPIC)</p> <p>The nonrecurring charge for IPIC is as follows:</p> <table style="width: 100%; border: none;"> <tr> <td style="width: 70%;"></td> <td style="text-align: right; vertical-align: bottom;"><u>Nonrecurring Charge</u></td> </tr> <tr> <td>Per Company Local Service Link or Trunk</td> <td></td> </tr> <tr> <td>NAAPC (IPIC)</td> <td style="text-align: right; vertical-align: bottom;">\$4.35</td> </tr> </table>		<u>Nonrecurring Charge</u>	Per Company Local Service Link or Trunk		NAAPC (IPIC)	\$4.35	
	<u>Nonrecurring Charge</u>						
Per Company Local Service Link or Trunk							
NAAPC (IPIC)	\$4.35						
<p><b>F. Additional Testing</b></p> <p>The Company will perform acceptance testing as specified in Section V. and Section VI.A.5. to insure that FIA ordered by the customer are functioning properly, prior to turning over such FIA to the customer. In addition, the Company will perform ongoing tests as specified in Section V., respectively, to assure the continued satisfactory performance of Switched Access Services ordered by the customer.</p>							
<p>Testing offered under this section of the tariff is in addition to those tests described above and will be provided, when requested by the customer, at an additional charge.</p>							
<p>Testing is provided by Company personnel at Company locations. However, provisions are made in VI.F.1.e. and VI.F.2.b., to allow a customer to request Company personnel to perform testing at the CDL or the end user premises.</p>							
<p>Additional testing is provided on a scheduled or nonscheduled basis. Scheduled testing shall be performed on a predetermined time basis to allow for cost efficient utilization of Company and customer resources. Scheduled testing should be based on a one (1) year period. Nonscheduled tests are performed by the Company on a request-by-request basis, not in conjunction with any fixed schedule.</p>							
<p>The offering of testing under this section of the tariff is made subject to the availability of the necessary qualified personnel and test equipment at the various test locations mentioned in 1., 2., and 3. following.</p> <p><b>1. Switched Access Testing</b></p> <p>Testing for Switched Access is comprised of 1.) tests which are performed during the installation of Switched Access (i.e., acceptance tests) and 2.) tests which are performed after acceptance of such Switched Access by a customer (i.e., in-service tests).</p>							
<p>These tests are performed on a scheduled or nonscheduled basis, and may be conducted on an automatic, cooperative, or manual basis, as defined in a., b., c., d., and e. following.</p>							
<p>Additional Cooperative Acceptance Testing (ACAT) of Switched Access involves the Company provision of a technician at its office(s) and the customer provision of a technician at its CDL, with suitable test equipment to perform the required tests.</p>							

**VII. MISCELLANEOUS SERVICES** (Continued)

<p>a. Additional Cooperative Acceptance Testing may apply when the customer requests additional tests not specified in Section V..</p>	
<p>The labor charges as set forth in VII.B.6. preceding will apply to Additional Cooperative Acceptance Testing at the appropriate Basic, Overtime, or Premium rate.</p>	
<p>b. Automatic Scheduled Testing (USOC – UBGXT)</p> <p>Automatic Scheduled Testing (AST) of FGB, FGC, FGD, BSA-B, BSA-C, BSA-D and SAC Access is provided, as specified in Section V., where the customer provides remote office test lines and one hundred five (105) test lines with associated responders or their functional equivalent. AST charges will apply when such testing is requested on a more frequent basis than is provided for in accordance with the Company's Central Office Maintenance Planning System (COMPS). The customer may specify a more frequent schedule of tests at least sixty (60) days prior to the start of the prescribed schedule. Trunks from a Company digital switch, to a customer digital switch, utilizing digital facilities, are excluded from mandatory routine testing. The rates in VII.F.3.a. will apply to additional AST.</p>	
<p>The Company will provide a monthly AST report that lists the trunks within each Central Office access group that failed to meet established requirements. Trunk test failures requiring customer participation for trouble resolution will be provided to the customer on an as-occurs basis. A monthly report that lists the test results will be provided to the customer.</p>	
<p>c. Additional Cooperative Scheduled Testing (USOC-UBSXT:UBSCD)</p> <p>Additional Cooperative Scheduled Testing (ACST) of FGA, FGB, FGC, FGD, BSA-A, BSA-B, BSA-C, BSA-D and SAC Access Service occurs when the Company provides a technician at its office(s) and the customer provides a technician at its CDL, with suitable test equipment to perform the required tests. ACST charges will apply when loss/noise/balance testing or gain-slope testing is requested on a more frequent basis than is provided for in accordance with the Company's Central Office Maintenance Planning System (COMPS). ACST charges also apply when additional tests are requested for FGA, FGB, FGC, FGD, BSA-A, BSA-B, BSA-C, BSA-D or SAC Access Service that are not specified in Section V.. The customer may specify a more frequent schedule of tests sixty days prior to the start of the prescribed schedule. The rates in VII.F.3.b. will apply for additional ACST.</p>	
<p>The Company will provide, on a quarterly basis, an ACST report that lists the test results and the number of trunks that passed or failed. Trunk test failures requiring customer participation for trouble resolution will be provided to the customer on an as-occurs basis.</p>	

**VII. MISCELLANEOUS SERVICES** (Continued)

<p>d. Additional Manual Scheduled Testing</p> <p>Additional Manual Scheduled Testing (AMST) of FGA, FGB, FGC, FGD, BSA-A, BSA-B, BSA-C, BSA-D or SAC Access Service occurs when the Company provides a technician at its office(s) and at the CDL. AMST charges will apply when loss/noise/balance testing or gain-slope testing is requested on a more frequent basis than is provided for in accordance with the Company's Central Office Maintenance Planning System (COMPS). AMST charges also apply when additional tests are requested for FGA, FGB, FGC, FGD, BSA-A, BSA-B, BSA-C, BSA-D or SAC Access Service that are not specified in Section V.. The customer may specify a more frequent schedule of tests sixty days prior to the start of the prescribed schedule. The rates in <i>Vii.F.3.c.</i> will apply to additional AMST.</p>	
<p>The Company will provide, on a quarterly basis, an AMST report that lists the test results and the number of trunks that passed or failed. Trunk test failures requiring customer participation for trouble resolution will be provided to the customer on an as-occurs basis.</p>	
<p>e. Nonscheduled Testing</p> <p>Nonscheduled Testing (NST) will be performed "on demand" which results in the measurement of Switched Access. NST charges will apply only when testing is requested more frequently than is provided for in accordance with COMPS, or when a specific test is requested that is not normally performed. Tests for Switched Access, which are normally performed are contained in Section V.. Nonscheduled Testing (NST) of Switched Access may consist of the following testing arrangements:</p> <ul style="list-style-type: none"> <li>- the customer provides remote office test lines and one hundred five (105) test lines with associated responders or their functional equivalent (automatic testing), or</li> </ul>	
<ul style="list-style-type: none"> <li>- the Company provides a technician at its office(s) and the customer provides a technician at its CDL with suitable test equipment to perform the required tests (cooperative testing), or</li> </ul>	
<ul style="list-style-type: none"> <li>- the Company provides a technician at its office(s), and at the CDL or end user premises with suitable test equipment to perform the required tests (manual testing).</li> </ul>	
<p>Nonscheduled Tests may consist of any tests which the customer may require. The rates as set forth in <i>Vii.F.3.a.</i> following will apply to Nonscheduled Automatic Testing. The labor charges as set forth in <i>Vii.B.6.</i> preceding will apply to Nonscheduled Cooperative and Manual FIA Testing at the appropriate Basic, Overtime, or Premium rate.</p>	
<p>If nonscheduled tests are required and trouble is found in the Company facilities, charges for testing the Company facilities will not apply. If, however, trouble is found in the customer equipment, charges as set forth in <i>Vii.F.3.a.</i> and labor charges as set forth in <i>Vii.B.7.</i> are applicable.</p>	
<p>f. Obligations of the Customer</p> <p>(1) The customer shall provide the Remote Office Test Line priming data to the Company, as appropriate, to support AST as set forth in <i>Vii.F.1.b.</i> or NST as set forth in <i>Vii.F.1.e.</i></p>	

**VII. MISCELLANEOUS SERVICES** (Continued)

<p>(2) The customer shall make the facilities to be tested available to the Company at times mutually agreed upon.</p>	
<p><b>2. Special Access Testing</b></p> <p>The Company will, at the request of a customer, provide assistance in performing specific tests requested by the customer, however, the Company will only perform maintenance testing for its facilities within the LATA.</p> <p>a. Additional Cooperative Acceptance Testing</p> <p>When a customer provides a technician at its CDL or at the end user premises, with suitable test equipment to perform the required tests, the Company will provide a technician at its office for the purpose of conducting Additional Cooperative Acceptance Testing (ACAT). The labor charges as set forth in <i>VII.B.6.</i> preceding will apply to ACAT at the appropriate Basic, Overtime, or Premium rate.</p>	
<p>Additional Cooperative Acceptance Testing charges will apply when the customer requests tests which are not required to meet the transmission performance parameters as set forth in the Company Technical Interface Reference Manual.</p>	
<p>b. Nonscheduled Testing</p> <p>When a customer provides a technician at its CDL or at the end user premises, with suitable test equipment to perform the required tests, the Company will provide a technician at its office (cooperative testing) for the purpose of conducting Nonscheduled Testing (NST). Nonscheduled testing may consist of any test (e.g., loss, noise, slope, envelope delay, etc.) which the customer may request. If such testing indicates trouble in Company facilities, then the customer will not be charged. NST charges will apply if the trouble is in the facilities of the customer. At the customer's request, the Company will provide a technician at the CDL or at the end user premises (manual testing). The labor charges as set forth in <i>VII.B.6.</i> preceding will apply to Nonscheduled Testing at the appropriate Basic, Overtime, or Premium rate.</p>	
<p>c. Obligation of the Customer</p> <p>When the customer subscribes to Testing as set forth in this section, the customer shall make the facilities to be tested available to the Company at times mutually agreed upon.</p>	

**VII. MISCELLANEOUS SERVICES** (Continued)

3. <i>Rates and Charges</i>	
	<u>Rate</u>
a. Additional Automatic Scheduled Testing	
Basic Offering to First Point of Switching per Transmission Path, per Month	\$.45
b. Additional Cooperative Scheduled Testing	
Basic Offering to First Point of Switching per Transmission Path, per Month	1.69
Gain-Slope-To First Point of Switching per Transmission Path, per Month	.72
c. Additional Manual Scheduled Testing	
Basic Offering to First Point of Switching per Transmission Path, per Month	3.37
Gain-Slope-To First Point of Switching per Transmission Path, per Month	1.43
<b>G. <u>Provision of FIA Billing Information</u></b>	
<p>The customer will receive its monthly bills in paper format. At the option of the customer, its monthly bills may be provided on magnetic tape. When call detail is transmitted via magnetic tape, a charge will apply on a per tape and per record of detail entered basis. The provision of the bills on magnetic tape will be at an additional charge to the customer described below.</p>	
	<u>Charge</u>
Provision of FIA Billing Information in Magnetic Tape Format	
Per Tape	\$50.00
Per Record	.01



**VII. MISCELLANEOUS SERVICES** (Continued)

<p><b>H. End User List</b></p> <p><b>1. Presubscription List</b></p> <p>IntraLATA Equal Access:</p> <p>Prior to conversion to intraLATA equal access an IC or LEC may request a list of the Company's end users of record served from that end office switch. A single Presubscription List will be provided to intraLATA toll providers as follows:</p> <p>a. The Company will provide a list from its Customer data base. The list may be provided on magnetic tape, electronic transmission or paper printout, at the option of the IC or LEC, at rates provided in <i>VII.H.4.a.</i>. Foreign listings, PBX stations, public coin stations and numbers not in service will not be provided.</p> <p>(1) The Initial List will be provided to the IC or LEC no later than thirty (30) days after receipt of the order and payment by the IC or LEC of charges in <i>VII.H.3.a.</i>. The nonrecurring charge for the Initial List applies per order. A single order may contain all end offices having the same intraLATA equal access conversion date. The telephone number will not be provided if an end user has a nonpublished number.</p>	
<p>(2) The Account Activity List, which includes a listing of all changes to the customer data base, since the Initial List was produced, will be provided on a cyclic basis. The Account Activity List will only include information for those end users that are presubscribed to the IC or LEC (including end users with nonpublished numbers) for the sole purpose of updating the IC's or LEC's customer account information. There is no charge for this list.</p>	
<p>b. The IC or LEC agrees to use the Initial and Account Activity Lists for the sole purpose of contacting potential customers, or existing customers, regarding intraLATA telecommunications services available through equal access to be obtained from the Company. The IC or LEC agrees not to sell, or reproduce in any manner, in whole or in part, the lists or permit such to be done.</p>	
<p>c. The IC or LEC shall indemnify, protect and save harmless the Company from and against any and all loss, liability, damages and expense arising out of any demand, claim, suit or judgment for damages which may arise out of the Company's supplying of listing information, services or records.</p>	
<p>d. The Company and the IC or LEC agree that the mutual objective of the parties is to conduct their respective businesses to avoid confusion by the end users as to the separate and independent identity of the respective companies and their services. Neither the Company nor the IC or LEC shall make any representation to end users, the public, prospective advertisers, expressed or implied, written or oral, which would imply that the IC or LEC is the same as, a part of, or associated with the Company.</p>	
<p>e. This service may be terminated by either the Company or the IC or LEC upon thirty (30) days' written notice. The Company reserves the right to terminate this service immediately upon written notice if the IC or LEC misuses the list information. Performance by the Company shall be excused in the event of strike, riot, act of God or any other cause beyond the reasonable control of the Company.</p>	

**VII. MISCELLANEOUS SERVICES** (Continued)

<p><b>2. Snapshot List</b></p> <p>The Snapshot List is a summary of selected end user information for a specific IC or LEC which resides in the Company Customer data base. The Snapshot List may be provided on magnetic tape, electronic transmission or paper printout, at the option of the IC or LEC, at rates provided in VII.H.2.a.. Foreign listings, PBX stations, and numbers not in service will not be provided.</p>							
<p>The Snapshot List will be provided to the IC or LEC no later than thirty (30) days after receipt of the order. The nonrecurring charge for the Snapshot List applies per order.</p>							
<p>The purpose, liability and objectives associated with the provision of the Snapshot List is in VII.H.1.b.(2), (3), and (4).</p>							
<p><b>3. Rates and Charges</b></p> <table border="0" style="width: 100%;"> <thead> <tr> <th style="text-align: left;"><u>Snapshot List</u></th> <th style="text-align: right;"><u>Charge</u></th> </tr> </thead> <tbody> <tr> <td>Nonrecurring Charge, per order</td> <td style="text-align: right;">\$75.00</td> </tr> <tr> <td>Snapshot List, per listing</td> <td style="text-align: right;">.05</td> </tr> </tbody> </table>	<u>Snapshot List</u>	<u>Charge</u>	Nonrecurring Charge, per order	\$75.00	Snapshot List, per listing	.05	
<u>Snapshot List</u>	<u>Charge</u>						
Nonrecurring Charge, per order	\$75.00						
Snapshot List, per listing	.05						
<p><b>I. <u>Billing Name and Address Services (BNAS)</u></b></p> <p>The Company will, upon request, provide Billing Name and Address Services (BNAS) to a Telecommunications Service Provider (customer), or its authorized billing and collection agent. Telecommunications Service Providers are described in OAR 860-32-005.</p>							
<p>There are three (3) BNAS offerings available pursuant to this tariff, Billing Name and Address (BNA), Data Gathering Service (DGS), and End User Validation List.</p> <p><b>1. <i>BNA and Data Gathering Services</i></b></p> <p>BNA is the billing name and address information and Data Gathering is the billing telephone number, name, address and associated working telephone number information for customer- provided ten digit end user telephone numbers required by the Telecommunications Service Provider customer to bill for calls placed within a specific time period. BNA and DGS are offered subject to the conditions specified in the following:</p> <p>a. A standard format for the receipt and provision of telephone number and billing name and address information will be established by the Company. Charges for each BNA searched for and found or searched for and not found will be billed at rates in VII.I.3.a.. Charges for each record accessed for DGS are in VII.I.3.b.. BNA and DGS will be provided via magnetic tape, electronic transmission, or paper format, at the option of the customer, at rates in VII.I.3.a. and VII.I.3.b.. The processing fee will be applied once per calendar year for BNAS processing done within that calendar year.</p>							
<p>b. The customer must order BNA or DGS and provide test data tape at least thirty (30) days prior to delivery of the first customer order.</p>							

**VII. MISCELLANEOUS SERVICES** (Continued)

<p>c. The frequency for receipt of the customer-provided orders for BNA or DGS will be no more than twice monthly and at intervals mutually agreed upon between the Company and the customer. The customer provided end user telephone numbers will be programmed by the Company with the proper end user's billing name and address contained in the Company's file at that time.</p>	
<p>d. BNA and DGS information for nonlisted/nonpublished end user telephone numbers will be provided unless the nonlisted/nonpublished end user provides notice of nonconsent to the Company for the release of the BNA/DGS data. Within thirty (30) days of receipt of such notice, the Company will discontinue disclosure of the nonlisted/nonpublished BNA/DGS data.</p>	
<p>e. For other than electronic transmission, the output records will be sent to the customer via first class U. S. Mail. The output records will normally be made available for mailing ten (10) work days after receipt of the customer order or at an interval mutually agreed upon. Availability may be delayed in case of input errors in the customer provided order.</p>	
<p>f. The customer may request data be transmitted. Data transmission charges will be determined on an ICB. Data transmission hardware and software specifications will be mutually agreed upon by the Company and the customer.</p>	
<p>g. BNA and DGS detail will not be retained by the Company longer than forty-five (45) days. If the customer requests that the output be made available on a second occasion, such request must occur within thirty (30) days from the date the first was made.</p>	
<p>h. Any customer, provided BNA or DGS pursuant to this tariff, agrees to abide by all applicable rules, decisions, orders, statutes and laws concerning the disclosure of published and nonpublished telephone numbers, and further agrees to use the information contained therein only for the purpose of billing for services provided to their end users.</p>	
<p>i. In no case shall any customer or authorized billing and collection agent of a customer disclose the billing name and address information of any subscriber to any third party, except that a customer may disclose BNA/DGS information to its authorized billing and collection agent or to governmental law enforcement agencies upon receipt of the appropriate legal documentation.</p>	
<p>j. Conditions regarding refusal or discontinuance of this service are found in <i>III.A.8.</i></p>	
<p><b>2. End User Validation List</b></p> <p>End User Validation Lists provide for the disclosure of all or a portion of end user/agent data available from the Company's records to a Telecommunications Service Provider (customer), for purposes other than billing, and in compliance with the conditions specified in 47 CFR § 64.1201(c)(1). In addition, End User Validation List Service is offered subject to the conditions specified in <i>VII.I.1.</i>, and the following:</p> <p>a. Standard End User Validation Lists will be provided in three (3) files, business, coin (semi-public, public access and public paystations) and residence. Nonlisted/nonpublished information will be excluded, with the exception of nonlisted public paystations. The lists may be ordered for any of the Company's jurisdictions subject to this tariff, unless prohibited by federal regulation, federal statute, state regulation or state statute. Rates for the standard End User Validation List are in <i>VII.I.3.c.</i></p>	

**VII. MISCELLANEOUS SERVICES** (Continued)

b. Per calendar year, the customer may request up to two (2) lists for business, coin, and residence listings.	
c. A standard format will be established by the Company. Requests for special list sorts will be limited to an end user list separating those that are pre-subscribed to the requesting customer, and/or those that are not. The rate, per record, applicable to special sorts is in <i>VII.1.3.c.</i> .	
d. Each request shall be treated as a new request. Requests for updates from previous lists will not be provided.	
e. The customer shall have fifteen (15) business days from the date of delivery of a list to request any investigation of issues arising from the provision of the list.	
f. End User Validation Lists will normally be provided to the customer within thirty calendar days after receipt of a request and within ten (10) business days of extraction, or at an interval mutually agreed upon. The administrative fee specified under <i>VII.1.3.c.</i> applies per request.	
g. Conditions regarding refusal or discontinuance of this service are found in <i>III.A.8.</i>	

**VII. MISCELLANEOUS SERVICES** (Continued)

3. Rates and Charges	
	<u>Charge</u>
a. Billing Name and Address	
BNA Number Found, each per call	\$.25
BNA Number Not Found, each per call	.25
Processing Fee <sup>13</sup>	
Paper Report, Electronic Transmission, or Magnetic Tape, each	50.00
b. Data Gathering Service	
Per Record Accessed	.18
Processing Fee <sup>13</sup>	
Paper Report, Electronic Transmission, or Magnetic Tape, each	75.00
c. End User Validation List	
Standard Sort, per record provided	.034
Special Sort, per record provided	.054
Administrative Fee	
Paper Report, Electronic Transmission, or Magnetic Tape, per request	78.00

---

<sup>13</sup> Applies once per calendar year for BNA or DGA processing done within that calendar year.

### VIII. SPECIALIZED FIA OR ARRANGEMENTS

<u>General</u>  Specialized FIA or Arrangements may be provided by the Company, at the request of a customer, on an Individual Case Basis (ICB) if such FIA or arrangements meet the following criteria:  - The requested FIA or arrangements are not offered under other sections of this tariff.	
- The facilities utilized to provide the requested FIA or arrangements are of a type normally used by the Company in furnishing its other services.	
- The requested FIA or arrangements are provided within a LATA.	
- The requested FIA or arrangements are compatible with other Company services, facilities, and its engineering and maintenance practices.	
This offering is subject to the availability of the necessary Company personnel and capital resources.	

## IX. ANCILLARY SERVICES

<p><b>A. <u>Service Offerings</u></b></p> <p>Ancillary Services are available in the following categories:</p> <p>1. <i>Billing and Collection Services</i></p> <ul style="list-style-type: none"><li>- Call Recording Service</li><li>- Message Processing Service</li><li>- Assembly and Editing Service</li><li>- Call Record Provision Service</li><li>- Message Bill Processing Service</li><li>- Bill Rendering Service</li><li>- Message Investigation Service</li><li>- Online Bill Pay</li><li>- Fundamental Billing</li><li>- Bill Processing and Collection Service</li><li>- Invoice Billing Service</li><li>- Program Development</li><li>- Inquiry Service</li></ul>	
<p>2. <i>Operator Services</i></p> <ul style="list-style-type: none"><li>- Operator Transfer Service</li></ul>	
<p>Regulations, rates and charges as follows apply to Ancillary Services and shall not serve as a substitute for customer tariff offerings of services to end users. The provision of such Ancillary Services by the Company, as set forth following, does not constitute a joint undertaking with the customer for the furnishing of any service.</p>	
<p>The Company's undertaking to provide Ancillary Services is made only in conjunction with intrastate services offered within its operating territory.</p>	
<p>The regulations, rates and charges contained herein are in addition to the applicable regulations, rates and charges specified in other sections of this tariff and in other tariffs of the Company which are referenced herein.</p>	
<p><b>B. <u>Regulations</u></b></p> <p>1. <i>Undertaking of the Company</i></p> <p>a. Provision of Ancillary Services</p> <p>(1) The Company, to the extent Ancillary Services are, or can be made available with reasonable effort, will provide to the customer Ancillary Services as described in IX.C., at rates and charges as specified in the Company Price List for Ancillary Services.</p>	

**IX. ANCILLARY SERVICES** (Continued)

<p>(2) When the customer subscribes to Call Recording Service, as set forth in IX.C.1.a., and customer message detail is not available because the Company lost or damaged tapes or incurred recording system outages, the Company will estimate the volume of lost customer messages and associated revenue based on previously known values determined from historical data. In such events the extent of the Company's liability for damages shall be limited to the granting of a corresponding credit adjustment on the customer's bill representing amounts due to the customer for the unbilled revenue.</p>	
<p>When the Company is notified that, due to error or omission, incomplete data has been provided to a customer, the Company will make every reasonable effort to locate and/or recover the data and provide new magnetic tapes to the customer at no additional charge. Such request to recover the data must be made within thirty (30) days from the date and details were initially made available to the customer. If the data cannot be recovered, the extent of the Company's liability for damages shall be limited as set forth in the preceding paragraph.</p>	
<p>(3) The Company shall be responsible for contacts and arrangements with the end user concerning the billing, collecting, crediting and adjusting of the customer's service charges, when the Company provides Inquiry Service as set forth in IX.C.1.k..</p>	
<p>(4) Message Bill Processing, Bill Rendering, Online Bill Pay Service, Fundamental Billing and Inquiry Services will only be offered by the Company with the purchase of receivables. The Company will purchase the customer's receivables at a discount from face value. The exact contents of the discount factor and specific settlement procedures will be contained in individual contractual arrangements signed by each customer.</p>	
<p>b. Discontinuance and Refusal of Ancillary Services</p> <p>(1) If the customer fails to comply with the provisions of this tariff, including any payments to be made by it on the dates or at the times herein specified, and fails within thirty (30) days after written notice via certified mail from the Company may discontinue the provision of the Ancillary Service. In case of such discontinuance, all applicable charges shall immediately become due.</p>	
<p>(2) If the customer repeatedly fails to comply with the provisions of this tariff in connection with the provision of Ancillary Services and fails to correct such course of action after notice as set forth in (1) preceding, the Company may refuse applications for additional Ancillary Services.</p>	
<p>2. <i>Obligations of the Customer</i></p> <p>a. References to the Company</p> <p>The customer may advise end users that Ancillary Services are provided by the Company in connection with the service the customer furnishes to its end users.</p>	



**IX. ANCILLARY SERVICES** (Continued)

<p>b. Request for Service</p> <p>(1) Minimum Order Periods</p> <p>The customer shall order Ancillary Service(s) with the following minimum requirements:</p>	
<p>The minimum period for which Call Recording Service is provided and for which charges apply is one (1) month (thirty (30) days). A customer may cancel Call Recording Service on any date prior to the start of the next month's service. If written notice is not received from the customer, or from the telephone company that ordered the Call Recording Service prior to the start of the following month's service, the Company shall assume that the service is to be extended for another month (thirty (30) days).</p>	
<p>The initial minimum period for Message Processing, Message Bill Processing, Bill Rendering, Online Bill Pay, Fundamental Billing and Inquiry Services is three (3) years. Six (6) months prior to the end of the initial order period or subsequent extension, the customer shall notify the Company in writing, if the service is to be discontinued. If no notice is received from the customer, the Company shall assume that the service is extended for another year.</p>	
<p>(2) Order Requirements</p> <p>When Call Recording Service is ordered, the customer shall furnish the Company an estimate of the number of messages (message capacity) to be recorded. When Call Recording Service is provided from an end office switch, the estimate of the number of messages to be recorded shall be provided by end office. When Call Recording Service is provided from an access tandem, the estimate of the number of messages to be recorded shall be provided by access tandem. The message capacity shall be provided by year.</p>	
<p>When Message Processing Service is ordered, the customer shall furnish the Company an estimate of the number of messages (message capacity) to be processed. The number of messages shall be provided by year.</p>	
<p>When Message Bill Processing, Message Investigation, Online Bill Pay, Fundamental Billing and Inquiry Services are ordered for MTS/WATS services, the customer shall furnish the Company an estimate of the number of messages (message capacity) to be billed. The message capacity shall be provided by year. Separate estimates shall be furnished by the customer for MTS messages, bulk-billed messages (WATS/800/888 services) and Fundamental Billing messages.</p>	
<p>When Bill Rendering Service is ordered, the customer shall furnish the Company an estimate of the number of bills for which Bill Rendering Service will be provided. The bill capacity shall be provided by year. Separate estimates shall be furnished by the customer for MTS bills, bulk billed bills (WATS/800/888) and Fundamental Billing bills.</p>	

**IX. ANCILLARY SERVICES** (Continued)

<p>3. <i>Payment Arrangements</i></p> <p>a. Minimum Charges</p> <p>(1) Call Recording, Message Processing, Message Bill Processing, Online Bill Pay, Fundamental Billing and Inquiry Services are subject to minimum charges.</p>	
<p>(2) Any minimum billing associated with the above services will be filed on an individual case basis in Section <i>II.A.1.b.</i> of the Company Price List for Ancillary Services.</p>	
<p>b. Cancellation of Order for Ancillary Services</p> <p>(1) When an order for Ancillary Services is canceled prior to the start of installation of such Ancillary Services, no charges will apply. Installation of Ancillary Services is considered to have started when the Company incurs any cost in connection therewith or in preparation thereof which would not otherwise have been incurred.</p>	
<p>(2) Where program development of Ancillary Services has been started prior to the cancellation, and to the extent the Company has another use for the specially developed Ancillary Services, no charge applies. When the Company has no other use for the specially developed Ancillary Services, a charge equal to the costs incurred prior to the date of cancellation applies. Such charge is determined as detailed in paragraph c..</p>	
<p>The charge, as specified in paragraph (2), includes the cost, less the net salvage value of equipment and material either ordered, provided or installed, plus the nonrecoverable cost of system development and installation. Charges will be determined on an individual case basis as required and will be specified in <i>II.A.1.b.</i> of the Company Price List for Ancillary Services.</p>	
<p>c. Acceptance of Gift Certificates</p> <p>The Company will accept customer gift certificates for payment from end users, if the customer agrees in writing to redeem all such gift certificates.</p>	
<p>d. Minimum Period Disconnect Charges</p> <p>Minimum period disconnect charges will apply, if service is discontinued prior to the expiration of the minimum period. For Call Recording Service, the Company will use the most recent thirty (30) day period for which data is available to determine the total minimum monthly charge. The customer will only be billed for the adjusted amount due, if payment has been received for any portion of the discontinued service.</p>	
<p>If, for Message Processing, Message Bill Processing, Bill Rendering, Online Bill Pay, Fundamental Billing and Inquiry Services, service is discontinued prior to the end of the period ordered, the customer will pay the minimum charges for the remaining months of the minimum order period specified in <i>IX.B.2.b.(1)</i>.</p>	

**IX. ANCILLARY SERVICES** (Continued)

<p>The monthly charge for Message Processing, Message Bill Processing, Bill Rendering, Online Bill pay, Fundamental Billing and Inquiry Services, will be one-twelfth (1/12) of the appropriate yearly message capacity (i.e., MTS service billed or bulk-billed capacity estimate) furnished by the customer as set forth above, times the appropriate Message Processing, Message Bill Processing, Bill Rendering, Online Bill Pay, Fundamental Billing and Inquiry Services rate.</p>	
<p>e. Payment of Charges</p> <p>When the Company purchases Call Recording from another telephone company and/or Message Processing Services from another telephone company or entity for a customer, the rates and charges for such services contained in this tariff are applicable.</p>	
<p>f. Customer's End User Deposits</p> <p>When Bill Rendering, Online Bill Pay, Fundamental Billing Services are ordered, the Company will determine and collect a deposit from the customer's end user in accordance with the Company deposit regulations. The Company will provide the customer with a copy of its deposit regulations upon request.</p>	
<p><b>C. <u>Description of Ancillary Services</u></b></p> <p>Ancillary Services consist of a.) Billing and Collection Service and b.) Operator Services. Ancillary Services shall be furnished to subscribers to the Company's access services, and in addition other telecommunications service providers, including providers of telephone answering services or voice messaging services.</p>	
<p>All subscribers of Ancillary Services are subject to the terms and conditions contained within this tariff. Should the customer choose to perform his/her own ancillary functions and require sufficient information to do so, listed customer information may be purchased consistent with state regulations governing any rights to privacy. Charges for such lists will be calculated on an individual case basis.</p> <p>Billing and Collection Services:</p> <p>1. <i>Call Recording Service</i></p> <p>The Company will provide Call Recording in Company suitably equipped end offices or tandems. Call Recording is available only with FGC, FGD or similar Feature Group offerings when used in the provision of MTS/WATS services. Call Recording is the entering on magnetic tape or other acceptable media the details of customer messages originated through Switched Access Service or Switched Access-like Service for which answer and disconnect supervision has been received. The Company will provide the customer, upon request, the recorded message detail, as agreed to by both parties, for each completed intrastate message generated by end users gaining access to the customer from the Access Area.</p>	
<p>The equipment at the customer designated location shall provide such signals as may be required for the proper operation of the Company's automatic call recording equipment used to perform this function.</p>	

**IX. ANCILLARY SERVICES** (Continued)

<p>The Company may purchase Call Recording Service from another telephone company. Another telephone company or entity may purchase Call Recording Service from the Company.</p>	
<p>A standard format for the provision of the recorded message detail will be established by the Company. The Company will provide to the customer the precise details of the format. If, in the course of Company business, it is necessary to change the format, the Company will provide notification to the customer six (6) months in advance of the change.</p>	
<p><b>2. Message Processing Service</b></p> <p>Message Processing Service consists of the transformation of recorded customer message details into rated messages. Message Processing Service will be provided for each intrastate message generated by end users gaining access to the customer from the Access Area of the Company. Message Processing Service includes the following:</p> <p>a. Assembly of Message Detail</p> <p>This function consists of arranging the customer's recorded message details into a format required for subsequent processing.</p>	
<p>b. Editing of Message Detail</p> <p>This function consists of examining individual message details and identifying the messages with errors or the messages which require further examination.</p>	
<p>c. Rating of Messages</p> <p>This function consists of calculating the charges for messages based on the customer's schedule of charges and the message detail.</p>	
<p>The Company will provide Message Processing Service only for customer messages originated within the Access Area.</p>	
<p>For the purpose of performing Message Processing Service, the Company may purchase Message Processing Service from another telephone company or entity as set forth in IX.B.3.e.. Another telephone company or entity may purchase Message Processing Service from the Company.</p>	
<p>Where the customer provides its own message details, it must be in the standard format established by the Company. The Company will provide to the customer the precise details of the required format. If, in the course of Company business, it is necessary to change the format, the Company will provide notification to the customer six (6) months in advance of the change.</p>	
<p>Where the Company has rated customer messages which are to be billed to an end user by another telephone company or entity, the Company will enter the customer messages on a magnetic tape or data file and transmit the rated messages as set forth in IX.C.1.d..</p>	

**IX. ANCILLARY SERVICES** (Continued)

<p><b>3. <i>Assembly and Editing Service</i></b></p> <p>Assembly is the aggregation of recorded message details to create individual messages for rating. Editing is the process of verifying that the assembled message data is in accordance with the Company standard format and prescribed Exchange Message Interface (EMI) specifications.</p>	
<p>The editing function consists of examining individual message details and identifying the messages with errors or the messages requiring further examination. The editing process includes the validations of data categories such as; but not limited to, the following:</p> <ul style="list-style-type: none"> <li>- Called Telephone Number</li> <li>- Calling Telephone Number</li> <li>- Date</li> </ul>	
<p>The assembled and edited recorded message detail will be provided to the customer as set forth in <i>IX.C.1.d.</i>.</p>	
<p><b>4. <i>Call Record Provision Service</i></b></p> <p>Call Record Provision Service is the transmission and receipt of rated and unrated message data. It also includes the transmission of end user data as a result of customer generated activity (i.e., transmitting end user data during conversion activities, etc.).</p>	
<p>The billing information and/or end user data may be transmitted or received on magnetic tape or other acceptable media via either of two (2) principal methods:</p> <ul style="list-style-type: none"> <li>- Hand carried recording media (i.e., magnetic tape).</li> <li>- Direct interface (data link) to the Company billing center.</li> </ul>	
<p>The Company will determine the number of magnetic tapes required to transmit message/record data to the customer, another telephone company or billing entity.</p>	
<p><b>5. <i>Message Bill Processing Service</i></b></p> <p>Message Bill Processing Service is the accumulation, guiding and preparation of messages (including the application of taxes) for end user bill rendering for MTS/WATS services.</p>	
<p>Message-Billed Message Bill Processing Service is the accumulation, guiding, posting and formatting of rated message detail for bill rendering. The Company will process Calling Plans (i.e., Directory Assistance, Optional Calling Plans, Dial-It calls, etc.) that require the application of a discount to aggregate MTS usage as a part of its Message-Billed Message Bill Processing Service.</p>	
<p>Bulk-Billed Message Bill Processing Service is the accumulation, guiding and posting of rated message detail where the individual message detail is not provided on the bill rendered to the end user.</p>	

**IX. ANCILLARY SERVICES** (Continued)

<p>The rating may have been done by the Company, another entity or the customer. Where a customer subscribes to Message Processing Service, as set forth in <i>IX.C.1.b.</i>, the rated customer messages will be used as the input. If the customer provides the rated messages, the end user account to be billed shall be identified and the records shall be provided in the standard format established by the Company and delivered, as set forth in <i>IX.C.1.d.</i> or <i>IX.D.1.m.</i>, to the location specified by the Company.</p>	
<p>If the customer provided rated messages must be converted by the Company to the standard format, and the Company agrees to make the conversion, program development charges as set forth in the Company Price List for Ancillary Services apply for the hours required to design, develop, test and maintain the necessary programs. If, in the course of Company business, it is necessary to change the format, the Company will provide notification to the customer six (6) months in advance of the change.</p>	
<p>The Company will only provide Message Bill Processing Service when Bill Rendering Service and Record Keeping are ordered.</p>	
<p>The Message Bill Processing Service rate band will be determined by the Company based on the customer's total number of interstate and intrastate messages per year.</p>	
<p><b>6. Bill Rendering Service</b></p> <p>Bill Rendering Service is the printing and mailing of statements showing amounts due from end users for services provided by the customer. Bill Rendering Service includes payment and remittance processing, treatment, denial of service and collection of deposits (where appropriate) and other monies due from the end user. Bill Rendering Service is provided on a per bill basis.</p>	
<p>When the Company provides Bill Rendering Service, the customer's statement of the amount due may, at Company option, be included as part of the regular monthly bill for local exchange service mailed to the end user.</p>	
<p>The Company may, in accordance with its deposit regulations, determine and collect a deposit from the end user for the customer's services as set forth in <i>IX.B.3.f.</i> When necessary, the Company, in accordance with its treatment procedures, shall deny the customer's services and/or local exchange services to an end user. Where local exchange service access is denied, access to the customer's services will also be denied.</p>	
<p>Bill Rendering Service will only be provided in conjunction with the purchase of a customer's receivables. The Company will not be responsible for any customer's balance due from end users prior to the initial order period.</p>	
<p>The Company will only provide Bill Rendering Service when Message Bill Processing Service with Record Keeping is ordered or when Fundamental Billing service is ordered.</p>	
<p>The Bill Rendering Service rate band will be determined by the Company based on the customer's total number of bills per year.</p>	

**IX. ANCILLARY SERVICES** (Continued)

<p><b>7. Message Investigation Service</b></p> <p>The Company will provide Message Investigation Service when requested by the customer. Message Investigation Service is that activity undertaken by the Company to secure, or attempt to secure proper billing information in an effort to sustain or recharge the customer's message. The Company will investigate, at the request of the customer, unbillable messages to correct message detail information to allow for the proper billing application.</p>	
<p>The customer's request for Message Investigation Service shall identify the customer message, the date the customer message was billed and the amount of the customer message. Message Investigation Service is provided on a per message investigated basis.</p>	
<p>Message Investigation Service will be provided for each intrastate message generated by end users gaining access to the customer MTS/WATS services from the Access Area of the Company.</p>	
<p><b>8. Online Bill Pay</b></p> <p>Online Bill Pay Service includes the preparation of bills, mailing of the bills to the end users and the collection of deposits and monies due from the end users. Online Bill Pay also includes master file maintenance.</p>	
<p>Online Bill Pay Service is provided on a per message billed basis (message-billed) or on a bulk-billed basis when necessary. The Company will process Calling Plan (i.e., Directory Assistance, Optional Calling Plans, Dial-It calls, etc.) that require the application of a discount to aggregate MTS usage as a part of its message-billed billing.</p>	
<p>When Online Bill Pay Service is ordered, the Company will accumulate, guide and post rated messages in preparation for billing (includes the application of taxes). The Company will also print and mail statements showing amounts due from end users for MTS services provided by the customer.</p>	
<p>Online Bill Pay Service provided to the customer will include receiving payments from the customer's end users, treatment of receivables, treatment of accounts, master file maintenance and collection of deposits (where appropriate) as set forth in IX.B.3.f.. When necessary, the Company, in accordance with its treatment procedures, shall deny the customer's services and/or local exchange services to an end user. Where local exchange service access is denied, access to the customer's services will also be denied.</p>	
<p>The rating may have been done by the Company, another entity or the customer. Where the customer subscribes to Message Processing Service as set forth in IX.C.1.b., the rated customer messages will be used as the input. If the customer or another entity provides the rated messages, the end user account to be billed shall be identified and the records shall be provided in the standard format established by the Company and delivered as set forth in IX.C.1.d. or IX.D.1.m..</p>	
<p>Online Bill Pay will only be provided in conjunction with the purchase of a customer's receivables. The Company will not be responsible for any customer's balance due from end users prior to the initial order period.</p>	

**IX. ANCILLARY SERVICES** (Continued)

<p><b>9. Fundamental Billing</b></p> <p>Fundamental Billing is the centralized receipt of Fundamental Billing records for inclusion on the end user bill.</p>	
<p>Fundamental Billing includes the preparation of bills, mailing of statements of the amount due for services provided by the customer and the collection of deposits (where appropriate) and monies due from the customer's end users. Fundamental Billing also includes account establishment, maintenance of accounts and treatment of accounts.</p>	
<p>When the Company provides Fundamental Billing, the customer shall rate its end users messages, calculate the taxes and the total amount (surcharges, discounts, allowances, recurring fees, etc.) to be billed for services it provided to its end users, prior to sending the Fundamental Billing records to the Company.</p>	
<p>The customer's statement of the amount due may, at Company option, be included as part of the regular monthly bill for local exchange service mailed to the end user.</p>	
<p>As a part of its treatment procedures, the Company shall have the final authority to make adjustments or deny service for disputed charges on the end user's account.</p>	
<p>Fundamental Billing will only be provided in conjunction with the purchase of a customer's receivables. The Company will not be responsible for any customer's balance due from end users prior to the initial order period.</p>	
<p>Call Record Provision charges, as set forth in the Company Price List for Ancillary Services, shall apply for the receipt of accepted messages and the return of rejected messages. Bill Rendering charges, as set forth in <i>II.A.5.a.</i>, shall apply for each bill rendered. In addition, the Fundamental Billing charges as set forth in the Company Price List for Ancillary Services shall apply.</p>	
<p><b>10. Program Development Service</b></p> <p>Program Development Service consists of developing the customer's schedule of rates into a rating program and changing the bill format when requested by the customer. Program Development Service also includes converting message data, transmitted to the Company by the customer or another entity, into the Company standard format for processing.</p>	
<p>A Program Development Charge, as set forth in the Company Price List for Ancillary Services, applies for the programming hours required for software designing and coding.</p>	
<p>A Program Implementation Charge applies for table updating, testing, administration, documenting program changes and other implementation activities.</p>	
<p>Changes in the rate levels of customer charges to be billed will normally be implemented within thirty (30) days after receipt of an order from the customer requesting such change. When modification to the rating program is required, a Program Development Charge will also apply. Changes in rate structure will normally be completed within six (6) months of a customer's order.</p>	



**IX. ANCILLARY SERVICES** (Continued)

<p>The complexity of the structural change will determine the exact length of time necessary to fulfill the request. Rate structure changes will be made only when the Company can accommodate such changes.</p>	
<p><b>11. Inquiry Service</b></p> <p>Inquiry Service consists of answering end user questions about charges billed for the customer's services, applying credits and adjustments to end user accounts, and reviewing messages removed from end user bills.</p>	
<p>When the Company provides Inquiry Service, the Company will be responsible for contacts and arrangements (either written or oral) with the customer's end users concerning the billing, collecting, crediting, adjusting and message investigation of the customer's service charges in accordance with written instructions furnished by the customer and agreed to by the Company. Billed messages removed from an end user's bill will be appropriately adjusted to the customer's accounts receivable as agreed to by both parties.</p>	
<p>The Company will not become involved in disputes between a customer and its end users. Consequently, utilizing Company guidelines previously established for the collection process for its own accounts, the Company may remove a disputed customer's charge from an end user's bill and deduct that amount from the customer's accounts receivable. It will be the customer's responsibility to pursue the collection of the disputed amount.</p>	
<p>The Company shall have the final authority to make adjustments or deny service for disputed charges on end users accounts.</p>	
<p>Inquiry Service will only be provided in conjunction with the purchase of a customer's receivables. The Company will not be responsible for any customer's balances due from end users prior to the initial order period.</p>	
<p>Inquiry Service will only be provided when Message Bill Processing, Online Bill Pay or Fundamental Billing is ordered. Inquiry Service will only be provided in the Company's operating territory.</p>	
<p>Inquiry Service consists of a bifurcated rate structure, a per message billed rate and a per adjustment rate.</p>	
<p><b>D. Rate Regulations</b></p> <p><b>1. Billing and Collection Services</b></p> <p>a. Call Recording Service for MTS/WATS services includes the functions listed in IX.C.1.a.. The rate, as set forth in the Company Price List for Ancillary Services, applies per message recorded.</p>	

**IX. ANCILLARY SERVICES** (Continued)

<p>b. Message Processing Service for MTS/WATS services includes the functions listed in IX.C.1.b.. The rate, as specified in the Company Price List for Ancillary Services, applies per message processed. In those locations where WATS services are metered, or the billing record is summarized by another telephone company, the Message Processing rate, as set forth in the Company Price List for Ancillary Services, will apply per billing record processed. For rating purposes, a billing record is defined as any record which is required to be processed to accomplish billing of a customer's WATS usage.</p>	
<p>c. Assembly and Editing Service for MTS/WATS services consists of the functions listed in IX.C.1.c.. The rate, as specified in the Company Price List for Ancillary Services, applies per message assembled and edited.</p>	
<p>d. When message detail is transmitted to or received from the customer, another telephone company or billing entity, a Call Record Provision charge will apply. For this purpose, a record is a logical grouping of information as described in the program that processes the information and loads the magnetic tape or data file. The rate, as specified in the Company Price List for Ancillary Services, applies per record transmitted or received. The Company will determine the Call Record Provision charge based on its count of the records transmitted or received.</p>	
<p>e. The Message Bill Processing Service charge applies whenever the Company performs the functions listed in IX.C.1.e.. The rate for Message Bill Processing Service shall be the rate corresponding to the Message Bill Processing Service rate for such volume of messages, both intrastate and interstate, as set forth in the Company Price List for Ancillary Services on a calendar year basis. As used in the tariff, the term calendar year shall mean the period from January 1 through December 31 (both dates inclusive) of a given year. The Message Bill Processing Service rate band will be determined by the Company based on the customer's total number of interstate and intrastate messages per year.</p>	
<p>The Company will use the customer provided message capacity to determine the band and its associated rate the first year of the initial minimum period. During the first quarter of the next year, the customer and the Company will determine the actual volume of messages for which the Company performed Message Bill Processing Service. Such actual volumes shall be compared to the Message Bill Processing Service bands as set forth in the Company Price List for Ancillary Services to determine which band such actual volume of messages fall. If the actual volume is greater than or less than customer provided message capacity, the actual volume will be multiplied by the appropriate band rate and compared to the billed volume to determine either a charge or credit. This charge or credit will be applied to the customer's subsequent bill.</p>	
<p>For each year thereafter, the Company and the customer shall utilize the previous year's actual volume of messages and the customer provided message capacity in an effort to determine the appropriate band for the next calendar year. In the first quarter of each year, the procedure described in the previous paragraph will be followed.</p>	
<p>The rate, as specified in the Company Price List for Ancillary Services, applies per message processed. The bulk-billed Message Bill Processing Service charge applies per WATS/800/888 message processed.</p>	

**IX. ANCILLARY SERVICES** (Continued)

<p>f. Bill Rendering Service includes the functions listed in <i>IX.C.1.f.</i>. The rate for Bill Rendering shall be the rate corresponding to the Bill Rendering Service rate for such volume of bills for a particular Company billing service, both intrastate and interstate, as found in the Company Price List for Ancillary Services on a calendar year basis. As used in this tariff, the term calendar year shall mean the period from January 1, through December 31 (both dates inclusive) of a given year. The Bill Rendering Service rate band is determined by the Company based on the customer's total number of bills per year.</p>	
<p>The Company will use the customer provided bill capacity to determine the band and its associated rate the first year of the initial minimum period. During the first quarter of the next year, the customer and the Company will determine the actual volume of bills for which the Company performed Bill Rendering Service. Such actual volumes shall be compared to the Bill Rendering Service bands as set forth in the Company Price List for Ancillary Services to determine which band such actual volume of bills fall. If the actual volume is greater than or less than the customer provided bill capacity, the actual volume will be multiplied by the appropriate band rate and compared to the billed volume to determine either a charge or credit. This charge or credit will be applied to the customer's subsequent bill.</p>	
<p>For each year thereafter, the Company and the customer shall utilize the previous year's actual volume of bills and the customer provided bill capacity in an effort to determine the appropriate band for the next calendar year. In the first quarter of each year, the procedures described in the previous paragraph will be followed.</p>	
<p>The rate, as specified in the Company Price List for Ancillary Services, applies per bill rendered. A factor, based on actual interstate and intrastate billed-messages, will be used by the Company to apportion the Bill Rendering charge by jurisdiction.</p>	
<p>g. Message Investigation Service consists of the functions listed in <i>IX.C.1.g.</i>. The rate, as specified in the Company Price List for Ancillary Services, applies per message investigated by the Company.</p>	
<p>h. Online Bill Pay Service consists of the functions listed in <i>IX.C.1.h.</i>. The rate, as set forth in the Company Price List for Ancillary Services, applies per message.</p>	
<p>i. Fundamental Billing consists of the functions listed in <i>IX.C.1.i.</i>. The rate, as set forth in the Company Price List for Ancillary Services, applies per message per bill.</p>	
<p>j. A Record Keeping charge applies for each end user account maintained by the Company for the customer. An end user account is a record which has a name and address and a unique billing identification number assigned by the Company to which a bill is rendered. The Record Keeping charge, as specified in the Company Price List for Ancillary Services, applies per month for each account and/or line maintained. A factor, based on actual interstate and intrastate billed messages, will be used to apportion the Record Keeping charge by jurisdiction.</p>	
<p>k. An Exchange Carrier Memorandum (EC Memo) charge will be assessed each time the customer requests a manual adjustment to an end user account. The EC Memo charge, as specified in the Company Price List for Ancillary Services, applies per account adjusted per memo. When necessary, a factor (based on actual interstate and intrastate adjusted messages) will be used to apportion the EC Memo charge by jurisdiction.</p>	

**IX. ANCILLARY SERVICES** (Continued)

<p>l. A Service Order Change Charge applies whenever a billing service order is accepted by the Company to update (i.e., add, change or delete) its billing file to implement the requested activity. The Service Order Change Charge, as set forth in the Company Price List for Ancillary Services, applies per order processed.</p>	
<p>m. A Centralized Message Dispersion charge will apply when the Company provides a single point for the receipt of customer message data. The Company will receive, edit, sort, disperse and confirm the number of accepted billable messages and the total amount due the customer for services provided to its end users. In addition, the rated and/or unrated message data is dispersed to the appropriate location for further processing and/or billing. The rates, as set forth in the Company Price List for Ancillary Services will apply per message processed. Call Record Provision charges, as set forth in the Company Price List for Ancillary Services will apply for the receipt of each billable message and the transmission of each unbillable message. This charge does not apply to Fundamental Billing Service.</p>	
<p>n. Inquiry Service includes the functions listed in IX.C.1.k.. Inquiry Service consists of a bifurcated rate structure, a per message billed and a per adjustment rate. The Inquiry Service per message billed rate applies for each customer message billed by the Company. The per message adjustment rate applies for each occurrence of an adjustment made to an end user bill.</p>	
<p>A PIU factor will be used by the Company to apportion the message adjustment rate by jurisdiction.</p>	
<p><b>2. Operator Services</b></p> <p>a. Operator Services described in this Section will be provided to access customers as an optional feature with FGC, FGD, BSA-C or BSA-D Switched Access Services from designated Operator Services Switching locations in those LATAs where the Company has the capability to provide such services. Operator Services includes Operator Transfer functions which enables a customer to provide operator related services to their end users.</p>	
<p>b. General Description</p> <p>Operator Transfer Service:</p> <p>Operator Transfer Service is an originating service that provides call transfer of 0- (the digit 0 with no additional digits) interLATA calls to a participating customer as requested by the calling end user. Operator Transfer Service is provided when an end user dials "0" and is routed to the Company's operator and requests completion of an interLATA call. Operator Transfer Service provides for the routing of the call from the Company's Operator Services Switching Location to one customer designated location in the same LATA.</p>	
<p>The Company operator will ask the end user to identify the customer to which they desire to be connected. The operator will then transfer the call to the designated customer.</p>	

**IX. ANCILLARY SERVICES** (Continued)

<p>If the end user has no preference, or the identified customer has not subscribed to Operator Transfer Service, the end user will be asked to select from a list of participating customers. The list of participating Operator Transfer Service customers will be updated monthly. The order in which participating customers will appear on the list will be initially determined by use of a random drawing. For each subsequent monthly update following the initial selection, the customer in the first position will be moved to the last position on the list. All other customers will be moved up one position. New Operator Transfer Service customers will be placed at the bottom of the list of participating customers pending the next monthly update.</p>	
<p>c. Service Provisioning</p> <p>(1) The Company will provide Operator Transfer Service for calls originating from all end offices within the LATA served by a designated Operator Services Switching Location.</p>	
<p>A list of end offices served by the Operator Services Switching Location will be provided to the customer upon request.</p>	
<p>(2) Operator Services will be provided over FGC, FGD, BSA-C or BSA-D trunk groups, arranged for either one-way or two-way calling, from the Operator Services Switching Location to one (1) customer designated location in the same LATA.</p>	
<p>(3) Switched Access used in conjunction with Operator Services will be provisioned in accordance with the technical specifications and requirements set forth in Section V. of this tariff.</p>	
<p>(4) Designated Company Operator Services Switching Locations are identified in ZiPLY Fiber FCC Tariff No. 2. The designated locations will be in those LATAs in which the Company is able to provide Operator Services.</p>	
<p>d. Rate Regulations</p> <p>Where the Company has measurement capability for Operator Services per call charges, the Company will bill the actual usage measured on a per call basis. For Operator Transfer Service, FGC, FGD, BSA-C and BSA-D access minutes will also be billed in addition to the per call charge.</p>	
<p>When measurement capability is not available, the customer shall furnish a forecast of the number of calls (call capacity) anticipated for each month of the succeeding year by type of call (i.e., Operator Transfer) and by Operator Services Switching Location at the time the order is placed. For mixed intrastate and interstate services, the customer's estimate shall include the percent of interstate calls. At a minimum, the customer shall revise this forecast annually. More frequent revisions of the forecast may be submitted, however, no more than once per month.</p>	

**IX. ANCILLARY SERVICES** (Continued)

<p>Such estimates shall be used as a basis for billing the Operator Services per call charges until such time as the Company has actual measurement capability available. The customer shall maintain records supporting such estimates.</p> <p>Operator Transfer Service:</p> <p>(1) Operator Transfer Service Rate</p> <p>The Operator Transfer Service Rate is assessed per 0- call transferred to a customer. A 0-call is considered transferred when the Company Operator activates the transfer function sending the call to the designated customer.</p>	
<p>(2) Switched Access Charges</p> <p>FGC, FGD, BSA-C or BSA-D Switched Access usage charges and Carrier Common Line Charges will also apply per minute of use for Operator Transfer Service.</p>	
<p><b>E. <u>Rates and Charges</u></b></p> <p>1. <i>Billing and Collection Service</i></p> <p>Ancillary Rates and Charges for Billing and Collection Service can be found on the Company Price List.</p>	
<p>2. <i>Operator Services</i></p> <p>Operator Transfer Service Per Call Transferred</p>	<p style="text-align: right;"><u>Charge</u></p> <p style="text-align: right;">\$.35</p>

## X. SPECIAL FACILITIES ROUTING OF FIA

<p><b>A. <u>Description of Special Facilities Routing of FIA</u></b></p> <p>The FIA provided under this tariff are provided over such routes and facilities as the Company may elect. Special routing is involved where, in order to comply with requirements specified by the customer, the Company provides Switched Access or Special Access Services, in a manner which includes one or more of the following conditions.</p> <p>1. <i>Diversity</i></p> <p style="padding-left: 40px;">Where two or more FIA must be provided over not more than two (2) different physical routes. Diversity is a Basic Service Element (BSE) under the Company's Open Network Architecture (ONA) Plan.</p>	
<p>2. <i>Avoidance</i></p> <p style="padding-left: 40px;">Where a FIA must be provided on a route which avoids specified geographical locations.</p>	
<p>3. <i>Cable-Only Facilities</i></p> <p style="padding-left: 40px;">Where certain voice grade FIA are provided on cable-only facilities to meet the particular needs of a customer or end user. FIA is provided subject to the availability of cable-only facilities. In the event of FIA failure, restoration will be made through the use of any available facilities as selected by the Company.</p>	
<p>Avoidance and Diversity are available for Switched Access as described in V., or Special Access as in VI.. Cable-only facilities are available for Switched Access as in V., Voiceband Special Access as in VI.B.1..</p>	
<p>In order to identify any special routing requirement, the Company will provide the ordering customer with the required routing information for each specially routed FIA. If requested by the customer, this information will be provided when the FIA is installed and prior to any subsequent change in routing.</p>	
<p>The rates and charges for Special Facilities Routing of FIA as set forth in X.B. following are in addition to all other rates and charges that may be applicable for FIA provided under other sections of this tariff.</p>	
<p><b>B. <u>Rates and Charges</u></b></p> <p>The rates and charges for Special Facilities Routing of FIA are as follows:</p> <p>1. <i>Diversity</i></p> <p style="padding-left: 40px;">For each FIA provided in accordance with X.A.1. preceding, the rates and charges will be developed on an Individual Case Basis and filed following:</p> <p style="padding-left: 40px;">(Reserved for Future Use)</p>	

**X. SPECIAL FACILITIES ROUTING OF FIA** (Continued)

<p>2. <i>Avoidance</i></p> <p>For each FIA provided in accordance with X.A.2. preceding, the rates and charges will be developed on an Individual Case Basis and filed following:</p> <p>(Reserved for Future Use)</p>	
<p>3. <i>Diversity and Avoidance Combined</i></p> <p>For each FIA provided in accordance with X.A.1. and X.A.2. preceding, combined, the rates and charges will be developed on an Individual Case Basis and filed following:</p> <p>(Reserved for Future Use)</p>	
<p>4. <i>Cable-Only Facilities</i></p> <p>For each FIA provided in accordance with X.A.3. preceding, the rates and charges will be developed on an Individual Case Basis and filed following:</p> <p>(Reserved for Future Use)</p>	



## XI. SPECIAL CONSTRUCTION

<p><b>A. <u>General</u></b></p>	<p>This section contains the regulations applicable for Special Construction of Company facilities which are used to provide FIA offered under this tariff.</p>
	<p>When Special Construction of FIA is required, the provisions of this section apply in addition to regulations, rates and charges set forth in other sections of this tariff.</p> <p><b>1. <i>Conditions Requiring Special Construction</i></b></p> <p>Special Construction is required when facilities are not available to meet a customer's ASR and one or more of the following conditions exist:</p> <ul style="list-style-type: none"> <li>- The Company has no other requirement for the facilities constructed at the customer's request;</li> <li>- The customer requests that FIA be furnished using a type of facility, or via a route, other than that which the Company would otherwise utilize in furnishing the requested FIA;</li> <li>- The customer requests the construction of more facilities than is required to satisfy its ASR;</li> <li>- The customer requests construction be expedited resulting in added cost to the Company;</li> <li>- The customer requests that temporary facilities be constructed until permanent facilities are available.</li> <li>- The customer requests construction of permanent facilities to be used for temporary Video broadcast service.</li> </ul>
	<p><b>2. <i>Filing of Charges</i></b></p> <p>Charges and liabilities for Special Construction will be filed in <i>XI.B.</i></p>
	<p>When Special Construction is required under conditions that preclude the filing of charges in full accordance with the Commission's Rules and Regulations (e.g., unavailability of cost details, short notice service date):</p> <p>a. After charges have been filed and have become effective they will apply from the date that the Special Construction was provided.</p>
	<p>b. Charges and/or Maximum Termination Liabilities for Special Construction of facilities provided by a Connecting Carrier are developed by the Connecting Carrier and are filed by the Company in this tariff on its behalf.</p>
	<p>c. Regulations and charges for Special Construction of facilities provided by Other Participating Carriers are filed in their tariffs.</p>
	<p><b>3. <i>Ownership of Facilities</i></b></p> <p>The Company retains ownership of all specially constructed facilities, except for those facilities constructed by connecting companies or carriers, even though the customer may be required to pay Special Construction charges.</p>

## XI. SPECIAL CONSTRUCTION (Continued)

<p>4. <i>Interval to Provide FIA</i></p> <p>Based on available information and the type of FIA ordered, the Company will establish a scheduled date for the installation of necessary facilities. The date will be established on an Individual Case Basis and provided to the customer. The Company will make every reasonable effort to assure that the date is met. However, circumstances beyond the Company's control (e.g., backorder of components) may force a reschedule, and a new completion date will be established with the customer when appropriate.</p>	
<p>5. <i>Special Construction Involving Interstate and Intrastate FIA</i></p> <p>When Special Construction involves facilities used to provide both interstate and intrastate FIA, charges for the portion of the construction used to provide intrastate FIA shall be in accordance with this tariff. Charges for the portion of the construction used to provide interstate FIA shall be in accordance with the appropriate Company tariff providing Facilities for Interstate Access.</p>	
<p>B. <u>Liabilities, Charges and Payments</u></p> <p>1. <i>General</i></p> <p>This section describes the various charges and liabilities that apply when the Company provides Special Construction of FIA, as outlined in XI.B. preceding, in accordance with a customer's specific request. Once the customer is notified of all charges and liabilities, the customer must provide the Company with written approval prior to the start of construction. If more than one condition requiring Special Construction is involved, charges for each condition apply (see Conditions Requiring Special Construction, XI.A.1. preceding).</p>	
<p>2. <i>Payment of Charges</i></p> <p>Payment is due upon presentation of a bill for the specially constructed facilities.</p>	
<p>3. <i>State/End of Billing</i></p> <p>Billing of recurring charges for specially constructed FIA starts on the day after the FIA are provided. Billing accrues through and includes the day that the specially constructed FIA are discontinued. Monthly charges will be billed one month in advance.</p>	
<p>4. <i>Partial Payments</i></p> <p>The Company will require a customer which has a proven history of late payments to the Company, or does not have established credit, to make a partial payment for the portion of the estimated cost of the Special Construction for which the customer is subject to a nonrecurring charge. Partial payments will be requested as costs are incurred and will be credited to the customer's account. Partial payments will not exceed the total nonrecurring charge to the customer for the Special Construction.</p>	

**XI. SPECIAL CONSTRUCTION** (Continued)

<p><b>5. Development of Liabilities and Charges</b></p> <p>The customer has the option of accepting the liabilities and charges based on estimated or actual costs. Estimated costs will be used unless the customer notifies the Company of the selection of the actual cost option in writing prior to the start of Special Construction.</p>	
<p>Under the estimated cost option, Special Construction liabilities and charges are developed based on estimated costs and will be filed in this tariff.</p>	
<p>Under the actual cost option, if all actual costs are not available prior to the in-service date of the FIA, estimated Special Construction charges will be filed in this tariff. As soon as the actual costs, including cost of maintaining and filing these costs, are subsequently determined, the estimated charges will be adjusted to reflect the actual costs. The filed charges will then reflect actual costs existing at the time the FIA are provided.</p>	
<p><b>6. Types of Contingent Liabilities</b></p> <p>Depending on the specifics associated with each individual case the following Maximum Termination Liability may be applicable for Special Construction.</p> <p>a. Maximum Termination Liability</p> <p>A MTL has two (2) components, an amount and a specified period of time.</p>	
<p>The amount is equal to all non-recoverable costs less the net salvage value (e.g., depreciation, return, income tax associated with the specially constructed facilities). The amount will be amortized over the average account life of the specially constructed facilities. The standard liability period is the average account life of the Specially Constructed facilities expressed in years.</p>	
<p>At the customer's option, an optional liability period shorter than the average account life may be established. If the customer chooses an optional liability period, the MTL amortization schedule will not change. The remaining MTL amount for the period between the expiration of the optional liability period and the expiration of the amortization schedule will be due as a lump sum payment (LS) at the time the optional liability period expires unless the case of Special Construction is extended.</p>	
<p>Prior to the expiration of an optional liability period, the customer has the option to a.) extend the use of the specially constructed FIA establishing a new liability period, or b.) terminate the case of Special Construction and pay the lump sum payment.</p>	
<p>The Company will notify the customer six months in advance of the expiration date of the optional liability period. The customer must provide the Company with written notification of its intentions to be received one month prior to expiration of the optional liability period. Failure to do so, and payment of the next month's charges, will result in extension of the case of the Special Construction and the establishment of a new liability period equal to the remaining amortization period. A Case Preparation Charge will always apply if the Special Construction case is extended.</p>	
<p>The MTL and the liability period applicable to specific cases of Special Construction will be filed in Section XI.D., XI.E. and XI.F..</p>	

**XI. SPECIAL CONSTRUCTION** (Continued)

<p>b. Reduction on Maximum Termination Liability</p> <p>The time frames for MTL for Special Construction are expressed by an effective date and an expiration date. The MTL will be reduced for each month the Special Construction FIA is in service. For example, if the MTL period is ten (10) years, for each month in service the MTL would be reduced 1/120th.</p>	
<p>7. <i>Types of Charges</i></p> <p>Two (2) categories of charges may be applicable for Special Construction. These charges are nonrecurring charges and recurring charges. These categories are described below.</p> <p>a. Nonrecurring Charges</p> <p>One or more of the following nonrecurring charges may apply for each case of Special Construction: case preparation, termination, cancellation, expediting the construction, or optional payment charges.</p> <p>(1) Case Preparation Charge</p> <p>The charge for case preparation includes the administrative expense associated with preparing and listing charges in the tariff. This expense includes such items as: 1.) tariff preparation and processing and 2.) gross receipts and surcharge taxes.</p>	
<p>(2) Termination Charge</p> <p>A Termination Charge applies when, at the customer's request, FIA provided on specially constructed facilities which have a Maximum Termination Liability are discontinued prior to the expiration of the liability period.</p>	
<p>The charge reflects the unamortized portion of the nonrecoverable cost at the time of termination of the specially constructed FIA adjusted for tax effects, for net salvage and for possible reuse. Administrative costs associated with the specific case of Special Construction and any cost for restoring a location to its original condition are also included. Termination Charges will never exceed the MTL.</p>	
<p>(3) Cancellation Charge</p> <p>If the customer cancels an ASR with which Special Construction is associated prior to the in-service date of the FIA, a Cancellation Charge will apply. The charge will include all nonrecoverable costs less the net salvage value incurred by the Company up to and including the time of cancellation.</p>	
<p>(4) Expediting Charge</p> <p>An Expediting Charge applies when a customer requests that Special Construction be completed on an expedited basis. The charge is equal to the difference in the estimated cost of construction on an expedited basis and construction without expediting.</p>	

**XI. SPECIAL CONSTRUCTION** (Continued)

<p>(5) Optional Payment Charge</p> <p>The customer may elect to pay an Optional Payment Charge when it requests Special Construction of facilities utilizing 1.) a type of facilities or 2.) a route other than that which the Company would otherwise utilize in furnishing the requested service. Payment of this charge will result in a lower recurring charge for the Special Construction. This election must be made in writing, before Special Construction starts.</p>																											
<p>If this election is coupled with the actual cost option, the Optional Payment Charge will reflect the actual cost of the specially constructed facilities.</p> <p>(a) Development of Optional Payment Charge</p> <p>This charge is equal to the excess installed cost or the total nonrecoverable cost, whichever is less (based on estimated or actual costs as elected by the customer).</p> <p>Example 1:</p> <table data-bbox="451 829 1218 1228"> <tr> <td>Total Installed Cost</td> <td>\$30,000</td> </tr> <tr> <td>Nonrecoverable Cost</td> <td>20,000</td> </tr> <tr> <td>Normal Installed Cost</td> <td>17,000</td> </tr> <tr> <td> </td> <td></td> </tr> <tr> <td>Total Installed Cost</td> <td>30,000</td> </tr> <tr> <td>Minus Normal Installed Cost</td> <td>17,000</td> </tr> <tr> <td>Equals Excess Installed Cost</td> <td>13,000</td> </tr> <tr> <td>Optional Payment Charge</td> <td>13,000</td> </tr> <tr> <td> </td> <td></td> </tr> <tr> <td>Nonrecoverable Cost</td> <td>20,000</td> </tr> <tr> <td>Minus Optional Payment Charge</td> <td>13,000</td> </tr> <tr> <td>Equals Investment for MTL Computation</td> <td>7,000</td> </tr> <tr> <td>Remaining Recoverable Excess Installed Cost</td> <td>0</td> </tr> </table>	Total Installed Cost	\$30,000	Nonrecoverable Cost	20,000	Normal Installed Cost	17,000	 		Total Installed Cost	30,000	Minus Normal Installed Cost	17,000	Equals Excess Installed Cost	13,000	Optional Payment Charge	13,000	 		Nonrecoverable Cost	20,000	Minus Optional Payment Charge	13,000	Equals Investment for MTL Computation	7,000	Remaining Recoverable Excess Installed Cost	0	
Total Installed Cost	\$30,000																										
Nonrecoverable Cost	20,000																										
Normal Installed Cost	17,000																										
Total Installed Cost	30,000																										
Minus Normal Installed Cost	17,000																										
Equals Excess Installed Cost	13,000																										
Optional Payment Charge	13,000																										
Nonrecoverable Cost	20,000																										
Minus Optional Payment Charge	13,000																										
Equals Investment for MTL Computation	7,000																										
Remaining Recoverable Excess Installed Cost	0																										

**XI. SPECIAL CONSTRUCTION** (Continued)

Since the total installed cost is \$30,000 and the normal installed cost would have been \$17,000, the nonrecurring charge (optional payment) is limited to the difference (i.e., \$13,000). A Maximum Termination Liability would then be established to protect the remaining nonrecoverable cost of \$7,000 which is the difference between the total nonrecoverable cost (\$20,000) and the nonrecurring charge (\$13,000). The remaining excess installed cost in this example is zero. In addition, a recurring charge will be developed as set forth in *XI.B.7.b.* following.

Example 2:

Total Installed Cost	\$30,000
Nonrecoverable Cost	10,000
Normal Installed Cost	17,000
Total Installed Cost	30,000
Minus Normal Installed Cost	17,000
Equals Excess Installed Cost	13,000
Optional Payment Charge	10,000
Nonrecoverable Cost	10,000
Minus Optional Payment Charge	10,000
Equals Investment for MTL Computation	0
Remaining Recoverable Excess Installed Cost	3,000

The Optional Payment Charge is limited to the nonrecoverable cost. In this example the Optional Payment Charge equals the nonrecoverable cost. Therefore, there is no Maximum Termination Liability. In addition, a recurring charge will be developed as set forth in *XI.B.7.b.* following.

**XI. SPECIAL CONSTRUCTION** (Continued)

(b) Replacement Charge

If any portion of the specially constructed FIA, for which an Optional Payment Charge has been paid, requires replacement involving capital investment, a charge for replacement will apply. This charge will be in the same ratio as the initial Optional Payment Charge was to the installed cost of the specially constructed FIA. The customer will be notified in writing that the replacement is required. Replacement will not be made without the customer's ASR. If any portion of the FIA subject to the replacement charge fails, the FIA will not be restored until the customer orders the replacement.

Example:

Original Total Installed Cost	\$30,000
Original Optional Payment Charge	15,000
Subsequent Cost of Replacement	2,000

$$\frac{\text{Original Optional Payment Charge} \times \text{Replacement Cost}}{\text{Total Installed Cost}}$$

$$\frac{15,000 \times 2,000}{30,000} = 1,000$$

Replacement Charge	1,000
--------------------	-------

**XI. SPECIAL CONSTRUCTION** (Continued)

b. Recurring Charges

These charges apply on a monthly or annual basis for specially constructed FIA. There are three (3) conditions for which recurring charges apply:

- When a customer requests the construction of more facilities than are necessary to provide the FIA currently ordered.
- When a customer requests a facility route or type other than that which the Company would utilize to provide FIA.
- When a customer's request results in the Company leasing transmission or other equipment from private vendors to provide a FIA (Lease Charge).

(1) Excess Capacity Charge

An Excess Capacity Charge applies when the customer requests more facilities be constructed than are required to satisfy the customer's ASR. The charge is based on the estimated cost difference between the facilities constructed at the customer's request and the facilities actually required to meet the customer's ASR.

Example:

A customer has an immediate FIA requirement which would require a 100 pair cable but requests the installation of a 300 pair cable to allow for growth.

Total Installed Cost (300 Pair)	\$2,500
Estimated Annual Cost	920
Estimated Installed Cost (100 Pair)	1,000
Estimated Annual Cost	368

Excess Recurring Charge:      Annually  $920 - 368 = 552$

Monthly  $552/12 = 46$

This charge applies until such time as the customer orders sufficient FIA to necessitate use of a larger size cable (e.g., 200 pair cable). At that time the recurring charge is adjusted as indicated in the following example:

Total Installed Cost (300 Pair)	\$2,500
Estimated Annual Cost	920
Estimated Installed Cost (100 Pair)	1,900
Estimated Annual Cost	683

Excess Recurring Charge:      Annually  $920 - 683 = 237$

Monthly  $237/12 = 19.75$



### XI. SPECIAL CONSTRUCTION (Continued)

<p>The charge is revised in this manner until the number of FIA being provided would require a three hundred (300) pair cable, at which time the Excess Capacity Charge is no longer applied. The charge would be reapplied if the number of FIA declined to a level which would not require a three hundred (300) pair cable.</p>	
<p>Such charges will continue to apply to all facilities held in abeyance until the period of termination liability expires. If facilities are still held in abeyance after the termination liability expires, a new schedule of rates will be calculated and such rates will apply as long as facilities are held in abeyance for the customer.</p>	
<p>(2) Charge for Route or Type Other Than Normal</p> <p>When the customer requests Special Construction using a route or type of FIA other than that which the Company would normally use, a recurring charge is applicable. The charge is the difference between the estimated recurring costs of the specially constructed FIA and the estimated recurring costs of the FIA the Company would normally use. The charge will be no greater than the recurring costs of the specially constructed FIA.</p> <p>(a) If the customer elects to pay an Optional Payment Charge, the portion of the recurring charge for the excess investment covered by the optional payment excludes capital cost items (depreciation, return on investment and Federal income tax on that return). The remaining recurring expense cost items associated with the optional payment (maintenance, administration, and other taxes) are increased by a ten percent (10%) management fee and will be included in the recurring charge.</p>	
<p>The portion of any recurring charge associated with any remaining Special Construction investment will include both capital and expense costs. The ten percent (10%) management fee is not applied to this portion of the recurring charge.</p>	

**XI. SPECIAL CONSTRUCTION** (Continued)

Development of Recurring Monthly Charge for Optional Payments:				
For example 1 see XI.B.7.a.(6)(a)				
	Special Route or Type of FIA			Normal
	A	B	C	D
	Optional Payment Nonrecurring Charge for Special <u>Const. FIA</u>	Specially Constructed FIA Less Nonrecurring <u>Charges</u>	Normal Existing <u>Facilities</u>	Route/Type <u>Facilities</u>
	\$13,000	\$17,000		\$17,000
1. Depreciation	---	1,122		408
2. Federal Income Tax and Return	---	2,142		2,346
3. Maintenance	1,131	1,479		799
4. Administrative	455	595		595
5. Other Taxes	286	37		374
6. Sub Total	1,872	---	---	---
7. 10% x Line 6	187	---	---	---
8. Totals	(A) \$2,059	(B) \$5,712	(C)	(D) \$4,522
	A + B = \$7,771			
	A + B + C = 7,771			
	(A + B + C) - D = 3,249			
	Excess Recurring Charge <sup>14</sup> : Annually \$ 3,249.00			
	Monthly \$ 270.75			

<sup>14</sup> The lowest of (A + B + C) - D, or (A + B)

**XI. SPECIAL CONSTRUCTION** (Continued)

For example 2 see XI.B.7.a.(5)(a)				
	Special Route or Type of FIA			Normal
	A	B	C	D
	Optional Payment Nonrecurring Charge for Special <u>Const. FIA</u>	Specially Constructed FIA Less Nonrecurring <u>Charges</u>	Normal Existing <u>Facilities</u>	Route/Type <u>Facilities</u>
	\$10,000	\$20,000		\$17,000
1. Depreciation	---	1,320		408
2. Federal Income Tax and Return	---	2,520		2,346
3. Maintenance	870	1,740		799
4. Administrative	350	700		595
5. Other Taxes	220	440		374
6. Sub Total	1,440	---	---	---
7. 10% x Line 6	144	---	---	---
8. Totals	(A) \$1,584	(B) \$6,720	(C)	(D) \$4,522
<p style="margin-left: 40px;">A + B = \$8,304  A + B + C = 8,304  (A + B + C) – D = 3,782</p> <p>Excess Recurring Charge<sup>15</sup>: Annually \$ 3,782.00  Monthly \$ 315.17</p>				
<p>(b) If the customer has elected the actual cost option, the recurring charge will be adjusted to reflect the actual cost of the new construction when the cost is determined. This adjusted recurring charge is applicable from the start of FIA.</p>				
<p>(3) Lease Charge</p> <p>A Lease Charge applies when the Company leases equipment (e.g., portable microwave equipment) in order to provide FIA to meet the customer's requirements. The amount of the charge is the net added cost to the Company caused by the lease.</p>				

<sup>15</sup> The lowest of (A + B + C) - D, or (A + B)

**XI. SPECIAL CONSTRUCTION** (Continued)

<p><b>8. Application of Charges</b></p> <p>The charges for Special Construction are those charges which are in effect for the period that the Special Construction is furnished. If the charges for a period covered by a bill change after the bill has been rendered, the bill will be adjusted to reflect the new charges. Charges are based on Special Construction of 1.) permanent FIA or 2.) temporary FIA.</p> <p>a. Special Construction of Permanent FIA</p> <p>(1) Special Construction When Not Available and There is No Other Requirement of Them</p> <p>When permanent FIA are not available and the Company constructs them and there is no other Company need for the specially constructed FIA, a nonrecurring charge, and a Maximum Termination Liability may be applicable.</p>	
<p>(2) Special Construction using a Route of Type of FIA Other Than Normal</p> <p>When the specially constructed FIA involve a route or type of FIA other than that which the Company would ordinarily use, charges are based on the difference between the estimated costs of the specially constructed FIA and those the Company would ordinarily use. A nonrecurring charge, a recurring charge, and a Maximum Termination Liability may be applicable.</p>	
<p>(3) Special Construction of a Greater Quantity of FIA Than Necessary Satisfy the Customer's Order for Service</p> <p>When the Company constructs more FIA than is required to satisfy the customer's ASR, additional charges will apply. These charges may include a nonrecurring charge, a recurring charge, and a Maximum Termination Liability.</p>	
<p>(4) Special Construction Expedited at Greater Cost Than Would Otherwise be Incurred</p> <p>When construction is expedited resulting in added costs, a nonrecurring Expediting Charge applies.</p>	
<p>b. Special Construction of Temporary FIA Order</p> <p>When permanent FIA are not available and temporary FIA are constructed pending the construction of permanent FIA, a nonrecurring charge, and a Maximum Termination Liability may be applicable.</p>	
<p><b>C. <u>Deferral of the In-Service of FIA</u></b></p> <p>1. <i>General</i></p> <p>The customer may request the Company to defer the in-service of FIA on specially constructed FIA subject to the provisions as set forth in <i>IV.B.2.a.</i>. If the deferral is not in compliance with the provisions as set forth in <i>IV.B.2.a.</i>, the Special Construction case is considered to be cancelled and cancellation charges apply. Requests for deferral must be in writing and are subject to the following regulations.</p>	

**XI. SPECIAL CONSTRUCTION** (Continued)

<p><b>2. Construction Has Not Started</b></p> <p>If the Company has not incurred any costs (e.g., engineering and/or installation) before receiving the customer's request for deferral, no charge applies other than the Case Preparation Charge. However, the original quotation is subject to Company review at the time of reinstatement to determine if the original charges are still valid. Any change in liabilities and charges requires the concurrence of the customer in writing. Additional Case Preparation Charges will also apply.</p>	
<p><b>3. Construction Has Started But is Not Complete</b></p> <p>If the construction of FIA has started, but has not been completed, before the Company receives the customer's request for deferral, charges apply. The charges vary depending on whether all or some of the FIA ordered are deferred.</p> <p>a. All FIA Are Deferred</p> <p>When all FIA involving Special Construction are deferred, a charge equal to the costs incurred during each month of the deferral applies. Those costs include the recurring costs for that portion of the FIA already completed and any other costs associated with the deferral. The Case Preparation Charge also applies.</p>	
<p>b. Some But Not All FIA Are Deferred</p> <p>When some, but not all, FIA utilizing the specially constructed FIA are deferred, the Special Construction case will be completed. Maximum Termination Liability will apply in addition to Case Preparation Charges and any recurring charges associated with the Special Construction.</p>	
<p><b>4. Construction Complete</b></p> <p>If the construction of FIA has been completed before the Company receives the customer's request for deferral, the Case Preparation Charge as originally determined, will apply and any recurring charges associated with the Special Construction. The Maximum Termination Liability Period will begin when the customer accepts the service.</p>	

**XII. (RESERVED FOR FUTURE USE)**

--	--

### XIII. CARRIER COMMON LINE ACCESS SERVICE

<p><b>A. <u>General Description</u></b></p> <p>Carrier Common Line charges are applicable with Switched Access under Section V. of this tariff.</p>	
<p><b>B. <u>Description of Carrier Common Line Service</u></b></p> <p>1. <i>Description</i></p> <p>Carrier Common Line charges compensate the Company for the use of Company provided common lines by customers for access to end users in furnishing intrastate communications.</p>	
<p>2. <i>Limitations</i></p> <p>a. Exclusions</p> <p>Neither telephone number nor detail billing are provided with Carrier Common Line access. Additionally, Directory listings and Intercept arrangements are not included in the rates and charges for Carrier Common Line access.</p>	
<p>b. WATS/WATS-type Access Lines</p> <p>Where Switched Access Services are connected with Special Access Services at Company designated WATS Serving Offices for the provision of WATS/WATS-type Services, Switched Access Service minutes which are carried on that end of the service (i.e., originating minutes for outward WATS/WATS-type services and terminating minutes for inward WATS/WATS-type services) shall not be assessed Carrier Common Line per minute charges with the following exception. Carrier Common Line per minute charges shall apply when FGA, FGB, BSA-A or BSA-B Switched Access is ordered from a non-equal access Company end office or access tandem that does not have measurement capabilities, (i.e., cannot create an Automatic Message Automatic record).</p>	
<p><b>C. <u>Obligations of the Customer</u></b></p> <p>1. <i>Switched Access Service Requirement</i></p> <p>Switched Access Service associated with the Carrier Common Line charges shall be ordered by the customer under other sections of this tariff.</p>	
<p>2. <i>Supervision</i></p> <p>The customer facilities at the premises of the ordering customer shall provide the necessary on-hook supervision.</p>	

**XIII. CARRIER COMMON LINE ACCESS SERVICE** (Continued)

<p><b>D. <u>Rate Regulations</u></b></p>	
<p>1. <i>Description and Application of Rates</i></p>	
<p>a. Billing of Charges</p>	<p>Carrier Common Line charges will be billed to each Switched Access Service provided under this tariff in accordance with the regulations as specified. in e., except as specified in d. and XIII.D.3.d..</p>
<p>b. Measuring and Recording of Call Detail</p>	<p>When access minutes are used to determine Carrier Common Line charges, they will be accumulated using call detail recorded by Company equipment except as described in c. and FGC or BSA-C operator and automated operator services systems call detail such as pay telephone sent-paid, operator-DDD, operator-person, collect, credit card, third number and/or other like calls recorded by the customer. The Company measuring and recording equipment, except as described in c., will be associated with end office or access tandem switching equipment and will record each originating and terminating access minute, as described in Section V., where answer supervision is received. The accumulated access minutes will be summed on a line by line or trunk by trunk basis, by access group or by end office, whichever type of account is used by the Company, for each customer and then rounded to the nearest minute.</p>
<p>c. Unmeasured FGA, FGB, BSA-A and BSA-B Usage</p>	<p>When Carrier Common Line charges are applicable in association with FGA, FGB, BSA-A or BSA-B Switched Access Service in Company offices that are not equipped for measurement capabilities, an assumed average intrastate access minutes will be used to determine Carrier Common Line charges. These assumed access minutes are in Section V..</p>
<p>d. Mixed Interstate Intrastate Usage</p>	<p>When the customer reports - interstate and intrastate use of Switched Access Service, Carrier Common Line charges, in XIII.E., will be billed only to intrastate Switched Access Service access minutes based on the data reported by the customer in Section V., except where the Company is billing according to actual usage by jurisdiction. Intrastate Switched Access Service access minutes will, after adjustments as described in XIII.D.3.d., when necessary, be used to determine Carrier Common Line charges as specified in e..</p>
<p>e. Determination of Premium and Nonpremium Charges</p>	<p>The application of premium and nonpremium rates for a specific customer, as described in Section V., is dependent upon the Switched Access feature group and the availability of equal access capabilities in the end office or the WATS Serving Office from which the service is provided.</p>



**XIII. CARRIER COMMON LINE ACCESS SERVICE** (Continued)

<p>After the adjustments in <i>d.</i> and <i>XIII.D.3.d.</i>, have been applied, when necessary, to Switched Access Service access minutes, charges for the involved customer account will be determined as follows:</p>	
<p>(1) Premium rated Switched Access Service minutes subject to Carrier Common Line charges will be multiplied by the premium access per minute rate in <i>XIII.E.</i>.</p>	
<p>(2) Nonpremium rated Switched Access Service minutes subject to Carrier Common Line charges will be multiplied by the nonpremium access per minutes rate in <i>XIII.E.</i>.</p>	
<p>(3) Carrier Common Line charges shall not be reduced, as described in <i>XIII.D.3.a.</i>, unless Switched Access charges in FCC Tariff No. 5, are applied to the customer's Switched Access Services.</p>	
<p>(4) The terminating Premium and/or Non-premium Access, per minute charge(s) apply to:</p>	
<ul style="list-style-type: none"> <li>- all terminating access minutes of use;</li> </ul>	
<ul style="list-style-type: none"> <li>- all originating access minutes of use associated with FGA or BSA-A Access Services where the off-hook supervisory signaling is forwarded by the customer's equipment when the called party answers;</li> </ul>	
<ul style="list-style-type: none"> <li>- all originating access minutes of use associated with calls placed to Service Access Code numbers, less those originating access minutes of use associated with calls placed to 500, 700, 800, 877, 888 and 900 numbers for which the customer furnishes a report of either the number of minutes or a report of the percent of minutes that terminate to a subscriber or common line, rather than a dedicated access line. This report will be provided by the customer on a quarterly basis, indicating for each month thereof or quarter, the information as described in order to calculate the common line charges.</li> </ul>	
<p>The customer will provide a report indicating separate common line information for 500, 700, 800, 877, 888 and 900 access minutes, at a statewide level. This report shall also include the applicable Access Customer Name Abbreviation [ACNA(s)].</p>	
<p>The report will be based on the calendar year and will be due by the 15th day of the month preceding the quarter for which it is to be applied in order to become effective with the first full month of usage. Should the report be received after the 15th day of the month, the Company will make every effort to process the report as described above. When received by the Company as described herein, the quarterly report will be used for calculating common line charges on a current bill basis for the next three (3) months usage.</p>	
<p>Prorating or backbilling will not occur based on the report. Any under or over estimation should be reflected in the subsequent quarterly report.</p>	
<p>If a billing dispute arises concerning the customer provided report, the Company will request the customer to provide the data used to develop the report. The Company will not request such data more than once a year. The customer shall supply the data within thirty (30) days of the Company's request.</p>	

**XIII. CARRIER COMMON LINE ACCESS SERVICE** (Continued)

<p>In the event the customer fails to provide a quarterly report, the Company will use the previously reported information to calculate the common line charge.</p>	
<p>(5) The originating Premium and/or Non-premium Access apply to:</p> <ul style="list-style-type: none"> <li>- all originating access minutes of use;</li> </ul>	
<ul style="list-style-type: none"> <li>- less those originating access minutes of use associated with FGA or BSA-A Access Services where the off-hook supervisory signalling is forwarded by the customer's equipment when the called party answers;</li> </ul>	
<ul style="list-style-type: none"> <li>- less all originating access minutes of use associated with calls placed to Service Access Code numbers;</li> </ul>	
<ul style="list-style-type: none"> <li>- plus all originating access minutes of use associated with calls placed to 500, 700, 800, 877, 888 and 900 numbers for which the customer furnishes a report of either the number of minutes or a report of the percent of minutes that terminate to a subscriber or common line, and for which a corresponding reduction in the number of terminating access minutes of use has been made as described in (4).</li> </ul>	
<p>f. Determination of Oregon Customer Access Fund Rate</p> <p>The Oregon Customer Access Fund rate is applied by the Company to all terminating rated CCLC access minutes billed to the customer in addition to other rates in XIII.E..</p>	
<p>2. <i>Determination of Usage Subject to Carrier Common Line Charges</i></p> <p>Except as set forth herein, all Switched Access Service provided to the customer will be subject to Carrier Common Line charges.</p> <p>a. Determination of Jurisdiction</p> <p>When the customer reports interstate and intrastate use of Switched Access Service, the associated Carrier Common Line charges for intrastate usage will be determined as described in Section V..</p>	
<p>b. Cases Involving Usage Recording by the Customer</p> <p>Where FGC or BSA-C end office switching is provided without Company recording and the customer records minutes of use to determine Carrier Common Line charges (i.e., FGC operator and calls such as pay telephone sent-paid, operator-DDD, operator-person, collect, credit card, third number and/or other like class), the customer shall furnish such minutes of use detail to the Company in a timely manner. If the customer does not furnish the data, the customer shall identify all Switched Access Services which could carry such calls in order for the Company to accumulate the minutes of use through the use of special Company measuring and recording equipment.</p>	

### XIII. CARRIER COMMON LINE ACCESS SERVICE (Continued)

<p>3. <i>Resold Services</i></p> <p>a. <i>Scope</i></p> <p>Where the customer is reselling MTS/MTS-type service(s) on which the Carrier Common Line and Switched Access charges have been assessed, the customer may, at the option of the customer, obtain FGA, FGB, FGD, BSA-A, BSA-B, or BSA-D Switched Access Service under this tariff in Section V., for originating and/or terminating access in the local exchange. Such access group arrangements, whether single lines or trunks or multiline hunt groups or trunk groups, will have Carrier Common Line charges in <i>XIII.E.</i> applied in accordance with the resale rate regulations specified in <i>d.</i> For purposes of administering this provision:</p> <p style="padding-left: 40px;">Resold intrastate terminating MTS/MTS-type service(s) shall include collect calls, third number calls and credit card calls where the reseller pays the underlying carrier's service charges, and shall not include interstate minutes of use.</p> <p style="padding-left: 40px;">Resold intrastate originating MTS/MTS-type service(s) shall not include collect, third number, credit card or interstate minutes of use</p>	
<p>b. <i>Customer Obligations Concerning the Resale of MTS/WATS-type Services</i></p> <p>When the customer is reselling MTS/MTS-type service, as described in <i>a.</i>, the customer will be charged Carrier Common Line charges in accordance with the resale rate regulations, as described in <i>d.</i>, if the customer or the provider of the MTS/MTS-type service furnishes documentation of the MTS/MTS-type services. Such documentation shall be supplied each month by the customer and shall identify the involved resold MTS/MTS-type services.</p>	
<p>The monthly period used to determine the minutes of use for resold MTS/MTS-type service(s) shall be the most recent monthly period for which the customer has received a bill for such resold service(s). This information shall be delivered to the Company, at a location specified by the Company, no later than fifteen (15) days after the bill date shown on the resold MTS/MTS-type service bill. If the required information is not received by the Company, the previously reported information, will be used for the next two (2) months. For any subsequent month, no allocation or credit will be made until the required documentation has been received by the Company.</p>	
<p>c. <i>Resale Documentation Provided by the Customer</i></p> <p>When the customer utilizes Switched Access Service, as described in <i>b.</i>, the Company may request a certified copy of the customer's resold MTS/MTS-type usage billing from either the customer or the provider of the MTS/MTS-type service. Requests for billing will go back no more than twelve (12) months prior to the current billing period.</p>	

### XIII. CARRIER COMMON LINE ACCESS SERVICE (Continued)

d. Rate Regulations Concerning the Resale of MTS/WATS-type Services

When the customer is provided an access group or BSA to be used with the resale of MTS/MTS-type services, as described in *a.*, subject to the limitations, as described in *XIII.B.2.*, and the billing entity receives the usage information required, as described in *b.*, to calculate the adjustment of Carrier Common Line charges, the customer will be billed, as specified in (4), (5) or (6), depending upon, whether the usage is from non-equal access offices, equal access offices or a combination of the two.

(1) Apportionment and Adjustment of Resold Minutes of Use

When the customer is provided with more than one access group or BSA in a LATA in association with the resale of MTS/MTS-type services, the resold minutes of use will be apportioned as follows:

(a) Originating Services

The Company will apportion the resold originating MTS/MTS-type services and originating minutes of use for which the resale credit adjustment applies, among the access groups and BSAs. Such apportionment will be based on the relationship of the originating usage for each access group or BSA to the total originating usage for all access groups or BSAs in the LATA. For purposes of administering this provision:

Resold originating MTS/MTS-type services minutes shall be only those attributable to intrastate originating MTS/MTS-type minutes and shall not include collect, third number, credit card or interstate minutes of use.

The resale credit adjustment shall apply for resold originating MTS/MTS-type services and minutes of use, provided Carrier Common Line and Switched Access charges have been assessed on such services.

(b) Terminating Services

The Company will apportion the resold terminating MTS/MTS-type services and terminating minutes of use for which the resale credit adjustment applies, among the access groups and BSAs. Such apportionment will be based on the relationship of the terminating usage for each access group or BSA to the total terminating usage for all access groups or BSAs in the LATA. For purposes of administering this provision:

Resold terminating MTS/MTS-type services minutes shall be only those attributable to intrastate terminating MTS/MTS-type minutes of use (i.e., collect, third number, and credit card) and shall not include interstate minutes of use or MTS/MTS-type minutes of use paid for by another party.

The resale credit adjustment shall apply for resold terminating MTS/MTS-type services and minutes of use, provided Carrier Common Line and Switched Access charges have been assessed on such services.

**XIII. CARRIER COMMON LINE ACCESS SERVICE** (Continued)

<p>(2) Same State/Telephone Company/Exchange Limitation</p> <p>In order for the rate regulations to apply, as specified in (4), (5), (6), the access groups or BSAs and the resold MTS/MTS-type services must be provided in the same state (except when the same extended area service arrangement is provided in two (2) different states by the same telephone company) in the same exchange, provided by the same telephone company and connected directly or indirectly. For those exchanges that encompass more than one state, the customer shall report the information by state within the exchange.</p>	
<p>(3) Direct and Indirect Connections</p> <p>Each of the access group or BSA arrangements used by the customer in association with the resold MTS/MTS-type services must be connected either directly or indirectly to the customer designated premises at which the resold MTS/MTS-type services are terminated. Direct connections are those arrangements where the access groups and resold MTS/MTS-type services are terminated at the same customer designated premises.</p>	
<p>Indirect originating connections are those arrangements where the access groups, BSAs and the resold originating MTS/MTS-type services are physically located at different customer designated premises in the same exchange. Such different customer designated premises are connected by facilities that permits a call to flow from access groups and BSA's to resold MTS/MTS - type services.</p>	
<p>Indirect terminating connections are those arrangements where the access groups, BSAs and resold terminating MTS/MTS-type services are physically located at different customer designated premises in the same exchange. Such different customer designated premises are connected by facilities that permits a call to flow from resold terminating MTS/MTS-type services to access groups or BSAs.</p>	
<p>(4) Access Groups and BSAs – Nonequal Access Offices Only</p> <p>The adjustments, as described here and in (5) and (6), will be computed separately for each access group and for each BSA.</p>	
<p>When all the usage on an access group or BSA originates from and/or terminates to end offices that have not been converted to equal access, the nonpremium charge per minute, as described in XIII.E., will apply. The access minutes which will be subject to Carrier Common Line charges will be the adjusted originating intrastate access minutes for such access groups or BSAs.</p>	
<p>The adjusted originating access minutes will be the originating intrastate access minutes less the reported resold originating MTS/MTS-type service minutes of use in (1)(a), but not less than zero (0). The adjusted terminating access minutes will be the terminating intrastate access minutes less the reported resold terminating MTS/MTS-type service minutes of use in (1)(b), but not less than zero (0).</p>	

**XIII. CARRIER COMMON LINE ACCESS SERVICE (Continued)**

<p>(5) Access Groups and BSAs – Equal Access Offices Only</p> <p>When all the usage on an access group or BSA originates from and/or terminates to end offices that have been converted to equal access, the premium charges per minutes in <i>XIII.E.</i>, will apply. The minutes billed Carrier Common Line charges will be the adjusted originating intrastate access minutes and the adjusted terminating intrastate access minutes for such access groups or BSAs.</p>	
<p>The adjusted originating access minutes will be the originating intrastate access minutes less the reported resold originating MTS/MTS-type service minutes of use in (1)(a), but not less than zero (0). The adjusted terminating access minutes will be the terminating intrastate access minutes less the reported resold terminating MTS/MTS-type service minutes of use in (1)(b), but not less than zero (0).</p>	
<p>(6) Access Groups and BSAs – Nonequal Access and Equal Access Offices</p> <p>When an access group or BSA has usage that originates from and/or terminates to both end offices that have been converted to equal access and end offices that have not been converted, both premium and nonpremium per minute charges in <i>XIII.E.</i> will apply respectively. The minutes billed Carrier Common Line charges will be the adjusted originating intrastate access minutes plus the adjusted terminating intrastate access minutes for such access groups or BSAs.</p>	
<p>The adjusted originating access minutes will be the originating intrastate access minutes less the reported resold originating MTS/MTS-type service minutes of use in (1)(a), but not less than zero (0). The adjusted terminating access minutes will be the terminating intrastate access minutes less the reported resold terminating MTS/MTS-type service minutes of use in (1)(b), but not less than zero (0).</p>	
<p>The adjusted originating access minutes and the adjusted terminating access minutes will be apportioned between premium and nonpremium access minutes using end-office specific usage data when available, or when usage data are not available, usage ratios, as described in Section V. will be utilized. The premium and nonpremium per minute charges in <i>XIII.E.</i> will apply to the respective premium and nonpremium access minutes determined in this manner.</p>	
<p>(7) When the Adjustment Will Be Applied to Customer Bills</p> <p>The adjustment, as described in (4), (5) and (6), will be made to the involved customer account no later than either the next bill date, or the one subsequent to that, depending on when the usage report is obtained.</p>	
<p>(8) Conversion of Billed Usage to Minutes</p> <p>When the MTS/MTS-type usage is shown in hours, the number of hours shall be multiplied by sixty (60) to develop the associated MTS/MTS-type minutes of use. If the MTS/MTS-type usage is shown in a unit that does not show hours or minutes, the customer shall provide a factor to convert the shown units to minutes.</p>	

**XIII. CARRIER COMMON LINE ACCESS SERVICE** (Continued)

<p>(9) Mixed Interstate and Intrastate Usage</p> <p>The adjustment, as described in (4), (5) and (6) will be made to the involved customer account after making the adjustments to the customer account, as described in Section V..</p>	
<p>4. <i>Transitional Billing Arrangements</i></p> <p>Transitional billing arrangements apply when FGA or FGB Switched Access Service is provided to a first point of switching (i.e., dial tone office for FGA and an access tandem for FGB) which has usage originating from and/or terminating at both end offices that have been converted to equal access and end offices that have not been converted. Premium and nonpremium rates for the Carrier Common Line Charge will apply in the following manner:</p> <p>a. All access minutes that originate from or terminate at an equal access end office(s) will be billed premium rates with an exception as set forth in following. Access minutes that originate from or terminate at end offices not equipped with equal access capabilities are billed at nonpremium rates.</p>	
<p>b. The number of access minutes that originate or terminate at each end office is determined as follows:</p> <p>(1) Where measurement capability exists, and end office specific usage data is available, the measured access minutes are used.</p>	
<p>(2) Where measurement capability does not exist and/or end office specific usage data is not available, originating and/or terminating usage will be apportioned between premium and nonpremium end offices as follows. The usage to be apportioned will be the recorded usage or the assumed usage as specified in Section V.. Such apportionment will be based on a ratio of the number of subscriber lines in each end office in the Access Area to the total number of subscriber lines in that Access Area. The ratio thus developed is applied to the total measured or assumed originating FGA usage, terminating FGA usage, originating FGB usage or terminating FGB usage, as applicable, to apportion usage among all end offices in the Access Area.</p>	
<p>The ratios used to apportion FGA and FGB minutes will be updated on a quarterly basis dependent upon the availability of line data from other telephone companies. The ratios to be used for the succeeding quarter will be provided to the customer with the last bill rendered in the quarter or mailed separately within five (5) working days after the first day of the new quarter (i.e., January, April, July and October). For purposes of administering this provision: 1.) subscriber lines are defined as exchange service lines, Centrex lines and Centrex-type lines provided by the Company under its Local Tariff and 2.) the Access Area is defined as the local calling area of the end office switch from which the FGA is provided for originating and terminating FGA, and for all end offices subtending a customer selected access tandem for originating and terminating FGB.</p>	
<p>c. Where FGD Switched Access Service is subscribed to by a customer in an end office(s) where FGA or FGB access minutes have been allocated in accordance with b.(2) preceding, such access minutes will be adjusted in the following manner.</p>	

**XIII. CARRIER COMMON LINE ACCESS SERVICE (Continued)**

<p>For each FGD access minute originating from or terminating at that end office, one originating or terminating FGA or FGB premium access minute allocated, as set forth in (2) preceding, will be reduced to nonpremium. In no event shall the reduction exceed the total number of FGA or FGB access minutes originating from or terminating at that end office.</p>																					
<p>When FGA or FGB originating or terminating minutes are greater than the FGD originating or terminating minutes, the difference (the greater amount) is identified as premium FGA or FGB minutes in the equal access end office, the residual amount (i.e., the remaining minutes) in that end office is considered as nonpremium usage and billed at nonpremium rates.</p>																					
<p>d. Specific details and methodology used to apportion FGA or FGB minutes as described in the preceding paragraphs will be provided to the customer upon request within fifteen (15) days of the receipt of such request.</p>																					
<p><b>E. <u>Rates and Charges</u></b></p> <p>The rates for Carrier Common Line Access Service are:</p> <table style="width: 100%; border-collapse: collapse;"> <thead> <tr> <th style="width: 80%;"></th> <th style="text-align: right; vertical-align: bottom;"><u>Rate per Access Minute</u></th> </tr> </thead> <tbody> <tr> <td>Premium, per minute</td> <td></td> </tr> <tr> <td>- Terminating</td> <td style="text-align: right;">---</td> </tr> <tr> <td>- Originating 8YY</td> <td style="text-align: right;">---</td> </tr> <tr> <td>- Originating Non-8YY</td> <td style="text-align: right;">---</td> </tr> <tr> <td>-</td> <td></td> </tr> <tr> <td>Nonpremium, per minute</td> <td></td> </tr> <tr> <td>- Terminating</td> <td style="text-align: right;">---</td> </tr> <tr> <td>- Originating 8YY</td> <td style="text-align: right;">---</td> </tr> <tr> <td>- Originating Non-8YY</td> <td style="text-align: right;">---</td> </tr> </tbody> </table> <p>The rate of Oregon Customer Access Fund is:</p> <p>Oregon Customer Access Fund per terminating minute<sup>16</sup></p>			<u>Rate per Access Minute</u>	Premium, per minute		- Terminating	---	- Originating 8YY	---	- Originating Non-8YY	---	-		Nonpremium, per minute		- Terminating	---	- Originating 8YY	---	- Originating Non-8YY	---
	<u>Rate per Access Minute</u>																				
Premium, per minute																					
- Terminating	---																				
- Originating 8YY	---																				
- Originating Non-8YY	---																				
-																					
Nonpremium, per minute																					
- Terminating	---																				
- Originating 8YY	---																				
- Originating Non-8YY	---																				

---

<sup>16</sup> The Company concurs in the OCAF rate as stated in P.U.C. OR. No. 1 of the Oregon Exchange Carrier Association (OECA).



**XIV. (RESERVED FOR FUTURE USE)**

--	--

## XV. EXCEPTIONS TO FIA OFFERINGS

The FIA/Services offered under the provisions of this tariff are subject to availability as set forth in *III.A.4.* and *III.A.2.a.(1)* preceding. In addition, the following exceptions apply.

- The following FIA/Services are not offered in the operating territory of the Company:

(Reserved for Future Use)

**XVI. (RESERVED FOR FUTURE USE)**

--	--

## XVII. COIN SERVICES

<p><b>A. <u>General</u></b></p>	<p>This section contains the rules and regulations pertaining to the provision of 1+ Coin Presubscription Service for the handling of 1+ interLATA sent-paid traffic from the Company's pay telephones.</p>
<p><b>B. <u>Service Description</u></b></p>	<p>1+ Coin Presubscription Service provides the routing of 1+ interLATA sent-paid calls from Company pay telephones to the presubscribed 0+ Interexchange Carrier (customer) directly, to its designated secondary service provider, or to the default carrier, provided said carrier continues to accept such default traffic. The default carrier option will expire when the default carrier ceases to accept such traffic or when the presubscribed 0+ provider can handle such calls or route them to secondary service providers, whichever comes first. The customer has the following options:</p> <ol style="list-style-type: none"> <li>1. to receive both 0+ and 1+ interLATA calls originated from Company pay telephones; or,</li> </ol>
	<ol style="list-style-type: none"> <li>2. to receive the 0+ interLATA calls and select one secondary service provider per LATA to receive the 1+ interLATA sent-paid traffic; or,</li> </ol>
	<ol style="list-style-type: none"> <li>3. to receive the 0+ interLATA calls and continue to default the 1+ interLATA sent-paid calls until the presubscribed 0+ provider is ready to handle (to receive both 0+ and 1+ interLATA calls or to receive 0+ interLATA calls and select a secondary service provider per LATA for 1+ interLATA calls) such calls.</li> </ol>
	<p>The customer is solely responsible for all 0+ and 1+ interLATA sent-paid calls originating from the Company pay telephone when it handles 1+ interLATA sent-paid traffic or selects a secondary service provider to handle the 1+ interLATA sent-paid calls.</p>
	<p>The Company must receive written authorization from the customer prior to routing 1+ interLATA sent-paid calls to the selected secondary service provider. If the customer selects a secondary service provider to handle 1+ interLATA sent-paid traffic, any arrangements will be solely between the customer and its selected secondary service provider.</p>
<p><b>C. <u>Service Provisioning</u></b></p>	<p>The Company will provide 1+ interLATA sent-paid access from equal access end offices to the customer's designated location via direct routed trunks from the end office or via its access tandem. The Company will designate an alternate access tandem for purposes of routing 1+ interLATA sent-paid traffic to the CDL, for end offices served by a 4ESS access tandem.</p>
	<p>The Company will provide, where available, either of two types of call setup signaling from its pay telephones, Tandem Access InterLATA Sent-Paid (TAISP) and Exchange Access Operator Services System (EAOSS) signaling from the access tandem to the CDL. If the equal access end office is equipped with either TAISP or EAOSS functionality, TAISP or EAOSS signaling can be provided via direct trunking from the end office or via the access tandem to the CDL at the customer's option. If the equal access end office is equipped with only Modified Operator Service Signaling (MOSS) functionality, only MOSS will be provided for direct trunking from the end office to the CDL.</p>

## XVII. COIN SERVICES (Continued)

<p>Coin control signaling will be either Expanded In-band or Multi-wink as determined by the Company. In some areas, both types are present and for these locations it will be necessary for the customer to utilize separate trunk groups for the two types.</p>	
<p><b>D. <u>Collection and Remittance of Coin Station Monies</u></b></p> <p>When the customer is provided Operator Assistance-Coin or Combined Coin and Noncoin or Operator Assistance-Full Feature Arrangements for sent-paid pay telephone access as set forth in FCC Tariff No. 5., the Company will collect sent-paid monies from pay telephone stations and will remit monies to the customer as set forth in <i>XVII.F.4.</i> Upon request from the customer, the Company will provide message call detail format and bill periods used to determine the monies.</p>	
<p><b>E. <u>Provision of Message Call Detail Concerning Coin Station Monies</u></b></p> <p>Where Operator Assistance-Coin or Combined Coin and Noncoin or Operator Assistance-Full Feature Arrangements for sent-paid pay telephone access is provided to the customer and the customer wishes to receive the monies it is due for the monies collected by the Company from coin pay telephone stations, the customer shall furnish to the Company, at a location specified by the Company, the customer message call detail for the customer sent-paid (coin) pay telephone calls according to the Company collection schedule. The customer message call detail furnished shall be in a standard format established by the Company. The Company will provide the precise details of the required standard format to the customer. If, in the course of Company business, it is necessary to change the standard format, the Company will provide notification to the involved customer six (6) months prior to the change.</p>	
<p>If no customer message call detail is received from the customer for each bill period established by the Company, the Company will assume there were no customer sent-paid (coin) pay telephone calls for the period. In addition the customer shall furnish a schedule of its charges for sent-paid (coin) calls to the Company at a location and date as specified by the Company. A change in the customer's schedule of charges shall be furnished to the Company one (1) day after the charges become effective.</p>	
<p><b>F. <u>Payment of Coin Sent-Paid Monies</u></b></p> <p>The Company will collect the monies from coin pay telephone stations and determine the amounts due to the customer for sent-paid pay telephone access as follows:</p> <ol style="list-style-type: none"><li><b>1. <i>Bill Period Coin Revenue</i></b></li></ol> <p>The Company will establish a collection schedule for each coin pay telephone station and will collect the monies from the coin pay stations based on this collection schedule. The monies collected based on this schedule during each bill period established by the Company will be identified by coin pay telephone station and summed to develop the Bill Period Coin Revenue for each coin record day (i.e., the day a record is prepared and dated to show the amount due the customer).</p>	

**XVII. COIN SERVICES** (Continued)

<p><b>2. Total Customer Coin Revenue</b></p> <p>The intrastate Total Customer Coin Revenue will be determined by the Company based on the customer message call detail received from the customer for each bill period and the customer's schedule of charges for sent-paid coin calls. Such Total Customer Coin Revenue will be developed each coin record day.</p>	
<p><b>3. Recourse Adjustments</b></p> <p>For each coin record day, the Company will subtract from the Total Customer Coin Revenue an amount for coin station shortages. Coin station shortages are amounts resulting from unauthorized calling at coin pay telephone stations, use of unauthorized coins (i.e., foreign coins, slugs and improper use of U. S. pennies), unauthorized removal of coins from coin pay telephone stations and coin refunds beyond the Company's control. Such amount will be rounded to the nearest penny. The shortage factor will be determined by dividing the yearly total coin shortage amount by the yearly total coin revenue amount (i.e., total coin revenue equals the coin revenue due under exchange tariffs, state toll tariffs and interstate toll tariffs). The total coin shortage amount and the total revenue amount will be determined by the Company through an annual special study.</p>	
<p><b>4. Payment of Net Customer Coin Revenue</b></p> <p>The Company will determine the Net Customer Coin Revenue for each coin record day by subtracting from the Total Customer Coin Revenue, determined as set forth in <i>XVII.F.2.</i>, the amount for coin station shortages, determined as set forth in <i>XVII.F.3.</i>. On the payment date, which is determined by adding forty-five (45) days to the coin record date, the Company will remit payment to the customer for the Net Customer Coin Revenue.</p>	
<p><b>5. Audit Provisions</b></p> <p>Upon reasonable written notice by the customer to the Company, the customer shall have the right through its authorized representative to examine and audit, all such records and accounts as recognized under accounting practices as containing information bearing upon the determination of the amount payable to the customer. This examination shall occur during normal business hours and at reasonable intervals as determined by the Company. Adjustments shall be made by the proper party to compensate for any errors or omissions disclosed by such examination or audit. Neither the right to examine and audit nor the right to receive such adjustment shall be affected by any statement to the contrary, appearing on checks or otherwise, unless such statement expressly waiving such right appears in a letter signed by the authorized representative of the party having such right and delivered to the other party.</p>	
<p>All information received or reviewed by the customer or its authorized representative is to be considered confidential and is not to be distributed, provided or disclosed in any form to anyone not involved in the audit, nor is such information to be used for any other purpose.</p>	

## XVIII. ADVANCED COMMUNICATIONS NETWORKS

<p><b>A. <u>General</u></b></p> <p>This section contains the rules and regulations pertaining to the provision of Packet Switching Network Service<sup>17</sup>, Frame Relay Service and Switched Ethernet Service.</p>							
<p>The regulations and rates specified herein are in addition to the applicable regulations and rates specified in other sections of this tariff.</p>							
<p>The following is a list of the Company's Open Network Architecture (ONA) Packet Service Basic Service Elements (BSEs) which provides a cross-reference to the generic ONA product names.</p> <table style="width: 100%; border: none;"> <thead> <tr> <th style="text-align: left; border-bottom: 1px solid black;"><u>Generic Name</u></th> <th style="text-align: left; border-bottom: 1px solid black;"><u>Name</u></th> </tr> </thead> <tbody> <tr> <td>Fast Select Acceptance – Packet</td> <td>Fast Select</td> </tr> <tr> <td>Fast Select Request – Packet</td> <td>Fast Select</td> </tr> </tbody> </table>	<u>Generic Name</u>	<u>Name</u>	Fast Select Acceptance – Packet	Fast Select	Fast Select Request – Packet	Fast Select	
<u>Generic Name</u>	<u>Name</u>						
Fast Select Acceptance – Packet	Fast Select						
Fast Select Request – Packet	Fast Select						
<p><b>B. <u>Packet Switching Network Service</u></b><sup>17</sup></p> <p><b>1. <i>Service Description</i></b></p> <p>Packet Switching Network Service uses packet switching technology to provide a switched data transport service. This service uses analog and digital facilities to provide data transport for a variety of interactive (or bursty) data applications between two (2) or more customer designated locations (CDLs). The packet switch will be classified as a CDL.</p>							
<p>Packet switching technology divides data streams into packets. The packet network examines, routes and transports packets individually without maintaining a physical path between bursts of data. This service is based on CCITT (International Telegraph and Telephone Consultative Committee) X.25 protocol and X.75 internetworking protocol. The X.25 and X.75 protocols are international standards developed by the CCITT that provide the foundation for Public Packet Switched Networks. Packet Switching Network Service and features are available where facilities and conditions permit.</p>							
<p><b>2. <i>Service Provisioning</i></b></p> <p>Customers may access the Packet Switching Network through an X.75 internetworking access.</p>							
<p>Packet switching carriers with a Data Network Identification Code may interconnect to an access port on the Packet Switching Network with X.75 protocol at transmission speeds of 9.6 Kbps or 56 Kbps. Each X.75 access will require an X.75 Access Port charge, a DDS Special Access Line charge (9.6 Kbps or 56 Kbps), associated DDS Special Transport charges, and Special Access Ordering charges set forth in Section VI..</p>							

---

<sup>17</sup> Effective May 13, 2003, Packet Switching Network Service as provided in Section XVIII.B. is no longer available to new customers. Moves, changes or additions will not be permitted to existing customers.

**XVIII. ADVANCED COMMUNICATIONS NETWORKS** (Continued)

<p>The Special Access Line and Special Transport charges provide analog or digital connections from the packet carrier's location to the access port on the Company's packet network. Shared use (ratcheting) to provision the access connection is not permitted.</p>										
<p>The special access service associated with packet switching will be subject to the meet point billing requirements set forth in Section III.. However, all packet usage recorded at the Company's packet switch will be billed by the Company.</p>										
<p>3. <i>Rate Regulations</i></p> <p>a. Minimum Period</p> <p>The minimum service period is one (1) month.</p>										
<p>b. Rate Application</p> <p>(1) Usage will be based on the access port speed and number of Logical Channels.</p>										
<p>(2) Rates for usage of the packet network will apply in addition to the monthly recurring charges for X.75 access. Rates applicable for X.75 access include a monthly recurring rate and installation charge per X.75 access port, and are specified in XVIII.B.4.a.. A DDS Special Access Line charge (9.6 Kbps or 56 Kbps), associated DDS Special Transport and Special Access Ordering charges from Section VI. will also apply.</p>										
<p>c. Usage Plans</p> <p>The customer must select one of the following flat rate usage options.</p> <p>9.6 Kbps Port with 12 Logical Channels            9.6 Kbps Port with 22 Logical Channels            9.6 Kbps Port with 32 Logical Channels            56 Kbps Port with 32 Logical Channels            56 Kbps Port with 60 Logical Channels            56 Kbps Port with 90 Logical Channels</p>										
<p>4. <i>Rates and Charges</i></p> <p>a. X.75 Access, Per Port</p> <table border="0" data-bbox="470 1470 1364 1680"> <thead> <tr> <th style="text-align: center;"><u>Nonrecurring Charge</u></th> <th colspan="2" style="text-align: center;"><u>Monthly Rate</u></th> </tr> </thead> <tbody> <tr> <td style="text-align: center;"><u>9.6 Kbps/56 Kbps</u></td> <td style="text-align: center;"><u>9.6 Kbps</u></td> <td style="text-align: center;"><u>56 Kbps</u></td> </tr> <tr> <td style="text-align: center;">\$100.00</td> <td style="text-align: center;">\$75.00</td> <td style="text-align: center;">\$130.00</td> </tr> </tbody> </table>	<u>Nonrecurring Charge</u>	<u>Monthly Rate</u>		<u>9.6 Kbps/56 Kbps</u>	<u>9.6 Kbps</u>	<u>56 Kbps</u>	\$100.00	\$75.00	\$130.00	
<u>Nonrecurring Charge</u>	<u>Monthly Rate</u>									
<u>9.6 Kbps/56 Kbps</u>	<u>9.6 Kbps</u>	<u>56 Kbps</u>								
\$100.00	\$75.00	\$130.00								



**XVIII. ADVANCED COMMUNICATIONS NETWORKS** (Continued)

b. Usage Rates		
	<u>NRC</u>	<u>Monthly Rate</u>
(1) 9.6 Kbps		
12 Logical Channels	---	\$48.00
22 Logical Channels	---	88.00
32 Logical Channels	---	128.00
(2) 56 Kbps		
32 Logical Channels	---	128.00
60 Logical Channels	---	240.00
90 Logical Channels	---	360.00
<b>C. <u>Frame Relay Service</u></b> <sup>18</sup>		
1. <i>Service Description</i>		
<p>Frame Relay Service (FRS) is a "fast packet" network service that permits the transmission of data at speeds of 56 Kbps up to 1.544 Mbps using Permanent Virtual Circuits (PVCs).</p>		
<p>PVCs are logical circuits that define a specific path for data sent by the customer to another location. These circuits are virtual because they are established in software tables and do not tie up capacity when not in use. This also allows multiple PVCs to be defined over a single access line, thereby providing a single access line the capability to transmit data to multiple destinations.</p>		
<p>In operation of Frame Relay Service, customer premises equipment, such as routers, encapsulate arriving data into variable length frames. These frames contain information identifying which PVC in the network should be used to forward the frame to the proper destination. The customer premises equipment then sends the frame into the Frame Relay network. The Frame Relay switch reads identifying information and routes the frame to the proper destination based on a pre-established PVC.</p>		
<p>The statistical multiplexing Frame Relay switches are able to provide shared network resources to end users of this service.</p>		
<p>Frame Relay conforms to Consultative Committee for International Telegraph and Telephone (CCITT) and American National Standards Institute (ANSI) publications T1.602, T1.606, T1.617 and T1.618.</p>		

<sup>18</sup> Effective May 21, 2003, Frame Relay Service as provided in Section XVIII.C. is no longer available to new customers. Existing OPP customers may continue their service until their OPP expires or their service is disconnected, whichever occurs first. Existing month-to-month customers may continue their service until May 21, 2008 or until their service is disconnected, whichever occurs first. Moves, additions, or changes will not be permitted.

**XVIII. ADVANCED COMMUNICATIONS NETWORKS** (Continued)

<p><i>2. Service Provisioning</i></p> <p>Frame Relay is a transport service that facilitates the exchange of variable length information units (frames) between end user connections by way of assigned virtual connections. Each frame is passed to the Frame Relay network with an address that specifies the virtual connection.</p>	
<p>Variable frame length capability is useful in communications between asynchronous Local Area Networks (LANs) and for transport of synchronous data traffic. Frame Relay is capable of handling the requirements of bursty data sources because of the ability of the service to allocate additional bandwidth when not in use by other sources.</p>	
<p>Frame Relay is provided to the customer in the form of Frame Relay with Port Only, which does not include access to the network, and Permanent Virtual Circuits. The access component, which provides the customer access to the customer's serving wire center is provided in Section VI.B.. The Frame Relay with Port Only is provided for digital Special Access Line connections to the network supporting Frame Relay Service.</p>	
<p>Frame Relay Service is provisioned using 56 Kbps, 128 Kbps, 256 Kbps, 384 Kbps or 1.544 Mbps ports, depending upon the customer's networking requirements. The actual throughput of aggregated PVC bandwidths in use at the same time on the same port cannot exceed the port speed. Since all PVCs need not be in use at the same time, it is possible for the total bandwidth of all PVCs associated with one Frame Relay Access Line to exceed the bandwidth of that Frame Relay Access Line. This relationship is referred to as over-subscription and when this occurs, there can be no guarantee that the bandwidth defined for that PVC will be available at any point in time.</p>	
<p>If the information provided by the customer on the requested PVC's results in an interstate arrangement, the PVC falls under federal jurisdiction and the Committed Information Rate (CIR) from the Company's FCC tariff is applicable.</p>	
<p>No PVC can have a greater bit rate than the bit rate of the associated access line.</p>	
<p>A PVC must be associated with at least one (1) Frame Relay Port. A Frame Relay Port can be associated with multiple PVCs.</p>	
<p>A customer subscribing to a PVC will be referred to as the Controller of the Frame Relay Port. A customer may request data transmission capability to another customer. Both customers must have a Frame Relay Access Line and Frame Relay Port. The Controller of each Frame Relay Access Line must have written permission from the Controller(s) of each of the Frame Relay Access Lines to which a PVC is requested.</p>	
<p>The Frame Relay Port and/or PVC are ordered and billed independently and can have different customers as Controllers.</p>	
<p>The Company does not undertake to originate data, but offers the use of its service components, where available, to customers for the purpose of transporting customer-originated data.</p>	
<p>Frame Relay Service is available where facilities and conditions permit.</p>	

**XVIII. ADVANCED COMMUNICATIONS NETWORKS** (Continued)

<p><b>3. Obligations of the Company</b></p> <p>In addition to the general conditions described in Section III., when a customer orders a PVC which is relayed to other Local Exchange Carriers, Interexchange Carriers or other Frame Relay networks, the Company will provide advisory assistance as a part of the establishment of this PVC.</p>	
<p>The Company has the service responsibility up to and including the network interface.</p>	
<p><b>4. Obligations of the Customer</b></p> <p>In addition to the general conditions described in Section III.:</p> <ul style="list-style-type: none"> <li>- The customer's Frame Relay terminal equipment has the responsibility for retransmitting frames which are discarded due to errors or network congestion.</li> </ul>	
<ul style="list-style-type: none"> <li>- The customer, upon request, shall furnish such information as may be required to permit the Company to design and maintain the Frame Relay Service it offers and to assure that the service arrangement is in compliance with the regulations contained herein.</li> </ul>	
<ul style="list-style-type: none"> <li>- It shall be the responsibility of the customer to ensure the continuing compatibility of the customer-provided equipment (CPE) that is used in conjunction with the Frame Relay Service. The CPE shall be in compliance with Commission rules and regulations.</li> </ul>	
<ul style="list-style-type: none"> <li>- The customer shall be responsible for obtaining permission for the Company's agents or employees to enter the premises of the customer or its users at any reasonable hour for the purpose of installing, inspecting, repairing, or, upon termination of the service, removing the service components of the Company.</li> </ul>	
<p><b>5. Rate Regulations</b></p> <p>a. Minimum Period</p> <p>The minimum period for Frame Relay Service is one month, except when provided under an Optional Payment Plan (OPP) arrangement. The regulations applicable to Frame Relay Service under an OPP arrangement are specified in XVIII.C.5.d..</p>	
<p>When PVCs are added to existing Frame Relay Service, the minimum period for the added PVCs is one month, except when provided under an OPP arrangement. The regulations applicable to Frame Relay Service under an OPP arrangement are specified in XVIII.C.5.d..</p>	

**XVIII. ADVANCED COMMUNICATIONS NETWORKS** (Continued)

<p>b. Rate Elements</p> <p>In addition to the appropriate Service Installation and Ordering Charges as set forth in Section VI.F., the following charges applies.</p> <p>(1) Frame Relay with Port only</p> <p>A nonrecurring charge and a monthly rate, based on the speed of the port connection (i.e., 56 Kbps, 128 Kbps, 256 Kbps, 384 Kbps, or 1.544 Mbps), apply per port for each Frame Relay digital Special Access Line connection to the network supporting Frame Relay Service. Each port includes one PVC, and can accommodate multiple PVCs. For Special Access Lines, refer to Section VI.B..</p>	
<p>(2) Frame Relay PVC – IntraLATA</p> <p>A nonrecurring charge and a monthly rate apply for each subsequent PVC added. These charges are in addition to the Subsequent Ordering Charge - Special Access as set forth in Section VI.F.. This rate is applicable for intraLATA service connections.</p>	
<p>(3) Frame Relay PVC – Statewide</p> <p>A monthly rate applies for the PVC Committed Information Rate (CIR) capacity for each statewide PVC requested by the customer. This rate allows the customer connectivity to any other customer site within the state.</p>	
<p>Customers may purchase Priority 1 or Priority 2 PVCs to prioritize PVCs at a higher rate and in lieu of CIR-PVCs. Priority PVC will help to ensure maximum performance and satisfaction for applications such as voice over Frame Relay.</p>	
<p>(4) If the information provided by the customer on the requested PVC's results in an interstate arrangement, the PVC falls under federal jurisdiction and the Committed Information Rate (CIR) from the Company's FCC tariff is applicable.</p>	
<p>c. Rate Application</p> <p>A customer may access Frame Relay Service (FRS) via Company provided digital special access facilities offered under Section VI.B.. When a customer utilizes a special access line to access FRS, the associated regulations, rates and charges for such facilities shall apply in addition to the rates and charges associated with the FRS rate elements.</p>	
<p>A customer utilizing special access facilities to access FRS would incur the monthly rate and nonrecurring charge associated with the Frame Relay with Port Only charge as set forth under XVIII.C.6.a..</p>	
<p>When a customer orders additional PVCs or changes PVC assignments on a Frame Relay port after initial port installation, the Frame Relay PVC nonrecurring charge shall apply per PVC added or changed. This charge is in addition to the Subsequent Ordering Charge-Special Access, as set forth in Section VI.F.1.d..</p>	

**XVIII. ADVANCED COMMUNICATIONS NETWORKS** (Continued)

<p>The Subsequent Activity Charge is applicable anytime a customer makes a change to the port termination speed and there is no change to the access link. This charge is in addition to the Subsequent Ordering Charge-Special Access, as set forth in Section <i>VI.F.1.d.</i>. Changing the speed of the access link will incur an installation charge for the new access link and an installation charge for the new port termination. These charges are in addition to the Initial Ordering Charge-Special Access, set forth in Section <i>VI.F.1.d.</i>.</p>	
<p>The Frame Relay with Port only and PVC are ordered and billed independently and can have different Controllers, as discussed under <i>XVIII.C.2.</i>. A request by one customer to discontinue a PVC does not result in the disconnection of the Frame Relay Port. Only the Controller of a Frame Relay Port may authorize a disconnect of that line.</p>	
<p>d. Optional Payment Plan (OPP)</p> <p>(1) General</p> <p>(a) The terms and conditions specified herein are applicable to Frame Relay Service and are in addition to other regulations as specified in this tariff.</p>	
<p>(b) Only the Frame Relay with Port Only rate element is available under an OPP. All other associated rate elements or additional features are available at the standard month-to-month tariffed rates and regulations, except, for Fractional T1 when ordered as an OPP and is used in conjunction with Frame Relay Service. The regulations applicable to Fractional T1 OPP are specified in Section <i>VI.F.12.</i>.</p>	
<p>(c) Frame Relay with Port Only rates will not be greater than standard month-to-month Port rate.</p>	
<p>(d) Payment periods of one year, three year, and five year are available to all customers at the applicable rates set forth in <i>XVIII.C.6.</i> regardless of when they subscribe to an OPP arrangement.</p>	
<p>(e) The customer must designate on the ASR the payment period for the OPP.</p>	
<p>(2) Changes in Length of OPP Period</p> <p>Prior to the completion of the selected OPP period, the customer may elect to convert to a new OPP period of the same or different length, subject to the following conditions:</p> <ul style="list-style-type: none"> <li>- No credit toward the new payment period will be given for payments made under the original OPP arrangement.</li> </ul>	
<ul style="list-style-type: none"> <li>- Nonrecurring charges will not be reapplied for existing service(s).</li> </ul>	
<ul style="list-style-type: none"> <li>- If the new OPP period is shorter in length than the time remaining under the existing OPP, the change to the new OPP period constitutes a disconnect of the existing OPP service and termination liability charges as outlined in Section <i>III.D.5.</i> will apply.</li> </ul>	

**XVIII. ADVANCED COMMUNICATIONS NETWORKS** (Continued)

<p>(3) Renewal Options</p> <p>See End of Term Options, <i>III.D.5.c.</i> under Termination Liability.</p>	
<p>(4) Notification of Discontinuance</p> <p>An ASR for discontinuance of an OPP arrangement must be received by the Company at least thirty (30) days prior to actual disconnect of service. Monthly charges will apply for a period of thirty (30) days from the date the Company receives disconnect notification or until the requested disconnect date, whichever period is longer.</p>	
<p>(5) Upgrade to Higher Speed Service</p> <p>Customers may elect to upgrade service(s) to a higher speed during an OPP period, subject to the following conditions:</p> <ul style="list-style-type: none"><li>- The upgraded service will be subject to all appropriate nonrecurring charges.</li></ul>	
<ul style="list-style-type: none"><li>- Termination liability charges will not apply as long as the upgraded service remains connected at the same point of termination(s) or meets the requirements set forth in Section <i>VI.F.4.b.(2)</i>.</li></ul>	
<ul style="list-style-type: none"><li>- See <i>III.D.4.d.</i> for exceptions to Termination Liability.</li></ul>	
<p>(6) Termination Liability</p> <p>See Section <i>III.D.</i>.</p>	
<p>(7) Termination Without Liability</p> <p>During an OPP period, should the currently effective rate for a customer service increase, the customer may, at their option, terminate the OPP arrangement without penalty or liability.</p>	

**XVIII. ADVANCED COMMUNICATIONS NETWORKS** (Continued)

6. Rates and Charges		
a. Frame Relay with Port Only, each <sup>19</sup>		
	<u>Nonrecurring Charge</u>	<u>Monthly Rate</u>
(1) 56 Kbps (DDS) <sup>20</sup>		
Month-to-Month	\$95.00	\$17.00
One Year OPP	95.00	15.75
Three Year OPP	95.00	14.50
Five Year OPP	95.00	13.50
(2) 128 Kbps (2 x 64 Kbps) <sup>20</sup>		
Month-to-Month	\$250.00	\$25.00
One Year OPP	250.00	23.00
Three Year OPP	250.00	21.50
Five Year OPP	250.00	20.00
(3) 256 Kbps (4 x 64 Kbps) <sup>20</sup>		
Month-to-Month	\$250.00	\$50.00
One Year OPP	250.00	47.00
Three Year OPP	250.00	43.50
Five Year OPP	250.00	40.00
(4) 384 Kbps (6 x 64 Kbps) <sup>20</sup>		
Month-to-Month	\$250.00	\$75.00
One Year OPP	250.00	70.00
Three Year OPP	250.00	65.00
Five Year OPP	250.00	60.00
(5) 1.544 Mbps (DS1) <sup>20</sup>		
Month-to-Month	\$250.00	\$305.00
One Year OPP	250.00	285.00
Three Year OPP	250.00	265.00
Five Year OPP	250.00	245.00

<sup>19</sup> Includes (1) PVC.

<sup>20</sup> Refer to Section VI.G. for the appropriate Special Access Facilities rate.

**XVIII. ADVANCED COMMUNICATIONS NETWORKS** (Continued)

b. Frame Relay Permanent Virtual Circuit, each		
	Nonrecurring <u>Charge</u>	Monthly <u>Rate</u>
(1) IntraLATA PVC		
Month-to-Month	\$10.00	\$7.50
One Year OPP	10.00	7.00
Three Year OPP	10.00	6.50
Five Year OPP	10.00	6.00
(2) Statewide CIR and Priority PVCs based on CIR requested <sup>21</sup>		
0 - 32 Kbps CIR	---	\$25.00
Priority 1	---	31.25
Priority 2	---	27.50
33 - 64 Kbps CIR	---	45.00
Priority 1	---	56.25
Priority 2	---	49.50
65 - 96 Kbps CIR	---	60.00
Priority 1	---	75.00
Priority 2	---	66.00
97 - 128 Kbps CIR	---	70.00
Priority 1	---	87.50
Priority 2	---	77.00
129 - 192 Kbps CIR	---	95.00
Priority 1	---	118.75
Priority 2	---	104.50
193 - 256 Kbps CIR	---	115.00
Priority 1	---	143.75
Priority 2	---	126.50
257 - 320 Kbps CIR	---	130.00
Priority 1	---	162.50
Priority 2	---	143.00

*Continued on next page...*

<sup>21</sup> PVCs which are deemed to be interstate in nature will fall under federal jurisdiction and the resulting CIR will be billed at rates from the Company's FCC tariff.



**XVIII. ADVANCED COMMUNICATIONS NETWORKS** (Continued)

Continued from previous page...	<u>Nonrecurring Charge</u>	<u>Monthly Rate</u>
321 - 384 Kbps CIR	---	\$145.00
Priority 1	---	181.25
Priority 2	---	159.50
385 - 512 Kbps CIR	---	170.00
Priority 1	---	212.50
Priority 2	---	187.00
513 - 768 Kbps CIR	---	195.00
Priority 1	---	243.75
Priority 2	---	214.50
769 - 1152 Kbps CIR	---	225.00
Priority 1	---	281.25
Priority 2	---	247.50
1.153 – 1.536 Mbps CIR	---	250.00
Priority 1	---	312.50
Priority 2	---	275.00
1.537 – 4 Mbps CIR	---	325.00
Priority 1	---	406.25
Priority 2	---	357.50
4.001 – 10 Mbps CIR	---	710.00
Priority 1	---	887.50
Priority 2	---	781.00
10.001 – 15 Mbps CIR	---	1,000.00
Priority 1	---	1,250.00
Priority 2	---	1,100.00
15.001 – 20 Mbps CIR	---	1,250.00
Priority 1	---	1,562.50
Priority 2	---	1,375.00
20.001 - 25 Mbps CIR	---	1,475.00
Priority 1	---	1,843.75
Priority 2	---	1,622.50
25.001 - 30 Mbps CIR	---	1,675.00
Priority 1	---	2,093.75
Priority 2	---	1,842.50
<i>Continued on next page...</i>		

**XVIII. ADVANCED COMMUNICATIONS NETWORKS** (Continued)

Continued from previous page...	<u>Nonrecurring Charge</u>	<u>Monthly Rate</u>
30.001 – 35 Mbps CIR	---	\$1,675.00
Priority 1	---	2,093.75
Priority 2	---	1,842.50
35.001 - 40 Mbps CIR	---	2,150.00
Priority 1	---	2,687.50
Priority 2	---	2,365.00
40.001 - 45 Mbps CIR	---	2,375.00
Priority 1	---	2,968.75
Priority 2	---	2,612.50
<b>D. <u>Asynchronous Transfer Mode (ATM) Service</u><sup>22</sup></b>		
<b>1. <i>Service Description</i></b>		
Asynchronous Transfer Mode (ATM) Service is a form of "fast packet" switching service for high speed networks which require flexible bandwidth, high-performance transport and switching for connectivity between and among widely distributed customer locations. ATM is a cell-based, connection-oriented, switching and multiplexing technology designed to be a fast general purpose transfer mode for multiple services.		
ATM Network Service conforms to protocol standards created by the ITU-T (Telecommunication Standardization Bureau of the International Telecommunication Union), formerly Consultative Committee for International Telegraph and Telephone (CCITT) and American National Standards Institute (ANSI), publications T1.511, T1.627, and T1.630.		
ATM is a high-bandwidth medium with low delay and has the capability to be switched to a specific destination.		
ATM Service is available where facilities and conditions permit.		

<sup>22</sup> Effective December 22, 2004, this service is no longer available to new customers. Existing customers on an OPP may continue their service until their OPP expires or their service is disconnected, whichever occurs first. Moves, additions or changes will not be permitted.

**XVIII. ADVANCED COMMUNICATIONS NETWORKS** (Continued)

<p><b>2. Service Provisioning</b></p> <p>ATM is a data networking technology that uses 53 byte cells, consisting of a 5 byte header which contains addressing, payload type and network priority information, and a 48 byte payload for data. The cells are transmitted through an ATM network in a "real time" (low delay in transmission) or "non-real time" sensitive manner on virtual channels.</p>	
<p>ATM Service can be provisioned over DS1, DS3, OC3c, and OC12c access channels.</p> <p>a. UNI Port and Access Line</p> <p>Customers can subscribe to ATM Service based on the speed of the port connection (i.e., DS1, DS3, OC3c or OC12c facilities) applicable for each physical connection to the network switch supporting ATM service. A port is the entry point on the switch to which the customer is connected. Ports are available which allow connection to the ATM network at speeds of DS1 to OC12c. Each port can accommodate multiple PVCs. UNI Port and Access Lines are available on a one (1), three (3) or five (5) year Optional Payment Plan (OPP).</p>	
<p>b. UNI Port Only</p> <p>Customers can order port only access based on the speed of port connection (i.e., DS1, DS3, OC3c or OC12c facilities) applicable for each access line or digital private line connection to the network switch supporting ATM Service. Each port can accommodate multiple PVCs. UNI Port Only is available on a one (1), three (3) or five (5) year OPP. The associated regulations, rates and charges from Section VI. are in addition to the rates and charges associated with the ATM rate elements. Local channel, interoffice channel mileage and hub termination rates for DS3, OC3c, and OC12c access channels and/or interoffice channels shall be provisioned on an Individual Case Basis (ICB).</p>	
<p>PVCs are logical circuits that define a specific path for data sent by the customer to another location. These circuits are virtual because they are established in software tables and do not tie up capacity when not in use. This also allows multiple paths (PVCs) to be defined on any given port, thereby providing a single access line the capability to transmit data to multiple destinations.</p>	
<p>Permanent Virtual Path (PVP) provides for aggregation of multiple PVCs into a single path. The traffic management parameters for all PVCs in the PVP must be defined at the same level of service. All PVCs in the PVP must have the same originating and terminating end ports. The applicable Sustained Cell Rate (SCR) and Peak Cell Rate (PCR) rates apply for the aggregate SCR and PCR of all the PVCs in the PVP.</p>	
<p>Customers can subscribe to pricing scheme(s), which charge for SCR. SCR is an amount of bandwidth which the Company commits to providing in the network for customer traffic. SCR is set for every PVC defined.</p>	

**XVIII. ADVANCED COMMUNICATIONS NETWORKS** (Continued)

<p>Company ATM switches are responsible for guaranteeing the traffic priority parameter ordered by the customer. Traffic prioritization parameters refer to priorities given to cell transmissions and sensitivity of cells to delay variation and loss within the network. Constant Bit Rate (CBR) traffic is given first priority, Variable Bit Rate-Real Time (VBR-rt) traffic is given second priority and Variable Bit Rate-Non Real Time (VBR-nrt) traffic is given third priority, based upon the traffic in the network at any given point in time.</p>	
<p>There are three traffic prioritization parameter categories:</p> <ul style="list-style-type: none"> <li>- Constant Bit Rate (CBR): An ATM traffic management parameter that supports the transmission of a continuous bit stream of traffic from those applications such as video, voice, and circuit emulation, which require rigorous timing control and performance parameters.</li> </ul>	
<ul style="list-style-type: none"> <li>- Variable Bit Rate-Real Time (VBR-rt): An ATM traffic management parameter that allows for applications where a PVC requires low cell delay variation. For example, VBR-rt would be utilized for applications such as variable bit rate video compression, and packet voice and video, which are somewhat tolerant of delay.</li> </ul>	
<ul style="list-style-type: none"> <li>- Variable Bit Rate-Non Real Time (VBR-nrt): An ATM traffic management parameter that allows for applications where a PVC can tolerate larger cell delay variation than VBR-rt. For example VBR-nrt would be utilized for applications such as data file transfers.</li> </ul>	
<p>In ATM transmission, PCR is the highest available rate of information that can be transferred on a VBR connection, and the continuous cell rate allowed for CBR. Cells exceeding the SCR and below the PCR will be limited to a maximum burst size.</p>	
<p>Customers may purchase PCR in 1 Mbps increments.</p>	
<p>Frame Relay to ATM Service Interworking:</p> <p>An end user may send data from a premises location with a Frame Relay User to Network Interface (UNI) or a Network to Network Interface (NNI) to another premises with an ATM Service UNI. Frame Relay to ATM Service Interworking provides for the conversion of Frame Relay packets to ATM cells and the conversion of ATM Cells to Frame Relay packets. Frame Relay Service(s) and ATM Service(s) must be established in order to provision a Frame Relay to ATM Service Interworking PVC. This conversion occurs between bandwidth equivalent CIR (Committed Information Rates) and SCR. Cell conversion occurs at VBR-nrt.</p>	
<p>If the information provided by the customer on the requested PVCs results in an interstate arrangement, the PVC falls under federal jurisdiction and the PVC rate from the Company's FCC tariff is applicable.</p>	
<p><b>3. <i>Obligations of the Telephone Company</i></b></p> <p>The Company is responsible for service up to and including the network interface device.</p>	
<p>The Company shall provision service over facilities suitable for ATM transmission, where available, for the effective maximum data rates of a DS1 (1.536 Mbps per second), DS3 (44.2 Mbps per second), OC3c (155 Mbps per second, concatenated) or OC12c (622.08 Mbps per second, concatenated).</p>	

**XVIII. ADVANCED COMMUNICATIONS NETWORKS** (Continued)

<p>Occasionally, in order to perform software updates and other maintenance, it may be necessary to take the ATM switch out of service, during the predetermined maintenance window of 12:01 AM to 6:00 AM. In these cases, all attempts will be made to notify the customer in advance as to the time and duration of these outages. The Company reserves the right to temporarily interrupt ATM Service at other times in emergency situations.</p>	
<p><b>4. Obligations of the Customer</b></p> <p>The customer must provide compatible equipment in accordance with interface specifications defined in ANSI Standards for ATM services.</p>	
<p>The customer is responsible for the installation, operation and maintenance of any Customer Provided Equipment (CPE).</p>	
<p>The customer must specify the speed for each ATM port ordered. The customer must specify the SCR, PCR, and traffic management parameters at the time of the order for each PVC.</p>	
<p>The customer shall be responsible for obtaining permission for the Company's agents or employees to enter the customer's designated location(s) at any reasonable hour for the purpose of installing, inspecting, repairing, or, upon termination of the service, removing the service components of the Company.</p>	
<p>The customer must provide to the Company a point of contact with information to include the contact name, telephone number, mailing address, and electronic mail (e-mail) address for notification purposes.</p>	
<p><b>5. Rate Regulations</b></p> <p>a. Minimum Period</p> <p>The minimum period for ATM Network Service is one year, except when provided under an OPP arrangement. The regulations applicable to ATM Network Service provided under an OPP arrangement are specified under <i>XVIII.D.6.</i></p>	
<p>b. Rate Elements</p> <p>(1) ATM UNI Port and Access Line</p> <p>A nonrecurring charge and a monthly rate, based on the speed of the port connection (i.e., DS1, DS3, OC3c, or OC12c) apply per port for each ATM access line connection to the network supporting ATM Service. Each port can accommodate multiple PVCs.</p>	
<p>(2) ATM UNI Port</p> <p>A nonrecurring charge and a monthly rate, based on the speed of the port connection (DS1, DS3, OC3c or OC12c), apply per port for each ATM access channel connection to the network supporting ATM Service. Each port can accommodate multiple PVCs.</p>	

**XVIII. ADVANCED COMMUNICATIONS NETWORKS** (Continued)

<p>Special access rates to the nearest Company ATM switch are in addition to the ATM UNI Port charges and are available from Section VI. or this tariff. DS3, OC3c, and OC12c special access rate elements will be provided on an Individual Case Basis (ICB).</p>	
<p>(3) Sustained Cell Rate-Permanent Virtual Circuit (SCR-PVC)</p> <p>A monthly rate applies for each PVC based on the SCR and traffic management parameter requested by The customer. SCR cannot exceed the port size.</p>	
<p>(4) Sustained Cell Rate – Additional</p> <p>Sustained Cell Rate - Additional provides for the customer to order additional SCR above the 50 Mbps available in this tariff. A monthly recurring charge applies for each 5 Mbps of Sustained Cell Rate - Additional ordered based on the traffic management parameter selected. This charge is in addition to the SCR.</p>	
<p>(5) Peak Cell Rate (PCR)</p> <p>Peak Cell Rate is the maximum data rate a customer may send data into the ATM network on a PVC. The PCR on a PVC is defined as the SCR plus the incremental PCR. Incremental PCR is available in 1 Mbps increments and is in addition to the SCR.</p>	
<p>(6) Frame Relay to ATM Service Interworking</p> <p>A monthly recurring charge applies, based on SCR ordered, for a Frame Relay to ATM Service interworking PVC. Service includes SCR-PVC rates and equivalent Frame Relay CIR-PVC rates and provides for bandwidth transmission through the network. The minimum period for a Frame Relay Service to ATM Service Interworking PVC is one (1) month.</p>	
<p>6. <i>Optional Payment Plan (OPP)</i></p> <p>a. General</p> <p>The terms and conditions specified herein are applicable to ATM Service and are in addition to other regulations as specified in this Tariff.</p>	
<p>The ATM UNI Port with Access Line and ATM UNI Port Only rate elements are available under an OPP. Nonrecurring charges apply for initial OPP orders. NRC's will not be applied for changes in OPP lengths of Ports or Port and Access Lines. Digital special access lines and additional features are available at their tariffed rates and regulations.</p>	
<p>Three (3) year and five (5) year OPP rates will be equal to or less than the one (1) year OPP rates. Decreases to the one (1) year OPP rates will flow through to the three (3) year and five (5) year OPP rates.</p>	
<p>Payment periods of one (1) year, three (3) years, and five (5) years are available to all customers regardless of when they subscribe to an OPP arrangement.</p>	
<p>The customer must designate the payment period for the OPP.</p>	

**XVIII. ADVANCED COMMUNICATIONS NETWORKS** (Continued)

<p>Inside moves as specified in Section VI.F.4.a. will not incur termination liability charges.</p>	
<p>Outside moves as specified in Section VI.F.4.b. will allow The customer to retain the same OPP payment period. Any other move will be treated as a disconnect of the service and termination liability charges will apply.</p>	
<p>b. Changes in Length of OPP Period</p> <p>Prior to the completion of the selected OPP period, the customer may elect to convert to a new OPP period of the same or different length, subject to the following conditions:</p> <ul style="list-style-type: none"> <li>- No credit toward the new payment period will be given for payments made under the original OPP arrangement.</li> </ul>	
<ul style="list-style-type: none"> <li>- Nonrecurring charges will not be reapplied for existing service(s).</li> </ul>	
<ul style="list-style-type: none"> <li>- If the new OPP period is shorter in length than the time remaining under the existing OPP, the change to the new OPP period constitutes a discontinuance of the existing OPP service and termination liability charges apply.</li> </ul>	
<p>c. Renewal Options</p> <p>At the expiration of an OPP period, the Company will continue the service with existing rates unless the customer chooses to convert to a different OPP period or discontinue service.</p>	
<p>Conversion to a different OPP period will require the customer to submit a change order. Conversion of existing OPP service to a different OPP period will be allowed without application of any nonrecurring or ordering charges.</p>	
<p>d. Notification of Discontinuance</p> <p>A request for discontinuance of an OPP arrangement must be received by the Company at least thirty (30) days prior to actual disconnect of service. Recurring charges will apply for a period of thirty (30) days from the date the Company receives disconnect notification or until the requested disconnect date, whichever period is longer.</p>	
<p>e. Upgrade to Higher Speed Service</p> <p>The customers may elect to upgrade service(s) to a higher speed during an OPP period, subject to the following conditions:</p> <p>The order to discontinue a service at an existing speed or capacity and the order for the upgraded service are received by the Company at the same time.</p>	
<p>The fixed period plan for the upgraded service(s) meets or exceeds the remaining length of the existing fixed-period plan.</p>	
<p>The total monthly rate of the new agreement is equal to or greater than the total monthly rate of the existing agreement period.</p>	

**XVIII. ADVANCED COMMUNICATIONS NETWORKS** (Continued)

<p>The monthly rates for the upgraded service and/or service elements will be those in effect at the time of the service upgrade.</p>	
<p>Termination Liability charges will not apply as long as the upgraded service remains connected at the same point of termination(s) and is provided by the Company.</p>	
<p>Nonrecurring Charges will not apply to the upgraded Port or Port and Access Line. Special construction charges, if appropriate, may apply.</p>	
<p>f. Termination Liability</p> <p>When an OPP arrangement is discontinued prior to the end of the period, termination liability charges, as set forth below, will apply based on the remainder of the OPP period in effect at the time of disconnect.</p>	
<p>Charges will also be applicable if the number of services falls below the minimal amount of ATM services (port only or port and access) defined at the start of the contract. Charges are set forth below with the penalty assessed for each service that falls below the minimum number multiplied by the number of months required to attain the minimum contract commitment.</p>	
<p>One-Year OPP – fifty percent (50%) of any remaining portion of the first year's recurring charges for the in-service quantity.</p>	
<p>Three-Year OPP – fifty percent (50%) of any remaining portion of the first year's recurring charges. In addition, for any remaining portion of the second and third years, the customer will be liable for ten percent (10%) of the total monthly recurring charges in that time period for the in-service quantity.</p>	
<p>Five-Year OPP – fifty percent (50%) of any remaining portion of the first year's recurring charges. In addition, for any remaining portion of the second through fifth years, the customer will be liable for twenty percent (20%) of the total monthly recurring charges in that time period for the in-service quantity.</p>	
<p>g. Termination Without Liability</p> <p>During an OPP period, should the currently effective rate for the customer's service increase, the customer may, at his option, terminate the OPP arrangement without penalty or liability.</p>	
<p>h. Credit of Termination</p> <p>Credit of termination liability charges for ATM services may be applicable in the case of re-establishment of similar ATM service of equal to or higher speeds within six (6) months of termination for the same length of the OPP. The amount of credit will be one-sixth (1/6) of the penalty times the number of months service is re-established until the sixth month.</p>	



**XVIII. ADVANCED COMMUNICATIONS NETWORKS** (Continued)

7. Rates and Charges		
a. UNI Port and Access Line		
	<u>Nonrecurring Charge</u>	<u>Monthly Rate</u>
DS-1		
One Year	\$650.00	\$650.00
Three Years	650.00	525.00
Five Years	650.00	500.00
DS-3		
One Year	1,500.00	1,950.00
Three Years	1,500.00	1,750.00
Five Years	1,500.00	1,700.00
OC-3c		
One Year	1,500.00	2,100.00
Three Years	1,500.00	1,950.00
Five Years	1,500.00	1,800.00
OC-12c		
One Year	3,000.00	4,800.00
Three Years	3,000.00	4,600.00
Five Years	3,000.00	4,350.00

**XVIII. ADVANCED COMMUNICATIONS NETWORKS** (Continued)

b. UNI Port Only <sup>23</sup>	Nonrecurring <u>Charge</u>	Monthly <u>Rate</u>
DS-1		
One Year	\$650.00	\$180.00
Three Years	650.00	175.00
Five Years	650.00	170.00
DS-3		
One Year	1,500.00	400.00
Three Years	1,500.00	370.00
Five Years	1,500.00	350.00
OC-3c		
One Year	1,500.00	680.00
Three Years	1,500.00	650.00
Five Years	1,500.00	630.00
OC-12c		
One Year	3,000.00	1,500.00
Three Years	3,000.00	1,430.00
Five Years	3,000.00	1,380.00

---

<sup>23</sup> The associated regulations, rates and charges from Section IV. are in addition to the rates associated with these ATM rate elements. Local channel, interoffice channel mileage and hub termination rates for DS3, OC3c, and OC12c access channels and/or interoffice channels will be provided on an Individual Case Basis (ICB).

**XVIII. ADVANCED COMMUNICATIONS NETWORKS** (Continued)

c. Sustained Cell Rate – Permanent Virtual Circuit (SCR-PVC)			
(1)	<u>CBR</u>	Monthly Rate <u>VBR-rt</u>	<u>VBR-nrt</u>
0-32 Kbps	\$12.00	\$10.00	\$8.00
33-64 Kbps	22.50	18.75	15.00
65-96 Kbps	33.00	27.50	22.00
97-128 Kbps	43.50	36.25	29.00
129-192 Kbps	54.00	45.00	36.00
193-256 Kbps	63.00	52.50	42.00
257-320 Kbps	72.00	60.00	48.00
321-384 Kbps	81.00	67.50	54.00
385-512 Kbps	90.00	75.00	60.00
513-768 Kbps	97.50	81.50	65.00
769-1152 Kbps	105.00	87.50	70.00
1.153-1.56 Mbps	112.50	93.75	75.00
1.537-4 Mbps	180.00	150.00	120.00
4-6 Mbps	270.00	225.00	180.00
6-8 Mbps	360.00	300.00	240.00
8-10 Mbps	450.00	375.00	300.00
10-15 Mbps	495.00	412.50	330.00
15-20 Mbps	615.00	512.50	410.00
20-25 Mbps	735.00	612.50	490.00
25-30 Mbps	855.00	712.50	570.00
30-35 Mbps	975.00	812.50	650.00
35-40 Mbps	1,095.00	912.50	730.00
40-45 Mbps	1,200.00	1,000.00	800.00
46-50 Mbps	1,305.00	1,087.50	870.00
(2) Sustained Cell Rate (SCR) - Additional			
5 Mbps	105.00	87.50	70.00
d. Peak Cell Rate (PCR)			
		<u>Nonrecurring Charge</u>	<u>Monthly Rate</u>
1 Mbps, each		\$---	\$5.00

**XVIII. ADVANCED COMMUNICATIONS NETWORKS** (Continued)

e. Frame Relay to ATM Service Interworking	Nonrecurring Charge	Monthly Rate
0-32 Kbps	\$---	\$14.00
33-64 Kbps	---	26.25
65-96 Kbps	---	38.50
97-128 Kbps	---	50.75
129-192 Kbps	---	63.00
193-256 Kbps	---	73.50
257-320 Kbps	---	84.00
321-384 Kbps	---	94.50
385-512 Kbps	---	105.00
513-768 Kbps	---	113.75
769-1152 Kbps	---	122.50
1.153-1.536 Mbps	---	131.25
1.537-4 Mbps	---	210.00
4-6 Mbps	---	315.00
6-8 Mbps	---	420.00
8-10 Mbps	---	525.00
10-15 Mbps	---	577.50
15-20 Mbps	---	717.50
20-25 Mbps	---	857.50
25-30 Mbps	---	997.50
30-35 Mbps	---	1,137.50
35-40 Mbps	---	1,277.50
40-45 Mbps	---	1,400.00

<b>E. <u>Transport LAN Connection (TLC)</u><sup>24</sup></b>	
<b>1. <i>Service Description</i></b>	
<p>Transport LAN Connect (TLC) is a fiber optic-based intra-exchange and inter-exchange network transport service. TLC is a private network transport service that does not provide for direct inter-connection with public networks (e.g. Public ATM, Public Frame-Relay, etc.). TLC offers customers inter-sits transport of the following:</p> <ul style="list-style-type: none"> <li>10 Switched Ethernet Service (10 Mbps)</li> <li>100 Base TX Fast Ethernet (100 Mbps)</li> <li>DS1 (1.544 Mbps)</li> <li>ATM OC3c (155 Mbps)</li> </ul>	

<sup>24</sup> Offering is limited to existing customers at existing locations as of March 20, 2003.

**XVIII. ADVANCED COMMUNICATIONS NETWORKS** (Continued)

<p>TLC's recommended configuration conforms to protocol standards publications 802.3 for (10 Switched) and 802.3u for (100 Base-TX) created by the Institute of Electrical and Electronic Engineering and/or American National Standards Institute (ANSI), publications T1.511, T1.627, and T1.630.</p>	
<p>TLC is available where facilities and conditions permit.</p>	
<p><b>2. Service Provisioning</b></p> <p>The customer is responsible for facilities from customer's premises to the serving wire center. The Company will provision fiber, upon customer request, from the Special Construction section of this tariff on an individual case basis (ICB).</p>	
<p>TLC service can be provisioned for DS1, Ethernet, Fast Ethernet, and OC3c ATM UNI.</p>	
<p><b>3. Conditions</b></p> <p><b>a. Contract Termination Liability</b></p> <p>TLC services are offered on a contract basis for periods of one, two, three, or five years. All contracts are subject to the Contract Termination Liability (CTL). Prior to the expiration of the contract period, a customer must notify the Company of the customer's choice of the following options:</p> <ul style="list-style-type: none"> <li>- convert to a new contract period of the same or different length,</li> </ul>	
<ul style="list-style-type: none"> <li>- continue at the completed contract period's rate but on a month-to-month basis, or</li> </ul>	
<ul style="list-style-type: none"> <li>- discontinue service.</li> </ul>	
<p>If the customer does not notify the Company of one of the above options prior to the expiration of the contract period, then the Company will continue to bill the customer at the completed contract period's rate on a month-to-month basis.</p>	
<p>If prior to the expiration of a contract, the customer converts to a contract period with a longer period of time, the customer has the option of receiving credit for the elapsed time under the old contract toward the new contract period.</p>	
<p>If the customer orders additional service, subsequent to existing service, then the contract period for the added service will be coterminous with the contract period in effect for the existing service. The rate for the added service will be for the same contract period option as the existing service.</p>	

**XVIII. ADVANCED COMMUNICATIONS NETWORKS** (Continued)

<p>The Contract Termination Liability (CTL) will apply when any portion of this service that is subject to the CTL is terminated prior to completion of the elected contract period. The customer's liability will be equal to twenty-five percent (25%) of the monthly rate for the applicable service terminated times the number of months remaining in the contract period. Deletions to the customer's service will be subject to contract termination liability per the original contract with the exception of customers who migrate to Asynchronous Transfer Mode (ATM) service.</p>	
<p>b. Customer Requested Service Configuration Changes</p> <p>Applicable Special Access Ordering Charges as set forth in Section VI. under VI.G.1., Subsequent Ordering Charges, in the Company's Local tariff, will apply if the customer requests service configuration changes.</p>	
<p>c. Obligations of the Company</p> <p>The Company is responsible for service up to and including the TLC interface port.</p>	
<p>The Company shall provision service over facilities suitable for TLC transmission, where available, for the effective maximum line rate of a DS1 (1.544 Mbps), Ethernet (10 Mbps), Fast Ethernet (100 Mbps), or OC3c (155 Mbps) concatenated).</p>	
<p>Occasionally, in order to perform software updates and other maintenance, it may be necessary to take the TLC node out of service, during the predetermined maintenance window of 12:01 AM to 6:00 AM In these cases, all attempts will be made to notify the customer in advance as to the time and duration of these outages. The Company reserves the right to temporarily interrupt TLC service at other times in emergency situations.</p>	
<p>d. Obligations of the Customer</p> <p>The customer must provide compatible equipment in accordance with interface specifications defined in applicable IEEE and/or ANSI Standards.</p>	
<p>The customer is responsible for installation, operation and maintenance of any customer provided equipment (CPE).</p>	
<p>Customers who choose Ethernet (10 or 100 Mbps) must specify if they intend to utilize full or half duplex. Customers who choose OC3c (155 Mbps) must provide their virtual circuit requirements to the Company. All customers must specify the originating and terminating locations.</p>	
<p>The customer shall be responsible for obtaining permission for the Company's agents or employees to enter the customer's designated location(s) at any reasonable hour for the purpose of installing, inspecting, repairing, or, upon termination of the service, removing the service components of the Company.</p>	
<p>The customer must provide to the Company a point of contact with information to include the contact name, telephone number, mailing address, and electronic mail (email) address for notification purposes.</p>	

**XVIII. ADVANCED COMMUNICATIONS NETWORKS** (Continued)

<p>In order for the facilities to work properly it is recommended that the customer not exceed facility capacity by over-booking or over-subscribing the bandwidth of the inter-node links.</p>	
<p>e. Recommended Configurations</p> <p>The recommended TLC inter-node configurations include star (aka hub and spoke) and/or standard (non-split fiber) ring of up to eight nodes that are booked at up to one hundred percent (100%) of inter-node transport port bandwidth. These recommended configurations also include a mix of DS-1, Ethernet (10 Base-T), Fast Ethernet (100 Base-TX), and/or ATM OC3c interface ports at each node as required by customer’s specific applications.</p>	
<p>f. Configurations That Are Not Recommended</p> <p>(1) Over-Booked Configurations</p> <p>Over-booking of inter-node transport ports is not recommended due to their inherent degradation potential for quality and performance. In an over-booked configuration, the inter-node transport ports are allocated (booked) at over one hundred percent (100%). An example would be two Fast (100 Base-TX) Ethernet (100 Mbps each) interface ports competing for the bandwidth of a single OC3c (155 Mbps) inter-node transport port. In this example, the booking ratio is 200/155 Mbps or approximately one hundred thirty percent (130%) booking.</p>	
<p>(2) Split Fiber Ring Configurations</p> <p>Split fiber ring configurations carry inherent risk should one node fail or a fiber cut occur. In a split fiber ring configuration, the inter-node transport port’s transmit and receive fibers of a TLC node are split with the transmit fiber going to one TLC node while the receiving fiber goes to another TLC node.</p>	
<p>(3) Non-split Fiber Ring Configurations of More Than 8 Nodes</p> <p>Non-split fiber ring configurations of more than eight nodes are not recommended due to their inherent degradation potential for quality and performance. In a non-split fiber ring configuration, both the transmit and receive fibers of a TLC node’s first inter-node transport port are both interconnected to one TLC node and both the transmit and receive fibers of the additional TLC inter-node transport port are both interconnected to another TLC node.</p>	
<p>4. <i>Description</i></p> <p>a. Base TLC Node Infrastructure and Inter-Node Transport</p> <p>(1) OC3c Base Node</p> <p>(Base TLC platform with first OC3c inter-node transport port) Provides base TLC hardware/software platform (node) and node’s first inter-node OC3c transport port.</p>	

**XVIII. ADVANCED COMMUNICATIONS NETWORKS** (Continued)

<p>(2) Additional OC3c Inter-Node Transport Port</p> <p>Additional OC3c inter-node transport port to support bandwidth requirement of inter-site transport. Adds OC3c port to inter-node transport port to an existing OC3c Base Node. (Requires OC3c Base Node.)</p>	
<p>(3) OC3c Inter-Node Transport Inter-Office Facility Termination (Per inter-office termination)</p> <p>Provides termination of an inter-office facility transport required to support inter-office TLC inter-node transport configurations.</p>	
<p>(4) OC3c Inter-Node Transport Inter-Office Facility (Per airline mile)</p> <p>Provides inter-office facility transport required to support inter-office TLC inter-node transport configurations.</p>	
<p>b. TLC Interface Port</p> <p>(1) DS1 Circuit Interface Port (Per port)</p> <p>Provides port interface required to support point-to-point transport of DS-1 circuit. (Requires OC3c Base Node.)</p>	
<p>(2) 10 Base-T Interface Port (Per port)</p> <p>Provides port interface required to support point-to-point or multi-point transport of 10 Base-T Ethernet. (Requires OC3c Base Node.)</p>	
<p>(3) 100 Base-TX Interface Port (Per port)</p> <p>Provides port interface required to support point-to-point or multi-point transport of 100 Base-TX Ethernet. (Requires OC3c Base Node.)</p>	
<p>(4) OC3c ATM Interface Port (Per port)</p> <p>Provides ATM User-to-Network Interface (UNI) port required to support point-to-point or multi-point transport of ATM virtual circuits. (Requires OC3c Base Node.) Virtual circuit must be ATM adaptation layer 5 (AAL-5) unspecified bit rate (UBR) only.</p>	
<p>5. <i>Rate Regulation</i></p> <p>TLC service consists of Base Node, Additional Inter-Node Transport Port(s), Interface Port(s), Inter-Office Facility Mileage, and Inter-Office Facility Termination.</p> <p>a. OC3c Base Nodes</p> <p>OC3c Base Nodes are required on a per site basis, thus a minimum of two must be ordered for any point-to-point inter-site transport. For example, inter-site transport between locations A and B requires a OC3c Base Node at Site A and another OC3c Base Node at Site B.</p>	



**XVIII. ADVANCED COMMUNICATIONS NETWORKS** (Continued)

<p>b. Additional OC3c Inter-Node Transport Ports</p> <p>Additional OC3c Inter-Node Transport Ports are required on a per site basis, thus a minimum of two must be ordered for any additional point-to-point transport. For example, additional OC3c transport between locations A and B requires an Additional OC3c Inter-Node Transport Port at Site A and another Additional Transport Port at Site B. Requires an OC3c Base Node at each customer site, which includes the first OC3c Inter-Node Transport Port.</p>	
<p>c. DS1, 10 Base-T, 100 Base-TX, and OC3c ATM Interface Ports</p> <p>DS1, 10 Base-T, 100 Base-TX, and OC3c ATM Interface Ports are required on a per site basis, thus a minimum of two must be ordered for any point-to-point transport. For example, a DS1 circuit between locations A and B requires a DS1 Circuit Interface Port at Site A and another DS1 Circuit Interface Port at Site B. Requires a OC3c Base Node at each customer site, which includes the first OC3c Inter-Node Transport Port.</p>	
<p>d. OC3c Inter-Office Facility Termination</p> <p>OC3c Inter-Office Facility Termination is required to terminate the OC3c Inter-Node Transport. Two termination charges apply for each transport, one at each end.</p>	
<p>e. OC3c Inter-Node Transport Inter-Office Facility Mileage</p> <p>OC3c Inter-Node Transport Inter-Office Facility Mileage is charged on a per airline mile basis between OC3c Base Nodes. Requires a OC3c Base Node at each customer site, which includes the first OC3c Inter-Node Transport Port.</p>	

**XVIII. ADVANCED COMMUNICATIONS NETWORKS** (Continued)

6. Rates <sup>25</sup>	Nonrecurring Charge	Monthly Rate
OC3c Base Node		
1 Year	\$1,500.00	\$1,400.00
2 Year	1,500.00	1,150.00
3 Year	1,500.00	1,100.00
5 Year	1,500.00	1,000.00
Additional OC3c Inter-Node Transport Port		
1-year	500.00	600.00
2 Year	500.00	550.00
3 Year	500.00	500.00
5 Year	500.00	450.00
10 Base-T Interface Port Ethernet		
1-year	200.00	225.00
2 Year	200.00	200.00
3 Year	200.00	175.00
5 Year	200.00	150.00
100 Base-TX Interface Port Fast Ethernet		
1-year	200.00	500.00
2 Year	200.00	475.00
3 Year	200.00	450.00
5 Year	200.00	400.00
DS1 Circuit Interface Port		
1-year	200.00	175.00
2 Year	200.00	150.00
3 Year	200.00	125.00
5 Year	200.00	100.00
OC3c ATM Interface Port		
1-year	500.00	800.00
2 Year	500.00	750.00
3 Year	500.00	700.00
5 Year	500.00	600.00
OC3c Inter-Node Transport Inter-Office Facility Termination	---	160.00
OC3c Inter-Node Transport Inter-Office Facility Per airline mile	---	40.00

**XVIII. ADVANCED COMMUNICATIONS NETWORKS** (Continued)

<p><b>F. <u>Transport LAN Service (TLS)</u></b><sup>26</sup></p>	
<p><b>1. <i>Definitions</i></b></p> <p>In addition to the Definitions set forth in section <i>III.F.</i> of this tariff, the following definitions apply:</p> <p>Domain: A Virtual Local Area Network (VLAN) or a collection of circuits that belong to one (1) closed user group.</p>	
<p>Megabit Per Second (Mbps.): The speed at which data is being transferred in the network, where one Megabit Per Second equals to the transfer rate of one (1) million bits of data in one (1) second.</p>	
<p>Gigabit Per Second (Gbps): Data transfer rate for 1000 Mbps. The speed at which data is transferred through the network, where one Gigabit per second equals the transfer rate of one (1) billion bits of data in one (1) second.</p>	
<p>Nanometers (nm): Wavelength frequency equivalent to one (1) billionth of a meter.</p>	
<p><b>2. <i>Service Description</i></b></p> <p>Transparent LAN Service (TLS) is a high speed data service which uses a shared optical transport network to allow for the interconnection of Local Area Networks (LANs) across selected metropolitan areas. TLS delivers an interface of 10 Mbps, 100 Mbps, 1000 Mbps or 10 Gbps from the Customer's LANs to the shared network.</p>	
<p>TLS creates a network with the ability to function as a shared public network. TLS protects data privacy by using specialized screening software that permits subscribers to access only their data.</p>	
<p>TLS is available where facilities and conditions permit</p>	
<p>TLS is available in two (2) service types: Ethernet Multipoint Service (EMS) or Ethernet Relay Service (ERS). The customer must select either (EMS) or (ERS) as the service type for each domain.</p> <p><b>a. Ethernet Multipoint Service</b></p> <p>Ethernet Multipoint Service (EMS) is a connection-less Ethernet TLS service that allows connectivity among multiple customer designated locations within a LATA.</p>	

<sup>25</sup> All Contracts are subject to conditions for Contract Termination Liability.

<sup>26</sup> Offering is limited to existing customers at existing locations as of March 1, 2003.

**XVIII. ADVANCED COMMUNICATIONS NETWORKS** (Continued)

<p>With the EMS service type, Ethernet TLS protects data privacy by using closed user groups (CUGs), also known as virtual LANs. CUGs or virtual LANs are used to provide traffic separation, privacy and security between customers on the shared switch and backbone. An EMS domain is comprised of any number of access lines designated by the customer to be included in a closed user group (CUG) or virtual LAN. EMS provides multipoint-to-multipoint connectivity among all of the customer's access lines within a given domain. Subscribers in a CUG can only access their own data.</p>	
<p>b. Ethernet Relay Service</p> <p>Ethernet Relay Service (ERS) is a connection-oriented Ethernet TLS service that allows for point-to-point connectivity between customer designated locations within a LATA.</p>	
<p>With the ERS TLS service type, each Ethernet Virtual Circuit (EVC) establishes a virtual LAN or CUG. An ERS domain is comprised of any number of virtual LANs designated by the customer to be included in the ERS domain. ERS provides point-to-point connectivity between pairs of customer's User Network Interface (UNI) port with access lines, and shared network virtual circuits within a given domain.</p>	
<p>A customer may have more than one domain within a LATA, but connections between domains are not permitted. TLS may be used to access shared networks. In such cases, subscribers in a CUG can only access their own data.</p>	
<p>Four (4) EVC service classes are available for use with ERS service type:</p> <p>(1) ERS Standard (ERS-Std) and ERS Basic(ERS-B): designed for customer applications that do not require a Committed Information Rate (CIR) or low delay, where CIR = 0 and Excess Information Rate (EIR) = # of Mbps of the selected ERS-Std/ERS-B EVC service class.</p>	
<p>(2) ERS-Priority Data (ERS-PD): designed for customer applications which do not require low delay, but require a CIR, where CIR = # of Mbps of the selected ERS-PD EVC service class and EIR = # of Mbps of the selected ERS-PD EVC service class.</p>	
<p>(3) ERS Real Time (ERS-RT): designed for customer applications which require a CIR and low delay for some portion of their traffic, where CIR = # of Mbps of the selected ERS-RT EVC service class and EIR = 0.</p>	
<p>(4) An ERS EVC can include up to three service classes (ERS-B, ERS-PD and ERS-RT) as described above within each EVC. The customer will be required to identify the Basic, PD and RT Class of Service Ethernet frames by one of the following choices: setting the VLAN Class of Service (CoS) ID (for 802.1q tagged Ethernet Frames), or setting the DiffServ Code Point (DSCP) (for tagged or untagged Ethernet frames) or setting the VLAN ID (for tagged or untagged Ethernet frames), appropriately.</p>	

**XVIII. ADVANCED COMMUNICATIONS NETWORKS** (Continued)

<p>3. <i>Conditions</i></p> <p>a. A TLS network will be limited to central offices in a specific geographic location. Customers gain access to the shared TLS network via a switch, node or other Telephone Company equipment delivering service through a shared fiber path or network infra-structure deployed in the Customer’s serving central office (TLS equipped central office) or deployed in leased space near the Customer’s location or deployed at the Customer’s location. At subscription, the Customer has an option of selecting access lines at speeds of 10 Mbps, 100 Mbps, 1000 Mbps or 10 Gbps. The 10 Gbps UNI speed is only available through the Ethernet Relay Service (ERS) Premier Access line service type.</p>	
<p>b. TLS is available to Customers whose serving central office is a TLS equipped central office and is located within the maximum allowable range of the serving central office. The maximum allowable fiber range is determined by the dB loss rate where the actual distance between the TLS equipped serving wire center and the Customer’s location will vary based on the specifics of the transport facility used in each serving arrangement.</p>	
<p>c. If the Customer’s serving central office is not a TLS equipped central office, the Customer may obtain service by paying the Interoffice Mileage charge (from the customer’s serving central office and the nearest TLS equipped central office) in addition to TLS access charges. The fiber dB loss cannot exceed the maximum allowable range, as specified in regulation above.</p>	
<p>d. Provision of Service</p> <p>The TLS service will consist of:</p> <p>(1) Network Interface Device (NID) at the Customer’s premises to terminate the fiber pair or other optical transport.</p>	
<p>(2) Optical Transport from the Customer’s premises to the serving central office.</p>	
<p>(3) Network Management including fault monitoring and diagnostics, performance and network configuration applications and manual monitoring when necessary.</p>	
<p>(4) User Network Interface (UNI) Port with Access Line Connection</p> <p>UNI Port with Access Line Connections, provide connectivity between the customer premises and the serving wire center. UNI Port with Access Line connections can be purchased as either Standard, Protected, or Premier.</p>	
<p>For EMS service type, the customer may select a Standard Access or Protected Access Line Connection. The available UNI Port with Access Connections is 10 Mbps, 100Mbps, 100Mbps, 1000Mbps or 10 Gbps.</p>	
<p>For ERS service type, the customer must select a Standard Access or Premier Access Line Connection. The Standard Access Line Connection only supports ERS Standard EVCs. Premier Access Line Connections support ERS Basic Priority Data and Real-Time EVCs.</p>	

**XVIII. ADVANCED COMMUNICATIONS NETWORKS** (Continued)

<p>(5) Ethernet TLS Ethernet Virtual Circuit (EVC), where applicable.</p> <p>An Ethernet TLS EVC provides point-to-point Ethernet connectivity between two (2) UNIs, or between a UNI and a shared network EVC. Ethernet TLS EVCs are only available with ERS. The ERS Ethernet TLS EVCs are designed for customer applications that do require bandwidth or delay guarantees. ERS Standard provides no performance guarantees.</p>	
<p>(6) Interoffice Mileage, where applicable.</p>	
<p>(7) Optional Features</p> <p>Customer Service Management (CSM) is an optional feature that provides customers with web-based reports. These reports give the customer the ability to extract 'read-only' network traffic information regarding their networks thereby allowing customers to monitor and manage their network performance. CSM is provided per customer Domain/VLAN. CSM will be provided where conditions and facilities permit. The company reserves the right to temporarily interrupt CSM for maintenance, software upgrades, and in emergency situations.</p>	
<p>e. Availability of Service</p> <p>TLS is available where facilities and conditions permit. Special Construction charges may apply. TLS will be provided seven (7) days a week, twenty-four (24) hours a day, from central offices equipped to provide this service, with the exception noted.</p>	
<p>f. Maintenance Window</p> <p>To meet the Customers' requirements, occasional network upgrades must be performed. Network upgrades are needed to provide improved performance and new features. Generally network upgrades will be performed between the hours of 11 PM and 6 AM. Network upgrades are planned to provide customers reasonable and timely notification in order to minimize any impact on the customers' service.</p>	
<p>g. Connections</p> <p>The network interface is the LAN interface on the TLS equipment at the customer's premises. The customer is responsible for any inside wire required in connecting the LAN to the TLS equipment.</p>	
<p>The customer is also responsible for installation, operation and maintenance of any customer-provided equipment.</p>	
<p>The Company has the service responsibility up to and including the network interface.</p>	

**XVIII. ADVANCED COMMUNICATIONS NETWORKS** (Continued)

<p>The standard Customer connectivity model for UNI Port and Access includes direct fiber or existing fiber or existing transport facilities between the Customer's location and the TLS equipped central office. Customers requesting Protected Access Line service will have two standby fibers provisioned in addition to the primary direct fiber. Customer may select to have their UNI Port and Access provisioned over an optical transport system. If so, the customer must choose one of the following UNI Port with Access arrangements:</p> <ul style="list-style-type: none"> <li>- Protected Non-Diverse: Customer connectivity is provisioned over an optical transport system as a survivable service with an alternate (non-diverse) facility between the Customer's location and the TLS equipped central office. The optical protected interoffice charge is applicable to the 1000 Mbps speed when interoffice facilities are required.</li> </ul>	
<ul style="list-style-type: none"> <li>- Protected Diverse: Customer connectivity is provisioned over an optical transport system as a survival service with an alternate and diverse fiber path between the Customer's location and the TLS equipped central office. The optical protected interoffice charge is applicable to the 1000 Mbps speed when interoffice facilities are required. Dual entrance at the customer premises and company wire centers are not considered a standard feature of this option, but may be provided through special construction charges, where facilities are available.</li> </ul>	
<ul style="list-style-type: none"> <li>- Protected Private: Customer connectivity is provisioned over a dedicated private ring, which the customer has already obtained from the Telephone Company. At least one node of the private ring must be located in a TLS equipped central office.</li> </ul>	
<p>h. Limitations</p> <p>The customer's location must be within the allowable range of the TLS equipped central office, as defined in 3.b..</p>	
<p>i. Technical Specifications</p> <p>The technical standards for TLS are delineated by the Institute of Electrical and Electronic Engineers standards for Ethernet connectivity.</p>	
<p>j. Transmission Mode</p> <p>The transmission mode supported is dependent on the access rate. The supported transmission mode for 10 Mbps access is half-duplex and full duplex. Full duplex 10 Mbps access is available only where conditions and facilities permit. The supported transmission mode for 100 Mbps, 1000 Mbps, or 10 Gbps access is full duplex.</p>	
<p>4. <i>Service Level Agreements (SLA)</i></p> <p>Service Level Agreements (SLA) provide TLS Customers with Service Response Credits (SRC) applied to their Company-issued telephone bill if the Company fails to meet certain operational and network thresholds. SLAs are available at no additional charge or fee to the Customer.</p>	

**XVIII. ADVANCED COMMUNICATIONS NETWORKS** (Continued)

<p>A Customer is eligible for the SLA SRC given the Customer adheres to the conditions stated within this section. The SLA specifies performance criteria against which actual performance for TLS will be compared on a monthly basis.</p>	
<p>The TLS SLA includes the following measurements:</p> <p>Operational SLAs</p> <ul style="list-style-type: none"> <li>- Mean Time to Repair (MTTR)</li> <li>- Network Availability</li> <li>- All other EVCs do not qualify for Network Performance SLAs.</li> </ul>	
<p>Network Performance SLAs</p> <ul style="list-style-type: none"> <li>- Ethernet Virtual Circuit (EVC) Class of Service (CoS) Performance             <ul style="list-style-type: none"> <li>- Data Delivery Ratio (DDR)</li> <li>- Round Trip Delay (RTD)</li> <li>- Jitter</li> </ul> </li> </ul>	
<p>The SLA SRC will apply to the following TLS elements:</p> <p>UNI Port with Access Line Connection Ethernet Virtual Circuit (EVC) Bandwidth</p>	
<p>To receive SRCs on eligible rate elements, the Customer must have the eligible rate elements listed in its initial subscription based on the established customer of record, or have ordered the eligible rate elements subsequent to its initial subscription. The Company reserves the right to change, alter or discontinue the optional SRC plan at its discretion.</p>	
<p>All service performance and provisioning measurements are conducted using the Company monitoring systems and procedures. The Company may change these systems and procedures at its sole discretion. In performing measurements of overall Mean Time To Repair (MTTR) and Network Availability, the Company shall include data measured throughout the territories covered by this tariff.</p>	



**XVIII. ADVANCED COMMUNICATIONS NETWORKS** (Continued)

<p>To receive credit, the Company must receive from the Customer a written request for credit within thirty (30) calendar days of the end of the monitoring period that the SRC is referencing. The Customer's request for credit must be submitted to the appropriate Company entity (office or interface) in a manner prescribed by Company. The request must include a list of all impacted circuit/connection identification numbers and the type of SRC requested for each circuit/connection. The SRC monitoring period is based on a calendar month.</p> <p>a. Operational Service Level Agreement (SLAs)</p> <p>(1) Mean Time to Repair (MTTR)</p> <p>MTTR is the average mean time for the Company to repair Customer reported interruptions for service that is within the Company's network. A TLS service is interrupted when it becomes unusable to the Customer because of a failure of a facility component within the Company's network that is used to furnish service under this tariff.</p> <p>(a) MTTR Measurement</p> <p>Under the MTTR SLA, the Company will measure the average Time to Repair (TTR) for Customer-reported interruptions in the services with respect to TLS Access Lines. To be measured under this SLA, the Customer must report any interruption to a Company-designated entity for the opening of a trouble ticket. The TTR is measured from the date and time a trouble ticket is opened by the Company and the date and time when such ticket is closed by the Company. In measuring the TTR, any stop clock time or adjusted duration time associated with the trouble shall be subtracted from such measurement. For purposes of this measurement, stop clock time refers to</p>	
<p>(i) periods when the Customer testing is occurring;</p>	
<p>(ii) periods when the Company is awaiting the Customers authorization to commence work on a TLS Access Line;</p>	
<p>(iii) periods when the Company is denied access to the Customers premises or facilities as necessary to diagnose, repair or test</p>	
<p>(iv) periods following a repair of a TLS Access line when the ticket is held open by the Customer to ensure the trouble is resolved and</p>	
<p>(v) any time period during which any of the listed occurrences existed, as set forth in Section 4.d. SLA Exclusions following.</p>	
<p>The SLA shall not apply to cases of trouble where no trouble was found or repeated cases of trouble for the same interruption. The MTTR SLA shall be measured on a calendar month basis and shall be calculated by adding the TTR for all interruptions and dividing that sum by the total number of trouble tickets opened for interruptions for the Customer during that month.</p>	

**XVIII. ADVANCED COMMUNICATIONS NETWORKS** (Continued)

<p>(b) MTTR SRCs</p> <p>If the MTTR is greater than four (4) hours over the calendar month, then fifty percent (50%) of the one month TLS Access Line monthly charge shall be given as a MTTR SRC for those Access Lines which have been out of service for longer than four (4) hours and have been reported by the Customer via a trouble ticket to the Company. The MTTR SRC credit excludes and is not applicable to scheduled maintenance, scheduled downtimes or delays resulting from an event of force majeure.</p>	
<p>(2) Network Availability</p> <p>Network Availability refers to the percentage of time during a calendar month that the TLS is available for use by the Customer.</p> <p>(a) Network Availability Measurement</p> <p>The Company threshold for Network Availability is 99.90%. Network Availability is calculated on a per TLS Port Connection basis as follows:</p> <p><math display="block">\frac{((24 \times \text{Number of Days in Month} \times \text{Number of TLS Port Connections}) - (\text{Number of Hours Out of Service during Month}))}{(24 \times \text{Number of Days in Month} \times \text{Number of TLS Port Connections})}</math></p> <p>The Company will not round up the calculation to reach the 99.90% threshold. This SLA is only available for outages reported by the Customer via a trouble ticket to the Company.</p>	
<p>(b) Network Availability SRCs</p> <p>If the overall Network Availability measurement is less than the threshold of 99.90% for a calendar month, the Company will provide a credit equal to ten percent (10%) of the associated monthly charge for an individual TLS port connection that did not meet such threshold during such a calendar month.</p>	
<p>b. Network Performance SLAs</p> <p>Network Performance SLA applies to all Customers subscribing to an EVC Class of Service (CoS) within a local network consisting of the following types:</p> <ul style="list-style-type: none"> <li>- Real Time EVC bandwidth CoS, and</li> <li>- Priority Data EVC bandwidth CoS.</li> </ul>	

**XVIII. ADVANCED COMMUNICATIONS NETWORKS** (Continued)

<p>The performance SLA is hierarchical in nature and statistically-based, conformance is determined on a Met or Missed basis, first on a per-hour basis and then on a per-month conformance basis.</p> <ul style="list-style-type: none"> <li>- Per-Hour Conformance</li> </ul> <p>For each hour in the month, a determination is made as to whether the performance objectives are 'Met' for the CoS attributes related to the CoS instance on a given EVC. For a given Hour (e.g., H1), the overall performance objective is 'Met' if the performance objectives for each of the Data Delivery Ratio (DDR), Round Trip Delay (RTD), and Jitter, attributes are 'Met'. If any of the attribute objectives are 'Missed', then the overall performance objective for Hour (H1) is determined to be 'Missed'.</p>	
<ul style="list-style-type: none"> <li>- Per-Month Conformance</li> </ul> <p>For the month, a determination is made as to the percentage of hours that the overall performance objective is 'Met'. So, for a given Month (e.g., M1), the monthly performance guarantee is 'Met' if the % of hours 'Met' for the month meet or exceed the monthly objective.</p>	
<p>EVC Class of Service Network Performance SLA shall be based on the following Ethernet frame traffic criteria:</p> <p>(1) Data Delivery Ratio (DDR)</p> <p>DDR is defined as the ratio of service frames successfully received from the network relative to the number of service frames offered to the network. The DDR definition is restricted to service frames that are compliant to the subscribed Committed Information Rate (CIR) profile. Interruptions caused by MTTR activity shall be excluded from the measurement of DDR.</p> <p>(a) Real Time EVC Bandwidth – Data Delivery Ratio</p> <p>The Company threshold for Data Delivery Ratio is 99.5% in a calendar month.</p>	
<p>(b) Real Time EVC Bandwidth - Data Delivery SRCs</p> <p>If the overall Data Delivery measurement does not meet the per month conformance then the Company shall provide an SRC equal to ten percent (10%) of the monthly charge for any individual EVC that did not meet such threshold during such calendar month.</p>	
<p>(c) Priority Data EVC Bandwidth - Data Delivery Ratio</p> <p>The Company threshold for Data Delivery Ratio is ninety-nine percent (99%) in a calendar month.</p>	

**XVIII. ADVANCED COMMUNICATIONS NETWORKS** (Continued)

<p>(d) Priority Data EVC Bandwidth - Data Delivery SRCs</p> <p>If the overall Data Delivery measurement does not meet the per month conformance then the Company shall provide an SRC equal to ten percent (10%) of the monthly charge for any individual EVC that did not meet such threshold during such calendar month.</p>	
<p>(2) Round Trip Delay (RTD)</p> <p>RTD is defined as the time (in milliseconds) it takes for a service frame to be sent from one UNI to another UNI and back again (includes link insertion delays, propagation delays and queuing delays in the network). The RTD calculation includes only the time the packet is in the network, i.e., the processing time spent in devices attached to the UNI are factored out of the definition. The RTD definition is restricted to service frames that are compliant to the subscribed CIR profile.</p> <p>(a) Real Time EVC Bandwidth - Delay Measurement</p> <p>The Company threshold for Delay is twenty (20) milliseconds.</p>	
<p>(b) Real Time EVC Bandwidth - Delay SRCs</p> <p>If the overall delay measurement does not meet the per month conformance then the Company shall provide an SRC equal to ten percent (10%) of the monthly charge for any individual EVC that did not meet such threshold during such calendar month.</p>	
<p>(c) Priority Data EVC Bandwidth - Delay Measurement</p> <p>The Company threshold for Delay is fifty (50) milliseconds.</p>	
<p>(d) Priority Data EVC Bandwidth - Delay SRCs</p> <p>If the overall delay measurement does not meet the per month conformance then the Company shall provide an SRC equal to ten percent (10%) of the monthly charge for any individual EVC that did not meet such threshold during such calendar month.</p>	
<p>(3) Jitter</p> <p>Jitter is defined as the variance in frame delay (in milliseconds) between two service frames as measured at the ingress and egress UNIs. The jitter definition is restricted service frames that are compliant to the subscribed CIR profile.</p> <p>(a) Real Time EVC Bandwidth - Jitter Measurement</p> <p>The Company threshold for Delay is five (5) milliseconds.</p>	

**XVIII. ADVANCED COMMUNICATIONS NETWORKS** (Continued)

<p>(b) Real Time EVC Bandwidth - Jitter SRC</p> <p>If the overall jitter measurement does not meet the per month conformance then the Company shall provide an SRC equal to ten percent (10%) of the monthly charge for any individual EVC that did not meet such threshold during such calendar month.</p>	
<p>c. Validation for Operational and Network Performance SLAs</p> <p>(1) Customer Validation</p> <p>(a) Operational SLAs:</p> <p>The Customer must submit in writing a list of all rate elements, impacted circuit/connection identification numbers and the type of SRC requested for each circuit/connection. The written request for credit must be submitted to the appropriate Company entity in the manner prescribed by the Company.</p>	
<p>(b) Network Performance SLAs:</p> <p>The Customer must request SRCs for Network Performance SLAs and may submit in support of such request its own measurements made by industry-standard network performance measuring equipment. Such equipment shall be subject to prior approval by the Company and be capable of the following:</p> <p>(i) For the DDR SLA</p> <p>The equipment must be capable of determining the number of actual packets sent and successfully received between two (2) Customer locations.</p>	
<p>(ii) For the RTD SLA</p> <p>The equipment must be capable of measuring the transmission of a series of 128-byte time-stamped packets to a measurement system from one Customer location to another Customer location. The measurement systems must be time-synchronized by using a network based timing source that uses Greenwich Mean Time (GMT).</p>	
<p>(iii) For the Jitter SLA</p> <p>The equipment must be capable of measuring the transmission of a series of at least fifty (50), 128-byte time stamped packets at a fixed interval between each packet from one Customer location to a measurement system at another Customer location. The measurement systems must be time-synchronized by using a network based timing source that uses Greenwich Mean Time (GMT).</p>	

**XVIII. ADVANCED COMMUNICATIONS NETWORKS** (Continued)

<p>(2) Company Validation</p> <p>All equipment must be capable of measuring from edge to edge (Customer Premises Equipment (CPE) to CPE) and to make the measurement every five (5) minutes per hour for four (4) hours total per day, for a total of two-hundred forty (240) measures per day. In order to be considered, such measurements must include at least seven (7) consecutive days' worth of measurements for four (4) hours per day.</p>	
<p>d. SLA Exclusions</p> <p>SLAs do not apply to the extent that any of the following reasons prevented the Company from meeting such SLAs:</p> <p>(1) The acts of the Customer or other party authorized by the Customer to use the TLS circuit/connection, including but not limited to Customer's negligence, Customer's refusal to grant the Company reasonable access to its premises for testing/repair, Customer's refusal to release the TLS circuit/connection for testing and/or repair, Customer's maintenance activities or its rearrangement of the TLS circuit/connection or where the Customer has exceeded the purchased EVC bandwidth;</p>	
<p>(2) Subsequent reports (i.e., additional Customer inquiries) while the trouble is pending;</p>	
<p>(3) Service troubles closed due to the Customer's action;</p>	
<p>(4) Service troubles repaired by the Company prior to its receipt of a trouble report;</p>	
<p>(5) Service trouble caused by the Customer's CPE or facilities on its side of the demarcation point or any power, equipment, service or systems not provided by the Company;</p>	
<p>(6) An Interruption related to the provisioning of a new TLS Access Line or Access Lines in service for less than a month;</p>	
<p>(7) Scheduled maintenance and downtimes;</p>	
<p>(8) Unavailability of network monitoring or management equipment or reporting;</p>	
<p>(9) Any other reason outside the control of the Company.</p>	
<p>e. Limitation on SRCs</p> <p>The combined total of an SRCs applied to the Customer's TLS service for a calendar month must meet the following conditions:</p> <p>(1) For any calendar year, the total SRCs shall not exceed ten percent (10%) of the total annual revenue of the prior calendar year billed to the Customer for qualifying service elements, or two hundred thousand dollars (\$200,000) per Customer, whichever is less. For any calendar year in which the Customer had less than twelve (12) full months of revenue for qualifying service elements in the prior calendar year, the SRCs may not exceed twenty thousand dollars (\$20,000) per Customer for TLS Network.</p>	

## XVIII. ADVANCED COMMUNICATIONS NETWORKS (Continued)

<p>(2) To receive an SRC, the Customer must request such SRC in writing within thirty (30) calendar days of the end of the monitoring period of the referenced SRC. The request must include a list of all impacted EVC identification numbers and the type of SRC requested for each EVC.</p>	
<p>5. <i>Application of Rates and Charges</i></p> <p>a. The following rate elements are applicable to TLS:</p> <ul style="list-style-type: none"><li>- UNI Port with Access Line Connection<ul style="list-style-type: none"><li>- Standard Access Line</li><li>- Protected Access Line</li><li>- Premier Access Line</li><li>- EMS</li></ul></li><li>- Ethernet Virtual Circuit (EVC)</li><li>- Interoffice Mileage</li><li>- Domain/LAN Extension Equipment Changes</li><li>- Optional Features<ul style="list-style-type: none"><li>- Customer Service Management (CSM)</li></ul></li></ul> <p>(1) UNI Port and Access Line</p> <p>A monthly rate applies on a per line basis, based on the speed of the access connection (i.e. 10 Mbps, 100 Mbps, or 1000 Mbps). The Access Line is offered on a month to month basis, or as a three (3) year or five (5) year Term Payment Plan. A nonrecurring charge applies to the installation of the UNI Port with Access Line provided on a month-to-month basis.</p> <p>(a) Standard Access line (available for EMS Standard Service Type Only)</p> <p>A monthly rate applies on a per line basis, based on the speed of the access connection (i.e., 10 Mbps, 100 Mbps, or 1000 Mbps). The Standard Access Line is offered on a month-to-month basis for a minimum of nine (9) months, or as a three (3) year or five (5) year Term Commitment Plan. A nonrecurring charge will apply to the installation of a TLS Standard Access Line provided on a month-to-month basis. Besides the standard connectivity model, Standard Access Line is offered with three (3) other types of UNI Port with Access Line Connections, wither facilities exist.</p> <ul style="list-style-type: none"><li>(i) Protected No-Diverse</li><li>(ii) Protected Diverse</li><li>(iii) Protected Private</li></ul>	

**XVIII. ADVANCED COMMUNICATIONS NETWORKS** (Continued)

<p>(b) Protected Access Line (available for EMS Service Type Only)</p> <p>Protected Access Lines are provisioned as a survivable service with an alternate fiber pair between the central office and the customer premises. Protected Access Line allows the Company to detect and recover a failure and move the customer's data to an alternate fiber pair in less than one second. Both fiber pairs must be served by the same central office and must have the same access speed. The second fiber pair will be routed over a diverse fiber path when possible. A monthly rate applies on a per line basis, based on the speed of the access connection (i.e., 100 Mbps and 1000 Mbps). A nonrecurring charge will apply to the installation of a Protected Access Line provided on a month-to-month basis. Protected Access Line is only offered with a direct fiber UNI Port with Access Line Connection, where facilities exist.</p>	
<p>(c) Premier Access Line</p> <p>A monthly rate applies on a per-line basis, based on the speed of the access line (i.e., 10 Mbps 100 Mbps, 1000 Mbps or 10 Gbps). A Premier Access Line must be purchased in conjunction with some combination of ERS-B, ERS-PD, and/or ERS-RT EVC service classes, which are described in section B.1. The Premier Access Line is offered on a month-to-month basis or as a three (3) year or five (5) year Term Plan. A nonrecurring charge applies to the installation of the UNI provided on a month-to-month basis. A customer cannot mix Premier UNI Ports with any other UNI port type.</p>	
<p>The percentage of each Premier Access Line UNIs allowed for EVC bandwidth is limited, where connections must comply with each of the following threshold requirements:</p> <ul style="list-style-type: none"> <li>ERS-B less than or = 500% of UNI Speed</li> <li>ERS-PD less than or = 85% of UNI Speed</li> <li>ERS-RT less than or = 50% of UNI Speed</li> <li>ERS-PD + ERS-RT less than or = 85% of UNI Speed</li> <li>ERS-B + ERS-PD + ERS-RT less than or = 500% of UNI Speed</li> </ul>	
<p>Besides the standard connectivity model, Premier Access Line is offered with three other types of UNI Port with Access Line Connections, where facilities exist.</p> <ul style="list-style-type: none"> <li>(i) Protected No-Diverse</li> <li>(ii) Protected Diverse</li> <li>(iii) Protected Private</li> </ul>	



**XVIII. ADVANCED COMMUNICATIONS NETWORKS** (Continued)

<p>(d) EMS Real Time (EMS-RT) Access Line</p> <p>A monthly rate applies on a per-line basis, based on the speed of the access connection (i.e., 100 MBPS or 1000 MBPS). This enhanced service class configures a fixed portion of the UNI to be configured for Real Time Traffic, where each 100 MBPS UNI has CIR = 5 MBPS with EIR = 0 with each 1000 MBPS UNI has CIR = 20 MBPS with EIR = 0. The remainder of the UNI can be used for CIR = 0 and EIR = 0 traffic. The EMS-RT Access Line is offered on a month-to-month basis or as a 3 Year or 5 Year Term Plan. A nonrecurring charge applies to the installation of the EMS-RT Access Line provided on a month-to-month basis. A customer cannot mix an EMS-RT Access Line with the ERS Service type, but may mix EMS-RT Access Line with EMS Access Lines. Besides the standard connectivity model, Premier Access Line is offered with three other types of UNI Port with Access Line Connections, where facilities exist.</p> <ul style="list-style-type: none"> <li>(i) Protected No-Diverse</li> <li>(ii) Protected Diverse</li> <li>(iii) Protected Private</li> </ul>	
<p>(2) Ethernet Virtual Circuit (EVC)</p> <p>For customers who order the Standard Access Line, a monthly rate will apply on a per EVC bandwidth basis. ERS Standard is the only EVC class available with the Standard Access Line. The EVC bandwidth must be equal to the bandwidth of the lowest speed of the end points it is connecting. ERS Standard EVCs are purchased on a month-to-month basis. A non-recurring setup charge will apply per ERS Standard EVC.</p>	
<p>For customers who order the Premier Access Line, a monthly rate will apply on a service class and EVC bandwidth basis. Premier Access Line customers have the choice of combining ERS-Basic, ERS-Priority Data, and/or ERS-Real Time bandwidth on an EVC. A non-recurring setup charge will apply per ERS EVC. EVCs are purchased on a month-to-month basis. A customer may have more than one service class on the EVC, but will only pay one EVC non-recurring setup charge.</p>	
<p>The number of EVCs permitted on each Standard Access Line and/or Premier Access Line are limited as follows:</p> <ul style="list-style-type: none"> <li>10 Mbps less than or = 2 EVCs</li> <li>100 Mbps less than or = 16 EVCs</li> <li>1000 Mbps less than or = 75 EVCs</li> <li>10 Gbps less than or = 250 EVCs</li> </ul>	

**XVIII. ADVANCED COMMUNICATIONS NETWORKS** (Continued)

<p>ERS-Basic, ERS-Priority Data and ERS-Real Time EVC bandwidth is limited to a maximum Mbps per Service Class per EVC, and must comply with each of the following maximum limits:</p>			
<u>EVC Service Class</u>	100 Mbps UNI <u>Max/EVC</u>	1000 Mbps UNI <u>Max/EVC</u>	10 Gbps UNI <u>MAX/EVC</u>
ERS-B	100 Mbps	1000 Mbps	1000 Mbps
ERS-PD	50 Mbps	500 Mbps	500 Mbps
ERS-RT	50 Mbps	500 Mbps	100 Mbps
<p>(3) Interoffice Mileage</p> <p>The Interoffice Mileage charge is based on the Per Mile charge multiplied by the distance in airline miles between the customer's serving central office and the nearest TLS equipped central office. An equipped central office refers to a central office equipped with a switch node or other Telephone Company equipment capable of delivering service via shared fiber path or network infrastructure. This interoffice distance is measured in airline miles and charged in one-mile increments, based upon latitude and longitude of each central office. The mileage measurement is calculated as specified by the FCC NECA Tariff. This monthly charge will apply in addition to the applicable rates and charges for Standard Access Line, Protected Access Line or Premier Access Line. The protected transport option for 10/100Mbps, Protected Non-Diverse and Protected Diverse, UNI speeds includes optical protected interoffice transport when needed.</p>			
<p>(4) Domain/LAN Extension Equipment Changes</p> <p>Customer requests for changes in Domains and replacement of LAN extension equipment will be charged a nonrecurring charge per location per change.</p>			
<p>(5) Optional Features</p> <p>(a) Customer Service Management (CSM)</p> <p>A monthly rate and a nonrecurring charge apply for each CSM arrangement. The customer will be charged on a per Domain/VLAN basis. The nonrecurring charge applies in addition to all other applicable service charges.</p>			
<p>(b) Minimum Period</p> <p>The minimum period for TLS under the month-to-month plan is nine (9) months.</p>			
<p>(c) Term Commitment Plans</p> <p>The TLS Standard, Protected and Premier Access Line is offered under a three (3) or five (5) year Term Commitment Plan. The regulations applicable to TLS provided under a Term Commitment Plan are specified in 4.e.</p>			

**XVIII. ADVANCED COMMUNICATIONS NETWORKS** (Continued)

<p>(d) Moves, Changes and Upgrades</p> <p>When Customer requests a move or relocation of a Standard Access Line, Protected Access Line, Premier Access Line or EMS Real Time Access Line to a different address and/or building, the move or relocation will be treated as a termination of the existing service and the establishment of a new service for the application of all charges.</p>	
<p>When the Customer requests an upgrade in service speed, or change in service type, at an existing address, the upgrade in service speed/change in service type will be treated as a termination of the existing service and the establishment of a new service for the application of all charges.</p>	
<p>Customer requests for changes in Domains and replacement of LAN extension equipment will be charged a nonrecurring charge per location per change.</p>	
<p>(e) Termination Liability</p> <p>In the event TLS is terminated by the Customer prior to completion of the current term commitment period, the Customer shall be liable for an early termination charge, except as noted below. The amount of the early termination charge will be twenty-five percent (25%) of the monthly recurring charge(s) (MRC) for the remainder of the term.</p>	
<p>Early termination charges will apply only to those rate elements under a term commitment period. If tariff rates for the service are increased during the term period, exclusive of any increase due to local, state or federal fees, taxes or surcharges, the Customer may terminate the service without incurring an early termination charge.</p>	
<p>Prior to the end of the term commitment period, the Customer may select one of the following options, to be effective at the end of the term:</p> <p>Renew term commitment, Commit to a new term period, Arrange for a change of service, or Arrange for termination of the service</p>	
<p>In the event the Customer does not select one of the above options, the Customer will be converted to the shortest-term period available under tariff (i.e., month-to-month, etc.) for the same service, and will be subject to the applicable term commitment, if any, unless the Customer terminates the service within sixty (60) days of the conversion date. Early termination charges will not be assessed under the following circumstances:</p> <ul style="list-style-type: none"> <li>- Customer moves existing service either to a new location within the same address and/or same building (inside move) or to a new location (outside move) and maintains that service for the remainder of the term;</li> </ul>	
<ul style="list-style-type: none"> <li>- Customer attempts to move the existing service to a new location within the Company's service area, but the service is unavailable;</li> </ul>	

**XVIII. ADVANCED COMMUNICATIONS NETWORKS** (Continued)

<ul style="list-style-type: none"> <li>- Customer renegotiates a new term commitment plan for the same service before the current term commitment expires and the value of the new term commitment is equal to or greater than the remaining value of the current term commitment; or</li> </ul>																																																											
<ul style="list-style-type: none"> <li>- Customer changes to another service or upgrades service to a higher speed or capacity under a term commitment, provided the following conditions are met:               <ul style="list-style-type: none"> <li>- The value of the new term commitment is equal to or greater than the remaining value of the current term commitment,</li> </ul> </li> </ul>																																																											
<ul style="list-style-type: none"> <li>- The Company provides the new service via tariff or on an individual case basis (ICB), and</li> </ul>																																																											
<ul style="list-style-type: none"> <li>- The order to discontinue the existing service and the order for the new or upgraded service are received by the Company at the same time.</li> </ul>																																																											
<p><b>6. Rates and Charges</b></p> <p style="margin-left: 20px;">a. TSL Standard Access Line, per line</p> <p style="margin-left: 40px;">(1) UNI Port with Access Line</p> <table style="margin-left: 60px; border-collapse: collapse; width: 80%;"> <thead> <tr> <th style="text-align: left;"></th> <th style="text-align: center;"><u>Monthly Rate</u></th> <th style="text-align: center;"><u>Nonrecurring Charge</u></th> </tr> </thead> <tbody> <tr> <td colspan="3" style="padding-top: 10px;">Month to Month Plan</td> </tr> <tr> <td style="padding-left: 20px;">10 Mbps</td> <td></td> <td></td> </tr> <tr> <td style="padding-left: 40px;">Half duplex</td> <td style="text-align: right;">\$1,200.00</td> <td style="text-align: right;">\$1,300.00</td> </tr> <tr> <td style="padding-left: 40px;">Full duplex</td> <td style="text-align: right;">1,200.00</td> <td style="text-align: right;">1,300.00</td> </tr> <tr> <td style="padding-left: 20px;">100 Mbps</td> <td style="text-align: right;">2,400.00</td> <td style="text-align: right;">1,300.00</td> </tr> <tr> <td style="padding-left: 20px;">1000 Mbps</td> <td style="text-align: right;">4,000.00</td> <td style="text-align: right;">1,300.00</td> </tr> <tr> <td colspan="3" style="padding-top: 10px;">Three Year Plan</td> </tr> <tr> <td style="padding-left: 20px;">10 Mbps</td> <td></td> <td></td> </tr> <tr> <td style="padding-left: 40px;">Half duplex</td> <td style="text-align: right;">1,000.00</td> <td style="text-align: center;">N/A</td> </tr> <tr> <td style="padding-left: 40px;">Full duplex</td> <td style="text-align: right;">1,000.00</td> <td style="text-align: center;">N/A</td> </tr> <tr> <td style="padding-left: 20px;">100 Mbps</td> <td style="text-align: right;">2,000.00</td> <td style="text-align: center;">N/A</td> </tr> <tr> <td style="padding-left: 20px;">1000 Mbps</td> <td style="text-align: right;">3,500.00</td> <td style="text-align: center;">N/A</td> </tr> <tr> <td colspan="3" style="padding-top: 10px;">Five Year Plan</td> </tr> <tr> <td style="padding-left: 20px;">10 Mbps</td> <td></td> <td></td> </tr> <tr> <td style="padding-left: 40px;">Half duplex</td> <td style="text-align: right;">900.00</td> <td style="text-align: center;">N/A</td> </tr> <tr> <td style="padding-left: 40px;">Full duplex</td> <td style="text-align: right;">900.00</td> <td style="text-align: center;">N/A</td> </tr> <tr> <td style="padding-left: 20px;">100 Mbps</td> <td style="text-align: right;">1,800.00</td> <td style="text-align: center;">N/A</td> </tr> <tr> <td style="padding-left: 20px;">1000 Mbps</td> <td style="text-align: right;">3,200.00</td> <td style="text-align: center;">N/A</td> </tr> </tbody> </table>			<u>Monthly Rate</u>	<u>Nonrecurring Charge</u>	Month to Month Plan			10 Mbps			Half duplex	\$1,200.00	\$1,300.00	Full duplex	1,200.00	1,300.00	100 Mbps	2,400.00	1,300.00	1000 Mbps	4,000.00	1,300.00	Three Year Plan			10 Mbps			Half duplex	1,000.00	N/A	Full duplex	1,000.00	N/A	100 Mbps	2,000.00	N/A	1000 Mbps	3,500.00	N/A	Five Year Plan			10 Mbps			Half duplex	900.00	N/A	Full duplex	900.00	N/A	100 Mbps	1,800.00	N/A	1000 Mbps	3,200.00	N/A	
	<u>Monthly Rate</u>	<u>Nonrecurring Charge</u>																																																									
Month to Month Plan																																																											
10 Mbps																																																											
Half duplex	\$1,200.00	\$1,300.00																																																									
Full duplex	1,200.00	1,300.00																																																									
100 Mbps	2,400.00	1,300.00																																																									
1000 Mbps	4,000.00	1,300.00																																																									
Three Year Plan																																																											
10 Mbps																																																											
Half duplex	1,000.00	N/A																																																									
Full duplex	1,000.00	N/A																																																									
100 Mbps	2,000.00	N/A																																																									
1000 Mbps	3,500.00	N/A																																																									
Five Year Plan																																																											
10 Mbps																																																											
Half duplex	900.00	N/A																																																									
Full duplex	900.00	N/A																																																									
100 Mbps	1,800.00	N/A																																																									
1000 Mbps	3,200.00	N/A																																																									

**XVIII. ADVANCED COMMUNICATIONS NETWORKS** (Continued)

(2) UNI Port with Access Line – Protected Non-Diverse, per line		
	<u>Monthly Rate</u>	<u>Nonrecurring Charge</u>
Month to Month Plan		
10 Mbps	\$1,600.00	\$1,300.00
100 Mbps	2,600.00	1,300.00
1000 Mbps	9,000.00	1,300.00
Three Year Plan		
10 Mbps	1,400.00	N/A
100 Mbps	2,400.00	N/A
1000 Mbps	8,000.00	N/A
Five Year Plan		
10 Mbps	1,300.00	
100 Mbps	2,100.00	N/A
1000 Mbps	7,000.00	N/A
b. Protected Access Line, per line		
	<u>Monthly Rate</u>	<u>Nonrecurring Charge</u>
Month to Month Plan		
100 Mbps	\$3,600.00	\$1,300.00
1000 Mbps	6,000.00	1,300.00
Three Year Plan		
100 Mbps	3,000.00	N/A
1000 Mbps	5,200.00	N/A
Five Year Plan		
100 Mbps	2,700.00	N/A
1000 Mbps	4,800.00	N/A

**XVIII. ADVANCED COMMUNICATIONS NETWORKS** (Continued)

c. Premier Access Line		
UNI Port with Access Line, per Line:	Monthly <u>Rate</u>	Nonrecurring <u>Charge</u>
Month to Month Plan		
10 Mbps	\$1,075.00	\$1,300.00
100 Mbps	1,200.00	1,300.00
1000 Mbps	2,400.00	1,300.00
10 Gbps	10,500.00	1,300.00
Three Year Plan		
10 Mbps	875.00	N/A
100 Mbps	1,000.00	N/A
1000 Mbps	2,000.00	N/A
10 Gbps	9,000.00	N/A
Five Year Plan		
10 Mbps	775.00	
100 Mbps	900.00	N/A
1000 Mbps	1,800.00	N/A
10 Gbps	8,000.00	N/A
d. EMS – Real Time Access Line		
(1) UNI Port with Access Line, per line.	Monthly <u>Rate</u>	Nonrecurring <u>Charge</u>
Month to Month Plan		
100 Mbps	\$2,500.00	\$1,300.00
1000 Mbps	4,500.00	1,300.00
Three Year Plan		
100 Mbps	2,100.00	N/A
1000 Mbps	4,000.00	N/A
Five Year Plan		
100 Mbps	1,900.00	N/A
1000 Mbps	3,700.00	N/A

**XVIII. ADVANCED COMMUNICATIONS NETWORKS** (Continued)

(2) UNI Port with Access Line – Protected Non-Diverse, per line		
	<u>Monthly Rate</u>	<u>Nonrecurring Charge</u>
Month to Month Plan		
100 Mbps	\$2,700.00	\$1,300.00
1000 Mbps	11,000.00	1,300.00
Three Year Plan		
100 Mbps	2,500.00	N/A
1000 Mbps	10,000.00	N/A
Five Year Plan		
100 Mbps	2,300.00	N/A
1000 Mbps	9,000.00	N/A
(3) UNI Port with Access Line – Protected Diverse, per line		
	<u>Monthly Rate</u>	<u>Nonrecurring Charge</u>
Month to Month Plan		
100 Mbps	\$3,250.00	\$1,300.00
1000 Mbps	10,000.00	1,300.00
Three Year Plan		
100 Mbps	3,000.00	N/A
1000 Mbps	9,000.00	N/A
Five Year Plan		
100 Mbps	2,750.00	N/A
1000 Mbps	8,500.00	N/A

**XVIII. ADVANCED COMMUNICATIONS NETWORKS** (Continued)

(4) UNI Port with Access Line – Protected Private, per line		
	<u>Monthly Rate</u>	<u>Nonrecurring Charge</u>
Month to Month Plan		
100 Mbps	\$950.00	\$1,300.00
1000 Mbps	2,700.00	1,300.00
Three Year Plan		
100 Mbps	850.00	N/A
1000 Mbps	2,500.00	N/A
Five Year Plan		
100 Mbps	750.00	N/A
1000 Mbps	2,100.00	N/A
e. ERS Ethernet Virtual Circuit (EVC)		
	<u>Monthly Rate</u>	<u>Nonrecurring Charge</u>
ERS EVC Setup, per EVC	N/A	\$200.00
ERS EVC Standard (ERS-Std), per EVC		
10 Mbps	50.00	N/A
100 Mbps	100.00	N/A
1000 Mbps	200.00	N/A



**XVIII. ADVANCED COMMUNICATIONS NETWORKS** (Continued)

(1) ERS EVA Basic (ERS-B) Bandwidth, per Class	Monthly Rate	Nonrecurring Charge
1 Mbps	\$15.00	N/A
2 Mbps	30.00	N/A
3 Mbps	45.00	N/A
4 Mbps	60.00	N/A
5 Mbps	75.00	N/A
6 Mbps	90.00	N/A
7 Mbps	105.00	N/A
8 Mbps	120.00	N/A
9 Mbps	135.00	N/A
10 Mbps	150.00	N/A
20 Mbps	300.00	N/A
30 Mbps	450.00	N/A
40 Mbps	600.00	N/A
50 Mbps	750.00	N/A
60 Mbps	850.00	N/A
70 Mbps	950.00	N/A
80 Mbps	1,050.00	N/A
90 Mbps	1,150.00	N/A
100 Mbps	1,250.00	N/A
200 Mbps	1,350.00	N/A
300 Mbps	1,450.00	N/A
400 Mbps	1,550.00	N/A
500 Mbps	1,650.00	N/A
600 Mbps	1,740.00	N/A
700 Mbps	1,830.00	N/A
800 Mbps	1,920.00	N/A
900 Mbps	2,010.00	N/A
1,000 Mbps	2,100.00	N/A

**XVIII. ADVANCED COMMUNICATIONS NETWORKS** (Continued)

(2) ERS EVC Priority Data (ERS-PD) Bandwidth, per Class	Monthly Rate	Nonrecurring Charge
1 Mbps	\$40.00	N/A
2 Mbps	80.00	N/A
3 Mbps	120.00	N/A
4 Mbps	160.00	N/A
5 Mbps	200.00	N/A
6 Mbps	220.00	N/A
7 Mbps	240.00	N/A
8 Mbps	260.00	N/A
9 Mbps	280.00	N/A
10 Mbps	300.00	N/A
20 Mbps	600.00	N/A
30 Mbps	900.00	N/A
40 Mbps	1,200.00	N/A
50 Mbps	1,500.00	N/A
60 Mbps	1,720.00	N/A
70 Mbps	1,940.00	N/A
80 Mbps	2,100.00	N/A
90 Mbps	2,300.00	N/A
100 Mbps	2,500.00	N/A
200 Mbps	2,700.00	N/A
300 Mbps	2,900.00	N/A
400 Mbps	3,100.00	N/A
500 Mbps	3,300.00	N/A

**XVIII. ADVANCED COMMUNICATIONS NETWORKS** (Continued)

(3) ERS EVReal Time (ERS-RT) Bandwidth, per Class	Monthly <u>Rate</u>	Nonrecurring <u>Charge</u>
1 Mbps	\$120.00	N/A
2 Mbps	240.00	N/A
3 Mbps	360.00	N/A
4 Mbps	480.00	N/A
5 Mbps	600.00	N/A
6 Mbps	660.00	N/A
7 Mbps	720.00	N/A
8 Mbps	780.00	N/A
9 Mbps	840.00	N/A
10 Mbps	900.00	N/A
20 Mbps	1,175.00	N/A
30 Mbps	1,450.00	N/A
40 Mbps	1,725.00	N/A
50 Mbps	2,000.00	N/A
60 Mbps	2,200.00	N/A
70 Mbps	2,400.00	N/A
80 Mbps	2,600.00	N/A
90 Mbps	2,800.00	N/A
100 Mbps	3,000.00	N/A
f. Interoffice Mileage, per line	Monthly <u>Rate</u>	Nonrecurring <u>Charge</u>
Per Mile	\$100.00	N/A
Per Optical Protected Mile Protected Non-Diverse and Protected Diverse Only	750.00	N/A
g. TLS Domain/LAN Extension Equipment Changes	Monthly <u>Rate</u>	Nonrecurring <u>Charge</u>
Per Change	N/A	\$400.00

**XVIII. ADVANCED COMMUNICATIONS NETWORKS** (Continued)

h. Optional Features	Monthly Rate	Nonrecurring Charge
Customer Service Management (CSM) Per Domain/VLAN	\$150.00	\$350.00
i. TLS Standard Access Line, per line		
(1) UNI Port with Access Line – Protected Diverse, per line		
	Monthly Rate	Nonrecurring Charge
Month to Month Plan		
10 Mbps	\$1,900.00	\$1,300.00
100 Mbps	3,000.00	1,300.00
1000 Mbps	9,500.00	1,300.00
Three Year Plan		
10 Mbps	1,800.00	N/A
100 Mbps	2,800.00	N/A
1000 Mbps	8,500.00	N/A
Five Year Plan		
10 Mbps	1,700.00	N/A
100 Mbps	2,500.00	N/A
1000 Mbps	7,500.00	N/A
(2) UNI Port with Access Line – Protected Private, per line		
	Monthly Rate	Nonrecurring Charge
Month to Month Plan		
10 Mbps	\$700.00	\$1,300.00
100 Mbps	900.00	1,300.00
1000 Mbps	2,600.00	1,300.00
Three Year Plan		
10 Mbps	600.00	N/A
100 Mbps	800.00	N/A
1000 Mbps	2,400.00	N/A
Five Year Plan		
10 Mbps	500.00	N/A
100 Mbps	700.00	N/A
1000 Mbps	2,000.00	N/A

**XVIII. ADVANCED COMMUNICATIONS NETWORKS** (Continued)

j. Premier Access Line		
(1) UNI Port with Access Line – Protected Non-Diverse, per line		
	<u>Monthly Rate</u>	<u>Nonrecurring Charge</u>
Month to Month Plan		
10 Mbps	\$1,050.00	\$1,300.00
100 Mbps	1,900.00	1,300.00
1000 Mbps	7,500.00	1,300.00
Three Year Plan		
10 Mbps	900.00	N/A
100 Mbps	1,600.00	N/A
1000 Mbps	7,000.00	N/A
Five Year Plan		
10 Mbps	750.00	N/A
100 Mbps	1,450.00	N/A
1000 Mbps	6,500.00	N/A
(2) UNI Port with Access Line – Protected Diverse, per line		
	<u>Monthly Rate</u>	<u>Nonrecurring Charge</u>
Month to Month Plan		
10 Mbps	\$1,200.00	\$1,300.00
100 Mbps	2,150.00	1,300.00
1000 Mbps	9,000.00	1,300.00
Three Year Plan		
10 Mbps	1,000.00	N/A
100 Mbps	1,800.00	N/A
1000 Mbps	8,500.00	N/A
Five Year Plan		
10 Mbps	850.00	N/A
100 Mbps	1,600.00	N/A
1000 Mbps	8,000.00	N/A

**XVIII. ADVANCED COMMUNICATIONS NETWORKS** (Continued)

(3) UNI Port with Access Line – Protected Private, per line		
	<u>Monthly Rate</u>	<u>Nonrecurring Charge</u>
Month to Month Plan		
10 Mbps	\$600.00	\$1,300.00
100 Mbps	700.00	1,300.00
1000 Mbps	1,700.00	1,300.00
Three Year Plan		
10 Mbps	500.00	N/A
100 Mbps	600.00	N/A
1000 Mbps	1,550.00	N/A
Five Year Plan		
10 Mbps	400.00	N/A
100 Mbps	500.00	N/A
1000 Mbps	1,400.00	N/A

## XIX. EXPANDED INTERCONNECTION SERVICES

<p><b>A. <u>Service Description</u></b></p> <p>Expanded Interconnection Service (EIS) provides customers with the capability to terminate basic fiber optic transmission facilities, including optical terminating equipment and multiplexers at the Company wire centers and access tandems and interconnect those facilities with facilities of the Company. EIS will be provided in Company wire centers and access tandems listed in this section and in accordance with OAR 860-35-110 through OAR 860-35-130. EIS for special access is available in all end offices, serving wire centers, and remote nodes used as rating points for special access. EIS for switched access is available in these locations as well as any stand-alone tandem location.</p> <p>Additional information is available in the Company's Open Network Architecture (ONA) tariff.</p>	
<p><b>B. <u>Provision of EIS</u></b></p> <p><b>1. <i>General</i></b></p> <p>a. EIS will be provided as Virtual EIS where the interconnection with Company facilities occurs outside the wire center or access tandem in a manhole or other similar location.</p> <p>b. EIS arrangements are available for Switched Access and DS1 (1.544 Mbps) and DS3 (44.735 Mbps) Special Access transmission facilities and terminating equipment to Company wire center or access tandem facilities in or near Company buildings. Other types of arrangements will be addressed on an Individual Case Basis.</p> <p>c. EIS will be available for microwave transmission on a case by case basis where reasonably feasible. EIS provisioned with non-fiber optic facilities will be handled on an ICB when feasible.</p> <p>d. Customer provided facilities and equipment are subject to the terms, conditions, and rates specified in this tariff.</p> <p>e. The Company is not responsible for the design, engineering, or performance of customer's equipment, customer designated termination equipment and customer provided facilities for Virtual EIS.</p> <p>f. The Company is not required to purchase additional plant or equipment, to relinquish floor space or facilities designated for Company use, to undertake construction of new wire centers or access tandems, or to construct additions to existing wire centers or access tandems to satisfy a customer request.</p> <p>g. The expansion of the Company's enhanced services operation shall not take precedent over existing written requests for collocation.</p>	
<p><b>2. <i>Responsibility of the Company</i></b></p> <p>a. The Company will provide EIS, within the limitations of space and facilities.</p> <p>b. The emergency provisioning and restoration of interconnection service shall be in accordance with 47 CFR § 64.401 which specifies the priority for such activities.</p>	

**XIX. EXPANDED INTERCONNECTION SERVICES** (Continued)

<p>c. The Company will establish points of contact for the customer to place a request for EIS. The point of contact will provide the customer with a packet of general information, including an Application Form.</p>	
<p>d. The Company will provide at least two separate points of entry to the wire center or access tandem where there are two (2) entry points for the Company cable facilities, except in situations where one (1) entry of a two (2) entry office is filled to capacity.</p>	
<p>e. The Company will not purchase customer designated termination equipment from a vendor for the customer's use. If the customer chooses, the Company will assist the customer in the purchase of terminating equipment by establishing a contact point with the Company's Supply company.</p>	
<p><b>3. <i>Rights of the Company</i></b></p> <p>a. The Company retains ownership of wire center or access tandem floor space and equipment used to provide EIS.</p>	
<p>b. The Company reserves the right to refuse use of customer designated interconnection equipment which does not meet network reliability standards and fire and safety codes.</p>	
<p>c. The Company reserves for itself and its successors and assignees, the right to utilize the wire center(s) or access tandem(s) space in such a manner as will best enable it to fulfill Company's service requirements.</p>	
<p>d. The Company shall have the right, for good cause shown, and upon twelve (12) months' written notice, to reclaim any partitioned space, cable space or conduit space to fulfill its obligation under Public Service law and its tariffs to provide basic telecommunication services to its end user customers. In such cases, the Company will reimburse the customer for reasonable direct costs and expenses in connection with such reclamation.</p>	
<p><b>C. <u>Obligations of the Customer</u></b></p> <p><b>1. <i>Responsibility of the Customer</i></b></p> <p>a. The customer is responsible for coordinating with the Company to ensure that services are installed in accordance with the service request.</p>	
<p>b. The customer will be responsible for any additional costs incurred by the Company for installation or maintenance of customer designated transmission equipment. Installation or maintenance will not begin until agreed to by the customer.</p>	
<p>c. In the event of a Company work stoppage, the customer's employees, contractors or agents will comply with the emergency operation procedures established by the Company.</p>	
<p>d. The customer is responsible for payment of all charges as described in Section <i>III.D.</i>. Disputed bills will be subject to provisions in Section <i>III.D.</i>. Failure to make payment will result in disconnection of service in accordance with Section <i>III.A.8.</i>.</p>	



**XIX. EXPANDED INTERCONNECTION SERVICES** (Continued)

<p>e. The customer will be responsible to obtain appropriate insurance coverage, including but not limited to, fire, theft, and liability.</p>	
<p>f. The customer will be held liable for the actions and inactions of its employees, vendors, or contractors having access to Company wire center or access tandem equipment, manholes, property and facilities.</p>	
<p>g. The customer is responsible for the purchase and delivery of customer designated termination equipment to be installed in the Company wire center or access tandem for virtual EIS. The customer will sell the customer designated termination equipment to the Company for one dollar (\$1.00) at the time the equipment is delivered to the wire center or access tandem where it is to be installed. Upon termination of virtual EIS, the customer will purchase the customer designated termination equipment from the Company for one dollar (\$1.00).</p>	
<p><b>2. <i>Mechanic's or Materialmen's Liens</i></b></p> <p>The customer shall not permit any mechanic's or materialmen's liens caused by or resulting from any work performed, materials furnished or obligations incurred by or at the request of the customer to be placed upon the wire center or access tandem or any of the Company's property. In the case of the filing of any such lien, the customer shall immediately pay the lien in full.</p>	
<p>If default in the payment continues for ten (10) days after written notice from the Company to the customer, the Company will have the right, at the Company's option, of paying the lien or any portion of the lien, without inquiry as to the validity of the lien, and the customer shall reimburse the Company for any amounts paid, including expenses and interest, within ten (10) days after delivery to the customer of an invoice. Failure to remit payment to the Company within ten (10) days will result in disconnection of service as described in Section III.A.8.</p>	
<p><b>3. <i>Confidentiality</i></b></p> <p>The customer and the Company shall hold in confidence all information of a competitive nature between the two (2) parties.</p>	
<p><b>4. <i>Network Outage, Damage and Reporting</i></b></p> <p>a. The customer shall be responsible for any damage or network outage occurring as a result of termination of customer owned equipment in the Company wire center or access tandem.</p>	
<p>b. (Reserved for Future Use)</p>	
<p>c. The customer is responsible for providing a contact number that is readily accessible twenty-four (24) hours a day, seven (7) days a week.</p>	
<p>d. The customer shall be responsible for notifying the Company of significant outages which could impact or degrade the Company's switches and services and provide estimated clearing time for restoral.</p>	

**XIX. EXPANDED INTERCONNECTION SERVICES** (Continued)

<p><b>D. <u>Discontinuance of Service</u></b></p> <p>General:</p> <p>1. The Company will make every effort to contact the customer in the event the customer's equipment disrupts the network. If the Company is unable to make contact with the customer, the Company shall temporarily disconnect the customer's service as described in <i>III.B.2.b.</i></p>	
<p>2. The Company reserves the right to terminate EIS, in the event the customer is not in conformance with Company standards and requirements and/or in the event the customer imposes continued disruption and threat of harm to Company employees and/or network, or the Company's ability to provide service to other customers.</p>	
<p>3. Upon discontinuance of Virtual EIS service, the Company will disconnect and remove the customer designated termination equipment from the Company wire center or access tandem. The Company will work with the customer to coordinate return of the equipment to the customer.</p>	
<p><b>E. <u>Ordering Options for EIS</u></b></p> <p>1. <i>Virtual EIS Service</i></p> <p>a. Customers seeking virtual EIS shall submit an Application form and a \$2500 non-refundable fee for each wire center or access tandem which will be applied toward the Engineering/Installation Fee. The customer will be required to provide information such as, wire center or access tandem location, number and type of terminations, type of equipment, etc. The customer must provide all required information before the Company will begin work on the request.</p>	
<p>b. Upon receipt of the \$2500 fee, the Company will initiate a search of engineering records, an inspection of outside plant facilities, and other administrative activities required to process the request.</p>	
<p>c. Virtual EIS will be provided to customers at rates and charges, including the Engineering/Installation Fee, specific to the location and customer designated equipment installed.</p>	
<p>2. <i>Microwave Services</i></p> <p>EIS through microwave service will be provided, where reasonably feasible, only on a case-by-case basis. Rules, regulations and rates will be developed and filed upon a bona fide request from customers to provide microwave interconnection.</p>	
<p>3. <i>Data Over Voice (DOV) Equipment</i></p> <p>Data Over Voice (DOV) Equipment may be used within the interconnection arrangement for Special or Switched EIS. If the DOV equipment is an adjunct or stand-alone device additional charges for engineering, installation and maintenance will be tarified as identified under the Bona Fide Request Process described in <i>XIX.E.4.</i></p>	

**XIX. EXPANDED INTERCONNECTION SERVICES** (Continued)

<p>4. <i>Other Technologies</i></p> <p>EIS can be provided via other technologies, when reasonably feasible. These arrangements will be addressed only on a case-by-case basis. Rules, regulations and rates will be developed and filed upon receipt of a bona fide request from customers to provide alternate forms of interconnection.</p>	
<p>F. <u>Virtual EIS</u></p> <p>1. <i>Availability of Service</i></p> <p>a. Virtual EIS will be available to customers at all wire centers and access tandems except where the Oregon Public Utility Commission has granted exemption of wire centers or access tandems where existing suitable space or other conditions prohibit the provision of EIS.</p>	
<p>The Company will work cooperatively with a customer placing a bona fide request for service at this location to provide alternative service.</p>	
<p>b. Virtual EIS provides the means to interconnect, through an optical channel interface, to specified intrastate Access Services. Virtual EIS provides:</p> <p>(1) Connection between customer provided and Company provided fiber optic transport facilities at a meet point within the mutually agreed to Company designated space outside a Company wire center or access tandem, such as a manhole, and</p>	
<p>(2) Conversion of optical to electrical signals, as appropriate, to allow interconnection between customer provided transport facilities and other specified intrastate Company services.</p>	
<p>c. The interconnection point for virtual EIS is the demarcation between ownership of the cable facilities.</p>	
<p>d. The Company will designate mutually agreed upon locations close to the wire center or access tandem to be used as interconnection points for customer facilities.</p>	
<p>e. None of the provisions of Section XIX.E.4. apply or extend to any patron of the customer purchasing virtual EIS from the Company.</p>	
<p>2. <i>Obligations of the Customer</i></p> <p>a. When ordering virtual EIS, the customer shall designate the type of wire center or access tandem transmission equipment dedicated to their use. The customer may specify equipment which may be different from the equipment normally used by the Company to provide intrastate Access Services.</p>	
<p>b. The customer may monitor and control the performance of all facilities and equipment used in the provision of virtual EIS.</p>	
<p>c. The customer is responsible for initiating a request for maintenance of customer's facilities and termination equipment.</p>	

**XIX. EXPANDED INTERCONNECTION SERVICES** (Continued)

<p>d. The customer is responsible for costs associated with training Company employees to install and maintain equipment other than equipment normally used by the Company.</p>	
<p>e. The Company and the customer will work cooperatively to determine proper equipment and facilities requirements.</p>	
<p><b>3. Operation and Maintenance</b></p> <p>Where the Company uses contractors for installation, maintenance or repair of services, the customer may hire the same contractor directly for installation, maintenance or repair of customer designated equipment.</p>	
<p>Where the Company does not use contractors, customer designated equipment and customer provided facilities used in the provision of virtual EIS will be installed, maintained and repaired by the Company. The Company will maintain and repair the customer designated termination equipment under the same time frame and standards as its own equipment.</p>	
<p><b>4. Customer Terminating Equipment Requirements</b></p> <p>a. Customer equipment installed in the Company manhole or similar location must comply with either the Company's list of approved products, or equipment that complies with wire center or access tandem environmental and transmission standards in effect at the time the interconnection is made. This list of approved products and/or equipment is the same as used by the Company and its contractors. EIS customers will be notified of any change in the Company's list of approved products and/or equipment.</p>	
<p>b. The customer shall be responsible for supplying the following:</p> <p>Fiber Optic Cable and Fire Retardant Sheath Equipment located within the wire center or access tandem</p>	
<p>c. The customer shall be required to provide DS1 cable facilities in sufficient capacity for the Company to wire DS1 services in multiples of twenty-eight (28).</p>	
<p>d. The customer shall be responsible for bringing its outside plant cable to the wire center or access tandem manhole and leave sufficient cable length in order for the Company to be able to fully extend such cable through to the customer's space. No splicing will be permitted in the manhole. Upon discontinuance of EIS the customer relinquishes all rights, title and ownership of cable to the Company.</p>	
<p>e. The Company is responsible for installing customer provided cable in the cable space or conduit from the manhole to the wire center or access tandem. This may be shared conduit with dedicated inner duct. The customer shall not be permitted to reserve wire center or access tandem cable space or conduit. If new conduit is required, the Company will negotiate with the customer to determine the specific location. The Company reserves the right to manage its own wire center or access tandem conduit requirements and to reserve vacant space for planned facility additions.</p>	

**XIX. EXPANDED INTERCONNECTION SERVICES** (Continued)

<p>f. The Company is responsible for installing a cable splice where the customer provided cable meets customer provided fire retardant riser cable within the wire center or access tandem cable vault or designated splicing chamber. The Company will provide space and racking for the placement of the splice enclosure. The Company will tag all entrance facilities to indicate ownership. The Company is responsible for placing the customer's fire retardant riser cable from the cable vault to the terminating equipment. The customer is responsible for providing fire retardant riser cable that meets Company standards.</p>	
<p>g. Customer interconnection equipment installed with the Company's wire center or access tandem facilities shall be subject to and comply with Company practices for ac/dc bonding and grounding requirements. This information will be provided to the customer in the general information packet.</p>	
<p>h. Upon installation of the customer's equipment, with prior notice, the Company will schedule time to work with the customer during the turn-up phase of the equipment to ensure proper functionality between the customer's equipment and the connections to the Company equipment. The time period for this to occur will correspond to the Company's maintenance window time period. The maintenance window time is off-peak hours 12:00 AM (midnight) to 6:00 AM. During this time, the Company will schedule time to work with the customer during the turn-up phase of equipment to ensure proper functionality between the customer's equipment and the connections to the Company equipment.</p>	
<p>i. All equipment installed within the Company wire center and access tandem facilities shall meet the industry standard requirements.</p>	
<p><b>G. <u>Rate Regulations</u></b></p> <p>This section contains specific regulations governing the rates and charges that apply for EIS. These charges are in addition to the applicable rates and charges for the Switched and Special Access Service ordered, as specified in Sections V. and VI. of this tariff.</p> <p><b>1. <i>Types of Rates and Charges</i></b></p> <p>There are two (2) types of rates and charges. These are monthly rates and nonrecurring charges.</p> <p>a. <b>Monthly Rates</b></p> <p>Monthly rates are recurring charges that apply each month or fraction thereof that an EIS is provided. Monthly rates for EIS will commence upon completion of the customer's partitioned space, irrespective of when the Switched or Special Access service is connected.</p> <p>(1) The Cable Space Charge is a monthly recurring charge, applied per cable, associated with the space within the conduit, riser, cable racks, manhole and cable vault which the customer's cable occupies.</p>	
<p>(2) <b>Maintenance</b></p> <p>The Maintenance Charge is a monthly recurring charge associated with maintenance of the customer designated termination equipment. The charge is applicable per base module.</p>	

**XIX. EXPANDED INTERCONNECTION SERVICES** (Continued)

<p>(3) Power Equipment</p> <p>The Power Equipment Charge is a monthly recurring charge applicable to Virtual EIS arrangements for costs associated with power equipment provided by the Company, including but not limited to cabling, fuse panels, power and floor space. This charge is dependent upon the type of customer designated equipment. This charge applies for each 20 Amp increment of power.</p>	
<p>(4) Interconnect Cable</p> <p>The interconnect cable charge is a monthly recurring charge applicable to virtual arrangements for costs associated with jumper wire to connect via a 4-wire path the DSX-patch panel to the customer's terminating equipment. This charge is applied on a per linear foot basis.</p>	
<p>b. Nonrecurring Charges</p> <p>Nonrecurring charges are one-time charges that apply for specific work activity. The types of nonrecurring charges that apply for EIS are listed in this tariff.</p> <p>(1) Cable Pull Charge</p> <p>The Cable Pull Charge is associated with the work performed by the Company associated with the time and materials required to pull and splice, the customer's cable from the manhole to the cage.</p>	
<p>This charge applies per wire center or access tandem, per cable terminated.</p>	
<p>(2) Engineering/Installation Fee</p> <p>The Engineering/Installation Fee is associated with work performed by the Company to determine space requirements, engineer adequate amounts of power to the equipment, ensure adequate fire protection and install customer designated termination equipment. Separate charges apply for the installation of the base unit and each DS1 or DS3 card.</p>	
<p>(3) Training</p> <p>The Training Charge is associated with the costs incurred by the Company to train Company personnel on equipment that the Company does not use in normal operations within the requested central office for the provision of virtual EIS. The interconnecting customer will be responsible for the arrangement and payment for required training seminars, including tuition and related course materials. The technicians training time will be based on labor rates as specified in Section VII.B.6. and will be billed per hour or fraction thereof. When travel is required, travel expenses associated with training will be charged to the interconnecting customer based directly on ticket stubs and/or receipts.</p>	

**XIX. EXPANDED INTERCONNECTION SERVICES** (Continued)

(4) Power Equipment Installation		
The Power Equipment Installation Charge is associated with the equipment used by the Company to provide power supply for virtual EIS arrangements. This charge applies for each 20 Amp increments of power installed.		
2. <i>Minimum Periods</i>		
a. The Minimum Period applicable to monthly EIS rate elements specified is six (6) months.		
b. When EIS is discontinued prior to the expiration of the Minimum Period, charges are applicable for the remaining month(s) and/or fraction thereof of the Minimum Period.		
H. <u>Virtual EIS Rates and Charges</u>		
1. <i>Cable Rates and Charges</i>		
	<u>Nonrecurring Charge</u>	<u>Monthly Charge</u>
Cabled Space, Per Cable		
Aloha	\$1,325.00	\$24.98
Beaverton	1,404.00	45.45
Gresham	1,507.00	61.06
Hillsboro	1,698.00	93.72
Somerset West	1,390.00	47.72
Tigard	1,519.00	53.00
Charges Related to Customer Equipment	ICB	
Interconnect Cable, per linear foot	---	.30

**XIX. EXPANDED INTERCONNECTION SERVICES** (Continued)

<i>2. Equipment Rates and Charges</i>	
	<u>Monthly Charge</u>
Power Equipment, per 20 Amps of power	\$184.99
Maintenance, per termination	211.96
	<u>Nonrecurring Charge</u>
Engineering/Installation Fee per base module	
90 Mbps	4,078.52
OC3	4,751.88
OC12	5,425.24
OC48	7,009.20
Engineering/Installation Fee per card installed	
90 Mbps DS1	259.40
90 Mbps DS3	532.58
OC3 DS1	259.40
OC3 DS3	532.58
OC12 DS3	532.58
OC48 DS3	532.58
Power Equipment Installation, per 20 Amps of power	2,078.20
Training, per wire center	ICB



## XX. PROMOTIONS

<u>Location</u>	<u>Dates</u>	<u>Purpose</u>
Company's State Service Territory	8/18/08 – 11/14/08	<p>DS1, DS3 and Transparent LAN Services (TLS)</p> <p>Business customers with \$4,000 to \$250,000 in annual billing from the Company may be eligible to receive an American Express gift card when purchasing the qualified transport products listed above during this promotion.</p> <p>This promotion is available with new sales, renewals and upgrades purchased with a minimum two (2) year term agreement for DS1 and DS3 Service or a minimum three (3) year term agreement for TLS 10 Mbps or higher Service.</p> <p>Renewals must be within six (6) months of current contract expiration to qualify for this promotion.</p> <p>American Express gift cards amounts are based on the product, the term agreement and the additional Company product or service (associated equipment, Local Voice solution, or Business Internet Dedicated Access) purchased with products listed below. The amounts listed are per circuit.</p> <p>DS1 - \$300 - 2 yr OPP DS3 - \$1,000 - 2 yr OPP TLS - Ethernet Multipoint Service or Ethernet Relay Service - 3 yr OPP</p> <p>Winback customers are eligible to receive an additional gift card amount as follows:</p> <p>DS1 - \$200 – 2 yr OPP DS3 - \$750 – 2 yr OPP TLS - \$750 – Ethernet Multipoint Service or Ethernet Relay Service - 3 yr OPP</p> <p>Customers contacting the Company to disconnect their service are eligible to receive a gift card in the amounts listed in the Winback offer if they agree to stay with the Company for the minimum term agreement period.</p> <p>Gift cards are American Express gift cards that are redeemable at selected merchants: Casio, Computer Direct, Franklin Covey, Hitachi, JVC, FedEx Kinkos, Panasonic and Staples. Gift cards expire one year from issuance. Once service has been installed, customers will receive an email from the Company to verify contact information for sending the gift card. Customers must reply and provide verification by 12/31/08 in order to receive the gift card.</p>

**XX. PROMOTIONS** (Continued)

<u>Location</u>	<u>Dates</u>	<u>Purpose</u>
Statewide	7/1/05 – 12/31/05	<p>High Capacity Digital DS1 (1.544 Mbps) OPP promotion:</p> <p>Existing DS1 customers are not eligible for this promotion.</p> <p>New DS1 customers ordering a maximum of one (1) or two (2) DS1 lines are eligible for this promotion. Customers must subscribe to a one (1), thee (3), or five (5) year Optional Payment Plan (OPP).</p> <p>DS1 (1.544Mbps) Components:</p> <ol style="list-style-type: none"> <li>1) Special Access line, per line               <ul style="list-style-type: none"> <li>\$175.00 1 yr OPP</li> <li>\$145.00 3 yr OPP</li> <li>\$140.00 5 yr OPP</li> </ul> </li> <li>2) Special Transport Termination               <ul style="list-style-type: none"> <li>\$30.00 all OPPs</li> </ul> </li> <li>3) Interoffice Special Transport, per airline mile               <ul style="list-style-type: none"> <li>\$8.00 1 yr OPP</li> <li>7.00 3 yr OPP</li> <li>6.00 5 yr OPP</li> </ul> </li> </ol> <p>Early termination charges applicable with this promotion are seventy-five percent (75%) of the MRCs for the remainder of the term. See Section III.D.5. for description and calculation of early termination charges.</p> <p>Provisions of this promotion will be retained for the duration of the customer's chosen plan and depending on the plan chosen, may be effective through December 31, 2010.</p> <p>Provisions of this plan are not to extend beyond the term commitment period originally chosen by the customer.</p>

**XX. PROMOTIONS** (Continued)

<u>Location</u>	<u>Dates</u>	<u>Purpose</u>
Statewide	7/1/05 – 12/31/05	<p>Frame Relay DS1 (1.536 Mbps) OPP Discount:</p> <p>Existing Frame Relay customers are not eligible for this promotion.</p> <p>To qualify for this promotion, new Frame Relay customers must order a minimum of two UNI Port and Access Line Frame Relay circuits and subscribe to a one (1), three (3) or five (5) year Optional Payment Plan (OPP).</p> <p>Frame Relay DS1 UNI Port and Access Line: \$474.00 1 Year OPP \$447.00 3 Year OPP \$418.00 5 Year OPP</p> <p>Early termination charges applicable with this promotion are thirty percent (30%) of the MRCs for the remainder of the term. See Section <i>III.D.5.</i> for a description and calculation of early termination charges.</p> <p>Provisions of this promotion will be retained for the duration of the customer's chosen plan and depending on the plan chosen, may be effective through December 31, 2010.</p> <p>Provisions of this promotion are not to extend beyond the term commitment period originally chosen by the customer.</p>

**XX. PROMOTIONS** (Continued)

<u>Location</u>	<u>Dates</u>	<u>Purpose</u>
Statewide	7/5/05 – 9/30/05	<p>New and existing Business Customers may be eligible to receive a gift card per circuit when subscribing to Frame Relay (FR) service during this promotion. Qualifying circuits must include a UNI port and Access Line.</p> <p>Following is the criteria for determining eligibility:</p> <p>Customers Company annual billed revenue must be less than \$120,000.</p> <p>New sales and upgrades must be purchased with a minimum two (2) year term agreement.</p> <p>Existing customers that renew their current service must subscribe to at least a three (3) year term agreement.</p> <p>Amounts of gift cards follow:            \$2,000 per 45Mbps FR circuit            \$1,000 per 4-22Mbps FR circuit            \$750 per 384Kbps FR circuit</p> <p>1.5Mbps Frame Relay service not applicable for this promotion.</p>
Statewide	7/11/05 – 10/7/05	<p>New and existing business Customers may be eligible to receive a \$2,000 gift card per circuit when subscribing to DS3 point to point service.</p> <p>Following is the criteria for determining eligibility:</p> <p>Available to customers with Company annual billed revenues at \$120,000 or less.</p> <p>New sales and upgrades must be purchased with a minimum two (2) year term agreement.</p> <p>Existing customers that renew their current service must subscribe to at least a three (3) year term agreement.</p>

**XX. PROMOTIONS** (Continued)

<u>Location</u>	<u>Dates</u>	<u>Purpose</u>	
Statewide	7/1/10 – 9/30/10	A waiver of the IntraLATA Carrier (IPIC) Change Charge (\$4.35) is available to the Company's or Northwest Fiber, LLC's residence or business customers (local toll or long distance) who change their provider to any other carrier during the promotional period.	