



SUZANNE PRINSEN
Direct (503) 595-3927
suzanne@mrg-law.com

April 7, 2023

VIA ELECTRONIC FILING

Public Utility Commission of Oregon
Filing Center
P.O. Box 1088
201 High Street S.E., Suite 100
Salem, OR 97308-1088

Re: Docket No. PCN 5 – In the Matter of Idaho Power Company’s Petition for Certificate of Public Convenience and Necessity.

Attention Filing Center:

Attached for filing in the above-referenced docket is Idaho Power Company's Surrebuttal Testimony and Exhibits of Josph Stippel (Idaho Power/1900-1905).

Please contact this office with any questions.

Thank you,

Suzanne Prinsen
Legal Assistant

Attachments

DOCKET PCN 5 - CERTIFICATE OF SERVICE

I hereby certify that on April 7, 2023 Idaho Power Company's Surrebuttal Testimony of Joseph Stippel was served by USPS First Class Mail and Copy Center to said person(s) at his or her last-known address(es) as indicated below:

By: USPS First Class Mail and Copy Center:

John C. Williams
PO Box 1384
La Grande, OR 97850

Copies Plus
1904 Adams Ave,
La Grande, OR 97850
(541) 663-0725
copiespluslg@yahoo.com

DATED: April 7, 2023

/s/ Suzanne Prinsen
Suzanne Prinsen
Legal Assistant

Table of Contents

I. Responses to the Rebuttal Testimony of Sam Myers2
II. Response to the Rebuttal Testimony of Stop B2H..... 10

Exhibit List

- Idaho Power/1901 – FEMA Fact Sheet: Highlights of Significant Changes to the Wind Load Provisions of ASCE 7-22
- Idaho Power/1902 – Updated Oregon Building Code with October 2022 Amendments
- Idaho Power/1903 – Excerpt from Myers Data Response - Narrative Describing Figure 3-1
- Idaho Power/1904 – Report from the National Weather Service on the Enhanced Fujita (“EF”) Scale
- Idaho Power/1905 – National Oceanic and Atmospheric Administration Storm Events Database – Tornadoes in Oregon from 01/01/1950 to 12/31/2022

1 I. INTRODUCTION AND SUMMARY

2 Q. Please state your name, your place of employment, and your position.

3 A. My name is Joseph (or “Joe”) Stippel. I am employed by Idaho Power Company (“Idaho
4 Power” or the “Company”) as the Principal Project Manager in the 500-kilovolt (“kV”)
5 Projects Group. I am the current project manager for the Boardman to Hemingway
6 Transmission Line Project (“B2H” or the “Project”).

7 Q. Are you the same Joe Stippel that previously filed Reply Testimony in this matter?¹

8 A. Yes.

9 Q. What is the scope and purpose of your Surrebuttal Testimony?

10 A. In this testimony, I will respond to the Rebuttal Testimony of Sam Myers regarding
11 engineering and wind loading issues, and to STOP B2H regarding the operating voltage
12 for B2H.

13 Q. Have you previously testified on the topic of wind loading?

14 A. Yes. In my Reply Testimony I responded to the testimony of Sam Myers on wind loading
15 issues.²

16 Q. Please summarize your Surrebuttal Testimony.

17 A. In my Surrebuttal Testimony, I first summarize each of Mr. Myers’ assertions and
18 suggestions that Idaho Power reassess the design of the transmission towers for B2H. I
19 respond to many of Mr. Myers’ assertions by referencing the Final Order on the Application
20 for Site Certificate (“ASC”) for B2H at the Oregon Energy Facility Siting Council (“EFSC”)
21 and my previous testimony. Additionally, I address where Mr. Myers has misinterpreted
22 engineering principles to analyze the risk of wind loading on B2H. Finally, I respond to an
23 assertion in the STOP B2H Coalition’s (“STOP B2H”) Rebuttal Testimony regarding

¹ Idaho Power/1500-1501 (Feb. 21, 2023).

² Idaho Power/1500, Stippel/9-14.

1 overbuilding by noting that 500-kV transmission lines typically have a higher normal
2 operating voltage. In general, I conclude that the transmission towers that will be used in
3 B2H meet all applicable engineering standards and the Company has adequately
4 addressed all safety risks.

5 **II. RESPONSES TO THE REBUTTAL TESTIMONY OF SAM MYERS**

6 **Q. Please summarize Mr. Myers' Rebuttal Testimony regarding the calculated wind**
7 **speed and Mean Recurrence Interval ("MRI") for the B2H route.**

8 A. Mr. Myers cites to my Reply Testimony regarding standards from the American Society of
9 Civil Engineers ("ASCE"), specifically ASCE 7 which pertains to design loads for
10 structures.³ Mr. Myers notes that based on this standard, Idaho Power determined that
11 the 100-year MRI for the area around his property is 85 miles per hour ("mph").⁴ Mr. Myers
12 asserts that this number is under-representative of actual wind speeds in the area which,
13 based on data from a wind metering tower on Carpenter Butte, can gust as high as
14 88.4 mph.⁵ Mr. Myers includes data from this tower which shows a maximum wind speed
15 in 2012 and 2014 of 79.2 and 88.4 mph, respectively.⁶ Mr. Myers thus concludes that the
16 fact that a "50 year event and a 100 year event" happened within two years shows that
17 Idaho Power is underestimating the basic wind speed for B2H.⁷

18 **Q. Is Mr. Myers' interpretation of the MRI correct?**

19 A. No. The wind speed MRI represents the probability that the given wind speed will occur
20 in a particular year. As I detailed in my Reply Testimony, Idaho Power selected a 100-
21 year MRI for the determination of wind speed in the vicinity of the Myers property.⁸ That
22 MRI is 85 mph, meaning that there is a one percent chance that a three-second wind gust

³ Rebuttal Testimony of Sam Myers at 2 of 20 (Mar. 20, 2023).

⁴ Rebuttal Testimony of Sam Myers at 2 of 20.

⁵ Rebuttal Testimony of Sam Myers at 2 of 20.

⁶ Rebuttal Testimony of Sam Myers at 2 of 20.

⁷ Rebuttal Testimony of Sam Myers at 2 of 20.

⁸ Idaho Power/1500, Stippel/13-14.

1 will exceed that value in a given year.⁹ This number does not represent the maximum
2 wind speeds in the area. Thus, Mr. Myers' assertion regarding the 88.4 mph recording
3 has no bearing on the accuracy of the MRI.

4 **Q. What is your response to Mr. Myers' assertion that the occurrence of two high speed**
5 **wind events means that basic wind speed is underrated?**

6 A. Mr. Myers' argument misinterprets basic statistical principles. The 100-year MRI means
7 that there is a one percent chance of a specific wind speed occurring in any given year.
8 The probability of occurrence in one year is independent of the probability of occurrence
9 in another year.

10 **Q. Assuming the accuracy of Mr. Myers' wind speed data, is B2H designed to**
11 **withstand such wind events?**

12 A. Yes. B2H is designed with a wind loading of 120 mph on the lattice towers and 100 mph
13 loading in wire, resulting in an MRI of between 700 and 10,000 years.¹⁰ Thus, the B2H
14 towers will be able to withstand the maximum wind event of 88.4 mph that Mr. Myers cites
15 to, even if that event were to occur every year.

16 **Q. Mr. Myers states that the data gathered from the Carpenter Butte wind metering**
17 **tower is a reasonable measurement of wind speed in the area around B2H. What is**
18 **your response?**

19 A. As I stated in my Reply Testimony, design wind speeds in transmission engineering are
20 not the same as instantaneous wind speeds.¹¹ Thus, the instantaneous wind speeds
21 provided by Mr. Myers are not indicative of the design wind speeds for B2H. Further, the
22 wind maps published by ASCE show no recent changes to design speeds for the B2H
23 regions and that the Project site does not contain a "special wind region" that would

⁹ Idaho Power/1500, Stippel/13.

¹⁰ Idaho Power/1500, Stippel/13.

¹¹ Idaho Power/1500, Stippel/12.

1 warrant further analysis.¹²

2 **Q. Mr. Myers asserts that B2H should be designed to the wind speed standards in the**
3 **Oregon Building Codes.¹³ From your understanding, are the Oregon Building**
4 **Codes applicable to transmission tower design?**

5 A. No. The Oregon Building Codes do not apply to B2H and are not a requirement for
6 constructing transmission towers in Oregon. In fact, the code specifically excludes public
7 utility towers and poles from the code's authority¹⁴ and generally applies only to buildings.
8 Transmission lines are not "buildings" and are required to meet National Electrical Safety
9 Code ("NESC") standards. The NESC references ASCE 7 as a guideline for determining
10 a design wind speed, and does not reference Oregon Building Codes or any other
11 code/standard that may apply for building design.

12 **Q. Mr. Myers also asserts that B2H should be designed in accordance with the National**
13 **Institute of Standards and Technology ("NIST") standards.¹⁵ Are these standards**
14 **applicable to B2H?**

15 A. No. From my understanding, no NIST standards apply to transmission towers nor are
16 these standards a requirement to construct such facilities in Oregon.

17 **Q. Mr. Myers references the ANSI/TIA-22 standard for telecommunications**
18 **structures.¹⁶ Is this standard applicable to B2H?**

19 A. No. From my understanding, ANSI/TIA-22 standards do not apply to transmission towers.

20 **Q. Mr. Myers' testimony includes a chart from the Bonneville Power Administration**
21 **("BPA") showing the number of tower failures from 1948-2009.¹⁷ What is your**

¹² See generally Idaho Power/1901 (FEMA Fact Sheet: Highlights of Significant Changes to the Wind Load Provisions of ASCE 7-22).

¹³ Rebuttal Testimony of Sam Myers at 3 of 20.

¹⁴ Idaho Power/1902, Stippel/3 (Updated Oregon Building Code with October 2022 Amendments) (Oregon Structural Specialty Code § 101.2.2.1(5)).

¹⁵ Rebuttal Testimony of Sam Myers at 10 of 20.

¹⁶ Rebuttal Testimony of Sam Myers at 10 of 20.

¹⁷ Rebuttal Testimony of Sam Myers at 4 of 20.

1 **analysis of this chart?**

2 A. Idaho Power asked Mr. Myers for additional information concerning the chart in discovery,
3 and Mr. Myers provided a weblink to the report associated with the chart.¹⁸ As an initial
4 matter, I would note that the text in the report accompanying the chart indicates that the
5 tower failures analyzed were associated with transmission lines ranging from 115-kV to
6 500-kV, and thus do not specifically isolate data for 500-kV steel lattice structures.¹⁹
7 Additionally, there is one particularly large tower failure event in 2001, which is described
8 in the narrative as being associated with wood poles.²⁰ Based on the differences in
9 voltage—and the fact that 500-kV steel lattice towers associated with B2H are designed
10 to be robust and to meet or exceed applicable engineering standards, I do not believe that
11 the chart would be indicative of any likelihood of tower failure associated with B2H.

12 Finally, I would note that the report indicates the analysis in the figure does not
13 distinguish between towers damaged due to high winds versus unbalanced loads
14 (meaning one tower failure leading to additional tower failures), but based on empirical
15 analysis “unbalanced-load tower failures have not been common (in a few initiations,
16 perhaps 1 or 2 adjacent towers collapsed) in the BPA system.”²¹ The report further
17 indicates that—though the data is not conclusive—the data would imply that the BPA
18 tower configuration may be more resistant to unbalanced line loads.²²

19 **Q. Mr. Myers asserts that there is a significant risk of tornadoes and cyclones in the**
20 **Project area which could damage B2H.²³ Based on your understanding, are**

¹⁸ Idaho Power/1903 (Excerpt from Myers Data Response - Narrative Describing Figure 3 1).

¹⁹ Idaho Power/1903, Stippel/2 (Excerpt from Myers Data Response - Narrative Describing Figure 3 1).

²⁰ Idaho Power/1903, Stippel/3 (Excerpt from Myers Data Response - Narrative Describing Figure 3 1).

²¹ Idaho Power/1903, Stippel/3 (Excerpt from Myers Data Response - Narrative Describing Figure 3 1).

²² Idaho Power/1903, Stippel/3 (Excerpt from Myers Data Response - Narrative Describing Figure 3 1).

²³ Rebuttal Testimony of Sam Myers at 8 of 20.

1 **tornados or cyclones a risk to B2H?**

2 A. No. I based my determination off the National Weather Service's ("NWS") Enhanced
3 Fujita ("EF") Scale.²⁴ The EF scale measures the three-second wind speed for tornados
4 and is commonly used in engineering structural analysis. The only recorded tornados in
5 the region around B2H have been EF0 (three-second gusts of 65 to 85 mph) or EF1 (three-
6 second gusts of 86 to 110 mph).²⁵ As the Project is built to withstand wind gusts of up to
7 120 mph, even an EF1 tornado would likely not have sufficient wind speed to threaten the
8 integrity of B2H towers. As no tornado which is higher than EF1 on the EF scale has been
9 recorded in the region around B2H, I would conclude that there is minimal risk of a tornado
10 damaging a tower.²⁶

11 **Q. Mr. Myers asserts that Idaho Power should assess the possible damage to B2H**
12 **towers from a high wind event using the same standards as are used for buildings**
13 **and other structures.²⁷ Is this damage analogous to what would happen to a**
14 **transmission tower under the same conditions?**

15 A. No. Wind pressure on structures is dependent on a variety of items including wind shape.
16 Building design is very different from lattice steel design.

17 **Q. Please elaborate on the differences between a building and a transmission line as**
18 **it relates to wind pressure and design considerations.**

19 A. For buildings and transmission towers, not only is the shape and structure different, but
20 also the material selection is different. For a building, roof separation, for example, may
21 occur in buildings that are not heavily scrutinized during design due to local pressure

²⁴ Idaho Power/1904, Stippel/16, Table 6 (Report from the National Weather Service on the Enhanced Fujita ("EF") Scale).

²⁵ Idaho Power/1905 (National Oceanic and Atmospheric Administration Storm Events Database – Tornadoes in Oregon from 01/01/1950 to 12/31/2022); see also Idaho Power/1904, Stippel/16, Table 6 (Report from the National Weather Service on the Enhanced Fujita ("EF") Scale).

²⁶ Idaho Power/1905 (National Oceanic and Atmospheric Administration Storm Events Database – Tornadoes in Oregon from 01/01/1950 to 12/31/2022).

²⁷ See Rebuttal Testimony of Sam Myers at 10.

1 events that occur. Building designers are generally instructed to pay particular attention
2 to these connections in order to avoid catastrophic roof separation from the structure,
3 which in turn weakens the structure. Additionally, in areas where wind loading dictates,
4 hurricane ties are required in order to strengthen this vulnerable connection.

5 On the other hand, for transmission line design, lattice structures in particular are
6 subject to a tremendous amount of scrutiny and tower testing in order to assure the tower
7 can withstand design wind-loading events. Since 1914, the NESC has been the go-to
8 safety standard for electric and telecommunication utility companies of all sizes and
9 ownership of structures.

10 **Q. What is the relevant NESC standard in the location of concern for Mr. Myers?**

11 A. Specific to the location that Mr. Myers has raised, NESC Code 250C governs the B2H
12 structures, which are lattice steel, under BPA DT-35. As I explained in my Reply
13 Testimony, this design standard utilizes a maximum wind speed at 120 mph on the lattice
14 towers and 100 mph on the wire.²⁸ B2H follows the BPA STD-DT-000035 for lattice tower
15 loading, which gives the project an MRI from ASCE 7 of between a 700- and 10,000-year
16 recurrence period for the area of interest in Morrow County and Umatilla County.²⁹

17 **Q. Please summarize Mr. Myers' assertions regarding the seismic risk to B2H.**

18 A. Mr. Myers notes the risk of damage to B2H towers from an earthquake in the Project
19 area.³⁰ Mr. Myers asserts a particular concern with the risk of the Cascadia earthquake,
20 which is predicted to produce a 9.0 magnitude or higher earthquake.³¹ Mr. Myers argues
21 that Idaho Power did not consider this seismic event or design B2H to withstand this risk.³²

22 **Q. What is your response?**

²⁸ Idaho Power/1500, Stippel/13.

²⁹ Idaho Power/1500, Stippel/13.

³⁰ Rebuttal Testimony of Sam Myers at 6-7 of 20.

³¹ Rebuttal Testimony of Sam Myers at 6 of 20.

³² Rebuttal Testimony of Sam Myers at 7 of 20.

1 A. Mr. Myers' assertions lack basis. The EFSC Final Order included Structural Standard
2 Condition 3, which requires Idaho Power to:

3 design, engineer and construct the facility to avoid dangers to human safety
4 and the environment presented by seismic hazards affecting the site that
5 are expected to result from ***all maximum probable seismic events***. As
6 used in this rule "seismic hazard" includes ground shaking, ground failure,
7 landslide, liquefaction triggering and consequences (including flow failure,
8 settlement buoyancy, and lateral spreading), cyclic softening of clays and
9 silts, fault rupture, directivity effects and soil-structure interaction.³³

10
11 Thus, it is inaccurate to state that Idaho Power has ignored the seismic risk.

12 **Q. What is the anticipated magnitude of a Cascadia Subduction Zone ("CSZ")**
13 **earthquake in Oregon?**

14 A. As detailed in the Final Order, it is anticipated that a CSZ event has the potential to cause
15 an earthquake up to 9.0 magnitude.³⁴

16 **Q. Did Idaho Power consider the impacts of a CSZ interplate event in the development**
17 **of B2H?**

18 A. Yes. In its consideration of the seismic hazards along the Project route, Idaho Power
19 considered the risk to B2H from the CSZ. The Company determined that the source for
20 this earthquake will be located a minimum of 280 miles or more from the site boundary.³⁵
21 Thus, Idaho Power's consultant determined that the seismic shaking from the CSZ would
22 attenuate over that distance and not represent the most significant earthquake hazard for
23 the facility.³⁶ Instead, the consultant recommended that B2H's design be based on
24 earthquake magnitudes of 6.0 to 6.2.³⁷

25 **Q. Please summarize Mr. Myers' arguments regarding wind attack angle.**

³³ Idaho Power's Supplement to Petition for CPCN, Attachment 1 (Final Order, Attachment 1, Site Certificate) at 768 of 10603 (Oct. 7, 2022) (emphasis added).

³⁴ Idaho Power's Supplement to Petition for CPCN, Attachment 1 (Final Order) at 118 of 10603 [hereinafter, "Final Order"].

³⁵ Final Order at 118 of 10603.

³⁶ Final Order at 118-20 of 10603.

³⁷ Final Order at 119 of 10603.

1 A. Mr. Myers cites to an ASCE study regarding Fragility Analysis and asserts that the study
2 suggests that a wind attack angle of 67.5 degrees can dramatically increase the fragility
3 of the tower.³⁸ Mr. Myers suggests that this study shows the risk of B2H tower collapse
4 in high winds.³⁹

5 **Q. Did Idaho Power incorporate a fragility analysis into its tower design?**

6 A. No. Fragility studies are limited to threats under extreme weather loading conditions that
7 are not a code concern in the B2H region. Per NESC codes, the Project is located within
8 the "medium" loading district for ice/wind combinations. Regions with the combination of
9 both heavy ice and extreme wind or "heavy" loading districts (per NESC) are defined to
10 be in the Midwest and Northeastern regions of the United States. For this reason, fragility
11 studies are not done in this region and are not warranted.

12 **Q. Does the data and chart provided by Mr. Myers on wind attack angle⁴⁰ have any**
13 **bearing on the engineering of B2H towers for high wind events?**

14 A. No. From my understanding, a wind attack angle analysis would be performed as part of
15 a fragility analysis. As a fragility analysis is not warranted for the Project, wind attack
16 angle is not relevant to the construction of B2H towers.

17 **Q. Mr. Myers cites a study on Wind Induced Coupling Vibrations, which concluded that**
18 **vibrations on conductors induced by wind significantly increase as the wind speed**
19 **increases.⁴¹ Is this study relevant to the design of Idaho Power's B2H transmission**
20 **towers?**

21 A. No. Wind-induced coupling dynamics are not a basis for the design requirements as
22 identified by the ASCE codes. Should any outlier vibration events caused by high winds
23 occur, historically they are limited in size, highly unlikely for lattice towers, and cascading

³⁸ Rebuttal Testimony of Sam Myers at 5 of 20.

³⁹ Rebuttal Testimony of Sam Myers at 5-6 of 20.

⁴⁰ Rebuttal Testimony of Sam Myers at 5 of 20.

⁴¹ Rebuttal Testimony of Sam Myers at 9 of 20.

1 failures are contained between more robust dead-end towers.

2 **III. RESPONSE TO THE REBUTTAL TESTIMONY OF STOP B2H**

3 **Q. STOP B2H responds to the statement in the Reply Testimony of Mark Bastasch that**
4 **B2H will operate at 525 kV, asserting that this “begs the question” if Idaho Power is**
5 **overbuilding the transmission line.⁴² What is your response?**

6 A. This assertion misunderstands the nature of 500-kV lines. 500-kV transmission lines can
7 operate at 525 kV and 550 kV. The fact that B2H will operate at 525 kV approximately 50
8 percent of the time does not indicate that Idaho Power is overbuilding, but instead
9 represents the normal operating voltage for a 500-kV transmission line.

10 **Q. Does this conclude your Surrebuttal Testimony?**

11 A. Yes, it does.

⁴² STOP B2H's Rebuttal Testimony and Exhibits of Jim Kreider (STOP B2H/200, Kreider/23) (Mar. 20, 2023).

BEFORE THE PUBLIC UTILITY COMMISSION
OF OREGON

Docket PCN 5

In the Matter of

IDAHO POWER COMPANY'S
PETITION FOR CERTIFICATE OF PUBLIC CONVENIENCE
AND NECESSITY

Surrebuttal Testimony of Joseph Stippel

Exhibit 1901

FEMA Fact Sheet: Highlights of Significant Changes
to the Wind Load Provisions of ASCE
(July, 2022)

April 7, 2023

Highlights of Significant Changes to the Wind Load Provisions of ASCE 7-22

ASCE/SEI 7-22, *Minimum Design Loads and Associated Criteria for Buildings and Other Structures* (commonly referred to as ASCE 7-22), developed and published by the American Society of Civil Engineers (ASCE) and Structural Engineering Institute (SEI), will be the primary reference standard for structural loads in the 2024 *International Building Code*, 2024 *International Residential Code*, and the 8th Edition (2023) *Florida Building Code*. The standard specifies minimum structural design loads and other criteria for the design of buildings and other structures for dead, live, soil, flood, tsunami, snow, rain, atmospheric ice, earthquake, wind, and tornado loads. It also provides criteria on how to assess load combinations.

This overview highlights a few of the key significant changes to the wind loading design provisions contained in ASCE 7-22, as compared to the previous version (ASCE 7-16), that will affect building design. The topics in this overview include:

- Changes to the basic wind speed maps
- Change to the Wind-borne Debris Region (WBDR)
- Changes to the component and cladding external pressure coefficients (GC_p) for roofs of buildings with roof slopes greater than 7°

Changes to the Basic Wind Speed Maps

The basic wind speed maps in ASCE 7-22 have been revised primarily in hurricane-prone regions. These changes are the result of ongoing improvements to the hurricane simulation model that is used to develop the wind speeds in hurricane-prone regions. The changes also include better wind speed estimates in the areas where hurricane wind speeds transition to non-hurricane wind speeds adjacent to the hurricane-prone coast.

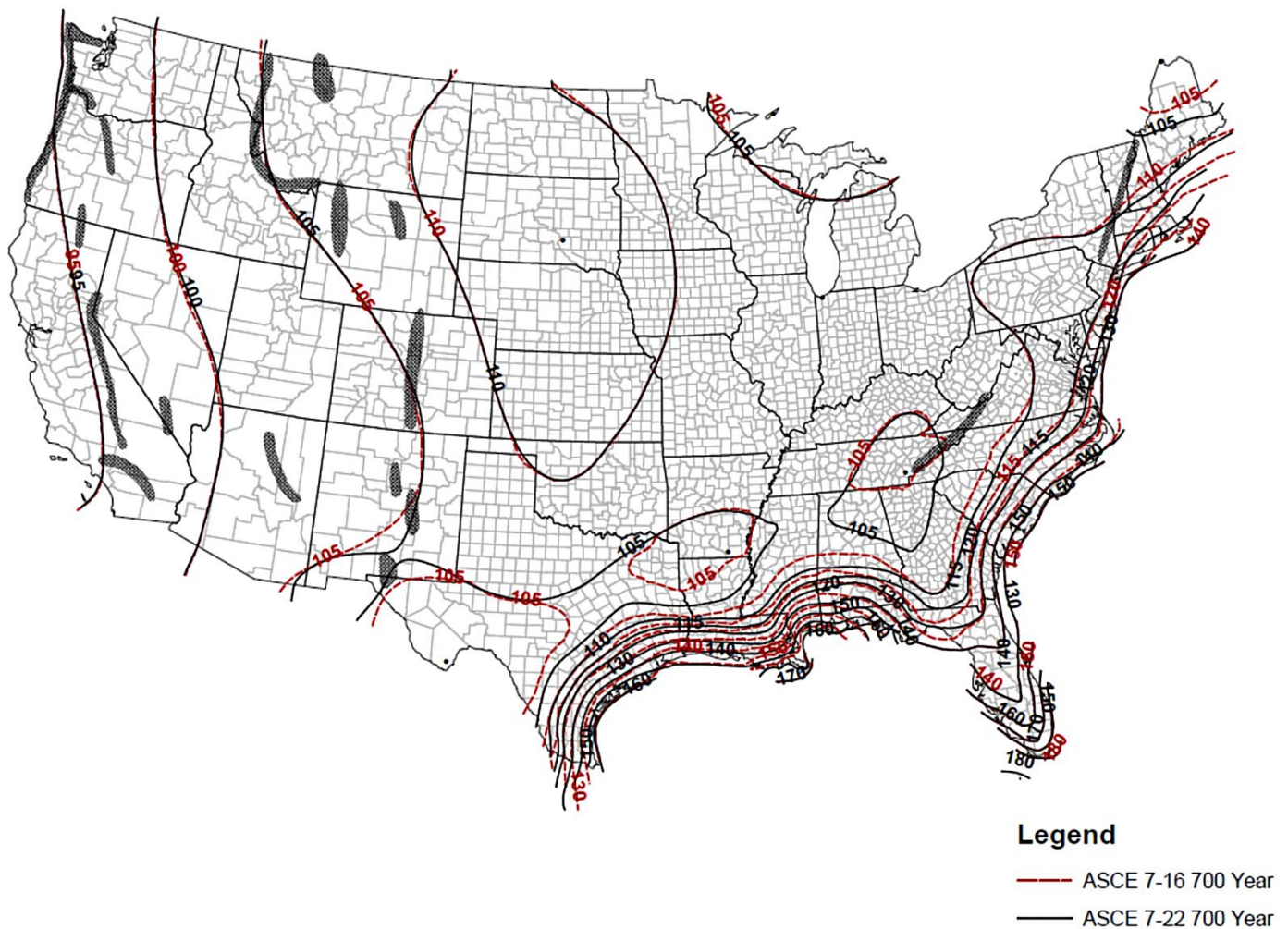
Summary of changes to basic wind speeds in hurricane-prone regions:

- Decreases along the North-Atlantic coast
- Minor adjustments in the Carolinas and Virginia
- Increases along the Florida panhandle and big bend areas
- Slight decreases along the coastal areas of Alabama, Mississippi, and Louisiana
- Increases along the coastal areas of Texas

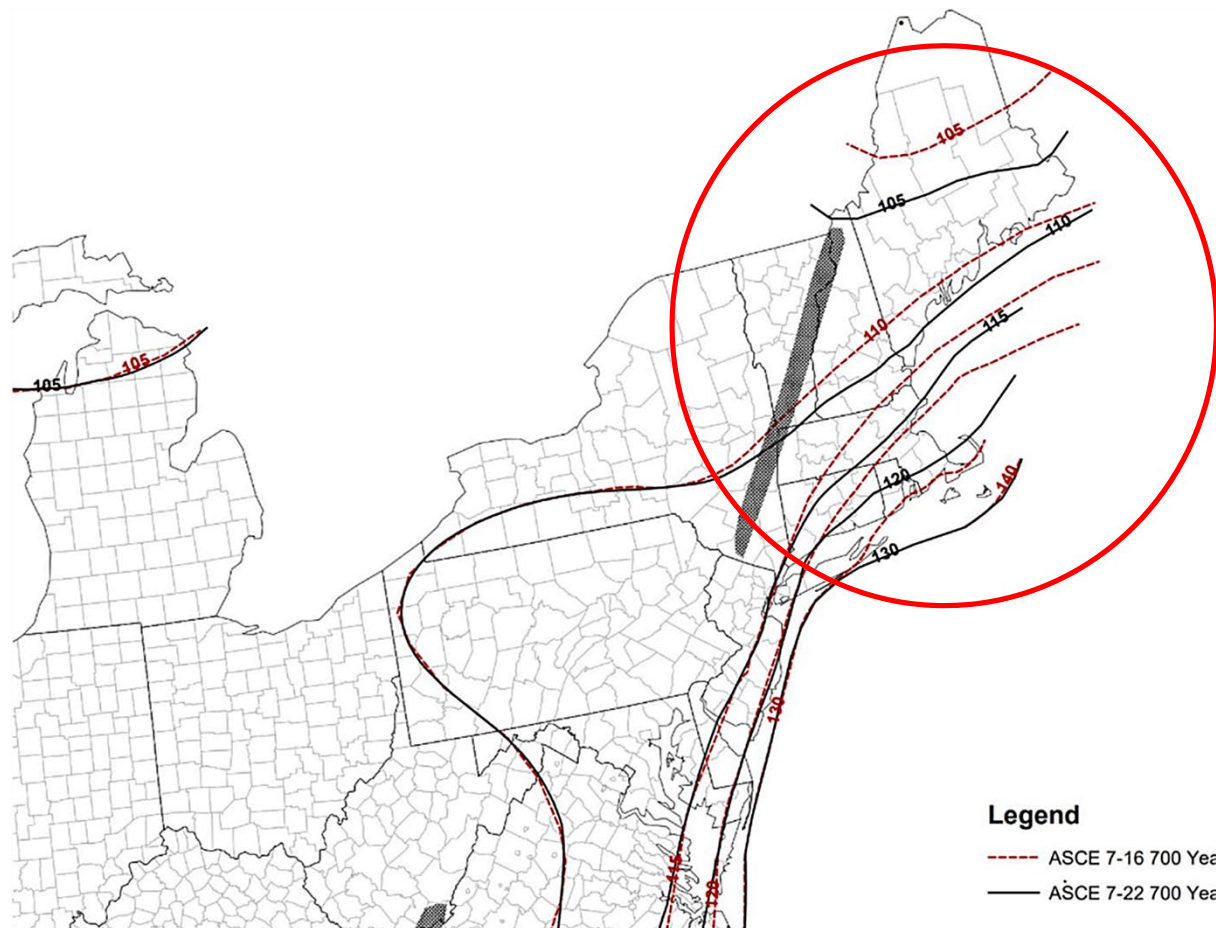


Figure 1 illustrates the changes to the basic wind speeds for Risk Category II buildings and structures in ASCE 7-22. The red dashed contours are the ASCE 7-16 Risk Category II wind speeds. The black contours are the ASCE 7-22 Risk Category II wind speeds. Similar adjustments occur for the Risk Category I, III, and IV maps.

Figure 2 provides a more detailed view of the changes along the North-Atlantic coast. Basic wind speeds for the North-Atlantic region have been decreasing from previous versions for the last three editions of ASCE 7. While wind speed contours have generally moved closer to the coast, reflecting slightly lower wind speeds, the shift of the 130-miles-per-hour (mph) contour completely off the coast is notable. (The 130 mph Risk Category II wind speed is the trigger in the *International Residential Code* for the *Wind Design Required Region* and one of the triggers for the *Wind-borne Debris Region*. The North-Atlantic is now completely out of both regions and conventional construction as permitted in the *International Residential Code* will be permitted throughout the area.)



(Source: Adapted from Figure 26.5-1B of ASCE 7-16 and Figure 26.5-1B of ASCE 7-22 with permission)
Figure 1: Comparison of basic wind speeds for Risk Category II buildings and structures in ASCE 7-16 and ASCE 7-22



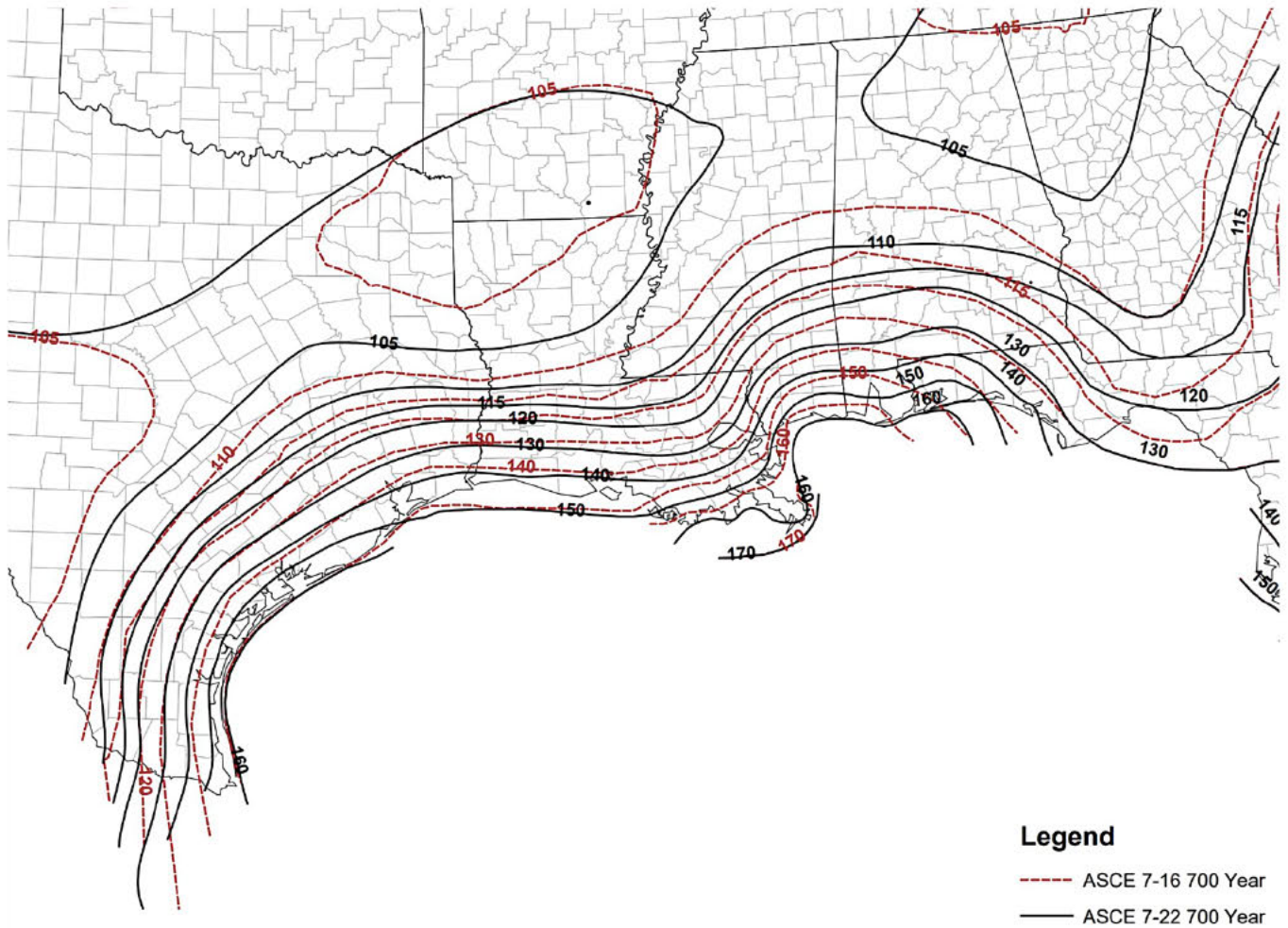
(Source: Adapted from Figure 26.5-1B of ASCE 7-16 and Figure 26.5-1B of ASCE 7-22 with permission)

Figure 2: Basic wind speed changes along the North-Atlantic coast for Risk Category II buildings and structures

Figure 3 provides a more detailed view of the changes along the Gulf coast. Along the south Texas coast, basic wind speeds have increased by approximately 10 mph. Further inland (130 mph and less) wind speeds are slightly lower.

Along the coastal areas of Louisiana, Mississippi, and Alabama wind speeds have generally decreased for most areas. The decrease is more significant in some areas than others. For example, the ASCE 7-16 Risk Category II wind speed for Mobile, Alabama, is 154 mph. In ASCE 7-22, the Risk Category II wind speed is 146 mph (approximately a 5% decrease). For Gulf Shores, Alabama, the wind speed is essentially the same in ASCE 7-22 as it is in ASCE 7-16.

In the Florida panhandle area, wind speeds have increased in some areas of the western part of the panhandle. For example, the ASCE 7-16 Risk Category II wind speed for Destin, Florida, is 142 mph. In ASCE 7-22, the Risk Category II wind speed is 152 mph (approximately a 7% increase). In the big bend area of Florida (informal region of Florida generally stretching from the Apalachicola River to the St. Johns River), the wind speeds have increased from ASCE 7-16, but are essentially the same as they were in ASCE 7-10. (While the 7th Edition (2020) *Florida Building Code* did adopt ASCE 7-16, it did not adopt the ASCE 7-16 Risk Category II basic wind speed map and maintained the ASCE 7-10 Risk Category II basic wind speed map.)



(Source: Adapted from Figure 26.5-1B of ASCE 7-16 and Figure 26.5-1B of ASCE 7-22 with permission)

Figure 3: Basic wind speed changes along the Gulf coast for Risk Category II buildings and structures

Changes to the Wind-borne Debris Region

As with ASCE 7-16, areas within hurricane-prone regions where the basic wind speed is 140 mph or greater are included in the WBDR unconditionally. However, the location of the WBDR has undergone a small but significant change in hurricane-prone regions where the basic wind speed is less than 140 mph but greater than or equal to 130 mph. The locations where the WBDR applies has been revised as follows:

ASCE 7-22

26.12.3.1 Wind-Borne Debris Regions. Glazed openings shall be protected in accordance with Section

26.12.3.2 in the following locations:

- Within 1 mi (1.6 km) of the **coastal** mean high water line where **an Exposure D condition exists upwind of the water line and** the basic wind speed is equal to or greater than 130 mi/hr (58 m/s), or
- In areas where the basic wind speed is equal to or greater than 140 mi/h (63 m/s).

Highlights of Significant Changes to the Wind Load Provisions of ASCE 7-22

The term “coastal mean high-water line” is not a defined term, and its interpretation has varied across jurisdictions in the hurricane-prone region due to confusion about the intent. The new criteria in ASCE 7-22 deletes the word “coastal” and adds language to require that an Exposure D condition exist upwind of the water line. This trigger now applies to locations that are within a mile of any body of water (located in hurricane-prone regions where the basic wind speed is equal to or greater than 130 mph and less than 140 mph) and an Exposure D condition exists upwind of the water line. In hurricane-prone regions, Exposure D applies where a water exposure prevails in the upwind direction for 5000 feet or 20 times the height of the building. The impact of this change is illustrated in Figure 4 for the Panama City area of Florida where the basic wind speed ranges from 130 mph to 140 mph.

For area A, buildings within 1 mile of the mean high-water line of the Gulf of Mexico where the basic wind speed is equal to or greater than 130 mph are clearly within the WBDR. However, for area B, the initial point to measure “1 mile from the coastal mean high-water line” was not clear in ASCE 7-16 and earlier editions. In ASCE 7-22, this ambiguity has been removed. In the bay area (area B), any building located within 1 mile of the mean high-water line of the bay that has exposure to a water surface that prevails for at least 5000 feet from the shoreline will be in the WBDR.



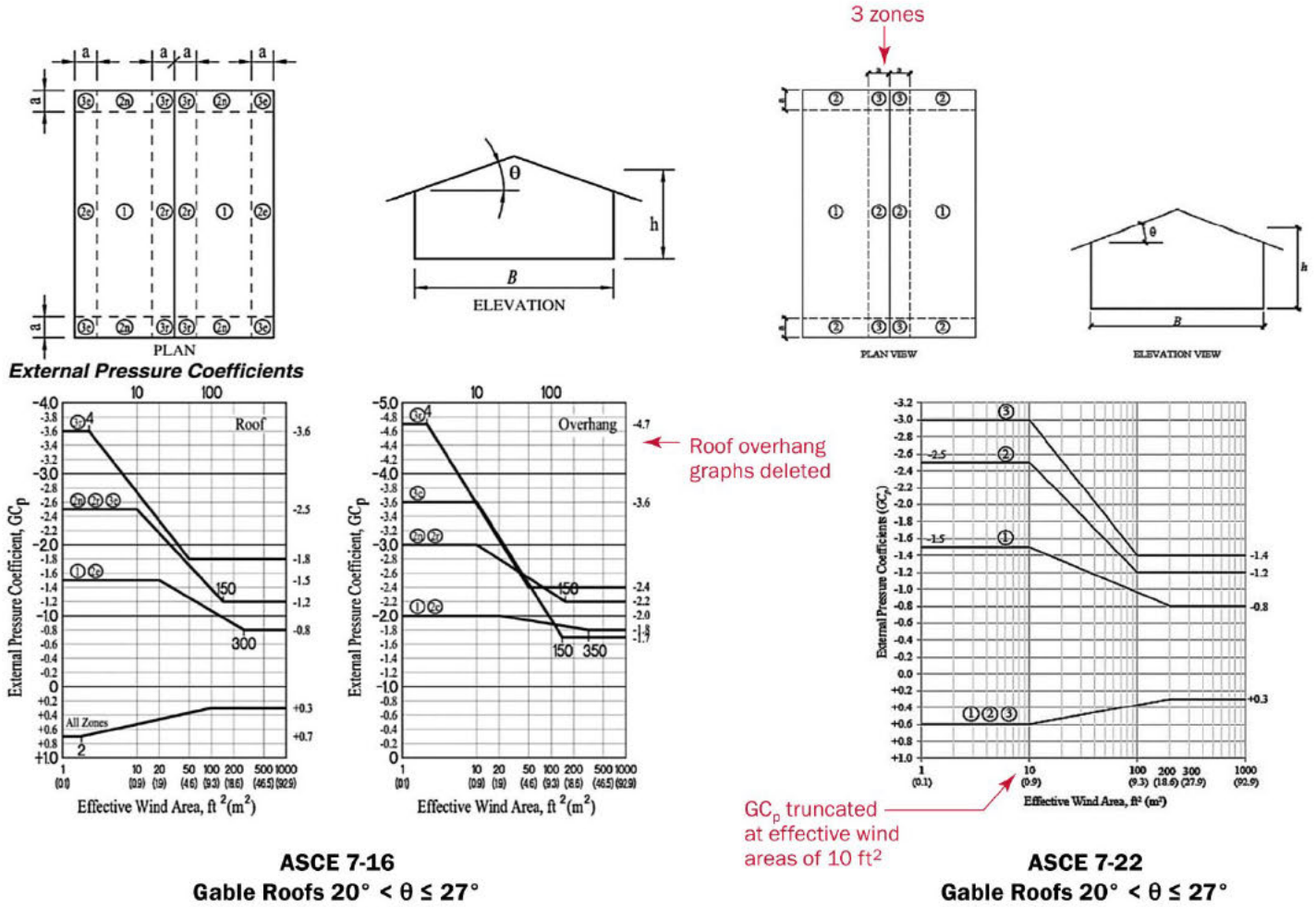
Figure 4: Changes to the location of the WBDR in ASCE 7-22

Changes to External Pressure Coefficients for Roofs of Buildings with Gable and Hip Roofs Having Slopes Greater than 7 Degrees

Component and cladding external pressure coefficients, GC_p , have been revised again in ASCE 7-22 for buildings with gabled and hipped roofs and roof slopes greater than 7° . The changes represent simplifications to the zones on the roofs and lower pressure coefficients for some zones. The external pressure coefficients for flat roofs ($\theta \leq 7^\circ$) are unchanged from ASCE 7-16. For buildings with gable and hip roofs and slopes of $7^\circ < \theta \leq 45^\circ$, the changes include:

- Simplified log graphs with three zones
- All zones truncated at effective wind areas of 10 square feet (ft^2)
- Roof overhang loads determined by summing the roof surface GC_p with the adjacent wall surface GC_p

The changes mostly result in no change or reductions in roof pressure coefficients and corresponding design loads on buildings with roof slopes greater than 7° as compared to ASCE 7-16. However, the change back to three zones greatly simplifies the figures. Figure 5 is an excerpt of Figure 30.3-2C in ASCE 7-16 and ASCE 7-22 and is annotated to provide specific pointers to the changes to the figure. Table 1 highlights the effect of these changes in ASCE 7-22 by providing examples of how the design wind pressure changes for a few select zones.



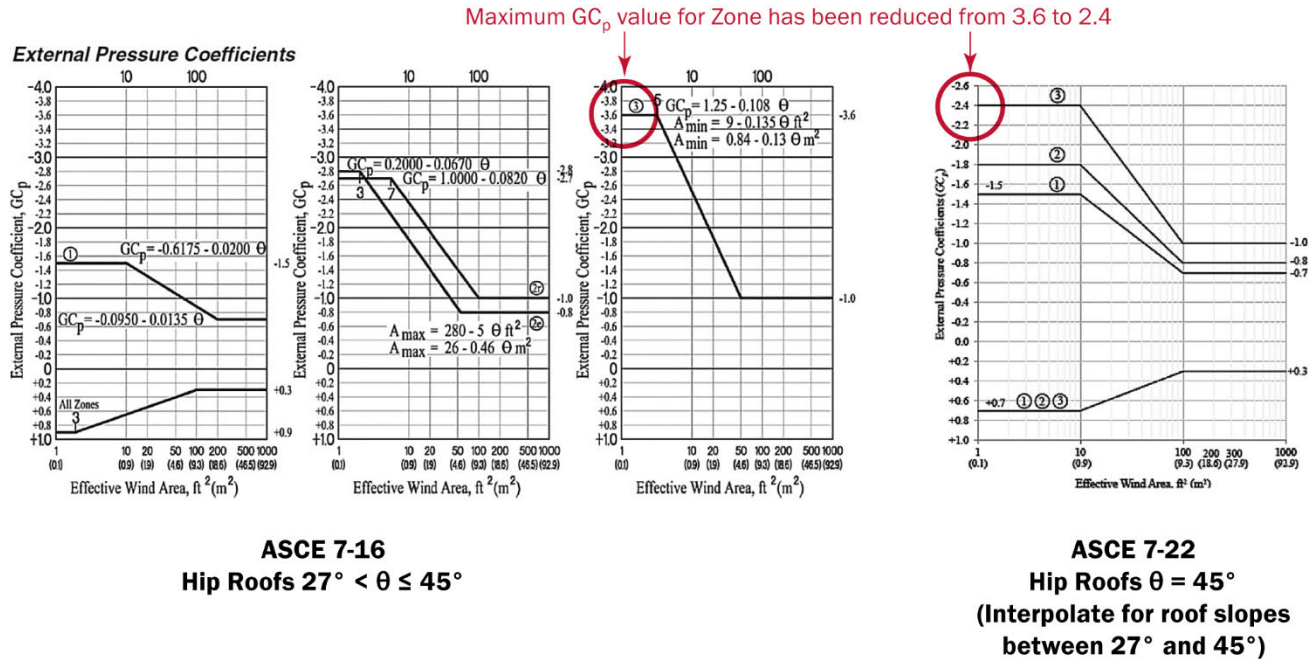
(Sources: ASCE 7-16 and ASCE 7-22)

Figure 5: Annotated excerpt of Figure 30.3-2C in ASCE 7-22 (Gable roofs, $20^\circ < \theta \leq 27^\circ$) as compared to ASCE 7-16

Table 1: Example Changes to Roof Component and Cladding Design Pressures for Enclosed Buildings

Zone	ASCE 7-16 GC_p	ASCE 7-22 GC_p	Design Pressure Change for Minimum Effective Wind Area
Gable roofs, $20^\circ < \theta \leq 27^\circ$			
3r (ASCE 7-16) 3 (ASCE 7-22)	-3.6	-3.0	-16%
Gable roofs, $27^\circ < \theta \leq 45^\circ$			
3e (ASCE 7-16) 3 (ASCE 7-22)	-3.2	-2.5	-21%

External pressure coefficients for hip roofs have been particularly simplified. The delineation of GC_p graphs based on h/B ratios for certain roof slopes has been deleted. Figure 6 provides a representative example of how the determination of external pressure coefficients for hip roofs has been simplified.



(Sources: ASCE 7-16 and ASCE 7-22)
Figure 6: Comparison of External Pressure Coefficients, GC_p , for Hip Roofs with $\theta > 27^\circ$ from Figure 30.3-2H in ASCE 7-16 and Figure 30.3-2G in ASCE 7-22

Separate graphs for roof overhang external pressure coefficients for gable and hip roofs with slopes $7^\circ < \theta \leq 45^\circ$ have been deleted. Roof overhang external pressure coefficients for these shapes are now addressed in Section 30.7 and are determined by the sum of the GC_p of the overhang's top and bottom surfaces determined by the applicable roof and wall external pressure coefficients. Figure 7 illustrates the determination of roof overhang external pressure coefficients, GC_p .

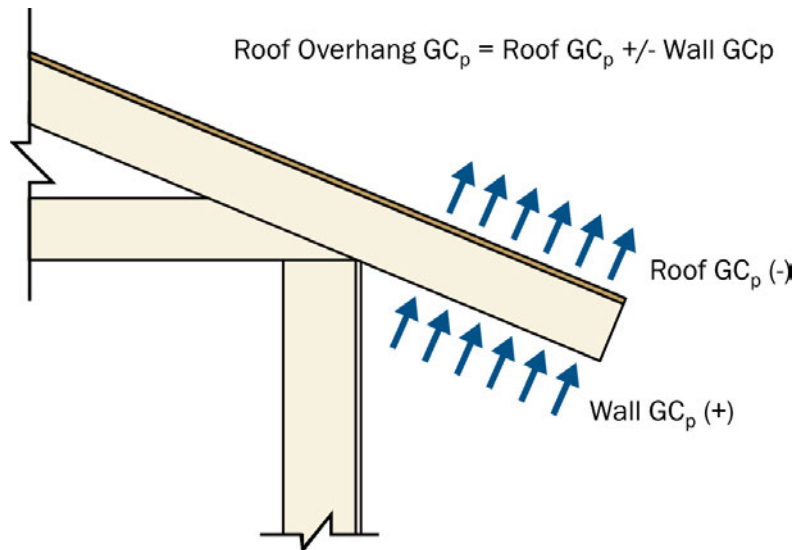


Figure 7: Determination of Roof Overhang GC_p

Other Changes to ASCE 7-22

See the References section for more information on the changes described in this fact sheet and for information on the summary of additional wind loading changes listed below:

- Deletion of the simplified methods (Chapters 27, 28, and 30)
- Revisions to the velocity pressure exposure coefficient, K_z (Section 26.10)
- New Chapter addressing tornado design (Chapter 32, See FEMA's ASCE 7-22 Tornado Loads Fact Sheet: TBD)
- New criteria for roof pavers (Section 30.12)
- New provisions for ground-mounted solar panels (Section 29.4.5)
- Adjustments to the topographic multiplier, K_{zt} (Section 26.8)
- New provisions for Main Wind Force Resisting System and Component and Cladding loads on elevated buildings (Sections 27.3.1.1 and 30.3.2.1)
- Revised wall external pressure coefficients, GC_p , for $h > 60$ feet (Section 30.4)
- New provisions for attached canopies on buildings with $h > 60$ feet (Section 30.9)
- Roof pressure zones for buildings with stepped flat roofs and heights ≤ 60 feet have been updated to reflect the appropriate flat roof pressure zones (Figure 30.3-3)
- New design wind speed maps that include topographic speedup effects have been added for Puerto Rico and the U.S. Virgin Islands. These mapped design wind speeds, as well as mapped design wind speeds for Hawaii which incorporated topographic speedup effects in ASCE 7-16, are only available through the ASCE 7 Hazard Tool (asce7hazardtool.online).

References

- ASCE. 2017. ASCE 7-16. *Minimum Design Loads and Associated Criteria for Buildings and Other Structures*. American Society of Civil Engineers.
- ASCE. 2021. ASCE 7-22. *Minimum Design Loads and Associated Criteria for Buildings and Other Structures*. American Society of Civil Engineers.

BEFORE THE PUBLIC UTILITY COMMISSION
OF OREGON

Docket PCN 5

In the Matter of

IDAHO POWER COMPANY'S
PETITION FOR CERTIFICATE OF PUBLIC CONVENIENCE
AND NECESSITY

Surrebuttal Testimony of Joseph Stippel

Exhibit 1902

Updated Oregon Building Code with October 2022 Amendments

April 7, 2023

2022 Oregon Structural Specialty Code adoption



Summary of amendments to the base codes

Effective: Oct. 1, 2022

The 2022 Oregon Structural Specialty Code (OSSC) became effective Oct. 1, 2022, with a 6-month phase-in period ending March 31, 2023. During the phase-in period, use of the 2019 OSSC or the 2022 OSSC is permitted.

The 2022 OSSC is based on the 2021 International Building Code (IBC) and the 2021 International Existing Building Code (IEBC) with integrated new construction provisions of the 2021 International Fire Code (IFC) and Oregon-specific amendments. The following is a summary of adopted amendments to the 2021 IBC and 2021 IEBC. This summary is intended to help with the transition from the previous edition and does not include all changes adopted in the 2022 OSSC.



The changes are denoted as follows:

- Blue/underline: Added language to the 2021 IBC or the 2021 IEBC in Chapter 34
- Orange/dotted underline: Added new construction provisions from the 2021 IFC
- ~~Red/strikethrough:~~ Deleted language from the 2021 IBC
- Pink/italics* Clarifying notes

Notes for Chapter 1: The entire chapter is included in this summary. Only added language to the IBC is highlighted. The deleted language has not been included.

Notes for Chapter 34: The adopted provisions of the IEBC are integrated as Chapter 34. The entire chapter is included in this summary. Only the added language to the IEBC is highlighted. The deleted language has not been included.

The following amendments were made throughout the 2021 IBC and 2021 IEBC and are not included in this summary:

References to	Changed to (unless otherwise indicated in this summary)
International Existing Building Code.....	Applicable sections of Chapter 34 of this code
International Mechanical Code.....	Applicable sections of the Oregon Mechanical Specialty Code
International Fuel Gas Code.....	Applicable sections of the Oregon Mechanical Specialty Code
International Energy Conservation Code.....	Applicable sections of the Oregon Energy Efficiency Specialty Code
International Residential Code.....	Applicable sections of the Oregon Residential Specialty Code
NFPA 70.....	Applicable sections of the Oregon Electrical Specialty Code
International Fire Code.....	Applicable sections of the Oregon Structural Specialty Code

For questions about the 2022 OSSC, visit the division website to [contact a building code specialist](#).

CHAPTER 1

SCOPE AND ADMINISTRATION

PART 1—SCOPE AND APPLICATION

SECTION 101 SCOPE AND GENERAL REQUIREMENTS

101.1 Title. These regulations shall be known as the *Oregon Structural Specialty Code* and may be cited as such and will be referred to herein as “this code.”

ORS 455.020 is not part of this code but is reprinted here for the reader’s convenience:

455.020 Purpose; scope of application; exceptions; scope of rules; fees by rule.

(1) This chapter is enacted to enable the Director of the Department of Consumer and Business Services to promulgate a state building code to govern the construction, reconstruction, alteration and repair of buildings and other structures and the installation of mechanical devices and equipment therein, and to require the correction of unsafe conditions caused by earthquakes in existing buildings. The state building code shall establish uniform performance standards providing reasonable safeguards for health, safety, welfare, comfort and security of the residents of this state who are occupants and users of buildings, and will provide for the use of modern methods, devices, materials, techniques and practicable maximum energy conservation.

101.2 Scope. The scope of this code is as provided in ORS 455.020(1).

This code as adopted by the State of Oregon, Building Codes Division, includes portions of the International Building Code, the International Fire Code, the International Existing Building Code and other nationally adopted codes.

It does not include provisions of the Oregon Fire Code adopted under the State Fire Marshal’s statutory authority. Unlike the Oregon Fire Code, the provisions of this code shall apply to the construction, reconstruction, alteration, repair and installation of materials and equipment in or a part of buildings and structures governed by the state building code.

Detached one- and two-family dwellings and townhouses not more than three stories above grade plane in height with a separate means of egress and their accessory structures shall comply with the Residential Code. See Section R101.2.1 for the scope and application of the Residential Code.

101.2.1 Optional local adoption to require a building permit. In addition to the work exempt from building permit in Section 105, the following matters are exempt from building permits unless specifically required by a municipality’s local ordinance. If a municipality adopts an ordinance to require a building permit for any of the items below, the construction standards of this code shall be applicable:

1. Protection of adjoining property.
2. Retaining walls. Statewide, retaining walls that provide safeguards for the users of buildings; support accessible parking; support a regulated building; or retain material, which if not restrained, could impact a regulated building, shall require a building permit.

A municipality may adopt an ordinance to regulate other retaining walls, provided that the threshold established for requiring a permit does not include retaining walls 4 feet (1219 mm) or less in height, measured from the bottom of the footing to the top of the wall, except where the retaining wall supports ascending slopes exceeding 3:1 (33 percent) or where the retaining wall supports a nonsoil surcharge. A local height threshold greater than 4 feet (1219 mm) is allowed.
3. Fences, other than required swimming pool barriers, constructed of wood, wire mesh or chain link. Statewide, fences serving as a swimming pool barrier, or as a portion of a swimming pool barrier, for swimming pools accessory to not more than four dwelling units shall require a building permit. A municipality may adopt an ordinance to regulate the construction of other fences constructed of wood, wire mesh or chain link, provided that the threshold established for requiring a building permit does not include fences that are 7 feet (2134 mm) or less in height. A municipality may adopt an ordinance to regulate fences constructed of materials other than wood, wire mesh or chain link, regardless of height. A local height threshold greater than 7 feet (2134 mm) is allowed, regardless of which materials are used.
4. Tanks that are located exterior to and not attached to or supported by a regulated building.
5. Cellular phone, radio, television and other telecommunication and broadcast towers that are not attached to or supported by a regulated building.
6. Flagpoles not attached to or supported by a regulated building. A local municipality may adopt an ordinance to require a permit for these structures provided that a permit is not required for these structures that are 25 feet (7620 mm) or less in height. A local height threshold greater than 25 feet (7620 mm) is allowed.
7. Ground-mounted photovoltaic systems. A local municipality may adopt an ordinance requiring a building permit for these structures, provided that a

permit is not required where these structures are 10 feet (3048 mm) or less in height measured to the highest point of the installation and no public access is permitted beneath the structures. A local height threshold greater than 10 feet (3048 mm) is allowed.

8. Signs not located in a public right-of-way, and not attached to or supported by a regulated building, which may include local adoption of Appendix H.
9. Fixed docks, piers or wharves with no super-structure.
10. Equipment shelters not intended for human occupancy with a *building area* of 250 square feet or less, designated as *Risk Category I or II*.
11. Unoccupied grain elevators and silos not exempted by ORS 455.315.
12. Rodentproofing, in accordance with Appendix F.
13. The design and construction of in-ground *swimming pools* accessory to not more than four *dwelling units*.

101.2.2 Matters not available for local regulation under the statutory authority of this code. While the following matters may be included in the published national model code, they may not be regulated by the local *municipality* under the statutory authority of this code. Any references to these matters retained in this code are for the convenience of the reader.

101.2.2.1 Matters outside the statutory authority of this code. The following matters are not regulated by this code and are outside the statutory authority of this code. Local *municipalities* may not regulate these matters under the authority of this code. A *municipality* may have authority outside of this code to regulate these matters locally, where not preempted:

1. Pursuant to the regulation of dangerous buildings, a *municipality* may adopt seismic rehabilitation plans that provide for phased completion of repairs that are designed to provide improved life safety but that may be less than the standards for new buildings.
2. Abatement of nuisances and dangerous buildings.
3. Portable fire extinguishers.
4. Fire safety during construction.
5. Public utility towers and poles.
6. Building or structure encroachments into the public right-of-way.
7. Demolition.
8. Hydraulic flood control structures, including but not limited to dams and levees.
9. Mechanical equipment not specifically regulated in the *state building code*.
10. Temporary use of streets, alleys and public property.
11. Floating structures.

12. Detached *tents* and other *membrane structures* erected for periods of 180 days or less.
13. Administration and implementation of a National Flood Insurance Program (NFIP).
14. Transitional housing accommodations.
15. Construction located in the public right-of-way.
16. Employee qualifications, in accordance with Appendix A.
17. Fire Districts, in accordance with Appendix D.
18. Flood-resistant Construction, in accordance with Appendix G.
19. Grading, in accordance with Appendix J.

101.2.2.2 Matters preempted by the state building code. The following matters and appendices are not adopted by the State of Oregon, Building Codes Division, as part of this code, but the referenced matters are preempted by the *state building code* and may not be adopted by a local *municipality*:

1. Appendix B (Board of Appeals).
2. Appendix E (Supplementary Accessibility Requirements).
3. Appendix K (Administrative Provisions).
4. Appendix L (Earthquake Recording Instrumentation).
5. Appendix M (Tsunami-generated Flood Hazard).
6. Appendix N (Replicable Buildings).

101.2.3 Appendices adopted. The following appendices are adopted as part of this code:

1. Appendix C (Agricultural Buildings).
2. Appendix I (Patio Covers).
3. Appendix O (Performance-based Application).

101.3 Purpose. The purpose of this code, as provided in ORS 455.020(1) and noted in Section 101.2, is to establish the minimum requirements to provide a reasonable level of safety, health and general welfare through structural strength, *means of egress*, stability, sanitation, light and ventilation, energy conservation, and for providing a reasonable level of life safety and property protection from the hazards of fire, *explosion* or *dangerous* conditions attributed to the built environment, and to provide a reasonable level of safety to fire fighters and emergency responders during emergency operations. It is not the purpose of this code to create or otherwise establish or designate any particular class or group of persons who will or should be especially protected or benefited by the terms of this code. Nothing in this code limits a local *municipality's* ability to require application of its own ordinances, or to enforce its own ordinances.

SECTION 102 APPLICABILITY

102.1 General. Where there is a conflict between a general requirement and a specific requirement, the specific

requirement shall be applicable. Where, in any specific case, different sections of this code specify different materials, methods of construction or other requirements, the most restrictive shall govern. Consistent with discretionary decision-making powers granted to building officials, a building official may take any action including but not limited to waiving a requirement, modifying a requirement or accepting an alternate method to the requirements of this code. When waiving a requirement or accepting a modification, a building official shall not allow a provision that would create an unsafe or dangerous condition regarding fire and life safety, and may not enforce requirements that are in addition to this code except where additional code requirements are specified by the terms of an alternate method approval.

102.1.1 Statutory references. This code is adopted pursuant to Oregon Revised Statutes (ORS). Where this code and the statutes specify different requirements, the statute shall govern. Statutes related to this code include, but are not limited to, ORS 455.010 through 455.895 and ORS 447.210 through 447.310.

Statutes referenced may be obtained from the Building Codes Division, 1535 Edgewater St. NW, Salem, OR 97304 or P.O. Box 14470, Salem, OR 97309 at a nominal cost or read online at: Oregon.gov/bcd.

102.2 Other laws. The provisions of this code shall not be deemed to nullify any provisions of local, state or federal law.

102.3 Application of references. References to chapter or section numbers, or to provisions not specifically identified by number, shall be construed to refer to such chapter, section or provision of this code.

102.4 Referenced codes and standards. The codes and standards referenced in this code shall be considered to be part of the requirements of this code to the prescribed extent of each such reference and as further regulated in Sections 102.4.1 and 102.4.2.

102.4.1 Conflicts. Where conflicts occur between provisions of this code and referenced codes and standards, the provisions of this code shall apply.

102.4.2 Provisions in referenced codes and standards. Where the extent of the reference to a referenced code or standard includes subject matter that is within the scope of this code, the provisions of this code shall take precedence over the provisions in the referenced code or standard.

OAR 918-008-0000 is not part of this code but is reprinted here for the readers' convenience:

918-008-0000 Purpose and Scope

(1) The Department of Consumer and Business Services, Building Codes Division, adopts model building codes, standards and other publications by reference, as necessary, through administrative rule to create the state building code. When a matter is included in a specialty code or referenced publication that is in conflict with Oregon Revised Statutes or Oregon Administrative Rules, the statute or rule applies and the code or standard provision does not. All remaining parts or application of the code or standard remain in effect.

(2) Unless required by law, matters generally not authorized for inclusion in a specialty code or referenced standard include, but are not limited to: licensing or certification requirements, or other qualifications and standards for businesses or workers; structures or equipment maintenance requirements; matters covered by federal or state law; and matters that conflict with other specialty codes or publications adopted by the department.

(3) OAR 918-008-0000 to OAR 918-008-0070 provides the process for adopting and amending the state building code that is consistent across all program areas.

(4) The state building code is derived from the most appropriate version of base model codes, which are updated periodically.

(5) The Oregon specialty code amendment process begins approximately midway into a code cycle.

(6) An appropriate advisory board approves or forwards the adoption of the Oregon specialty code and amendments to the Department for adoption.

(7) Notwithstanding sections (3) through (6) of this rule, the division may adopt supplemental code amendments as authorized by OAR 918-008-0028.

102.4.3 ASCE Standard 24, Flood Resistant Design and Construction. The following ASCE 24 tables are not adopted as part of this code, as the subject matter encompasses *Freeboard, Base Flood Elevation and Design Flood Elevation*. The authority to establish the same is reserved for local government.

1. Table 2-1, *Minimum elevation of the top of lowest floor.*
2. Table 4-1, *Minimum elevation of bottom of lowest supporting horizontal structural member of lowest floor.*
3. Table 5-1, *Minimum elevation below which flood damage-resistant materials shall be used.*
4. Table 6-1, *Minimum elevation of floodproofing.*
5. Table 7-1, *Minimum elevation of attendant utilities and equipment.*

National Flood Insurance Program (NFIP).

Each local community participating in the National Flood Insurance Program (NFIP) designates a local flood plain administrator who is responsible to make sure communities meet their insurance program obligations. Certain matters comprised within the NFIP program may conflict with or overlap with the state building code. Certain decisions such as sill plate height and other NFIP criteria fall under the authority and responsibility of the flood plain administrator. Once decisions under the NFIP program are made, then the appropriate requirements of this code for the construction of the building are applied.

Local communities may choose to designate their local building official as the flood plain administrator or may designate other staff. When a building official functioning in the capacity of flood plain administrator exercises authority under the NFIP, such decisions are not part of this code nor subject to the building official duties and responsibilities as adopted by the State of Oregon, Building Codes Division.

Per ORS 455.210(3)(c), local municipalities are prohibited from using building permit monies for any matter other than administration and enforcement of the state building code. Administration and implementation of a local NFIP program are not part of the state building code.

102.5 Partial invalidity. In the event that any part or provision of this code is held to be illegal or void, this shall not have the effect of making void or illegal any of the other parts or provisions.

102.6 Existing structures. The legal occupancy of any structure existing on the date of adoption of this code shall be permitted to continue without change, except as otherwise specifically provided in this code.

102.6.1 Existing building regulation. The repair, alteration, change of occupancy, addition and relocation of existing buildings, regardless of occupancy, shall comply with Chapter 34 of this code.

102.6.2 Local seismic rehabilitation plans. See ORS 455.020 (4).

ORS 455.020 (4) is not part of this code but is reprinted here for the readers' convenience:

455.020 Purpose; scope of application; exceptions; scope of rules; fees by rule.

(4) This chapter and any specialty code does not limit the authority of a municipality to enact regulations providing for local administration of the state building code; local appeal boards; fees and other charges; abatement of nuisances and dangerous buildings; enforcement through penalties, stop-work orders or other means; or minimum health, sanitation and safety standards for governing the use of structures for housing, except where the power of municipalities to enact any such regulations is expressly withheld or otherwise provided for by statute. Pursuant to the regulation of dangerous buildings, a municipality may adopt seismic rehabilitation plans that provide for phased completion of repairs that are designed to provide improved life safety but that may be less than the standards for new buildings.

PART 2—ADMINISTRATION AND ENFORCEMENT

**SECTION 103
CODE COMPLIANCE AGENCY**

Not adopted by the state of oregon, building codes division, as part of this code.

**SECTION 104
DUTIES AND POWERS OF BUILDING OFFICIAL**

The requirements of Sections 104.1 and 104.3 shall apply unless specifically amended by a local municipality under the authority of ORS 455.020.

104.1 General. The *building official* is hereby authorized and directed to enforce the provisions of this code. The *building official* shall have the authority to render interpretations of this code and to adopt policies and procedures in order to clarify the application of its provisions. Consistent with discretionary decision-making powers granted to building officials, a building official may take any action including but not limited to waiving a requirement, modifying a requirement or accepting an alternate method to the requirements of this code. When waiving a requirement or accepting a modification, a building official shall not allow a provision that would create an unsafe or dangerous condition regarding fire and life safety, and may not enforce requirements that are in addition to this code except where additional code requirements are specified by the terms of an alternate method approval.

104.2 Applications and permits. The *building official* shall receive applications, review *construction documents* and issue *permits* for the erection, and *alteration*- and moving of buildings and structures, inspect the premises for which such *permits* have been issued and enforce compliance with the provisions of this code.

104.2.1 Determination of substantially improved or substantially damaged existing buildings and structures in flood hazard areas. For applications for reconstruction, rehabilitation, *repair*, *alteration*, *addition* or other improvement of existing buildings or structures located in *flood hazard areas* established by the flood plain administrator, the flood plain administrator shall determine if the proposed work constitutes substantial improvement or *repair of substantial damage*. Where the flood plain administrator determines that the proposed work constitutes *substantial improvement* or *repair of substantial damage*, and where required by this code, the *building official* shall require the building to meet the requirements of Section 1612.

104.3 Notices and orders. The *building official* shall issue necessary notices or orders to ensure compliance with this code.

104.4 Inspections. The *building official* shall make the required inspections, or the *building official* shall have the authority to accept reports of inspection by *approved agencies* or individuals. Reports of such inspections shall be in writing and be certified by a responsible officer of such *approved agency* or by the responsible individual. The *building official* is authorized to engage such expert opinion as deemed necessary to report on unusual technical issues that arise, subject to the approval of the appointing authority.

104.5 Right of entry. This section is not adopted by the State of Oregon, Building Codes Division, as part of this code.

104.6 Department records. The *building official* shall keep official records according to the applicable retention requirements set forth in OAR 166-150-0020 for locations where the county has jurisdiction, in OAR 166-200-0250 for locations where a city has jurisdiction, and in OAR 166 Division 300, for locations where the State of Oregon has jurisdiction. The *building official* shall maintain a permanent record of all permits issued in flood hazard areas, including copies of inspection reports and certifications required in Section 1612.

104.7 Liability. See ORS 30.265 for regulations relating to liability.

104.8 Approved materials and equipment. Materials, equipment and devices *approved* by the *building official* shall be constructed and installed in accordance with such approval.

104.8.1 Used materials and equipment. Used materials, equipment and devices shall not be reused unless approved by the *building official*. Used or salvaged dimensional lumber shall be permitted to be used.

104.9 Modifications. Where there are practical difficulties involved in carrying out the provisions of this code, the *building official* shall have the authority to grant modifications for individual cases, upon application of the *owner* or the *owner's* authorized agent, provided that the *building official* shall first find that special individual reason makes the strict letter of this code impractical, the modification is in compliance with the intent and purpose of this code and that such modification does not create an unsafe or dangerous condition regarding fire and life safety, and does not enforce requirements that are in addition to the state building code except where additional code requirements are specified by the terms of an alternate method approval. The details of action granting modifications shall be recorded and entered in the files of the *municipality*.

104.9.1 Flood hazard areas. This section is not adopted by the State of Oregon, Building Codes Division, as part of this code. The *building official* shall not grant modifications to any provision required in *flood hazard areas* as established by Section 1612.3 unless a determination has been made that:

1. A showing of good and sufficient cause that the unique characteristics of the size, configuration or topography of the site render the elevation standards of Section 1612 inappropriate.

2. A determination that failure to grant the variance would result in exceptional hardship by rendering the lot undevelopable.
3. A determination that the granting of a variance will not result in increased flood heights, additional threats to public safety, extraordinary public expense, cause fraud on or victimization of the public, or conflict with existing laws or ordinances.
4. A determination that the variance is the minimum necessary to afford relief, considering the flood hazard.
5. Submission to the applicant of written notice specifying the difference between the *design flood elevation* and the elevation to which the building is to be built, stating that the cost of flood insurance will be commensurate with the increased risk resulting from the reduced floor elevation, and stating that construction below the *design flood elevation* increases risks to life and property.

104.10 Alternative materials, design and methods of construction and equipment. The provisions of this code are not intended to prevent the installation of any material or to prohibit any design or method of construction not specifically prescribed by this code, provided that any such alternative has been *approved*. An alternative material, design or method of construction shall be *approved* where the *building official* finds that the proposed alternative meets all of the following:

1. The alternative material, design or method of construction is satisfactory and complies with the intent of the provisions of this code.
2. The material, method or work offered is, for the purpose intended, not less than the equivalent of that prescribed in this code as it pertains to the following:
 - 2.1. Quality.
 - 2.2. Strength.
 - 2.3. Effectiveness.
 - 2.4. Fire resistance.
 - 2.5. Durability.
 - 2.6. Safety.

Where the alternative material, design or method of construction is not *approved*, the *building official* shall respond in writing, stating the reasons why the alternative was not *approved*.

104.10.1 Research reports. Supporting data, where necessary to assist in the approval of materials or assemblies not specifically provided for in this code, shall consist of valid research reports from *approved* sources.

104.10.2 Tests. Whenever there is insufficient evidence of compliance with the provisions of this code, or evidence that a material or method does not conform to the requirements of this code, or in order to substantiate claims for alternative materials or methods, the *building official* shall have the authority to require tests as evidence of compliance to be made without expense to the *municipality*. Test methods shall be as specified in this

code or by other recognized test standards. In the absence of recognized and accepted test methods, the *building official* shall approve the testing procedures. Tests shall be performed by an *approved agency*. Reports of such tests shall be retained by the *building official* for the period required for retention of public records.

SECTION 105 PERMITS

105.1 Required. Any *owner* or owner's authorized agent who intends to construct, enlarge, alter, *repair*, move, - or change the occupancy of a building or structure,- which is regulated by this code, or to cause any such work to be performed, shall first make application to the *building official* and obtain the required *permit*. Any owner or owner's authorized agent who intends to repair an existing fire protection system or life safety system shall first notify the local building official and obtain any necessary building permit, where required by the municipality. See ORS 455.020(2).

Exceptions:

1. Construction subject to minor labels and master permits when authorized by the inspection authority under OAR Chapter 918, Division 100.
2. Temporary (180 days) structural supports, structural replacement or repairs performed in an emergency on an existing structure. The municipality shall be notified of this work within 72 hours and permit application for the temporary work shall be submitted within the next five business days.

105.2 Work exempt from permit. For the application and scope of this code, see Section 101. For repairs in existing buildings, see Chapter 34. *Permits* shall not be required for the following:

Building:

1. One-story detached *nonoccupied accessory structures*, provided that the floor area is not greater than 120 square feet (11 m²).
2. Platforms, sidewalks and driveways not more than 30 inches (762 mm) above adjacent grade, and not over any basement or story below and are not part of an accessible route.
3. Painting, papering, tiling, carpeting, cabinets, counter tops and similar finish work.
4. Shade cloth structures constructed for nursery or agricultural purposes, not including service systems.
5. Window awnings in Group R-3 and U occupancies, supported by an exterior wall that do not project more than 54 inches (1372 mm) from the *exterior wall* and do not require additional support.
6. Nonfixed and movable fixtures, cases, racks, counters and partitions not over 5 feet 9 inches (1753 mm) in height.
7. Farm and forest use agricultural buildings exempted in ORS 455.315 (also see Appendix C).

8. Buildings and facilities exempted in ORS 455.315.

Note: Unless otherwise exempted, separate plumbing, electrical and mechanical permits may be required for the exempted items listed in this section. Additionally, all new construction and substantial improvements (including the placement of prefabricated buildings and certain building work exempt from permit under Section 105.2) shall be designed and constructed with methods, practices and materials that minimize flood damage in accordance with this code.

The requirements of Sections 105.3 through 105.6 shall apply unless specifically amended by a local municipality under the authority of ORS 455.020.

105.3 Application for permit. To obtain a *permit*, the applicant shall first file an application therefor in writing on a form furnished by the *municipality* for that purpose. Such application shall:

1. Identify and describe the work to be covered by the *permit* for which application is made.
2. Describe the land on which the proposed work is to be done by legal description, street address or similar description that will readily identify and definitely locate the proposed building or work.
3. Indicate the use and occupancy for which the proposed work is intended.
4. Be accompanied by *construction documents* and other information as required in Section 107.
5. State the valuation of the proposed work.
6. Be signed by the applicant, or the applicant's authorized agent.
7. Give such other data and information as required by the *building official*.

105.3.1 Action on application. The *building official* shall examine or cause to be examined applications for *permits* and amendments thereto within a reasonable time after filing. If the application or the *construction documents* do not conform to the requirements of pertinent laws, the *building official* shall reject such application in writing, stating the reasons therefor. If the *building official* is satisfied that the proposed work conforms to the requirements of this code and laws - applicable thereto, the *building official* shall issue a *permit* therefor as soon as practicable. Nothing in this code limits a local municipality's ability to require application of its own ordinances, or to enforce its own ordinances.

105.3.2 Time limitation of application. An application for a *permit* for any proposed work shall be deemed to have been abandoned 180 days after the date of filing, unless such application has been pursued in good faith or a *permit* has been issued; except that the *building official* is authorized to grant one or more extensions of time for additional periods not exceeding 90 days each. The extension shall be requested in writing and justifiable cause demonstrated.

105.4 Validity of permit. The issuance or granting of a *permit* shall not be construed to be a *permit* for, or an approval of, any violation of any of the provisions of this code or of any other [laws](#). *Permits* presuming to give authority to violate or cancel the provisions of this code or other [laws](#) shall not be valid. The issuance of a *permit* based on *construction documents* and other data shall not prevent the *building official* from requiring the correction of errors in the *construction documents* and other data. The *building official* is authorized to prevent occupancy or use of a structure where in violation of this code or of any other [laws](#). [Nothing in this code limits a local municipality's ability to require application of its own ordinances, or to enforce its own ordinances.](#)

105.5 Expiration. Every *permit* issued shall become invalid unless the work on the site authorized by such *permit* is commenced within 180 days after its issuance, or if the work authorized on the site by such *permit* is suspended or abandoned for a period of 180 days after the time the work is commenced. The *building official* is authorized to grant, in writing, one or more extensions of time, for periods not more than 180 days each. The extension shall be requested in writing and justifiable cause demonstrated.

105.6 Suspension or revocation. The *building official* is authorized to suspend or revoke a *permit* issued under the provisions of this code wherever the *permit* is issued in error or on the basis of incorrect, inaccurate or incomplete information, or in violation of any of the provisions of this code. [Nothing in this code limits a local municipality's ability to require application of its own ordinances, or to enforce its own ordinances.](#)

105.7 Placement of permit. The building *permit* or copy shall be kept on the site of the work until the completion of the project. [The building official may adopt local policies approving specific permit and inspection recording methods.](#)

SECTION 106 FLOOR AND ROOF DESIGN LOADS

106.1 Live loads posted. In commercial or industrial buildings, for each floor or portion thereof designed for *live loads* exceeding 50 psf (2.40 kN/m²), such design *live loads* shall be conspicuously posted by the owner or the owner's authorized agent in that part of each *story* in which they apply, using durable signs. It shall be unlawful to remove or deface such notices.

106.2 Issuance of certificate of occupancy. A certificate of occupancy required by Section 111 shall not be issued until the floor load signs, required by Section 106.1, have been installed.

106.3 Restrictions on loading. It shall be unlawful to place, or cause or permit to be placed, on any floor or roof of a building, structure or portion thereof, a load greater than is permitted by this code.

SECTION 107 CONSTRUCTION DOCUMENTS

107.1 General. Submittal documents consisting of *construction documents*, statement of *special inspections*, geotechnical report and other data shall be submitted in two or more sets, or in a digital format where [specified by the municipality](#), with each *permit* application. [Where special conditions exist, the building official is authorized to require additional construction documents be submitted.](#) The *construction documents* shall be prepared by a *registered design professional* where required by [ORS 671 and 672](#).

Exceptions:

1. The *building official* [may](#) waive the submission of [plans, calculations, construction inspection requirements](#) and other data [and the related plan review fee](#) if it is found that the nature of the work applied for is such that review of [plans](#) is not necessary to obtain compliance with this code.
2. [Plans, specifications, calculations, diagrams and other data prepared and designed by an engineer or architect licensed by the state to practice as such are not required for the following work:](#)
 - 2.1. [The erection, enlargement or alteration of any building, or any appurtenance thereto, where the resulting building has a ground area of 4,000 square feet \(372 m²\) or less and is not more than 20 feet \(6096 mm\) in height from the top surface of the lowest floor to the highest interior overhead finish \(see ORS 671.030\).](#)
 - 2.2. [A detached single-family dwelling; farm agricultural building; nonfarm agricultural building; or accessory building to a single-family dwelling, farm agricultural building, or nonfarm agricultural building.](#)
 - 2.3. [Alterations or repairs that do not involve the structural parts of the building.](#)

107.2 Construction documents. *Construction documents* shall be in accordance with Sections 107.2.1 through 107.2.8.

107.2.1 Information on construction documents. *Construction documents* shall be dimensioned and drawn on suitable material. Electronic media documents are permitted to be submitted where *approved* by the *building official*. *Construction documents* shall be of sufficient clarity to indicate the location, nature and extent of the work proposed and show in detail that it will conform to the provisions of this code and relevant laws-. [Nothing in this code limits a local municipality's ability to require application of its own ordinances, or to enforce its own ordinances.](#)

107.2.2 Fire protection system shop drawings. Shop drawings, [plans, specifications or sketches](#) for the *fire protection systems* shall be submitted to [the building official pursuant to the requirements of the state building code](#) and [ORS Chapter 455 or ORS 479.155 to determine compliance with the state building code, including but not](#)

limited to fire and life safety standards that are part of the state building code. Shop drawings, plans, specifications or sketches shall be *approved* prior to the start of system installation. Shop drawings shall contain all information as required by the referenced installation standards in Chapter 9. The issuance of permits and inspections shall be the authority of the building official to administer under ORS Chapter 455.

107.2.3 Means of egress. The *construction documents* shall show in sufficient detail the location, construction, size and character of all portions of the *means of egress* including the path of the *exit discharge* to the *public way* in compliance with the provisions of this code. In other than occupancies in Groups R-2, R-3, and I-1, the *construction documents* shall designate the number of occupants to be accommodated on every floor, and in all rooms and spaces.

107.2.4 Exterior wall envelope. *Construction documents* for all buildings shall describe the *exterior wall envelope* in sufficient detail to determine compliance with this code. The *construction documents* shall provide details of the *exterior wall envelope* as required, including flashing, intersections with dissimilar materials, corners, end details, control joints, intersections at roof, eaves or parapets, means of drainage, water-resistive barrier and details around openings.

The *construction documents* shall include manufacturer's installation instructions that provide supporting documentation that the proposed penetration and opening details described in the *construction documents* maintain the weather resistance of the *exterior wall envelope*. The supporting documentation shall fully describe the *exterior wall* system that was tested, where applicable, as well as the test procedure used.

107.2.5 Exterior balconies and elevated walking surfaces. Where balconies or other elevated walking surfaces have *weather-exposed surfaces*, and the structural framing is protected by an impervious moisture barrier, the *construction documents* shall include details for all elements of the impervious moisture barrier system. The *construction documents* shall include manufacturer's installation instructions.

107.2.6 Site plan. The *construction documents* submitted with the application for *permit* shall be accompanied by a site plan showing to scale the size and location of new construction and existing structures on the site, distances from *lot lines*, the established street grades and the proposed finished grades and— it shall be drawn in accordance with an accurate boundary line survey.— The *building official* is authorized to waive or modify the requirement for a site plan where the application for *permit* is for *alteration* or *repair* or where otherwise warranted.

107.2.7 Structural information. The *construction documents* shall provide the information specified in Section 1603.

107.3 Examination of documents. The *building official* shall examine or cause to be examined the accompanying submittal documents and shall ascertain by such examinations whether the construction indicated and described is in accordance with the requirements of this code and other pertinent laws. Nothing in this code limits a local municipality's ability to require application of its own ordinances, or to enforce its own ordinances.

107.3.1 Approval of construction documents. When the *building official* issues a *permit*, the *construction documents* shall be *approved*, in writing or by stamp, as "Reviewed for Code Compliance." One set of *construction documents* so reviewed shall be retained by the *building official*. The other set shall be returned to the applicant, shall be kept at the site of work and shall be open to inspection by the *building official* or a duly authorized representative. Construction documents shall be approved in the timelines specified in ORS 455.467.

107.3.2 Previous approvals. This code shall not require changes in the *construction documents*, construction or designated occupancy of a structure for which a lawful *permit* has been heretofore issued or otherwise lawfully authorized, and the construction of which has been pursued in good faith within 180 days after the effective date of this code and has not been abandoned.

107.3.3 Phased approval. The *building official* is authorized to issue a *permit* for the construction of foundations or any other part of a building or structure before the *construction documents* for the whole building or structure have been submitted, provided that adequate information and detailed statements have been filed complying with pertinent requirements of this code. The holder of such *permit* for the foundation or other parts of a building or structure shall proceed at the holder's own risk with the building operation and without assurance that a *permit* for the entire structure will be granted.

107.3.4 Design professional in responsible charge. Where it is required that documents be prepared by a *registered design professional*, the *building official* shall be authorized to require the *owner* or the *owner's* authorized agent to engage and designate on the building *permit* application a *registered design professional* who shall act as the *registered design professional in responsible charge*. If the circumstances require, the *owner* or the *owner's* authorized agent shall designate a substitute *registered design professional in responsible charge* who shall perform the duties required of the original *registered design professional in responsible charge*. The *building official* shall be notified in writing by the *owner* or the *owner's* authorized agent if the *registered design professional in responsible charge* is changed or is unable to continue to perform the duties.

The *registered design professional in responsible charge* shall be responsible for reviewing and coordinating submittal documents prepared by others, including phased and deferred submittal items, for compatibility with the design of the building.

107.3.4.1 Deferred submittals. Deferral of any submittal items shall have the prior approval of the building official. The registered design professional in responsible charge shall list the deferred submittals on the construction documents for review by the building official.

Documents for deferred submittal items shall be submitted to the registered design professional in responsible charge who shall review them and forward them to the building official with a notation indicating that the deferred submittal documents have been reviewed and found to be in general conformance to the design of the building. The deferred submittal items shall not be installed until the deferred submittal documents have been approved by the building official. See ORS 455.467(3).

Two copies of a plot plan for the occupancies listed in this section shall be submitted for the placing of prefabricated structures to show the relationship of all adjacent buildings and their exit ways.

ORS 455.467(1) & (2) are not part of this code but are reprinted here for the reader's convenience:

455.467 Timelines for approval or disapproval of certain specialty code building plans; exceptions; phased permit systems; failure to adhere to timelines.

(1) Except as provided in subsection (2) of this section, for specialty code plan reviews of simple low-rise residential dwellings, the Department of Consumer and Business Services or a municipality that administers a building inspection program under ORS 455.148 or 455.150 shall approve or disapprove the specialty code building plan:

(a) For a jurisdiction with a population that is less than 300,000, within 10 business days of receiving a complete application, or shall implement the process described in ORS 455.465.

(b) For a jurisdiction with a population that is 300,000 or more, shall implement the process described in ORS 455.465.

(2) The 10-day and 15-day requirements in subsection (1) of this section do not apply if:

(a) The plan requires approval by federal, state or local agencies outside the jurisdiction of the issuing agency;

(b) The plan is for a complex structure that requires additional review as determined by the department or municipality; or

(c) Based on conditions that exist in the affected municipality, the Director of the Department of Consumer and Business Services authorizes a different plan review schedule as described in a building inspection program submitted under ORS 455.148 or 455.150.

(3) For specialty code plan reviews of commercial structures, a municipality shall include in its building inspection program submitted under ORS 455.148 or 455.150 a process for plan review services. The municipality shall include in its program detailed reasons supporting the proposed plan review process. The plan review services provided by the municipality shall:

(a) Allow an applicant to defer the submittal of plans for one or more construction phases for a commercial construction project in accordance with the state building code; and

(b) Allow an applicant to receive permits for each of the phases of a commercial construction project as described in the state building code when the plan review for that phase is approved.

(4) For a phased commercial construction project as described in subsection (3) of this section, the municipality shall inform the applicant of the detailed plans necessary for each phase of the project and the estimated time for initial and phased review of the building plans for conformance with the state building code.

(5) An applicant submitting plans under subsection (3) of this section is responsible for ensuring that the project meets all specialty code requirements and that the project does not proceed beyond the level of approval authorized by the building official.

(6) A municipality that repeatedly fails to meet the plan review period described in this section or otherwise authorized in its building inspection program submitted under ORS 455.148 or 455.150 shall be considered to be engaging in a pattern of conduct of failing to provide timely plan reviews under ORS 455.160. [1999 c.1045 §21; 2001 c.384 §1; 2001 c.573 §13; 2003 c.675 §28]

107.3.5 Fire and life safety plan review, occupancies to be reviewed. ORS 479.155(2) requires submission of plans for review and approval of certain occupancies.

Unless exempted by the Building Codes Division through delegation of the fire and life safety plan review program, the owner shall submit to the building codes administrator two copies (or, where required, an additional copy shall be submitted for local government use) of a plan or sketch drawn clearly and to scale showing information as set forth in Section 107.3.5.1 for review and approval prior to beginning construction or alteration. Fire and life safety plan review is required for the following occupancies:

1. Group A occupancies.
2. Group B occupancies over 4,000 square feet (372 m²) or more than 20 feet (6096 mm) in height, or with a basement.
3. Group E occupancies.
4. Group F occupancies over 4,000 square feet (372 m²) or more than 20 feet (6096 mm) in height, or with a basement.
5. Group H occupancies over 1,500 square feet (139 m²) or more than 20 feet (6096 mm) in height, or with a basement.
6. Group I occupancies.
7. Group M occupancies over 4,000 square feet (372 m²) or more than 20 feet (6096 mm) in height, or with a basement.
8. Group R, Division 1, 2 and 4 occupancies over 4,000 square feet (372 m²) or more than 20 feet (6096 mm) in height, or with a basement over 1,500 square feet (139 m²).
9. Group S, Division 1, 2 and 3 occupancies over 4,000 square feet (372 m²) or more than 20 feet (6096 mm) in height, or with a basement.

10. Group U occupancies over 4,000 square feet (372 m²) or more than 20 feet (6096 mm) in height, or with a basement.

ORS 479.155(2) is not part of this code but is reprinted here for the reader's convenience:

479.155 Plan of proposed construction or alteration; declaration of value; approval of plan; effect of approval; rules.

(2) Prior to construction or alteration of a hospital, public building as defined in ORS 479.168, public garage, dry cleaning establishment, apartment house, hotel, bulk oil storage plant, school, institution as defined in ORS 479.210, or any other building or structure regulated by the State Fire Marshal for use and occupancy or requiring approval by the State Fire Marshal pursuant to statute, the owner shall submit to the director two copies of a plan or sketch showing the location of the building or structure with relation to the premises, distances, lengths and details of construction as the director shall require. A filing is not required with respect to any such building or structure in any area exempted by order of the State Fire Marshal pursuant to ORS 476.030. Approval of the plans or sketches by the director is considered approval by the State Fire Marshal and satisfies any statutory provision requiring approval by the State Fire Marshal.

107.3.5.1 Fire and life safety plan review limits. The following portions of this code shall be used to review the plans submitted under this subsection. (These requirements are not intended to apply to structural, architectural, light and ventilation, accessibility and energy conservation requirements of the code except as they affect requirements included on the list.)

Chapters 1 through 10.

Chapter 11 (egress).

Chapter 14.

Chapter 15.

Chapter 24.

Chapter 26.

Chapters 30 through 32.

Chapter 34.

Appendix C.

107.4 Amended construction documents. Work shall be installed in accordance with the *approved construction documents*, and any changes made during construction that are not in compliance with the *approved construction documents* shall be resubmitted for approval as an amended set of *construction documents*.

107.5 Retention of construction documents. One set of *approved construction documents* shall be retained by the *building official* for a period of not less than dictated by OAR 166-150-0020 where a county has jurisdiction; OAR 166-200-0250 where the city has jurisdiction; and OAR 166 Division 300, where the State of Oregon has jurisdiction. One set of approved plans and specifications shall be returned to the applicant and said set shall be kept on the site of the building or work at all times during which the work authorized thereby is in progress.

ORS 455.020(2) is not part of this code but is reprinted here for the reader's convenience:

455.020(2) Purpose; scope of application; exceptions; scope of rules; fees by rule.

(2) The rules adopted pursuant to this chapter shall include structural standards; standards for the installation and use of mechanical, heating and ventilating devices and equipment; and standards for prefabricated structures; and shall, subject to ORS 455.210, prescribe reasonable fees for the issuance of building permits and similar documents, inspections and plan review services by the Department of Consumer and Business Services. The department may also establish, by rule, the amount of any fee pertaining to the state building code or any specialty code that is authorized by statute, but for which an amount is not specified by statute.

SECTION 108

TEMPORARY STRUCTURES AND USES

108.1 General. The *building official* is authorized to issue a *permit* for temporary structures and temporary uses. Such *permits* shall be limited as to time of service, but shall not be permitted for more than 180 days. The *building official* is authorized to grant extensions for demonstrated cause. See Chapter 31 for additional requirements. Tents and other membrane structures erected for a period of less than 180 days are regulated by the fire official.

108.2 Conformance. Temporary structures and uses shall comply with the requirements in Section 3103.

108.3 Termination of approval. The *building official* is authorized to terminate such *permit* for a temporary structure or use and to order the temporary structure or use to be discontinued.

SECTION 109

FEES

The requirements of Section 109 shall apply unless specifically amended by a *municipality* under the authority of ORS 455.020.

109.1 Payment of fees. A *permit* shall not be valid until the fees prescribed by law have been paid, nor shall an amendment to a *permit* be released until the additional fee, if any, has been paid.

109.2 Schedule of permit fees. Where a *permit* is required, a fee for each *permit* shall be paid as required, in accordance with the schedule as established by the *municipality*, under authority of ORS 455.020 and 455.210 or as set forth in OAR Chapter 918, Division 460, where the State of Oregon has jurisdiction.

ORS 455.210(3)(a) is not part of this code but is reprinted for the reader's convenience:

ORS 455.210 Fees; appeal of fees; surcharge; reduced fees; rules.

(3)(a) A municipality may adopt by ordinance or regulation such fees as may be necessary and reasonable to provide for the administration and enforcement of any specialty code or codes for which the municipality has assumed responsibility under ORS 455.148 or 455.150. A municipality shall give the director notice of the proposed adoption of a new or increased fee under this subsection. The municipality shall give the notice to the director at the time the municipality provides the opportunity for public comment under ORS 294.160 regarding the fee or, if the proposed fee is contained in an estimate of municipal budget resources, at the time notice of the last budget meeting is published under ORS 294.426.

109.2.1 Plan review fees. Where *construction documents* are required by Section 107.1, a plan review fee shall be paid at the time of submittal. The plan review fee shall be a percentage of the building permit fee as established under Section 109.2. Additionally, the fee for a fire and life safety plan review, as required by Section 107.3.5, shall be a percentage of the building permit fee established under Section 109.2.

The plan review fees specified in this section are separate from the permit fees specified in Section 109.2 and are in addition to the permit fees. The state surcharge is not applied to plan review fees.

Where submitted *construction documents* are incomplete or changed so as to require additional plan review, a fee shall be charged according to the rate established by the *municipality*. Where the project includes deferred submittals, as defined in Section 107.3.4.2, an additional plan review fee shall be charged according to the rate established by the *municipality* in accordance with OAR 918-050-0170.

109.3 Building permit valuations. Structural building permit valuations shall be based on the Uniform Fee Methodologies established by OAR 918-050-0100.

Exception: Work exempted by Section 105.2.

OAR 918-050-0100 is not part of this code but is reprinted here for the reader's convenience.

Uniform Fee Methodology

918-050-0100 Statewide Fee Methodologies for Residential and Commercial Permits

(2) Commercial construction permit fees shall be calculated using the following methodologies:

(a) A plumbing permit fee shall be calculated based on the number of fixtures and footage of piping, with a set minimum fee.

(b) A mechanical permit fee shall be calculated based on the value of the mechanical equipment and installation costs and applied to the municipality's fee schedule with a set minimum fee.

(c) A structural permit fee shall be calculated by applying the valuation to the municipality's fee schedule with a minimum set fee. Valuation shall be the greater of either:

(A) The valuation based on the ICC Building Valuation Data Table current as of April 1 of each year, using the occupancy and construction type as determined by the building official, multiplied by the square footage of the structure; or (B) The value as stated by the applicant. (C) When the construction or occupancy type does not fit the ICC Building Valuation Data Table, the valuation shall be determined by the building official with input from the applicant.

109.4 Work commencing before permit issuance. Any person who commences any work before obtaining the necessary *permits* shall be subject to an *investigation fee*. The amount of the investigative fee shall be the average or actual additional cost of ensuring that a building ~~or~~ structure is in conformance with this code and shall be in addition to the required *permit* fees.

ORS 455.058 is not part of this code but is reprinted here for the reader's convenience:

455.058 Investigation fee for work commenced without permit; rules.

(1) Except as provided in subsection (2) of this section, the Department of Consumer and Business Services, or a municipality administering and enforcing a building inspection program, may assess an investigation fee against a person that is required to obtain a permit for work on the electrical, gas, mechanical, elevator, boiler, plumbing or other systems of a building or structure if the work is commenced before the permit required for the work is obtained. The amount of the investigation fee shall be the average or actual additional cost of ensuring that a building, structure or system is in conformance with state building code requirements that results from the person not obtaining a required permit before work for which the permit is required commences.

(2) This section does not apply to: (a) An emergency repair required for health, safety, the prevention of property damage or the prevention of financial harm if the required building permit for the repair is obtained no later than five business days after commencement of the repair; or (b) Any project for which construction, alteration, repair, maintenance or installation in a building or structure prior to obtaining a permit is expressly authorized by law.

(3) The department may adopt rules and establish policies and procedures for use by the department or municipalities in assessing an investigation fee under this section. [2013 c.324 §2]

109.5 Related fees. The payment of the fee for the construction, *alteration*, removal or demolition for work done in connection to or concurrently with the work authorized by a building *permit* shall not relieve the applicant or holder of the *permit* from the payment of other fees that are prescribed by law.

109.6 Refunds. The *building official* is authorized to establish a refund policy.

SECTION 110 INSPECTIONS

110.1 General. Construction or work for which a *permit* is required shall be subject to inspection by the *building official* and such construction or work shall remain visible and able to be accessed for inspection purposes until *approved*. Approval as a result of an inspection shall not be construed to be an approval of a violation of the provisions of this code or of other [laws](#). Inspections presuming to give authority to violate or cancel the provisions of this code or of other [laws](#) shall not be valid. It shall be the duty of the *owner* or the *owner's* authorized agent to cause the work to remain visible and able to be accessed for inspection purposes. Neither the *building official* nor the [municipality](#) shall be liable for expense entailed in the removal or replacement of any material required to allow inspection. [Nothing in this code limits a local municipality's ability to require application of its own ordinances, or to enforce its own ordinances.](#)

110.2 Preliminary inspection. Before issuing a *permit*, the *building official* is authorized to examine or cause to be examined buildings, structures and sites for which an application has been filed.

110.3 Required inspections. The *building official*, upon notification, shall make the inspections set forth in Sections 110.3.1 through 110.3.12. [The building official may adopt local policies approving specific inspection recording methods.](#)

110.3.1 Footing and foundation inspection. Footing and foundation inspections shall be made after excavations for footings are complete and any required reinforcing steel is in place. For concrete foundations, any required forms shall be in place prior to inspection. Materials for the foundation shall be on the job, except where concrete is ready mixed in accordance with ASTM C94, the concrete need not be on the job.

110.3.2 Concrete slab and under-floor inspection. Concrete slab and under-floor inspections shall be made after in-slab or under-floor reinforcing steel and building service equipment, conduit, piping accessories and other ancillary equipment items are in place, but before any concrete is placed or floor sheathing installed, including the subfloor.

110.3.3 Lowest floor elevation. In *flood hazard areas*, upon placement of the lowest floor, including the *basement*, and prior to further vertical construction, the elevation certification required in Section 1612.4 shall be submitted to the *building official* [as required for building code administration and to the flood plain administrator in the management of any NFIP requirements.](#)

110.3.4 Frame inspection. Framing inspections shall be made after the roof deck or sheathing, all framing, *fireblocking* and bracing are in place and pipes, chimneys and vents to be concealed are complete and the rough electrical, plumbing, heating wires, pipes and ducts are *approved*.

110.3.5 Types IV-A, IV-B and IV-C connection protection inspection. In buildings of Types IV-A, IV-B and IV-C construction, where connection *fire-resistance ratings* are provided by wood cover calculated to meet the requirements of Section 2304.10.1, inspection of the wood cover shall be made after the cover is installed, but before any other coverings or finishes are installed.

-110.3.6 Lath, gypsum board and gypsum panel product inspection. Lath, gypsum board and gypsum panel product inspections shall be made after lathing, gypsum board and gypsum panel products, interior and exterior, are in place, but before any plastering is applied or gypsum board and gypsum panel product joints and fasteners are taped and finished.

Exception: Gypsum board and gypsum panel products that are not part of a fire-resistance-rated assembly or a shear assembly.

110.3.7 Weather-exposed balcony and walking surface waterproofing. Where balconies or other elevated walking surfaces have *weather-exposed surfaces*, and the structural framing is protected by an impervious moisture barrier, all elements of the impervious moisture barrier system shall not be concealed until inspected and *approved*.

Exception: Where *special inspections* are provided in accordance with Section 1705.1.1, Item 3.

110.3.8 Fire and smoke-resistant penetrations. Protection of joints and penetrations in *fire-resistance-rated* assemblies, *smoke barriers* and smoke partitions shall not be concealed from view until inspected and *approved*.

110.3.9 Energy efficiency inspections. Inspections shall be made to determine compliance with Chapter 13 and shall include, but not be limited to, inspections for: envelope insulation *R* and *U*-values, fenestration *U*-value, duct system *R*-value, and HVAC and water-heating equipment efficiency.

110.3.10 Other inspections. In addition to the inspections specified in Sections 110.3.1 through 110.3.9, the *building official* is authorized to make or require other inspections of any construction work to ascertain compliance with the provisions of this code and other laws that are enforced by the [municipality](#).

110.3.11 Special inspections. For *special inspections*, see Chapter 17.

110.3.12 Final inspection. The final inspection shall be made after all work required by the building *permit* is completed.

110.3.13 Radon mitigation inspections. Where radon mitigation systems are required by Section 1811 or 1812, or both, inspections shall be provided in accordance with the methods and frequency prescribed in this section.

110.3.13.1 Inspection of subfloor preparation. In conjunction with the “concrete slab and under-floor inspection” required by Section 110.3.2, the *building official* shall conduct subfloor preparation inspections. Such inspections shall be made after the placement of the gas-permeable layer in accordance with the compliance method selected in Section 1811.2.1 or 1812, or both. Depending on the method of construction, inspections shall include, but not be limited to:

1. Aggregate type and placement.
2. Sand type and placement.
3. Geotextile fabric placement.
4. Gas conveyance piping system placement in accordance with Section 1811.3.4.
5. Radon suction pits, including plenum boxes, collection pits, etc.
6. Preparations for installation of subslab soil exhaust ducts.
7. Other inspections as required by the *building official* to ensure compliance with selected alternate methods or engineered systems.

110.3.13.2 Inspection of walls in contact with soil gas. For designs incorporating walls in contact with soil gas, the *building official* shall conduct inspections for compliance with Section 1811.2.4. This inspection shall be made in conjunction with the “footing and foundation inspection” required by Section 110.3.1.

110.3.13.3 Inspection of subslab soil exhaust system duct (SSED). In conjunction with the “frame inspection” required by Section 110.3.4, the *building official* shall conduct SSED inspections. Such inspections shall be made after the placement and identification of all SSEDs as required by Sections 1811.2.5 and 1812.3.7, and where an active soil depressurized system is selected in accordance with Section 1811.3.2.

110.3.13.4 Inspection of SSED blower—active soil depressurization systems (ASD). In conjunction with the “final inspection” required by Section 110.3.12, the *building official* shall conduct ASD SSED blower inspections. Such inspections shall be made after the installation of SSED blowers in accordance with Section 1811.3.3.

110.4 Inspection agencies. The *building official* is authorized to accept reports of *approved* inspection agencies, provided that such agencies satisfy the requirements as to qualifications and reliability.

110.5 Inspection requests. It shall be the duty of the holder of the *building permit* or their duly authorized agent to notify the *building official* when work is ready for inspection. It shall be the duty of the *permit* holder to provide access to and means for inspections of such work that are required by this code.

110.6 Approval required. Work shall not be done beyond the point indicated in each successive inspection without first obtaining the approval of the *building official*. The *building official*, upon notification, shall make the requested inspections and shall either indicate the portion of the construction that is satisfactory as completed, or notify the *permit* holder or the *permit* holder’s agent wherein the same fails to comply with this code. Any portions that do not comply shall be corrected and such portion shall not be covered or concealed until authorized by the *building official*.

SECTION 111 CERTIFICATE OF OCCUPANCY

Under state authority, buildings occupied without a valid certificate of occupancy or permit are under the enforcement authority of the Office of State Fire Marshal.

Local programs should ensure that adequate local ordinances have been adopted allowing for enforcement action where a certificate of occupancy was not issued or where a permit was not requested.

111.1 Change of occupancy. A building or structure shall not be used or occupied in whole or in part, and a *change of occupancy classification* of a building or structure or portion thereof shall not be made, until the *building official* has issued a certificate of occupancy therefor as provided herein. Issuance of a certificate of occupancy shall not be construed as an approval of a violation of the provisions of this code. Certificates presuming to give authority to violate or cancel the provisions of this code or other - laws shall not be valid.

Exception: Certificates of occupancy are not required for work exempt from *permits* in accordance with Section 105.2.

111.2 Certificate issued. After the *building official* inspects the building or structure and does not find violations of the provisions of this code or other laws that are enforced by the *municipality*, the *building official* shall issue a certificate of occupancy that contains the following:

1. The *building permit* number.
2. The address of the structure.
3. The name and address of the *owner* or the owner’s authorized agent.
4. A description of that portion of the structure for which the certificate is issued.
5. A statement that the described portion of the structure has been inspected for compliance with the requirements of this code for the occupancy, division of occupancy and the use for which the proposed occupancy is classified.
6. The name of the *building official*.
7. The edition of the code under which the *permit* was issued.
8. The use and occupancy, in accordance with the provisions of Chapter 3.
9. The type of construction as defined in Chapter 6.
10. The design *occupant load*.

11. Where an *automatic sprinkler system* is provided, whether the sprinkler system is required.
12. Any special stipulations and conditions of the building permit.

111.3 Temporary occupancy. The *building official* is authorized to issue a temporary certificate of occupancy before the completion of the entire work covered by the *permit*, provided that such portion or portions shall be occupied safely. The *building official* shall set a time period during which the temporary certificate of occupancy is valid.

111.4 Revocation. The *building official* is authorized to suspend or revoke a certificate of occupancy or completion issued under the provisions of this code, in writing, wherever the certificate is issued in error, or on the basis of incorrect information supplied, or where it is determined that the building or structure or portion thereof is in violation of the provisions of this code. Nothing in this code limits a local municipality's ability to require application of its own ordinances, or to enforce its own ordinances.

SECTION 112 SERVICE UTILITIES

Not adopted by the State of Oregon, Building Codes Division, as part of this code. Municipalities may have independent local authority regarding service utilities.

SECTION 113 MEANS OF APPEALS

113.1 General. The local municipality shall establish a process to review appeals of determinations made by the building official regarding any provision of the specialty codes the municipality administers and enforces, to include a method to identify the local building official or designee and to notify a permit applicant of the provisions of ORS 455.475, see OAR 918-020-0090(1)(c).

Where there are practical difficulties in establishing a local appeals board, appeals filed under the provisions of ORS 455.475 shall satisfy this requirement.

113.2 Limitations on authority. An application for appeal shall be based on a claim that the true intent of this code or the rules legally adopted thereunder have been incorrectly interpreted, the provisions of this code do not fully apply or an equivalent or better form of construction is proposed. An appeals board, where appointed, shall not have authority to waive requirements of this code or interpret the administration of this code.

113.3 Qualifications. An appeals board, where appointed, shall consist of members who are qualified by experience and training to pass on matters pertaining to building construction.

113.4 Alternative appeal process. ORS 455.475 provides an alternative appeal process to any established by a local municipality. An applicant for a building permit may choose to appeal a building official's decision regarding a particular specialty code to a local appeals board or directly to the appropriate specialty code program chief.

Note: Forms for filing an appeal under ORS 455.475 are available online at: Oregon.gov/bcd.

ORS 455.475 is not part of this code but is reprinted here for the reader's convenience:

455.475. Appeal of decision of building official.

(1) An applicant for a building permit may appeal a decision made by a building official under authority established pursuant to ORS 455.148, 455.150 or 455.467. The following apply to an appeal under this subsection:

(a) An appeal regarding the interpretation or application of a particular specialty code provision shall be made first to the appropriate specialty code chief inspector of the Department of Consumer and Business Services. The decision of the department chief inspector may be appealed to the appropriate advisory board. The decision of the advisory board may only be appealed to the Director of the Department of Consumer and Business Services if codes in addition to the applicable specialty code are at issue.

(b) If the appropriate advisory board determines that a decision by the department chief inspector is a major code interpretation, then the inspector shall distribute the decision in writing to all applicable specialty code public and private inspection authorities in the state. The decision shall be distributed within 60 days after the board's determination, and there shall be no charge for the distribution of the decision. As used in this paragraph, a "major code interpretation" means a code interpretation decision that affects or may affect more than one job site or more than one inspection jurisdiction.

(2) Except as provided in subsection (1) of this section, an applicant for a building permit may appeal the decision of a building official on any matter relating to the administration and enforcement of this chapter to the department. The appeal must be in writing. A decision by the department on an appeal filed under this subsection is subject to judicial review as provided in ORS 183.484.

(3) If an appeal is made under this section, an inspection authority shall extend the plan review deadline by the number of days it takes for a final decision to be issued for the appeal. [1999 c.1045]

SECTION 114 VIOLATIONS

114.1 Prohibited acts. Prohibited acts are as described in ORS 455.450.

ORS 455.450 is not part of this code but is reprinted here for the reader's convenience:

455.450 Prohibited acts. A person may not:

(1) Violate, or procure or assist in the violation of, any final order the Director of the Department of Consumer and Business Services, an advisory board, a state administrative officer or any local appeals board, building official or inspector, concerning the application of the state building code in a particular case or concerning a license, certificate, registration or other authorization.

(2) Engage in, or procure or assist any other person to engage in, any conduct or activity for which a permit, label, license, certificate, registration or other formal authorization is required by any specialty code, any provision of ORS 446.003 to 446.200, 446.225 to 446.285, 446.395 to 446.420, 446.566 to 446.646, 446.666 to 446.746, 479.510 to 479.945, 479.950 and 480.510 to 480.670, this chapter or ORS chapter 447, 460 or 693 or any rule adopted or order issued for the administration and enforcement of these provisions without first having obtained such permit, label, license, certificate, registration or other formal authorization.

(3) Violate, or procure or assist in the violation of, any standard, specification, requirement, prohibition or other technical provision set forth in the state building code or an applicable local building code or in any rule or order of the Department of Consumer and Business Services, an advisory board, a local governing body or local building official. [Formerly 456.885 (1); 2007 c.306 §3]

114.2 Notice of violation. The *building official* is authorized to serve a notice of violation or order on the person responsible for the construction, reconstruction, alteration and repair of a building or structure in violation of the provisions of this code, or in violation of a *permit* or certificate issued under the provisions of this code. Such order shall direct the discontinuance of the illegal action or condition and the abatement of the violation.

114.3 Prosecution of violation. If the notice of violation is not complied with promptly, the *building official* is authorized to request the legal counsel of the municipality to institute the appropriate proceeding at law.

114.4 Violation penalties. Any person who violates a provision of this code or fails to comply with any of the requirements thereof or who erects, constructs, alters or repairs a building or structure in violation of the *approved construction documents* or directive of the *building official*, or of a *permit* or certificate issued under the provisions of this code, shall be subject to penalties as prescribed by law.

114.5 Penalties. Penalty amounts other than those described in Section 109.4 are limited by ORS 455.895. Local authority to levy penalties is limited to violations of code application only.

ORS 455.895 is not part of this code but is reprinted here for the reader's convenience:

455.895 Civil penalties.

(2) The Department of Consumer and Business Services, or an appropriate advisory board, if any, may at its discretion impose a civil penalty against any person who violates the state building code or ORS 446.003 to 446.200, 446.225 to 446.285, 446.395 to 446.420, 446.566 to 446.646, 446.666 to 446.746, 479.510 to 479.945, 479.950 or 480.510 to 480.670, or this chapter or ORS chapter 447, 460 or 693, or any rule adopted or order issued for the administration and enforcement of those statutes. Except as provided in subsections (3), (4) and (9) of this section or ORS 446.995, a civil penalty imposed under this section must be in an amount determined by the appropriate advisory board or the department of not more than \$5,000 for each offense or, in the case of a continuing offense, not more than \$1,000 for each day of the offense.

(3) Each violation of ORS 446.003 to 446.200 or 446.225 to 446.285, or any rule or order issued under ORS 446.003 to 446.200 or 446.225 to 446.285, constitutes a separate violation with respect to each manufactured structure or with respect to each failure or refusal to allow or perform an act required thereby, except that the maximum civil penalty may not exceed \$1 million for any related series of violations occurring within one year from the date of the first violation.

(4) The department may impose a civil penalty of not more than \$25,000 against a public body responsible for administering and enforcing a building inspection program. As used in this subsection, "public body" has the meaning given that term in ORS 174.109.

(5) The maximum penalty established by this section for a violation may be imposed only upon a finding that the person has engaged in a pattern of violations. The department, by rule, shall define what constitutes a pattern of violations. Except as provided in subsections (1) and (10) of this section, moneys received from any civil penalty under this section are appropriated continuously for and shall be used by the department for enforcement and administration of provisions and rules described in subsection (2) of this section.

(6) Civil penalties under this section shall be imposed as provided in ORS 183.745.

(7) A civil penalty imposed under this section may be remitted or reduced upon such terms and conditions as the department or the appropriate advisory board considers proper and consistent with the public health and safety. In any judicial review of a civil penalty imposed under this section, the court may, in its discretion, reduce the penalty.

(8) Any officer, director, shareholder or agent of a corporation, or member or agent of a partnership or association, who personally participates in or is an accessory to any violation by the partnership, association or corporation of a provision or rule described in subsection (2) of this section is subject to the penalties prescribed in this section.

(9) an addition to the civil penalty set forth in subsection (1) or (2) of this section, any person who violates a provision or rule described in subsection (2) of this section may be required by the department or the appropriate advisory board to forfeit and pay to the General Fund of the State Treasury a civil penalty in an amount determined by the department or advisory board that does not exceed five times the amount by which such person profited in any transaction that violates a provision or rule described in subsection (2) of this section.

(10) If a civil penalty is imposed for a violation of a provision of ORS 446.566 to 446.646 and the violation relates to a filing or failure to file with a county assessor functioning as agent of the department, the department, after deducting an amount equal to the department's procedural, collection and other related costs and expenses, shall forward one-half of the remaining civil penalty amount to the county in which the manufactured structure is located at the time of the violation. [1991 c.792 §4; 1991 c.734 §111; 1999 c.1045 §19; 2001 c.411 §21; 2003 c.14 §286; 2003 c.655 §76; 2007 c.549 §6; 2007 c.898 §1; 2013 c.324 §11]

SECTION 115 STOP WORK ORDER

Not adopted by the State of Oregon, Building Codes Division, as part of this code. A *municipality* may have authority outside of this code to regulate these matters locally, where not preempted.

SECTION 116 UNSAFE STRUCTURES AND EQUIPMENT

Not adopted by the State of Oregon Building Codes Division as part of this code. A *municipality* may have authority outside of this code to regulate these matters locally, where not preempted.

CHAPTER 2 DEFINITIONS

Section 201 General

IBC 201.4 **201.4 Terms not defined.** Where terms are not defined through the methods authorized by this section, such terms shall have ordinarily accepted meanings such as the context implies. Words of common usage are given their plain, natural and ordinary meanings. Words that have well-defined legal meanings are given those meanings.

Section 202 Definitions

A

ACCESSIBLE SPACE. A space that complies with Chapter 11.

ADHERED MASONRY VENEER. *Veneer* secured and supported through the adhesion of an *approved* bonding material applied to an *approved* backing. Type and spacing of fasteners shall be noted on construction documents.

ADJACENT ROOF PLANE. See “Solar roof plane.”

ADULT FOSTER HOME. See ORS 443.705(1).

AEROSOL COOKING SPRAY PRODUCTS. Aerosol cooking spray products are those aerosol products designed to deliver a vegetable oil or a solid or nonflammable liquid to reduce sticking on cooking and baking surfaces, or to be applied to food, or both. These products have a chemical heat of combustion that is greater than 8,600 Btu/lb (20 kJ/g) and contain not more than 18 percent by weight of flammable propellant.

AEROSOL PRODUCT WAREHOUSE. A building used for warehousing aerosol products.

AFFECTED BUILDINGS. See ORS 447.210(1)

ORS 447.210(1) is not a part of this code but is reprinted here for the reader’s convenience:

447.210 Definitions. (1) “Affected buildings” includes any place of public accommodations and commercial facilities designed, constructed and altered in compliance with the accessibility standards established by the Americans with Disabilities Act. “Affected buildings” also includes any government building that is subject to Title II of the Americans with Disabilities Act. “Affected buildings” also includes private entities, private membership clubs and churches that have more than one floor level and more than 4,000 square feet in ground area or that are more than 20 feet in height, measured from the top surface of the lowest flooring to the highest interior overhead finish of the building.

AGRICULTURAL BUILDING. See ORS 455.315 and Appendix C. ~~A structure designed and constructed to house farm implements, hay, grain, poultry, livestock or other horticultural products. This structure shall not be a place of human habitation or a place of employment where agricultural products are processed, treated or packaged, nor shall it be a place used by the public.~~

AGRO-INDUSTRIAL. A facility, or portion thereof, housing operations involving the transforming of raw agricultural products into intermediate or consumable products.

AIR-IMPERMEABLE INSULATION. *(Not adopted)*

ALARM, NUISANCE. See “Nuisance alarm.”

A
(continued)

ALARM DEVICE, MULTIPLE STATION. See “*Multiple-station alarm device.*”

AMERICANS WITH DISABILITIES ACT. See ORS 447.210(2).

ANCHOR. Metal rod, wire or strap that secures *masonry* to its structural support.

APPROVED FIELD EVALUATION FIRM. An organization primarily established for purposes of testing to approved standards and approved by the local *municipality*.

ARCHITECTURAL BARRIER. See ORS 447.210(3).

AREA, ROOF. See “*Solar roof plane.*”

AREA OF SPORT ACTIVITY. That portion of an indoor or outdoor space on the site of an affected building where the play or practice of a sport occurs.

ARRAY, PHOTOVOLTAIC. See “*Photovoltaic array.*”

ARRAY, CLOSED. A storage configuration having a 6-inch (152 mm) or smaller width vertical flue space that restricts air movement through the stored commodity.

ARRAY, STORAGE. The configuration of storage. Characteristics considered in defining an array include the type of packaging, flue spaces, height of storage and compactness of storage.

AUTOMATED RACK STORAGE. A stocking method whereby the movement of pallets, products, apparatus or systems are automatically controlled by mechanical or electronic devices.

B

BALCONY, EXTERIOR. An exterior floor system projecting from and supported completely by an adjoining structure without any additional supports provided to the floor system.

BATTERY SYSTEM, STATIONARY STORAGE. A rechargeable energy storage system consisting of electrochemical storage batteries, battery chargers, controls and associated electrical equipment designed to provide electrical power to a building. The system is typically used to provide standby or emergency power, an uninterruptable power supply, load shedding, load sharing or similar capabilities.

BATTERY TYPES.

Flow battery. A type of storage battery that includes chemical components dissolved in two different liquids. Ion exchange, which provides the flow of electrical current, occurs through the membrane while both liquids circulate in their respective spaces.

Lead-acid battery. A storage battery that is comprised of lead electrodes immersed in sulphuric acid electrolyte.

Lithium-ion battery. A storage battery with lithium ions serving as the charge carriers of the battery. The electrolyte is a polymer mixture of carbonates with an inorganic salt and can be in a liquid or a gelled polymer form. Lithiated metal oxide is typically a cathode and forms of carbon or graphite typically form the anode.

Nickel-cadmium (Ni-Cd) battery. An alkaline storage battery in which the positive active material is nickel oxide, the negative contains cadmium and the electrolyte is potassium hydroxide.

Preengineered stationary storage battery system. An energy storage system consisting of batteries, a battery management system, components and modules that are produced in a factory and designed to comprise the system when assembled on the job site.

Prepackaged stationary storage battery system. An energy storage system consisting of batteries, a battery management system, components and modules that is factory assembled and shipped as a complete unit for installation at the job site.

B
(continued)

Sodium-beta storage battery. A storage battery, also referred to as a Na-beta battery or NBB, which uses a solid beta-alumina electrolyte membrane that selectively allows sodium ion transport between a positive electrode such as metal halide and a negative sodium electrode.

Stationary storage battery. A group of electrochemical cells interconnected to supply a nominal voltage of DC power to a suitably connected electrical load, designed for service in a permanent location.

BIN BOX. A five-sided container with the open side facing an aisle. *Bin boxes* are self-supporting or supported by a structure designed so that little or no horizontal or vertical space exists around the boxes.

BOILER CODE. For the purposes of this code, *Boiler Code* shall mean the *Oregon Boiler and Pressure Vessel Specialty Code* as adopted by OAR 918-225-0430. The *Boiler Code* is expressly enforced by the Oregon Building Codes Division. Inspections and plan review are performed only by inspectors authorized by the state.

BUILDING CODE. For the purposes of this code, *Building Code* shall mean the *Oregon Structural Specialty Code* as adopted by OAR 918-460-0010.

BUILDING OFFICIAL. The officer or other designated authority charged with the administration and enforcement of this code, or a duly authorized representative.

455.715 Definitions for ORS 455.715 to 455.740.

As used in ORS 455.715 to 455.740, unless the context otherwise requires:

(1) "Building official" means a person charged by a municipality with responsibility for administration and enforcement of the state building code in the municipality.

BULK OXYGEN SYSTEM. An assembly of equipment, such as oxygen storage containers, pressure regulators, safety devices, vaporizers, manifolds and interconnecting piping, that has a storage capacity of more than 20,000 cubic feet (566 m³) of oxygen at *normal temperature and pressure (NTP)*, including unconnected reserves on hand at the site. The *bulk oxygen system* terminates at the point where oxygen at service pressure first enters the supply line. The oxygen containers can be stationary or movable, and the oxygen can be stored as a gas or liquid.

BULK TRANSFER. The loading or unloading of flammable or *combustible liquids* from or between tank vehicles, tank cars or storage tanks.

BUTT JOINT. A nonbonded plain, square joint, a keyed joint or a doweled joint between two members, where primary movement is at right angles to the plane of the joint. Sealant in a *butt joint* will generally be in tension or compression, but not shear.

C

CAPACITOR ARRAY. An arrangement of individual capacitor modules in close proximity to each other, mounted on storage racks or in cabinets or other enclosures.

CARBON DIOXIDE ENRICHMENT SYSTEM. A system where carbon dioxide gas is intentionally introduced into an indoor environment, typically for the purpose of stimulating plant growth.

CARTON. A cardboard or fiberboard box enclosing a product.

CELL (Group I-3 occupancy). (Not adopted)

CELL. A housing unit in a detention or correctional facility for the confinement of not more than two residents.

CELL DORMITORY. A housing area in a detention or correctional facility designated to house three or more residents.

C
(continued)

CELL COMPLEX. A cluster or group of cells in a jail, prison or other detention facility, together with rooms used for accessory purposes, all of which open into the cell complex, and are used for functions such as dining, counseling, exercise, classrooms, sick call, visiting, storage, staff offices, control rooms or similar functions, and interconnecting corridors all within the cell complex.

CELL TIER. (Not adopted)

CELL TIERS. Cells, dormitories and accessory spaces. Cell tiers are located one level above the other, and do not exceed two levels per floor. A cell tier shall not be considered a story or mezzanine.

CHEMICAL. An element, chemical compound, or mixture of elements or compounds or both.

CHANGE OF OCCUPANCY. ~~Either~~ Any of the following shall be considered as a change of occupancy where this code requires a greater degree of safety, accessibility, structural strength, fire protection, means of egress, ventilation or sanitation than is existing in the current building or structure:

1. Any change in the occupancy classification of a building or structure.
2. Any change in the purpose of, or a change in the level of activity within, a building or structure.
3. A change of use.

CHANGE OF USE. A change in the use of a building or a portion of a building, within the same group classification, for which there is a change in application of the code requirements.

CIRCULATION PATH. An exterior or interior way of passage from one place to another for pedestrians.

CLEAN AGENT. Electrically nonconducting, volatile or gaseous fire extinguishant that does not leave a residue upon vaporation.

CLIMATE ZONE. A geographical region that has been assigned climatic criteria as specified in ~~Chapters 3 [CE] and 3 [RE]~~ of the *International Energy Conservation Code*.

CLOSED CONTAINER. A container sealed by means of a lid or other device such that liquids, vapors or dusts will not escape from it under ordinary conditions of use or handling.

CLUSTERED MAILBOXES. Clustered mailbox units, which are also known as Centralized Box Units or CBUs, are freestanding mailbox units with multiple locked mailboxes, along with parcel lockers and a slot for mail collection.

COLUMBARIUM. A permanent structure consisting of niches.

COMMERCIAL COOKING APPLIANCES. Appliances used in a commercial food service establishment for heating or cooking food. For the purpose of this definition, a commercial food service establishment is where food is prepared for sale or is prepared on a scale that is by volume and frequency not representative of domestic household cooking.

COMMODITY. A combination of products, packing materials and containers.

COMPANION CRYPT. A permanent chamber for containment of human remains of not more than four individuals.

COMPRESSED GAS CONTAINER. A pressure vessel designed to hold compressed gases at pressures greater than one atmosphere at 68°F. (20°C), including cylinders, containers and tanks.

COMPRESSED GAS SYSTEM. An assembly of equipment designed to contain, distribute or transport compressed gases. It can consist of a compressed gas container or containers, reactors and appurtenances, including pumps, compressors and connecting piping and tubing.

C
(continued)

CONSTRUCTION. As it relates to the *state building code*, is the systematic process, act or manner of constructing or assembling a building in part or in whole and any system, device or equipment regulated by the *state building code*.

CONSTRUCTION JOINT. The surface where two successive placements of concrete meet and are to be bonded; reinforcement is not interrupted, and tie bars are used as required.

CONTAINER. A vessel of 60 gallons (227 L) or less in capacity used for transporting or storing *hazardous materials*. Pipes, piping systems, engines and engine fuel tanks are not considered to be containers.

CONTAINMENT SYSTEM. A gastight recovery system comprised of equipment or devices that can be placed over a leak in a *compressed gas container*, thereby stopping or controlling the escape of gas from the leaking container.

CONTAINMENT VESSEL. A gastight recovery vessel designed so that a leaking *compressed gas container* can be placed within its confines, thereby encapsulating the leaking container.

CONTRACTION JOINT. A formed or sawed groove in a concrete structure, extending normal to the surface and to a depth of at least one-fourth the thickness of a concrete element, for the purpose of creating a weakened plane that induces a crack as internal stresses develop due to drying shrinkage.

COTTON.

Baled cotton. A natural seed fiber wrapped in and secured with industry-accepted materials, usually consisting of burlap, woven polypropylene, polyethylene or cotton or sheet polyethylene, and secured with steel, synthetic or wire bands, or wire; also includes linters (lint removed from the cottonseed) and motes (residual materials from the ginning process).

Baled cotton, densely packed. Cotton, made into banded bales, with a packing density of not less than 22 pounds per cubic foot (352 kg/m³), and dimensions complying with the following: a length of 55 inches (1397 mm), a width of 21 inches (533.4 mm) and a height of 27.6 to 35.4 inches (701 to 899 mm).

Seed cotton. Perishable raw agricultural commodity consisting of cotton fiber (lint) attached to the seed of the cotton plant, which requires ginning to become a commercial product.

COVERED MULTIFAMILY DWELLINGS. See ORS 447.210(5). As part of this code, “Covered multifamily dwellings” are applicable only to *covered multifamily dwellings* designed and constructed for first occupancy after March 13, 1991, or where the last building permit or renewal thereof was issued on or before June 15, 1990. For the purposes of application, “first occupancy” means “a building that has never before been used for any purpose.”

ORS 447.210(5) is not a part of this code but is reprinted here for the reader’s convenience:
447.210 Definitions.
(5) “Covered multifamily dwellings” means buildings consisting of four or more dwelling units if such buildings have one or more elevators, and ground floor dwelling units in other buildings consisting of four or more dwelling units. Dwelling units within a single structure separated by firewalls do not constitute separate buildings.

CRYOGENIC CONTAINER. A cryogenic vessel of any size used for the transportation, handling or storage of *cryogenic fluids*.

CRYOGENIC VESSEL. A pressure vessel, low-pressure tank or atmospheric tank designed to contain a *cryogenic fluid* on which venting, insulation, refrigeration or a combination of these is used in order to maintain the operating pressure within the design pressure and the contents in a liquid phase.

C
(continued)

CRYPT. A permanent chamber for containment of human remains.

CURING. For concrete, the maintenance of a satisfactory moisture content and temperature during its early stages so that desired properties may develop. For sealants, the maintenance of a satisfactory moisture content and temperature while the physical properties of the sealant are changed by chemical reaction.

CURING COMPOUND. A liquid that can be applied as a coating to the surface of newly placed concrete to retard the loss of water, or in the case of pigmented compounds, also to reflect heat so as to provide an opportunity for the concrete to develop its properties in a favorable temperature and moisture environment.

CUTOUT. An area adjacent to a pathway for use by firefighters to cut a vent if needed. Cutouts shall not be less than 30 inches (762 mm) in any dimension.

CYLINDER. A pressure vessel designed for pressures higher than 40 psia (275.8 kPa) and having a circular cross section. It does not include a portable tank, multiunit tank car tank, cargo tank or tank car.

D

DAYROOM. A room that is adjacent to a cell, cell tier or dormitory and that is used as a dining, exercise or other activity room for residents.

DECK, ATTACHED. An exterior floor system supported on at least one side by the exterior wall of the adjoining structure and supported on the opposing side by posts, piers or other support methods.

DECK, DETACHED. An exterior floor system not anchored to a structure and is provided with its own independent support system.

DESIGN FLOOD. The flood associated with an area designated as a flood hazard area by the flood plain administrator, the greater of the following two areas:

1. Area with a flood plain subject to a 1 percent or greater chance of flooding in any year.
2. Area designated as a flood hazard area on a community's flood hazard map, or otherwise legally designated.

DESIGN FLOOD ELEVATION. The elevation of the "design flood," including wave height, relative to the datum specified on the community's legally designated flood hazard map. ~~In~~ areas designated as Zone AO, the design flood elevation shall be the elevation of the highest existing grade of the building's perimeter plus the depth number (in feet) specified on the flood hazard map. In areas designated as Zone AO where a depth number is not specified on the map, the depth number shall be taken as being equal to 2 feet (610 mm).

DESIGN PRESSURE. The maximum gauge pressure that a pressure vessel, device, component or system is designed to withstand safely under the temperature and conditions of use expected.

DESOLVENTIZING. The act of removing a solvent from a material.

DETEARING. A process for rapidly removing excess wet coating material from a dipped or coated object or material by passing it through an electrostatic field.

DETERIORATION. The physical manifestation of failure of a material or assembly (e.g., cracking, delamination, flaking, pitting, scaling) caused by environmental or internal autogenous influences during testing or service.

DETONATING CORD. A flexible cord containing a center core of high explosive used to initiate other explosives.

DIP TANK. A tank, vat or container of flammable or combustible liquid in which articles or materials are immersed for the purpose of coating, finishing, treating and similar processes.

D
(continued)

DRAFT CURTAIN. A structure arranged to limit the spread of smoke and heat along the underside of the ceiling or roof.

DRAIN TILE LOOP. A continuous length of drain tile or perforated pipe extending around all or part of the internal or external perimeter of a basement or crawl space footing.

DRY CLEANING. The process of removing dirt, grease, paints and other stains from such items as wearing apparel, textiles, fabrics and rugs by use of nonaqueous liquids (solvents).

DRY CLEANING PLANT. A facility in which dry cleaning and associated operations are conducted, including the office, receiving area and storage rooms.

DRY CLEANING ROOM. An occupiable space within a building used for performing dry cleaning operations, operating solvent-handling equipment or storing of dry cleaning solvents.

DRY CLEANING SYSTEM. Machinery or equipment in which textiles are immersed or agitated in solvent or in which dry cleaning solvent is extracted from textiles.

DURATION OF LOAD. The period of continuous application of a given *load*, or the aggregate of periods of intermittent applications of the same *load*.

E

EARLY SUPPRESSION FAST-RESPONSE (ESFR) SPRINKLER. A sprinkler *listed* for early suppression fast-response performance.

ELASTOMERIC SEALANT. A sealant whose macromolecular material returns rapidly to approximately its initial dimensions and shape after substantial deformation by a weak stress and release of the stress.

ELECTRICAL CODE. For the purposes of this code, *Electrical Code* shall mean the *Oregon Electrical Specialty Code* as adopted by OAR 918-305-0100.

ELECTROSTATIC FLUIDIZED BED. A container holding powder coating material that is aerated from below so as to form an air-supported expanded cloud of such material that is electrically charged with a charge opposite to that of the object to be coated. Such object is transported through the container immediately above the charged and aerated materials in order to be coated.

ELEMENT. An architectural or mechanical component of a building, facility, space or site, such as a telephone, curb ramp, door, drinking fountain, seating, clustered mailboxes or water closet.

ELEVATOR CODE. For the purposes of this code, *Elevator Code* shall mean the *Oregon Elevator Specialty Code* as adopted by OAR 918-400-0455. The *Elevator Code* is expressly enforced by the Oregon Building Codes Division. Inspections and plan review are performed only by inspectors authorized by the state.

EMERGENCY SHUTOFF VALVE. A valve designed to shut off the flow of gases or liquids.

EMERGENCY SHUTOFF VALVE, AUTOMATIC. A fail-safe automatic-closing valve designed to shut off the flow of gases or liquids initiated by a control system that is activated by automatic means.

EMERGENCY SHUTOFF VALVE, MANUAL. A manually operated valve designed to shut off the flow of gases or liquids.

ENERGY CODE. For the purposes of this code, *Energy Code* shall mean the energy provisions adopted by OAR 918-460-0500.

E
(continued)

EQUIPMENT OR FIXTURE. Any facilities or installations that are related to building services and for which the *state building code* provides specific requirements. “Equipment” or “Fixture” shall not include manufacturing, production, process equipment or other equipment not regulated by the *state building code*.

ESSENTIAL FACILITIES. *Risk Category IV* buildings and other structures ~~that are intended to remain operational in the event of extreme environmental loading from flood, wind, snow or earthquakes~~ determined in accordance with Section 1604.5.

EXCESS FLOW CONTROL. A fail-safe system or other *approved* means designed to shut off flow caused by a rupture in pressurized piping systems.

EXPLOSIVE MATERIAL. The term “explosive” material means *explosives*, blasting agents and detonators.

EXTRA-HIGH-RACK COMBUSTIBLE STORAGE. Storage of Class I, II, III or IV commodities on racks that exceed 40 feet (12 192 mm) in height and storage of high-hazard commodities on racks that exceed 30 feet (9144 mm) in height.

F

FIELD-MOLDED SEALANT. A liquid or semisolid material molded into the desired shape in the joint into which it is installed.

FINES. Small pieces or splinters of wood byproducts that will pass through a 0.25-inch (6.4 mm) screen.

FLAMMABLE CRYOGENIC FLUID. A *cryogenic fluid* that is flammable in its vapor state.

FLAMMABLE FINISHES. Coatings to articles or materials in which the material being applied is a flammable liquid, combustible liquid, combustible powder, fiberglass resin or flammable or combustible gel coating.

FLAMMABLE VAPOR AREA. An area in which the concentration of flammable constituents (vapor, gas, fume, mist or dust) in the air exceeds 25 percent of their *lower flammable limit* (LFL) because of the flammable finish processes operation. It shall include:

1. The interior of spray booths.
2. The interior of ducts exhausting from spraying processes.
3. Any area in the direct path of spray or any area containing dangerous quantities of air-suspended powder, combustible residue, dust, deposits, vapor or mists as a result of spraying operations.
4. The area in the vicinity of dip tanks, drain boards or associated drying, conveying or other equipment during operation or shutdown periods.

~~The building official is authorized to determine the extent of the flammable vapor area, taking into consideration the material characteristics of the flammable materials, the degree of sustained ventilation and the nature of the operations.~~

FLOAT. A floating structure normally used as a point of transfer for passengers and goods, or both, for mooring purposes.

FLOOD HAZARD AREA. The area designated as a flood hazard area by the *flood plain administrator*. ~~The greater of the following two areas:~~

1. ~~The area within a flood plain subject to a 1 percent or greater chance of flooding in any year.~~
2. ~~The area designated as a flood hazard area on a community’s flood hazard map, or otherwise legally designated.~~

FLOOD PLAIN ADMINISTRATOR. See Section 102.4.3.

F
(continued)

FLUE SPACES.

Longitudinal flue space. The flue space between rows of storage perpendicular to the direction of loading.

Transverse flue space. The space between rows of storage parallel to the direction of loading.

FLUIDIZED BED. A container holding powder coating material that is aerated from below so as to form an air-supported expanded cloud of such material through which the preheated object to be coated is immersed and transported.

FUEL GAS CODE. For the purpose of this code, *Fuel Gas Code* shall mean Appendix C of the *Oregon Mechanical Specialty Code (OMSC)* as adopted by OAR 918-440-0010.

FURNACE CLASS A. An oven or furnace that has heat utilization equipment operating at approximately atmospheric pressure wherein there is a potential explosion or fire hazard that could be occasioned by the presence of flammable volatiles or combustible materials processed or heated in the furnace.

Note: Such flammable volatiles or combustible materials can, for instance, originate from the following:

1. Paints, powders, inks, and adhesives from finishing processes, such as dipped, coated, sprayed and impregnated materials.
2. The substrate material.
3. Wood, paper and plastic pallets, spacers or packaging materials.
4. Polymerization or other molecular rearrangements. Potentially flammable materials, such as quench oil, waterborne finishes, cooling oil or Class C classification are integral quench furnaces and molten salt bath furnaces.

FURNACE CLASS B. An oven or furnace that has heat utilization equipment operating at approximately atmospheric pressure wherein there are no flammable volatiles or combustible materials being heated.

G

GLOVE BOX. A sealed enclosure in which items inside the box are handled exclusively using long gloves sealed to ports in the enclosure.

H

HIGHLY VOLATILE LIQUID. A liquefied *compressed gas* with a *boiling point* of less than 68°F (20°C).

HIGH-PILED COMBUSTIBLE STORAGE. Storage of combustible materials in closely packed piles or combustible materials on pallets, in racks or on shelves where the top of storage is greater than 12 feet (3658 mm) in height. Where required by the *building official*, *high-piled combustible storage* also includes certain high-hazard commodities, such as rubber tires, Group A plastics, flammable liquids, idle pallets and similar commodities, where the top of storage is greater than 6 feet (1829 mm) in height.

HIGH-PILED STORAGE AREA. An area within a building that is designated, intended, proposed or actually used for *high-piled combustible storage*, including operating aisles.

HIGH-RANGE WATER REDUCER. A chemical admixture capable of reducing the water content of concrete at least 12 percent. This admixture shall conform to ASTM C494, Type F and/or Type O.

HIGH-RISE BUILDING. A building with an occupied floor located more than 75 feet (22 860 mm) above the lowest level of required fire department vehicle access.

H
(continued)

HISTORIC BUILDINGS. Any building or structure that is, in whole or in part, listed or certified as eligible for listing by the National Register of Historic Places, established and maintained under the National Historic Preservation Act of 1966 (P.L. 89-665), or if the National Register of Historic Places ceases accepting nominations, is approved for listing on an Oregon register of historic places, or is a locally designated landmark protected by ordinance.

~~Any building or structure that is one or more of the following:~~

- ~~1. Listed or certified as eligible for listing by the State Historic Preservation Officer or the Keeper of the National Register of Historic Places, in the National Register of Historic Places.~~
- ~~2. Designated as historic under an applicable state or local law.~~
- ~~3. Certified as a contributing resource within a National Register, state designated or locally designated historic district.~~

~~**HOGGED MATERIALS.** Wood waste materials produced from the lumber production process.~~

HONEYCOMB. Voids left in concrete due to failure of the mortar to effectively fill the spaces among coarse aggregate particles.

HOUSING UNIT. A dormitory or a group of cells with a common dayroom in Group I-3. An area intended to lodge residents on a 24-hour basis where accommodations are provided for sleeping.

~~**HPM FACILITY.** See "Semiconductor fabrication facility."~~

HURRICANE-PRONE REGIONS. (Not adopted)

I

~~**INHABITED BUILDING.** A building regularly occupied in whole or in part as a habitation for people, or any place of religious worship, schoolhouse, railroad station, store or other structure where people are accustomed to assemble, except any building or structure occupied in connection with the manufacture, transportation, storage or use of explosive materials.~~

~~**INTEGRATED TESTING (fire protection and life safety system).** A testing procedure to establish the operational status, interaction and coordination of two or more fire protection and safety systems.~~

~~**IRRITANT.** A chemical which is not corrosive, but which causes a reversible inflammatory effect on living tissue by chemical action at the site of contact. A chemical is a skin irritant if, when tested on the intact skin of albino rabbits by the methods of CPSC 16 CFR Part 1500.41 for an exposure of four or more hours or by other appropriate techniques, it results in an empirical score of five or more. A chemical is classified as an eye irritant if so determined under the procedure listed in CPSC 16 CFR Part 1500.42 or other approved techniques.~~

ISOLATION JOINT. A nonbonded separation between adjoining parts of a structure, usually in a vertical plane, designed to allow relative movement in three directions in order to accommodate differential horizontal or vertical movement without the development of cracks elsewhere in the structure. May be either a butt joint or a lap joint, used to structurally separate the floor slab from other building elements.

J

JURISDICTION. See *municipality*. ~~The governmental unit that has adopted this code.~~

L

LAITANCE. A layer of weak and nondurable material containing cement and fines from aggregates, brought by bleeding water to the outer surface of concrete.

L
(continued)

LAP. The length by which one material overlays another at a lap joint.

LAP JOINT. A nonbonded joint in which the materials being joined override each other so that any movement of the materials is primarily parallel to the plane of the joint, putting sealants in shear rather than tension or compression. Formed slab joints that are not attached with a keyway are considered to be lap joints.

LIMITED SPRAYING SPACE. An area in which operations for touch-up or spot painting of a surface area of 9 square feet (0.84 m²) or less are conducted.

LIQUID STORAGE WAREHOUSE. A building classified as a Group H-2 or H-3 occupancy used for the storage of flammable or combustible liquids in a closed condition.

LOCKUP FACILITY. See Section 304.2 and the definition of “lockup” in ORS 169.005(5).

LONGITUDINAL FLUE SPACE. See “Flue space—longitudinal.”

LOWER EXPLOSIVE LIMIT (LEL). See “Lower flammable limit.”

LOW-PRESSURE TANK. A storage tank designed to withstand an internal pressure greater than 0.5 pound per square inch gauge (psig) (3.4 kPa) but not greater than 15 psig (103.4 kPa).

LP-GAS CONTAINER. Any vessel, including cylinders, tanks, portable tanks and cargo tanks, used for transporting or storing LP-gases.

M

MAGAZINE. A building, structure or container, other than an operating building, approved for storage of explosive materials.

Indoor. A portable structure, such as a box, bin or other container, constructed as required for Type 2, 4 or 5 magazines in accordance with NFPA 495, NFPA 1124 or DOTy 27 CFR Part 55 so as to be fire resistant and theft resistant.

Type 1. A permanent structure, such as a building or igloo, that is bullet resistant, fire resistant, theft resistant, weather resistant and ventilated in accordance with the requirements of NFPA 495, NFPA 1124 or DOTy 27 CFR Part 55.

Type 2. A portable or mobile structure, such as a box, skid-magazine, trailer or semitrailer, constructed in accordance with the requirements of NFPA 495, NFPA 1124 or DOTy 27 CFR Part 55, that is fire resistant, theft resistant, weather resistant and ventilated. If used outdoors, a Type 2 magazine is also bullet resistant.

Type 3. A fire-resistant, theft-resistant and weather-resistant “day box” or portable structure constructed in accordance with NFPA 495, NFPA 1124 or DOTy 27 CFR Part 55 used for the temporary storage of explosive materials.

Type 4. A permanent, portable or mobile structure such as a building, igloo, box, semitrailer or other mobile container that is fire resistant, theft resistant and weather resistant and constructed in accordance with NFPA 495, NFPA 1124 or DOTy 27 CFR Part 55.

Type 5. A permanent, portable or mobile structure such as a building, igloo, box, bin, tank, semitrailer, bulk trailer, tank trailer, bulk truck, tank truck or other mobile container that is theft resistant and is constructed in accordance with NFPA 495, NFPA 1124 or DOTy 27 CFR Part 55.

MAGNESIUM. The pure metal and alloys, of which the major part is magnesium.

MAINTENANCE. As it relates to the applicable structural fire safety features and means of egress systems covered in the fire code(s) and the state building code, maintenance is the act of confirming that such systems in occupied structures are maintained in accordance with the plans, drawings and specifications reviewed and approved by the Director of the Department of Consumer and Business Services or a local building official administering a building inspection program under ORS 455.158 or 455.150. Maintenance does not include the act(s) of construction, reconstruction, alteration or repair in new or existing buildings.

M
(continued)

MAJOR STRUCTURE. See ORS 455.447.

MANUAL STOCKING METHODS. Stocking methods utilizing ladders or other nonmechanical equipment to move stock.

MANUFACTURED SANDS. Sands resulting from the crushing of rock, gravel or slag.

MASTIC. A sealant with putty-like properties.

MAUSOLEUM. A permanent structure consisting of crypts.

MAXIMUM ALLOWABLE QUANTITY PER CONTROL AREA. The maximum amount of a hazardous material allowed to be stored or used within a control area inside a building. The maximum allowable quantity per control area is based on the material state (solid, liquid or gas) and the material storage or use conditions.

MECHANICAL CODE. For the purposes of this code, *Mechanical Code* shall mean the *Oregon Mechanical Specialty Code* as adopted by OAR 918-440-0010.

MECHANICAL STOCKING METHODS. Stocking methods utilizing motorized vehicles or hydraulic jacks to move stock.

MEMBRANE. A flexible, continuous sheet. See also: "Membrane-forming curing compound," "Soil-gas-retarder membrane" and "Waterproofing membrane."

MEMBRANE STRUCTURE. An air-inflated, air-supported, cable or frame-covered structure (see Chapter 31).

MEMBRANE-FORMING CURING COMPOUND. A liquid material that, when applied over the surface of freshly placed concrete, forms a solid, impervious layer that holds the mixing water in the concrete.

METAL HYDRIDE. A generic name for compounds composed of metallic element(s) and hydrogen.

METAL HYDRIDE STORAGE SYSTEM. A closed system consisting of a group of components assembled as a package to contain metal-hydrogen compounds for which there exists an equilibrium condition where the hydrogen-absorbing metal alloy(s), hydrogen gas and the metal-hydrogen compound(s) coexist and where only hydrogen gas is released from the system in normal use.

MID-RANGE WATER REDUCER. A chemical admixture capable of reducing the water content of concrete from 6 to 15 percent. This admixture shall conform to ASTM C494, Type A and/or Type F.

MISCELLA. A mixture, in any proportion, of the extracted oil or fat and the extracting solvent.

MODULE. A complete, environmentally protected unit consisting of solar cells, optics and other components, exclusive of tracker, designed to generate power when exposed to sunlight.

MUNICIPALITY. Shall be as defined in ORS 455.010.

ORS 455.010 is not part of this code but is reprinted here for the reader's convenience.

455.010 Definitions for ORS chapter 455. As used in this chapter, unless the context requires otherwise:

(5) "Municipality" means a city, county or other unit of local government otherwise authorized by law to administer a building code.

[Formerly 456.750; 1991 c.227 §1; 1991 c.310 §1; 1993 c.18 §112; 1993 c.744 §85; 1997 c.259 §3; 1999 c.484 §1; 1999 c.1045 §12; 2003 c.655 §75; 2003 c.675 §§10,11; 2009 c.567 §§4,13]

- N**
- NATURAL SANDS.** Sands resulting from the natural disintegration and abrasion of rock.
- NICHE.** A permanent chamber for the containment of cremated human remains of one or more individuals.
- NONOCCUPIED ACCESSORY STRUCTURE.** A structure normally not occupied, such as a garage, carport, shed or agricultural building.
- NONCOMBUSTIBLE MATERIAL.** A material that, under the conditions anticipated, will not ignite or burn when subjected to fire or heat. Materials that pass ASTM E136 are considered *noncombustible materials*.
- O**
- ORGANIC COATING.** A liquid mixture of binders, such as alkyd, nitrocellulose, acrylic or oil, and flammable and combustible solvents, such as hydrocarbon, ester, ketone or alcohol, which when spread in a thin film, convert to a durable protective and decorative finish.
- OVERHEAD FINISH OF A BUILDING.** The lowest point of the interior finished ceiling surface on the uppermost floor level required to be accessible, but in no case shall this point be lower than the highest point used to measure the clear height for an accessible route on that level.
- OXIDIZING CRYOGENIC FLUID.** An oxidizing gas in the cryogenic state.
- OZONE-GAS GENERATOR.** Equipment that causes the production of ozone.
- P**
- PASS-THROUGH.** An enclosure installed in a wall with a door on each side that allows chemicals, HPM, equipment and parts to be transferred from one side of the wall to the other.
- PATHWAY.** Unobstructed route provided within or around the *photovoltaic array* to provide unimpeded access and egress for firefighting purposes.
- PERMISSIBLE EXPOSURE LIMIT (PEL).** The maximum permitted 8-hour time-weighted-average concentration of an airborne contaminant. The exposure limits to be utilized are those published in DOL 29 CFR Part 1910.1000. The Recommended Exposure Limit (REL) concentrations published by the US National Institute for Occupational Safety and Health (NIOSH), Threshold Limit Value Time Weighted Average (TLV TWA) concentrations published by the American Conference of Governmental Industrial Hygienists (ACGIH), Workplace Environmental Exposure Level (WEEL) Guides published by the American Industrial Hygiene Association (AIHA), and other *approved*, consistent measures are allowed as surrogates for hazardous substances not *listed* in DOL 29 CFR Part 1910.1000.
- PESTICIDE.** A substance or mixture of substances, including fungicides, intended for preventing, destroying, repelling, or mitigating pests and substances or a mixture of substances intended for use as a plant regulator, defoliant or desiccant. Products defined as drugs in the Federal Food, Drug and Cosmetic Act are not pesticides.
- PHOTOVOLTAIC.** Relating to electricity produced by the action of solar radiation on a solar cell.
- PHOTOVOLTAIC ARRAY.** A mechanically integrated assembly of modules or panels with a support structure and foundation, tracker, and other components, as required, to form a power-producing unit.
- PHOTOVOLTAIC RACKING.** A system of components that directly supports the *photovoltaic modules* and transfers the applied *loads* to the building structure or ground-supported structure.
- PHOTOVOLTAIC SOLAR ENERGY SYSTEM.** The total components and subsystems that, in combination, convert solar energy into electric energy suitable for connection to a utilization load.

P
(continued)

PIER. A structure usually of greater length than width and projecting from the shore into a body of water with direct access from land that can be either open deck or provided with a superstructure.

PLUMBING CODE. For the purpose of the *Oregon Structural Specialty Code, Plumbing Code* shall mean the *Oregon Plumbing Specialty Code (OPSC)* as adopted by OAR 918-750-0110.

PLYWOOD AND VENEER MILLS. Facilities where raw wood products are processed into finished wood products, including waferboard, oriented strand board, fiberboard, composite wood panels and plywood.

POLYETHYLENE. A thermoplastic high-molecular-weight organic compound often used in sheet form as a water-vapor retarder.

POLYVINYL CHLORIDE (PVC). A synthetic resin used in the manufacture of pipes and nonmetallic waterstops.

PREFABRICATED CONSTRUCTION. See OAR Chapter 918, Division 674.

PREFORMED SEALANT. A sealant functionally preshaped by the manufacturer so that only minimum field fabrication is required prior to installation.

PRESSURE SENSITIVE. Capable of adhering to a surface when pressed against it, without the application of additional adhesives.

PRESSURE VESSEL. A closed vessel designed to operate at pressures above 15 psig (103 kPa).

PRIMARY CONTAINMENT. The first level of containment, consisting of the inside portion of a container that comes into immediate contact on its inner surface with the material being contained.

PRIMARY FUNCTION. A *primary function* is a major activity for which the *facility* is intended. Areas that contain a *primary function* include, but are not limited to, the customer services lobby of a bank, the dining area of a cafeteria, the meeting rooms in a conference center, as well as offices and other work areas in which the activities of the public accommodation or other private entity using the *facility* are carried out. Mechanical rooms, boiler rooms, supply storage rooms, employee lounges or locker rooms, janitorial closets, entrances, corridors and restrooms are not areas containing a *primary function*. See ORS 447.241(8).

PROCESS TRANSFER. The transfer of flammable or *combustible liquids* between tank vehicles or tank cars and process operations. Process operations may include containers, tanks, piping and equipment.

PROPELLANT. The liquefied or *compressed gas* in an *aerosol container* that expels the contents from an *aerosol container* when the valve is actuated. A propellant is considered flammable if it forms a flammable mixture with air or if a flame is self-propagating in a mixture with air.

PUBLIC ACCOMMODATIONS. See ORS 447.210(11).

PUBLIC BUILDING. Any building or structure that is publicly owned.

PUBLIC TRAFFIC ROUTE (PTR). Any public street, road, highway, navigable stream or passenger railroad that is used for through traffic by the general public.

PUBLIC USE. Interior or exterior rooms or spaces that are made available to the general public. Public use may be provided at a building or facility that is privately or publicly owned.

PUBLIC-USE AREAS. (Not adopted)

R

RACKING. A system of components that directly supports the photovoltaic modules and transfers the applied loads to the building structure or ground-supported structure.

RADON GAS. A naturally occurring, chemically inert radioactive gas that is not detectable by human senses. As a gas (soil gas), it can move readily through particles of soil and rock and can accumulate under the slabs and foundations of buildings where it can easily enter into the living space through construction cracks and openings.

RAW PRODUCT. A mixture of natural materials such as tree trimmings, brush trimmings, or waste logs and stumps.

RECONSTRUCTION. As it relates to the *state building code*, is the systematic process, act or manner of constructing or assembling an *existing building* in part or in whole and any system, device or equipment regulated by the *state building code*.

REFRIGERANT. The fluid used for heat transfer in a refrigeration system; the refrigerant absorbs heat and transfers it at a higher temperature and a higher pressure, usually with a change of state.

REFRIGERATING (REFRIGERATION) SYSTEM. A combination of interconnected refrigerant-containing parts constituting one closed refrigerant circuit in which a refrigerant is circulated for the purpose of extracting heat.

REHABILITATION. Any work, as described by the categories of work defined herein, undertaken in an *existing building*.

REMOTELY LOCATED, MANUALLY ACTIVATED SHUTDOWN CONTROL. A control system that is designed to initiate shutdown of the flow of gases or liquids that is manually activated from a point located some distance from the delivery system.

RELOCATABLE BUILDING. (Not adopted)

RESIDENT HOUSING AREA. Includes any *cell, cell complex, cell dormitory, cell tier, dayroom* or *housing unit*.

RESIDENTIAL CODE. For the purposes of this code, *Residential Code* shall mean the *Oregon Residential Specialty Code* as adopted by OAR 918-480-0005.

RESIN APPLICATION AREA. An area where reinforced plastics are used to manufacture products by hand lay-up or spray-fabrication methods.

RESTRAINT. Shall mean the physical retention of a person within a room, cell or holding facility by any means, or within a building by means of locked doors.

RETAIL DISPLAY AREA. The area of a Group M occupancy open for the purpose of viewing or purchasing merchandise offered for sale. Individuals in such establishments are free to circulate among the items offered for sale, which are typically displayed on shelves, racks or the floor.

ROLL COATING. The process of coating, spreading and impregnating fabrics, paper or other materials as they are passed directly through a tank or trough containing flammable or combustible liquids, or over the surface of a roller revolving partially submerged in a flammable or combustible liquid.

ROOF AREA. See “*Solar roof plane*.”

RUBBISH (TRASH). Combustible and noncombustible waste materials, including residue from the burning of coal; wood; coke or other combustible material; paper; rags; cartons; tin cans; metals; mineral matter; glass crockery; dust; and discarded refrigerators and heating, cooking or incinerator-type appliances.

S

SAFETY CAN. An approved container of not more than 5 gallon (19 L) capacity having a spring-closing lid and spout cover so designed that it will relieve internal pressure when subjected to fire exposure.

SEALANT. Any material used to seal joints or openings against the passage of solids, liquids or gases.

SECONDARY CONTAINMENT. That level of containment that is external to and separate from primary containment.

SEGREGATED. Storage in the same room or inside area, but physically separated by distance from incompatible materials.

SEISMIC FORCES. The loads, forces and requirements prescribed herein, related to the response of the building to earthquake motions, to be used in the analysis and design of the structure and its components. *Seismic forces* for existing buildings are considered either full or reduced, as provided in Section 3403.

SEISMIC HAZARD. See Section 1803 and ORS 455.447.

SEMICONDUCTOR FABRICATION FACILITY. A building or a portion of a building in which electrical circuits or devices are created on solid crystalline substances having electrical conductivity greater than insulators but less than conductors. These circuits or devices are commonly known as semiconductors.

SHELF STORAGE. Storage on shelves less than 30 inches (762 mm) deep with the distance between shelves not exceeding 3 feet (914 mm) vertically. For other shelving arrangements, see the requirements for rack storage.

SIGNAGE. Displayed verbal, symbolic, tactile or pictorial information.

SOIL-GAS RETARDER (Residential). A continuous membrane of 6-mil (0.15 mm) polyethylene or other equivalent material used to retard the flow of soil gases into a building.

SOIL-GAS-RETARDER MEMBRANE. A durable, flexible and nondeteriorating material installed in a continuous sheet to retard the pressure-driven flow of soil gas through elements of a structure.

SOLAR-READY ZONE. A section or sections of the roof or building overhang designated and reserved for the future installation of a solar photovoltaic system. The zone shall be exclusive of access, pathways, and setback areas.

SOLAR ROOF PLANE. A roof plane on which a *photovoltaic array* is installed. A *solar roof plane* does not include building integrated PV solar shingles.

Adjacent roof plane. For the purposes of firefighter access and escape pathway provisions, the *solar roof plane* is contrasted with the *adjacent roof plane*. To be considered an *adjacent roof plane*, the *roof plane adjacent* to the *photovoltaic array* installation must be free of *photovoltaic panels*.

In typical gable roof construction, the south facing roof will generally be the preferred place for the installation of *photovoltaic panels* and it will become the *solar roof plane*. Where the north-facing roof plane does not contain any *photovoltaic panels*, it would be considered the *adjacent roof plane*.

Roof area. The square footage of roof measured in plan view separated by *fire walls* or *exterior walls* and sharing a common *attic* or *fire area* below.

SOLID REINFORCED MASONRY. Masonry construction in which mortar, grout or concrete completely fills all joints and voids and in which steel reinforcement is embedded in such a manner that the materials act together in resisting forces.

S
(continued)

SOLID SHELVING. Shelving that is solid, slatted or of other construction located in racks and which obstructs sprinkler discharge down into the racks.

SOLVENT DISTILLATION UNIT. An appliance that receives contaminated flammable or combustible liquids and which distills the contents to remove contaminants and recover the solvents.

SOLVENT OR LIQUID CLASSIFICATIONS. A method for classifying solvents or liquids according to the following classes:

Class I solvents. Liquids having a flash point below 100°F (38°C).

Class II solvents. Liquids having a flash point at or above 100°F (38°C) and below 140°F (60°C).

Class IIIA solvents. Liquids having a flash point at or above 140°F (60°C) and below 200°F (93°C).

Class IIIB solvents. Liquids having a flash point at or above 200°F (93°C).

Class IV solvents. Liquids classified as nonflammable.

SPACE. A definable area (e.g., room, toilet room, hall, assembly area, entry, storage room, alcove, courtyard or lobby).

SPECIAL FLOOD HAZARD AREA. The land area subject to flood hazards and shown on a Flood Insurance Rate Map or other flood hazard map as established by the flood plain administrator—Zone A, AE, A1-30, A99, AR, AO, AH, V, VO, VE or V1-30.

SPRAY BOOTH. A mechanically ventilated appliance of varying dimensions and construction provided to enclose or accommodate a spraying operation and to confine and limit the escape of spray vapor and residue and to exhaust it safely.

SPRAYING SPACE. An area in which dangerous quantities of flammable vapors or combustible residues, dusts or deposits are present due to the operation of spraying processes. The fire official is authorized to define the limits of the spraying space in any specific case.

STATE BUILDING CODE. The combined specialty codes adopted pursuant to ORS 455 and any code regulation or requirement in effect at the time of construction—regardless of when the building or structure was built.

STATIONARY BATTERY ARRAY. An arrangement of individual stationary storage batteries in close proximity to each other, mounted on storage racks or in modules, battery cabinets or other enclosures.

STATIONARY STORAGE BATTERY SYSTEM. See “Battery system, stationary storage.”

STRUCTURE. That which is built or constructed. A structure may contain one or more buildings separated by fire-rated construction elements in accordance with state building code.

SUBGRADE. The soil prepared and compacted to support a structure.

SUBMEMBRANE DEPRESSURIZATION SYSTEM. A system designed to achieve lower-submembrane air pressure relative to crawl space air pressure by use of a vent drawing air from beneath the soil-gas-retarder membrane.

SUBORDINATE (FIRE PROTECTION AND LIFE SAFETY SYSTEM). A system that is activated by another fire protection or life safety system. For example, where a fire alarm system activates a smoke removal or elevator recall system, the smoke removal or elevator recall system is considered to be “subordinate” to the fire alarm system.

S
(continued)

SUBSLAB DEPRESSURIZATION SYSTEM.

Active. A system designed to achieve lower subslab air pressure relative to indoor air pressure by use of a fan-powered vent drawing air from beneath the slab.

Passive. A system designed to achieve lower subslab air pressure relative to indoor air pressure by use of a vent pipe routed through the conditioned space of a building and connecting the subslab area with outdoor air, thereby relying on the convective flow of air upward in the vent to draw air from beneath the slab.

SUBSTANTIAL ALTERATION. Any alteration to an existing Group R-2 apartment house, where the total cost of all alterations (including, but not limited to, electrical, mechanical, plumbing or structural changes) for a building or facility within any 12-month period amounts to 25 percent or more of the assessed value of the structure before the building alteration occurred. For the purpose of this code, standard building maintenance, rewiring, residing or reroofing are not considered an alteration.

SUBSTANTIAL DAMAGE.

Flood. For the purpose of determining compliance with the flood provisions of this code, damage of any origin sustained by a structure whereby the cost of restoring the structure to its before-damaged condition would equal or exceed 50 percent of the market value of the structure before the damage occurred.

Group R-2 apartment house. Any damage of any origin to an existing Group R-2 apartment house, whereby the cost of restoring the structure to its original condition would be equal to or exceed 25 percent of the assessed value of the structure before the damage occurred.

SUBSTANTIAL IMPROVEMENT. For the purpose of determining compliance with the flood provisions of this code, any repair, rehabilitation, alteration, addition or other improvement of a building or structure, the cost of which equals or exceeds 50 percent of the market value of the structure before the improvement or repair is started. If the structure has sustained *substantial damage*, any repairs are considered *substantial improvement* regardless of the actual *repair* work performed. The flood plain administrator shall make all final determinations in the application of this definition. The term does not, however, include either:

1. Any project for improvement of a building required to correct existing health, sanitary or safety code violations identified by the *building official* and that are the minimum necessary to assure safe living conditions.
2. Any *alteration* of a historic structure provided that the *alteration* will not preclude the structure's continued designation as a historic structure.

SUBSTANTIAL STRUCTURAL DAMAGE. A condition where any of the following apply:

1. The vertical elements of the lateral force-resisting system have suffered damage such that the lateral load-carrying capacity of any story in any horizontal direction has been reduced by more than 33 percent from its predamage condition.
2. The capacity of any vertical component carrying gravity load, or any group of such components, that has a tributary area more than 30 percent of the total area of the structure's floor(s) and roof(s) has been reduced more than 20 percent from its predamage condition, and the remaining capacity of such affected elements, with respect to all dead and live loads, is less than 75 percent of that required by this code for new buildings of similar structure, purpose and location.
3. The capacity of any structural component carrying snow load, or any group of such components, which supports more than 30 percent of the roof area of similar construction has been reduced more than 20 percent from its predamage condition, and the remaining capacity with respect to dead, live and snow loads is less than 75 percent of that required by this code for new buildings of similar structure, purpose and location.

SUPERPLASTICIZER. See "High-range water reducer."

SUPERSTRUCTURE. That portion of the construction of a pier or wharf above the deck. See Section 457.

S
(continued)

SUPPORTS. Supports, hangers and anchors are devices for properly supporting and securing pipe, appurtenances, fixtures and equipment.

SYSTEM. An assembly of equipment consisting of a tank, container or containers, appurtenances, pumps, compressors and connecting piping.

T

TANK. A vessel containing more than 60 gallons (227 L).

TANK, ATMOSPHERIC. A storage tank designed to operate at pressures from atmospheric through 1.0 pound per square inch gauge (760 mm Hg through 812 mm Hg), measured at the top of the tank.

TANK, PORTABLE. A packaging of more than 60-gallon (227 L) capacity and designed primarily to be loaded into or on or temporarily attached to a transport vehicle or ship and equipped with skids, mountings or accessories to facilitate handling of the tank by mechanical means. It does not include any cylinder having less than a 1,000-pound (454 kg) water capacity, cargo tank, tank car tank or trailers carrying cylinders of more than 1,000-pound (454 kg) water capacity.

TANK, PRIMARY. A listed atmospheric tank used to store liquid. See “Primary containment.”

TANK, PROTECTED ABOVE GROUND. A tank listed in accordance with UL 2085 consisting of a primary tank provided with protection from physical damage and fire-resistive protection from a high-intensity liquid pool fire exposure. The tank may provide protection elements as a unit or may be an assembly of components, or a combination thereof.

TANK, STATIONARY. Packaging designed primarily for stationary installations not intended for loading, unloading or attachment to a transport vehicle as part of its normal operation in the process of use. It does not include cylinders having less than a 1,000-pound (454 kg) water capacity.

TANK VEHICLE. A vehicle other than a railroad tank car or boat, with a cargo tank mounted thereon or built as an integral part thereof, used for the transportation of flammable or combustible liquids, LP-gas or hazardous chemicals. Tank vehicles include self-propelled vehicles and full trailers and semitrailers, with or without motive power, that carry part or all of the load.

TECHNICALLY INFEASIBLE. An alteration that has little likelihood of being accomplished because existing structural conditions would require removing or altering a load-bearing member that is an essential part of the structural frame, or because site constraints prohibit modification or addition of elements, spaces or features that are in full and strict compliance with the minimum requirements for new construction and are necessary to provide accessibility.

TEMPORARY SPECIAL EVENT STRUCTURE. Any temporary ground-supported structure, platform, stage, stage scaffolding or rigging, canopy, tower supporting audio or visual effects equipment or similar structures.

TEMPORARY STRUCTURE. A structure that is erected, occupied, and disassembled or otherwise removed from the site within a total time period of 180 calendar days or less.

TIMBER AND LUMBER PRODUCTION FACILITIES. Facilities where raw wood products are processed into finished wood products.

TOOL. A device, storage container, workstation or process machine used in a fabrication area.

TOTAL SOLAR RESOURCE FRACTION (TSRF). The amount of sunlight a solar-ready zone will receive over the year, expressed as the percent of energy produced by a fixed axis solar energy system when compared to the annual performance of the same system with optimal tilt and orientation and no external shading.

TRANSVERSE FLUE SPACE. See “Flue spaces—Transverse.”

TRASH. See “Rubbish.”

TSUNAMI RISK CATEGORY III. The categorization for design of Risk Category III buildings and other structures located within the Tsunami Design Zone. See Section 1615 and ORS 455.447.

TSUNAMI RISK CATEGORY IV. The categorization for design of Risk Category IV buildings and other structures located within the Tsunami Design Zone. See Section 1615 and ORS 455.447.

U **UNAUTHORIZED DISCHARGE.** A release or emission of materials in a manner that does not conform to the provisions of this code or applicable public health and safety regulations.

UNSAFE. Buildings that are deficient due to inadequate means of egress facilities, or that constitute a fire hazard, or in which the structure or individual structural members meet the definition of “Dangerous,” or that are otherwise dangerous to human life or that involve illegal or improper occupancy.

V **VAPOR PRESSURE.** The pressure exerted by a volatile fluid as determined in accordance with ASTM D323.

VESSEL. A motorized watercraft, other than a seaplane on the water, used or capable of being used as a means of transportation. Nontransportation vessels, such as houseboats and boathouses, are included in this definition.

W **WATER MIST SYSTEM, AUTOMATIC.** See “Automatic water mist system.”

WATERPROOFING MEMBRANE. A liquid sealing compound (e.g., bituminous and paraffinic emulsions, coal tar cutbacks) or nonliquid protective coating (e.g., sheet plastics) used separately or together in a manner that renders the structural surface to which they are applied essentially impervious to water in either the liquid or vapor state.

WATER-REDUCING ADMIXTURE. A chemical additive to concrete conforming to ASTM C94 capable of producing a reduction in mixing water or increase in flowability without causing undue set retardation or entrainment of air in the mortar or concrete.

WATERSTOP. A diaphragm used across a joint as a sealant, usually manufactured specifically to prevent the passage of water through joints in concrete structures.

WHARF. A structure at the shoreline having a platform built alongside and parallel to a body of water that may have an open deck or be provided with a superstructure.

WINDBORNE DEBRIS REGION. (Not adopted)

WINERY. A facility used for the primary commercial purpose of processing grapes or other fruit products to produce wine or cider having a 16 percent or less alcohol content by volume, including all areas used for the production, storage, distribution and sale of such wine or cider, including crushing, fermenting in wood or steel barrels, blending, aging, bottling, warehousing, shipping and tasting rooms with an occupant load of 299 or less and retailing of wine, cider and incidental items related to wine and cider and all associated administrative functions.

WORK AREA. That portion or portions of a building consisting of all reconfigured spaces as indicated on the construction documents. Work area excludes other portions of the building where incidental work entailed by the intended work must be performed and portions of the building where work not initially intended by the owner is specifically required by this code.

WORKING LEVEL (WL). A measure of radioactive exposure equal to the total quantity of radon decay products in 1 liter of air that will result in the ultimate emission of 1.3×10^5 MeV (million electron volts) of energy from alpha particles. In perfect equilibrium, 1 WL equals 100 pCi/L (picoCuries per liter). It is often assumed that the air inside buildings is not in equilibrium, and that only half the radon daughters are moving freely in the air, while half are attached to dust or building surfaces. Where this condition exists, an equilibrium ratio of 0.5 is said to exist. At an equilibrium ratio of 0.5, 1 WL = 200 pCi/L. For purposes of this standard, 1 WL is defined as equal to 200 pCi/L.

CHAPTER 3

OCCUPANCY CLASSIFICATION AND USE

Section 302 Occupancy Classification and Use Designation

- IBC 302.1 **302.1 Occupancy classification.** *(All of 302.1 but item 9 remains unchanged)*
9. Storage (see Section 311): Groups S-1, ~~and S-2~~ and S-3.

Section 304 Business Group B

- OSSC 304.5 **304.5 Lockup facilities.** Buildings containing lockup facilities, as defined in ORS 169.005(4), shall comply with the following provisions:
1. Areas containing lockup facilities shall be separated from other rooms, spaces or areas by an approved smoke barrier.
 2. The smoke control zone in which the lockup cells are located shall be provided with an automatic sprinkler system complying with Chapter 9 requirements for Group I-3 occupancies.
 3. The smoke control zone in which the lockup area is located shall be provided with an automatic smoke detection system complying with Chapter 9 requirements for Group I-3 occupancies.
 4. The combined occupant load of the holding cells shall not exceed five.

Section 305 Educational Group E

- OSSC 305.2.3 **305.2.3 Five or fewer children in a dwelling unit.** A facility such as the above located within a *dwelling unit* and having five or fewer children receiving such day care shall be classified as a Group R-3 occupancy ~~or shall comply with the International Residential Code.~~ Where located within a detached one- or two-family dwelling or townhouse, the facility shall be permitted to be constructed in accordance with the Residential Code, provided that Section 420.12 is met, and accessibility is provided in accordance with Section 1103.2.12 for newly constructed facilities and Section 3403.4 for existing facilities.
- IBC 305.3 **305.3 Storm shelters in Group E occupancies.** *(Not adopted)*

Section 306 Factory Group F

- OSSC 306.3 **306.3 Low-hazard factory industrial, Group F-2.** Factory industrial uses that involve the fabrication or manufacturing of noncombustible materials that during finishing, packing or processing do not involve a significant fire hazard shall be classified as F-2 occupancies and shall include, but not be limited to, the following: *(The rest of 306.3 remains unchanged)*
- Wood barrel and bottled wine aging facilities in wineries

Section 307 High-Hazard Group H

- OSSC 307.1 **307.1 High-hazard Group H.** High-hazard Group H occupancy includes, among others, the use of a building or structure, or a portion thereof, that involves the manufacturing, processing, generation or storage of materials that constitute a physical or health hazard in quantities in excess of those allowed in *control areas* complying with Section 414, based on the maximum allowable quantity limits for *control areas* set forth in Tables 307.1(1) and 307.1(2). Hazardous occupancies are classified in Groups H-1, H-2, H-3, H-4 and H-5 and shall be in accordance with this section, and the requirements of Section 415 ~~and the International Fire Code.~~ Hazardous materials stored, or used on top of roofs or canopies, shall be classified as outdoor storage or use and shall comply with the International Fire Code this code.

- OSSC 307.2.1 [307.2.1 Storage of Class 1.4G \(Class C, Common\) fireworks.](#) [A permanent building used for the temporary storage of 1.4G \(Class C\) fireworks, as authorized by a retail sales permit under ORS 480.127, may be classified as either a Group M, Group S-1 or a detached Group U occupancy, provided that:](#)
- [1. The total amount of 1.4G retail fireworks is less than 5,000 pounds \(2268 kg\) gross weight; or](#)
 - [2. Where the building is protected by an *approved automatic sprinkler system* and the amount of 1.4G retail fireworks is less than 10,000 pounds \(4536 kg\) gross weight.](#)

Section 308 Institutional Group I

- IBC 308.2 **308.2 Institutional Group I-1.** Institutional Group I-1 occupancy shall include buildings, structures or portions thereof for more than 16 persons, excluding staff, who reside on a *24-hour* basis in a supervised environment and receive custodial care. Buildings of Group I-1 shall be classified as one of the occupancy conditions specified in Section 308.2.1 or 308.2.2 and shall comply with Section 420. ~~This group shall include, but not be limited to, the following:~~

~~Alcohol and drug centers~~
~~Assisted living facilities~~
~~Congregate care facilities~~
~~Group homes~~
~~Halfway houses~~
~~Residential board and care facilities~~
~~Social rehabilitation facilities~~

308.2.1 Condition 1. This occupancy condition shall include buildings in which all persons receiving custodial care who, without any assistance, are capable of responding to an emergency situation to complete building evacuation.

~~This group shall include, but not be limited to, the following:~~

~~Congregate living facilities~~
~~Halfway houses~~
~~Social rehabilitation facilities~~

308.2.2 Condition 2. This occupancy condition shall include buildings [subject to licensure by the Oregon Department of Human Services](#) in which there are any persons receiving custodial care who require limited verbal or physical assistance while responding to an emergency situation to complete building evacuation. ~~This group shall include, but not be limited to, the following:~~

~~Alcohol and drug centers~~
~~Assisted living facilities with or without a Memory Care Endorsement~~
~~Residential care facilities with or without a Memory Care Endorsement~~
~~Residential treatment facilities~~
~~Group homes and facilities~~

308.2.4 Five or fewer persons receiving custodial care. A facility with five or fewer persons receiving custodial care [located within a dwelling](#) shall be classified as Group R-3 ~~and-or~~ shall comply with the ~~International Residential Code~~ provided ~~that~~ [an automatic sprinkler system is installed in accordance with Section 903.3.1.3-or Section P2904 of the International Residential Code](#) and accessibility is provided in accordance with the applicable provisions of Chapter 11 for the function served.

- IBC 308.3.2 **308.3.2 Five or fewer persons receiving medical care.** A facility with five or fewer persons receiving medical care [located within a dwelling](#) shall be classified as Group R-3 ~~and-or~~ shall comply with the ~~International Residential Code~~ provided ~~that~~ [an automatic sprinkler system is installed in accordance with Section 903.3.1.3-or Section P2904 of the International Residential Code](#) and accessibility is provided in accordance with the applicable provisions of Chapter 11 for the function served.

- IBC 308.5.4** **308.5.4 Five or fewer persons receiving adult day care in a dwelling unit.** A facility such as the above within a *dwelling-unit* and having five or fewer persons receiving *custodial care* shall be classified as a Group R-3 occupancy ~~or shall comply with the *International Residential Code* and shall be permitted to be constructed in accordance with the *Residential Code* provided that an *automatic sprinkler system* is installed in accordance with Section 903.3.1.3 and accessibility is provided in accordance with the applicable provisions of Chapter 11 for the function served.~~
- OSSC 308.5.5** **308.5.5 Child day care in a dwelling unit.** A registered or certified family child care facility, as defined in ORS 329A, located within a *dwelling* shall be classified as a Group R-3 occupancy. Where located within a detached one- or two-family *dwelling* or *townhouse*, the facility shall be permitted to be constructed in accordance with the *Residential Code*, provided that Section 420.12 is met, and accessibility is provided in accordance with Section 1103.2.12 for newly constructed facilities and Section 3403.4 for existing facilities.

Section 310 Residential Group R

- IBC 310.1** **310.1 Residential Group R.** Residential Group R includes, among others, the use of a building or structure, or a portion thereof, for sleeping purposes when not classified as an Institutional Group I or when not regulated by the *International Residential Code*. ~~Group R occupancies not constructed in accordance with the *International Residential Code* as permitted by Sections 310.4.1 and 310.4.2 shall comply with Section 420.~~
- IBC 310.3** **310.3 Residential Group R-2.** Residential Group R-2 occupancies containing *sleeping units* or more than two *dwelling units* where the occupants are primarily permanent in nature, including: *(The rest of 310.3 remains unchanged)*
- Group R-2 occupancies providing 21 or more housing units for low-income elderly, which are financed in whole or in part by federal or state funds, shall contain a multiservice room adequate in size to seat all the tenants (ORS 455.425). The multiservice room shall include adjacent toilet facilities for both sexes; a service area with a kitchen sink, countertop, and upper and lower cabinets; and a storage room sized to store tables, chairs or benches, and janitorial supplies and tools. The multiservice room and accessory rooms shall be accessible in accordance with Chapter 11.
- IBC 310.4.1** **310.4.1 Care facilities within a dwelling.** ~~Care facilities for~~ A care facility located within a detached one- or two-family *dwelling* or *townhouse* and having five or fewer persons receiving care ~~that are within a single-family dwelling are~~ shall be permitted to ~~comply~~ be constructed in accordance with the *International Residential Code*, provided that Section 420.12 is met, ~~an automatic sprinkler system is installed in accordance with Section 903.3.1.3 or Section P2904 of the *International Residential Code*~~ accessibility is provided in accordance with Section 1103.2.12 for newly constructed facilities and Section 3403.4 for existing facilities.
- OSSC 310.4.2** **310.4.2 Licensed child care within a dwelling.** A registered or certified family child care facility, as defined in ORS 329A, located within a *dwelling* shall be classified as a Group R-3 occupancy. Where located within a one- or two-family *dwelling* or *townhouse* the care facility shall be permitted to be constructed in accordance with the *Residential Code*, provided that Section 420.12 is met, and accessibility is provided in accordance with Section 1103.2.12 for newly constructed facilities and Section 3403.4 for existing facilities.
- OSSC 310.4.3** **310.4.3 Licensed adult foster care within a dwelling.** Adult foster homes, as defined in ORS 443.705, located within a *dwelling* shall be classified as Group R-3 and shall be permitted to be constructed in accordance with the *Residential Code* provided that an *automatic sprinkler system* is installed in accordance with Section 903.3.1.3 and accessibility is provided in accordance with the applicable provisions of Chapter 11 for the function served.

Adult foster homes and residential training homes within detached one-family dwellings. Adult foster homes as defined in ORS 443.705 and residential training homes as defined in ORS 443.400 licensed for five or fewer individuals prior to July 1, 2024, shall not require the installation of an automatic fire sprinkler system under application of the state building code. See the enrolled Senate Bill 1548 [2022] at Oregonlegislature.gov for more details.

IBC 310.4.2 ~~**310.4.4**~~ ~~**310.4.2**~~ **Lodging houses.** Owner-occupied *lodging houses* with five or fewer *guest rooms* and 10 or fewer total occupants, and are located within a detached one-family dwelling shall be permitted to be constructed in accordance with the ~~*International Residential Code*~~, provided that an ~~*automatic sprinkler system*~~ is installed in accordance with ~~Section 903.3.1.3 or Section P2904 of the *International Residential Code*~~.

IBC 310.5 **310.5 Residential Group R-4.** Residential Group R-4 occupancy shall include buildings, structures or portions thereof for more than five but not more than 16 persons, excluding staff, who reside on a 24-hour basis in a supervised residential environment and receive *custodial care*. Buildings of Group R-4 shall be classified as one of the occupancy conditions specified in Section 310.5.1 or 310.5.2. ~~This group shall include, but not be limited to, the following:~~

~~Alcohol and drug centers
Assisted living facilities
Congregate care facilities
Group homes
Halfway houses
Residential board and care facilities
Social rehabilitation facilities~~

Group R-4 occupancies shall meet the requirements for construction as defined for Group R-3, except as otherwise provided for in this code.

310.5.1 Condition 1. This occupancy condition shall include buildings in which all persons receiving custodial care, without any assistance, are capable of responding to an emergency situation to complete building evacuation. This group shall include, but not be limited to, the following:

Congregate living facilities
Halfway houses
Social rehabilitation facilities

310.5.2 Condition 2. This occupancy condition shall include buildings subject to licensure by the Oregon Department of Human Services in which there are any persons receiving custodial care who require limited verbal or physical assistance while responding to an emergency situation to complete building evacuation. This group shall include, but not be limited to, the following:

Alcohol and drug centers
Assisted living facilities with or without a Memory Care Endorsement
Residential care facilities with or without a Memory Care Endorsement
Residential treatment facilities
Group homes and facilities

Section 311 Storage Group S

IBC 311.1.1 **311.1.1 Accessory storage spaces.** A room or space used for storage purposes that is accessory to another occupancy ~~shall~~ may be classified as part of that occupancy.

IBC 311.3 **311.3 Low-hazard storage, Group S-2.** Storage Group S-2 occupancies include, among others, buildings used for the storage of noncombustible materials such as products on wood pallets or in paper cartons with or without single thickness divisions; or in paper wrappings. Such products are permitted to have a negligible amount of plastic *trim*, such as knobs, handles or film wrapping. Group S-2 storage uses shall include, but not be limited to, storage of the following: *(The remainder of 311.3 remains unchanged)*

Beverages up to and including 16-percent alcohol in wood barrels, metal, glass or ceramic containers

OSSC 311.4 **311.4 Mausoleums and columbariums, Group S-3.** Storage Group S-3 occupancies include, among others, mausoleums and columbariums. Except where specific provisions are made in Sections 458, other requirements of this code shall apply.

CHAPTER 4

SPECIAL DETAILED REQUIREMENTS BASED ON OCCUPANCY AND USE

Section 401 Scope

IBC 401.1

Boilers, pressure vessels and associated piping are regulated by the *Boiler Code* and expressly administered and enforced by the State of Oregon, Building Codes Division, Boiler and Pressure Vessel Code Program. Codes and standards adopted as part of the *Boiler Code* have been excluded from this code.

Those codes and standards include, but are not limited to, ANSI/ASME B31.1 Power Piping, ANSI/ASME B31.3 Process Piping, ANSI/ASME B31.5 Refrigeration Piping, and ANSI/ASME B31.9 Building Service Piping.

Section 403 High-Rise Buildings

IBC 403.4.6 **403.4.6 Fire command.** A fire command center complying with Section 911 shall be provided in a location approved by the fire ~~code~~-official.

Section 404 Atriums

IBC 404.2 **404.2 Use.** The floor of the atrium shall not be used for other than low fire hazard uses and only approved materials ~~and decorations~~ in accordance with this code ~~the International Fire Code~~ shall be used in the atrium space. *(The exception remains unchanged)*

Section 406 Motor-Vehicle-Related Occupancies

IBC 406.6.4.3 **406.6.4.3 Fire control equipment room.** Fire control equipment, consisting of the fire alarm control unit, mechanical ventilation controls and an emergency shutdown switch, shall be provided in a room located where the equipment is able to be accessed by the fire service from a secured exterior door of the building. The room shall not be less than 50 square feet (4.65 m²) in area and shall be in an approved location ~~that is approved by the fire code official.~~

IBC 406.6.4.3.1 **406.6.4.3.1 Emergency shutdown switch.** The mechanical parking system shall be provided with a manually activated emergency shutdown switch for use by emergency personnel. The switch shall be clearly identified and shall be in an approved location ~~approved by the fire code official.~~

IBC 406.7 **406.7 Motor fuel-dispensing facilities.** Motor fuel-dispensing facilities, marine motor fuel-dispensing facilities, fleet vehicle motor fuel-dispensing facilities, and aircraft motor-vehicle fuel-dispensing facilities shall comply with Sections 406.2 and 406.7 and the other applicable provisions of this code. Such operations shall include both those that are open to the public and private operations.

406.7.1 Indoor motor fuel-dispensing facilities. Motor fuel-dispensing facilities located inside buildings shall comply with this code and NFPA 30A.

406.7.1.1 Protection of floor openings in indoor motor fuel-dispensing facilities. Where motor fuel-dispensing facilities are located inside buildings and the dispensers are located above spaces within the building, openings beneath dispensers shall be sealed to prevent the flow of leaked fuel to lower building spaces.

406.7.1.2 ~~**406.7.1**~~ **Vehicle fueling pad.**

Renumbered

IBC 406.7.2 Canopies.

Remains unchanged

IBC 406.7.2.1 Canopies used to support gaseous hydrogen systems.

Remains unchanged

406.7.3 Above-ground tanks located inside buildings. Above-ground tanks for the storage of Class I, II and IIIA liquid fuels are allowed to be located in buildings. Such tanks shall be located in special enclosures complying with Section 406.7.4.1 in a liquid storage room or a *liquid storage warehouse* complying with this chapter or shall be *listed* and *labeled* as protected above-ground tanks in accordance with UL 2085.

406.7.3.1 Special enclosures. Where installation of tanks underground is impractical, or because of property or building limitations, tanks for liquid motor fuels are allowed to be installed in buildings in special enclosures in accordance with all of the following:

1. The special enclosure shall be liquid tight and vapor tight.
2. The special enclosure shall not contain backfill.
3. Sides, top and bottom of the special enclosure shall be of reinforced concrete not less than 6 inches (152 mm) thick, with openings for inspection through the top only.
4. Tank connections shall be piped or closed such that neither vapors nor liquid can escape into the enclosed space between the special enclosure and any tanks inside the special enclosure.
5. Means shall be provided whereby portable equipment can be employed to discharge outdoors any vapors that might accumulate inside the special enclosure should leakage occur.
6. Tanks containing Class I, II or IIIA liquids inside a special enclosure shall not exceed 6,000 gallons (22,710 L) in individual capacity or 18,000 gallons (68,130 L) in aggregate capacity.
7. Each tank within a special enclosure shall be surrounded by a clear space of not less than 3 feet (910 mm) to allow for maintenance and inspection.

406.7.4 Physical protection. Guard posts complying with Section 912.4.4 or other *approved* means shall be provided to protect above-ground tanks against impact by a motor vehicle unless the tank is *listed* as a protected aboveground tank with vehicle impact protection.

406.7.5 Secondary containment. Above-ground tanks shall be provided with drainage control or diking in accordance with this chapter. Drainage control and diking are not required for *listed secondary containment* tanks. *Secondary containment systems* shall be monitored either visually or automatically. Enclosed *secondary containment systems* shall be provided with emergency relief venting in accordance with Section 406.7.6.2.5.

406.7.6 Ancillary equipment for use with flammable or combustible liquids. The design, fabrication, assembly, testing and inspection of ancillary equipment for use with flammable or combustible liquids shall be in accordance with Sections 406.7.6.1 through 406.7.6.2.6 and the other applicable sections of this chapter.

406.7.6.1 Protection from damage. Piping shall be located such that it is protected from physical damage.

406.7.6.2 Ancillary equipment for above-ground tanks for Class I, II and III liquids. Ancillary equipment for above-ground tanks storing Class I, II and III liquids shall comply with Sections 406.7.6.2.1 through 406.7.6.2.6.

406.7.6.2.1 Tank openings. Tank openings for above-ground tanks shall be through the top only.

406.7.6.2.2 Fill-pipe connections. The fill pipe for above-ground tanks shall be provided with a means for making a direct connection to the tank vehicle's fuel-delivery hose so that the delivery of fuel is not exposed to the open air during the filling operation. Where any portion of the fill pipe exterior to the tank extends below the level of the top of the tank, a check valve shall be installed in the fill pipe not more than 12 inches (305 mm) from the fill-hose connection.

406.7.6.2.3 Overfill protection. Overfill protection shall be provided for above-ground flammable and *combustible liquid* storage tanks in accordance with Sections 444.4.1.5.5.7 and 444.4.1.7.5.5.

406.7.6.2.4 Siphon prevention. An *approved* antisiphon method shall be provided in the piping system to prevent flow of liquid by siphon action.

406.7.6.2.5 Emergency relief venting. Aboveground storage tanks, tank compartments and enclosed *secondary containment* spaces shall be provided with emergency relief venting in accordance with this chapter.

406.7.6.2.6 Spill containers. A spill *container* having a capacity of not less than 5 gallons (19 L) shall be provided for each fill connection. For tanks with a top fill connection, spill *containers* shall be noncombustible and shall be fixed to the tank and equipped with a manual drain valve that drains into the primary tank. For tanks with a remote fill connection, a portable spill *container* is allowed.

406.7.7 Hydrogen motor fuel-dispensing and generation facilities. Hydrogen motor fuel-dispensing and generation facilities shall be in accordance with this code.

406.7.7.1 Location of operations and equipment. Generation, compression, storage and dispensing equipment shall be located in accordance with Sections 406.7.7.1.1 through 406.7.7.1.4.5.

406.7.7.1.1 Indoor. Generation, compression, storage and dispensing equipment shall be located in indoor rooms or areas constructed in accordance with the requirements of this code, the *Mechanical Code* and NFPA 2.

406.7.7.1.1.1 Smoking. Smoking shall be prohibited in hydrogen cutoff rooms. “No Smoking” signs shall be provided at all entrances to hydrogen fuel gas rooms.

406.7.7.1.2 Gaseous hydrogen storage. Storage of gaseous hydrogen shall be in accordance with Sections 440 and 445.

406.7.7.1.3 Liquefied hydrogen storage. Storage of liquefied hydrogen shall be in accordance with Sections 440 and 445.

406.7.7.1.4 Canopy tops. Gaseous hydrogen compression and storage equipment located on top of motor fuel-dispensing facility canopies shall be in accordance with Sections 406.7.7.1.4.1 through 406.7.7.1.4.5, Sections 440 and 445, and the *Mechanical Code*.

406.7.7.1.4.1 Construction. Canopies shall be constructed in accordance with the motor fuel-dispensing facility canopy requirements of Section 406.7.2 and 406.7.2.1.

406.7.7.1.4.2 Fire-extinguishing systems. Fuel-dispensing areas under canopies shall be equipped throughout with an *approved automatic sprinkler system* in accordance with Section 903.3.1.1. The design of the sprinkler system shall be not less than that required for Extra Hazard Group 2 occupancies. Operation of the sprinkler system shall activate the emergency functions of Sections 406.7.7.1.4.3 and 406.7.7.1.4.4.

406.7.7.1.4.3 Emergency discharge. Operation of the *automatic sprinkler system* shall activate an *automatic emergency discharge system*, which will discharge the hydrogen gas from the equipment on the canopy top through the vent pipe system.

406.7.7.1.4.4 Emergency shutdown control. Operation of the *automatic sprinkler system* shall activate the emergency shutdown control.

406.7.7.1.4.5 Signage. *Approved signage* having 2-inch (51 mm) block letters shall be affixed at *approved locations* on the exterior of the canopy structure stating: CANOPY TOP HYDROGEN STORAGE.

406.7.7.1.5 Canopies. Dispensing equipment need not be separated from canopies of Type I or II construction that are constructed in a manner that prevents the accumulation of hydrogen gas and in accordance with Section 406.7.2 and 406.7.2.1.

406.7.8 Marine motor fuel-dispensing facilities. The construction of marine motor fuel-dispensing facilities shall be in accordance with this code and NFPA 30A. The storage of Class I, II or IIIA liquids at marine motor fuel-dispensing facilities shall be in accordance with this code.

406.7.8.1 Storage. The storage of Class I, II or IIIA liquids at marine motor fuel-dispensing facilities shall be in accordance with Sections 406.7.8.1.1 through 406.7.8.1.3.

406.7.8.1.1 Class I, II or IIIA liquid storage. Class I, II or IIIA liquids stored inside buildings used for marine motor fuel-dispensing facilities shall be stored in *approved containers* or *portable tanks*. Storage of Class I liquids shall not exceed 10 gallons (38 L).

Exception: Storage in liquid storage rooms in accordance with Section 444.4.7.

406.7.8.1.2 Class II or IIIA liquid storage. Class II or IIIA liquids stored inside buildings used for marine motor fuel-dispensing facilities shall be stored in *approved containers* or *portable tanks*. Storage of Class II and IIIA liquids shall not exceed 120 gallons (454 L).

406.7.8.1.3 Heating equipment. Heating equipment installed in Class I, II or IIIA liquid storage or dispensing areas shall comply with this code and the *Mechanical Code*.

IBC 406.8 **406.8 Repair garages.** *Replaced with the following:*

~~406.8 Repair garages. Repair garages shall be constructed in accordance with Sections 406.2 and this section. This occupancy shall not include motor fuel-dispensing facilities, as regulated in Section 406.7. Repair garages for vehicles that use more than one type of fuel shall comply with the applicable provisions of this section for each type of fuel used.~~

~~406.8.1 Ventilation. Repair garages shall be mechanically ventilated in accordance with the *International Mechanical Code*. The ventilation system shall be controlled at the entrance to the garage.~~

~~406.8.2 406.8.3 Automatic sprinkler system. A repair garage shall be equipped with an automatic sprinkler system in accordance with Section 903.2.9.1.~~

~~406.8.3 Storage of flammable and combustible liquids. The storage and use of flammable and combustible liquids in repair garages shall comply with Section 444 and Sections 406.8.3.1 through 406.8.3.2.~~

~~406.8.3.1 Waste oil, motor oil and other Class IIIB liquids. Waste oil, motor oil and other Class IIIB liquids shall be stored in approved tanks or containers, which are allowed to be stored and dispensed from inside repair garages.~~

~~406.8.3.1.1 Tank location. Tanks storing Class IIIB liquids in repair garages are allowed to be located at, below or above grade, provided that adequate drainage or containment is provided.~~

~~406.8.3.2 Spray finishing. Spray finishing with flammable or combustible liquids shall comply with this code.~~

~~406.8.4 Sources of ignition. Sources of ignition shall not be located within 18 inches (457 mm) of the floor and shall comply with this code.~~

~~406.8.4.1 Equipment. Appliances and equipment installed in a repair garage shall comply with the provisions of this code, the *Mechanical Code* and the *Electrical Code*.~~

~~406.8.5 Below-grade areas. Pits and below-grade work areas in repair garages shall comply with Sections 406.8.6.1 through 406.8.6.3.~~

~~406.8.5.1 Construction. Pits and below-grade work areas shall be constructed in accordance with this code.~~

~~406.8.5.2 Means of egress. Pits and below-grade work areas shall be provided with means of egress in accordance with Chapter 10.~~

~~406.8.5.3 Ventilation. Where Class I liquids or LP-gas is stored within a building having a basement or pit wherein flammable vapors could accumulate, the basement or pit shall be provided with mechanical ventilation, in accordance with the *Mechanical Code*, at a minimum rate of 1½ cubic feet per minute per~~

~~square foot (cfm/ft²) [0.008 m³/(s × m²)] to prevent the accumulation of flammable vapors.~~

~~406.8.6 Repair garages for vehicles fueled by lighter-than-air fuels. The room, motor vehicle repair booth or motor vehicle repair space containing repair garage activities for the conversion or repair of vehicles that use CNG, LNG, hydrogen or other lighter-than-air motor fuels shall be in accordance with this code. Repair garages for the repair of vehicles that use hydrogen fuel shall be in accordance with this code and NFPA 2.~~

~~Exceptions:~~

- ~~1. Repair garages where work is conducted only on vehicles where the motor vehicle fuel tank and system have been defueled, and the motor vehicle fuel tank has been purged with nitrogen gas.~~
- ~~2. Repair garages where work is not performed on the fuel system and is limited to exchange of parts and maintenance not requiring open flame or welding on the CNG-, LNG-, hydrogen- or other lighter-than-air-fueled motor vehicle. Movement of a subassembly on which the motor vehicle fuel tank remains mounted to allow access to other parts of the vehicle that are not a portion of the fuel system shall be permitted.~~
- ~~3. Repair garages for hydrogen-fueled vehicles where work is not performed on the motor vehicle fuel tank and is limited to the exchange of parts and maintenance not requiring open flame or welding on the hydrogen-fueled vehicle. During the work, the entire hydrogen fuel system shall contain less than 400 cubic feet (11.3 m³) of hydrogen.~~
- ~~4. Repair garages for natural-gas-fueled vehicles where work is not being performed on the motor vehicle fuel tank and is limited to the exchange of parts and maintenance not requiring open flame or welding on the natural-gas-fueled vehicle. During the work, the natural gas in the motor vehicle fuel tank shall contain a pressure of not more than 250 psi at 70°F (1724 kPa at 21°C).~~

~~406.8.6.1 Repair garages used for the repair of hydrogen-fueled vehicles. Repair garages used for the repair of hydrogen-fueled vehicles shall be provided with an approved exhaust ventilation system in accordance with the *Mechanical Code* and Chapter 6 of NFPA 2.~~

~~406.8.6.2 Motor vehicle repair rooms. Motor vehicle repair rooms shall be enclosed with not less than 1-hour fire barriers constructed in accordance with Section 707, or horizontal assemblies constructed in accordance with Section 711, or both, with 1-hour-rated opening protectives.~~

406.8.6.3 Motor vehicle repair booths. The design and construction of motor vehicle repair booths shall be in accordance with Sections 406.8.8.1 through 406.8.8.4.

406.8.6.3.1 Construction. Motor vehicle repair booths shall be constructed of approved noncombustible materials. Where walls or ceiling assemblies are constructed of sheet metal, single-skin assemblies shall be not thinner than 0.0478 inch (18 gage) (1.2 mm) and each sheet of double-skin assemblies shall be not thinner than 0.0359 inch (20 gage) (0.9 mm). Structural sections of motor vehicle repair booths shall be sealed in an approved manner.

406.8.6.3.2 Surfaces. The interior surfaces of motor vehicle repair booths shall be constructed to permit the free passage of exhaust air from all parts of the interior.

406.8.6.3.3 Means of egress. Means of egress shall be provided in accordance with Chapter 10.

Exception: Means of egress doors from premanufactured motor vehicle repair booths shall be not less than 30 inches (762 mm) in width by 80 inches (2032 mm) in height.

406.8.6.3.4 Clear space. Motor vehicle repair booths shall be installed so that all parts of the booth provide ready access for cleaning. A clear area of not less than 3 feet (914 mm) wide shall be provided on all sides of the motor vehicle repair booth.

Exceptions:

1. This requirement shall not prohibit locating a motor vehicle repair booth closer than 3 feet (914 mm) to or directly against an interior partition, wall or floor/ceiling assembly that has a fire-resistance rating of not less than 1 hour, provided that the motor vehicle repair booth can be adequately maintained and cleaned.
2. This requirement shall not prohibit locating a motor vehicle repair booth closer than 3 feet (914 mm) to an exterior wall or a roof assembly, provided that the wall or roof is constructed of noncombustible material and the motor vehicle repair booth can be adequately maintained and cleaned.

406.8.6.4 Motor vehicle repair spaces. Where such spaces are not separately enclosed, noncombustible spray curtains shall be provided to restrict the spread of flammable gases.

406.8.6.5 Fire protection. Motor vehicle repair booths or spaces installed in a room or area protected by an automatic sprinkler system shall have the protection extended to include the inside of the motor vehicle repair booth or space.

406.8.6.6 Exhaust ventilation system. Repair garages used for the repair of CNG, LNG or other lighter-than-air motor fuels other than hydrogen shall be provided with an approved mechanical ventilation system. The mechanical exhaust ventilation system shall be in accordance with the Mechanical Code.

406.8.6.7 ~~406.8.2~~ Gas detection system. Repair garages used for repair of vehicles fueled by nonodorized gases including but not limited to hydrogen and nonodorized LNG, shall be provided with a gas detection system that complies with Section 916. The gas detection system shall be designed to detect leakage of nonodorized gaseous fuel. Where lubrication or chassis service pits are provided in garages used for repairing nonodorized LNG-fueled vehicles, gas sensors shall be provided in such pits.

406.8.6.7.1 ~~406.8.2.1~~ System activation. Activation of a gas detection alarm shall result in all of the following:

1. Initiation of distinct audible and visual alarm signals in the repair garage, where the ventilation system is interlocked with gas detection.
2. Deactivation of all heating systems located in the repair garage.
3. Activation of the mechanical ventilation system, where the system is interlocked with gas detection.

406.8.6.7.2 ~~406.8.2.2~~ Failure of the gas detection system. Failure of the gas detection system shall automatically deactivate the heating system, activate the mechanical ventilation system where the system is interlocked with the gas detection system, and cause a trouble signal to sound at an approved location.

406.8.6.8 Classified electrical area. Areas within 18 inches (450 mm) of a ceiling within a motor vehicle repair room or motor vehicle repair booth shall be designed and installed in accordance with the requirements for Class I, Division 2 classified locations, as set forth in the Electrical Code.

Exceptions:

1. Rooms with exhaust ventilation of not less than 1 cubic foot per minute per square foot (0.3 m³/min/m²) of floor area, with suction taken from a point within 18 inches (450 mm) of the highest point in the ceiling in repair garages for vehicles that use CNG, liquefied natural gas (LNG) or other lighter-than-air motor fuels.
2. Rooms used for the repair of hydrogen-fueled vehicles that have an approved exhaust ventilation system in accordance with the Mechanical Code and Chapter 6 of NFPA 2.

Section 407 Group I-2

- IBC 407.2.7** **407.2.7 Domestic cooking appliances.** In Group I-2 occupancies, installation of cooking appliances used in domestic cooking facilities shall comply with all of the following: *(Items 1 through 5 and the exceptions remain unchanged)*
- ~~6. A portable fire extinguisher shall be provided. Installation shall be in accordance with Section 906, and the extinguisher shall be located within a 30-foot (9144 mm) distance of travel from each domestic cooking appliance.~~
- IBC 407.4** **407.4 Means of egress.** Group I-2 occupancies shall be provided with *means of egress* complying with Chapter 10 and Sections 407.4.1 through 407.4.4. ~~The fire safety and evacuation plans provided in accordance with Section 1002.2 shall identify the building components necessary to support a defend-in-place emergency response in accordance with Sections 403 and 404 of the International Fire Code.~~
- OSSC 407.12** **407.12 Emergency and standby power.** Automatic emergency power and/or standby power supplies shall be provided for all health care facilities, as defined in NFPA 99. The approved alternative power supply shall maintain operating energy to the facility for a period of not less than 90 minutes. Emergency and standby power supplies shall be installed as required in the Electrical Code and in accordance with NFPA 99.

Section 408 Group I-3

- IBC 408.2** **408.2 Other occupancies.** Buildings or portions of buildings in Group I-3 occupancies where security operations necessitate the locking of required *means of egress* shall be permitted to be classified as a different occupancy. Occupancies classified as other than Group I-3 shall meet the applicable requirements of this code for that occupancy where provisions are made for the release of occupants at all times.
- Where security operations necessitate the locking of required *means of egress*, as allowed in Occupancy Conditions 2, 3, 4 and 5, provisions shall be made for the release of occupants at all times.
- Means of egress* from detention and correctional occupancies that traverse other use areas shall, as a minimum, conform to requirements for detention and correctional occupancies.
- Exception:** It is permissible to exit through a *horizontal exit* into other contiguous occupancies that do not conform to detention and correctional occupancy egress provisions but that do comply with requirements set forth in the appropriate occupancy, as long as the occupancy is not a Group H use.
- OSSC 408.3.9** **408.3.9 Cell tier exits.** Exits shall be provided from cell tiers in accordance with Sections 408.3.9.1 through 408.3.9.3.
- 408.3.9.1 Cell tiers above the first level.** Two exits are required from the cell tier above the first level if the occupant load exceeds 10.
- 408.3.9.2 Cell tiers above the second floor.** Two exits are required from cell tiers above the second level.
- 408.3.9.3 Cell tier exit balconies.** Cell tier exit balconies may not have any dead end exceeding 20 feet (6096 mm) in length.
- IBC 408.9** **408.9 Windowless buildings.** *Not adopted*
- 408.9 ~~408.10~~ Fire alarm system.** *Renumbered*
- 408.10 ~~408.11~~ Automatic sprinkler system.** *Renumbered*

- OSSC 408.11 **408.11 Emergency ventilation.** Group I-3 resident housing areas shall be equipped with smoke and heat venting by one of the following:
1. A manually operated mechanical system capable of at not less than six air changes per hour of exhaust with mechanical or natural makeup air.
 2. Roof vents capable of being manually operated, installed in accordance with their listing and Section 910.3.2. The center-to-center spacing between vents shall not be more than 100 feet (45 720 mm) and the venting ratio of effective area of vent openings to floor area shall be 1:150.

Section 412 Aircraft-Related Occupancies

IBC 412.1 **412.1 General.** Aircraft-related occupancies shall comply with Sections 412.1 through 412.7 and the other applicable provisions of this code ~~and the International Fire Code.~~

IBC 412.3.6 **412.3.6 Fire suppression.** Aircraft hangars shall be provided with a fire suppression system designed in accordance with this code and NFPA 409, based on the classification for the hangar given in Table 412.3.6.

Exceptions:

1. Where a *fixed base operator* has separate repair facilities on site, Group II hangars operated by a *fixed base operator* used for storage of *transient aircraft* only shall have a fire suppression system, but the system is exempt from foam requirements.
2. Aircraft hangars that have an aircraft access door height less than 28 feet (8534 mm), and do not have provisions for housing aircraft with a tail height over 28 feet (8534 mm), are exempt from foam requirements, provided that the building complies with all of the following criteria:
 - 2.1. The building is surrounded and adjoined by public ways or yards not less than 60 feet (18 288 mm) in width or shall be provided with *fire-resistance-rated exterior walls* and separation distances in accordance with NFPA 409, Section 5.3.
 - 2.2. The building is provided with an *automatic sprinkler system* throughout with a minimum sprinkler design density of Extra Hazard Group 1.
 - 2.3. The total fuel contained in all aircraft located within a single fire area does not exceed 5,000 gallons (18 927 L).
 - 2.4. No single fire area exceeds 65,000 square feet (3716 m²).
 - 2.5. The gross building area does not exceed 75,000 square feet (4288 m²).

TABLE 412.3.6
HANGAR FIRE SUPPRESSION REQUIREMENTS^{a,b,c}

(Portions of Table 412.3.6 not shown remain unchanged)

- Aircraft hangars with a door height greater than 28 feet shall be provided with fire suppression for a Group I hangar regardless of maximum fire area.
- ~~Groups shall be as classified in accordance with NFPA 409.~~
- ~~e.~~ Membrane structures complying with Section 3102 shall be classified as a Group IV hangar.

IBC 412.5.1 **412.5.1 Occupancy classification.** Aircraft paint hangars shall be classified in accordance with the provisions of Section 307.1. Aircraft paint hangars shall comply with the applicable requirements of this code ~~and the International Fire Code for such occupancy.~~

IBC 412.7.4 **412.7.4 Rooftop heliports and helistops.** Rooftop *heliports* and *helistops* shall comply with Sections 412.7.4.1 and 412.7.4.2, and NFPA 418.

OSSC 412.7.4.1 **412.7.4.1 Standpipe systems.** A building with a rooftop *helistop* or *heliport* shall be provided with a Class I or III standpipe system extended to the roof level on which the *helistop* or *heliport* is located. All portions of the *helistop* and *heliport* area shall be within 150 feet (45 720 mm) of a 2¹/₂-inch (63.5 mm) outlet on the standpipe system.

Section 413 Combustible Storage

IBC 413.1 **413.1 General.** High-piled stock or rack storage in any occupancy group shall comply with [Section 435](#) and the applicable requirements set forth elsewhere in this code ~~the *International Fire Code*~~.

Section 414 Hazardous Materials

IBC 414.1 **414.1 General.** The provisions of Sections 414.1 through 414.18 shall apply to buildings and structures occupied for the manufacturing, processing, dispensing, use or storage of *hazardous materials*. ~~This section shall apply to all hazardous materials, including those materials regulated elsewhere in this code, except where specific requirements are provided in other sections or chapters, those specific requirements shall apply in accordance with the applicable section or chapter. Where a material has multiple hazards, all hazards shall be addressed.~~

~~**414.1.1 Waiver.** The provisions of this chapter are waived where the building official determines that such enforcement is preempted by other codes, statutes or ordinances. The details of any action granting such a waiver shall be recorded and entered in the files of the municipality.~~

[Boilers, pressure vessels and associated piping are regulated by the *Boiler Code* and expressly administered and enforced by the State of Oregon, Building Codes Division, Boiler and Pressure Vessel Code Program. Codes and standards adopted as part of the *Boiler Code* have been excluded from this code.](#)

[Those codes and standards include, but are not limited to, ANSI/ASME B31.1 Power Piping, ANSI/ASME B31.3 Process Piping, ANSI/ASME B31.5 Refrigeration Piping, and ANSI/ASME B31.9 Building Service Piping.](#)

~~**414.1.1.2 414.1.1** Other provisions.~~ (Renumbered)

OSSC 414.1.4 – 414.1.6

~~**414.1.4 Material classification.** *Hazardous materials* are those chemicals or substances defined as such in this code. Definitions of hazardous materials shall apply to all *hazardous materials*, including those materials regulated elsewhere in this code.~~

~~**414.1.4.1 Mixtures.** Mixtures shall be classified in accordance with hazards of the mixture as a whole. Mixtures of *hazardous materials* shall be classified in accordance with nationally recognized reference standards; by an *approved* qualified organization, individual, or Safety Data Sheet (SDS); or by other *approved* methods.~~

~~**414.1.4.2 Hazard categories.** *Hazardous materials* shall be classified according to hazard categories. The categories include materials regulated by this section and materials regulated elsewhere in this code.~~

~~**414.1.4.2.1 Physical hazards.** The material categories listed in this section are classified as *physical hazards*. A material with a primary classification as a *physical hazard* can also pose a *health hazard*.~~

- ~~1. *Explosives* and blasting agents.~~
- ~~2. *Combustible liquids*.~~
- ~~3. *Flammable solids, liquids and gases*.~~
- ~~4. *Organic peroxide solids or liquids*.~~

- ~~5. *Oxidizer, solids or liquids*.~~
- ~~6. *Oxidizing gases*.~~
- ~~7. *Pyrophoric solids, liquids or gases*.~~
- ~~8. *Unstable (reactive) solids, liquids or gases*.~~
- ~~9. *Water-reactive materials, solids or liquids*.~~
- ~~10. *Cryogenic fluids*.~~

~~**414.1.4.2.2 Health hazards.** The material categories listed in this section are classified as *health hazards*. A material with a primary classification as a *health hazard* can also pose a *physical hazard*.~~

- ~~1. *Highly toxic and toxic materials*.~~
- ~~2. *Corrosive materials*.~~

~~**414.1.4.3 Performance-based design alternative.** Where *approved* by the building official, buildings and facilities where *hazardous materials* are stored, used or handled shall be permitted to comply with this section as an alternative to compliance with the other requirements set forth in this chapter and the material-specific provisions elsewhere in this code.~~

~~**414.1.4.3.1 Objective.** The objective of Section 414.1.4.3 is to protect people and property from the consequences of unauthorized discharge, fires or explosions involving *hazardous materials*.~~

414.1.4.3.2 Functional statements. Performance-based design alternatives are based on the following functional statements:

1. Provide safeguards to minimize the risk of unwanted releases, fires or explosions involving *hazardous materials*.
2. Provide safeguards to minimize the consequences of an unsafe condition involving *hazardous materials* during normal operations and in the event of an abnormal condition.

414.1.4.3.3 Performance requirements. Where safeguards, systems, documentation, written plans or procedures, audits, process hazards analysis, mitigation measures, engineering controls or construction features are required by Sections 414.1.4.3.3.1 through 414.1.4.3.3.11, the details of the design alternative shall be subject to approval by the *building official*. The details of actions granting the use of the design alternatives shall be recorded and entered in the files of the jurisdiction.

414.1.4.3.3.1 Properties of hazardous materials. The physical- and health-hazard properties of *hazardous materials* on-site shall be known and shall be made readily available to employees, neighbors and the *building official*.

414.1.4.3.3.2 Reliability of equipment and operations. Equipment and operations involving *hazardous materials* shall be designed, installed and maintained to ensure that they reliably operate as intended.

414.1.4.3.3.3 Prevention of unintentional reaction or release. Safeguards shall be provided to minimize the risk of an unintentional reaction or release that could endanger people or property.

414.1.4.3.3.4 Spill mitigation. Spill *containment systems* or means to render a spill harmless to people or property shall be provided where a spill is determined to be a plausible event and where such an event would endanger people or property.

414.1.4.3.3.5 Ignition hazards. Safeguards shall be provided to minimize the risk of exposing combustible *hazardous materials* to unintended sources of ignition.

414.1.4.3.3.6 Protection of hazardous materials. Safeguards shall be provided to minimize the risk of exposing *hazardous materials* to a fire or physical damage whereby such exposure could endanger or lead to the endangerment of people or property.

414.1.4.3.3.7 Exposure hazards. Safeguards shall be provided to minimize the risk of and limit damage from a fire or explosion involving explosive *hazardous materials* whereby such fire or explosion could endanger or lead to the endangerment of people or property.

414.1.4.3.3.8 Detection of gas or vapor release. Where a release of hazardous materials gas or vapor would cause immediate harm to persons or property, means of mitigating the dangerous effects of a release shall be provided.

414.1.4.3.3.9 Reliable power source. Where a power supply is relied on to prevent or control an emergency condition that could endanger people or property, the power supply shall be from a reliable source.

414.1.4.3.3.10 Ventilation. Where ventilation is necessary to limit the risk of creating an emergency condition resulting from normal or abnormal operations, means of ventilation shall be provided.

414.1.4.3.3.11 Process hazard analyses. Process hazard analyses shall be conducted to reasonably ensure the protection of people and property from dangerous conditions involving *hazardous materials*.

414.1.5 Hazardous Materials Inventory Statement (HMIS). Where required by the *building official*, an application for a permit shall include an HMIS, such as Superfund Amendments and Reauthorization Act of 1986 (SARA) Title III, Tier II Report or other approved statement. The HMIS shall include the following information:

1. Product name.
2. Component.
3. Chemical Abstract Service (CAS) number.
4. Location where stored or used.
5. Container size.
6. Hazard classification.
7. Amount in storage.
8. Amount in use-closed systems.
9. Amount in use-open systems.

414.1.6 Maximum allowable quantity per control area. The *maximum allowable quantity per control area* shall be as specified in Tables 307.1(1) and 307.1(2).

For retail and wholesale storage and display in Group M occupancies and Group S storage areas, see Section 414.2.5.

414.1.6.1 Conversion. Where quantities are indicated in pounds and where the weight per gallon of the liquid is not provided to the *building official*, a conversion factor of 10 pounds per gallon (1.2 kg/L) shall be used.

IBC 414.2 **414.2 Control areas.** *Control areas* shall comply with Sections 414.2.1 through 414.2.5 and the applicable requirements set forth elsewhere in this code ~~and the *International Fire Code*.~~

Exception: *Higher education laboratories* in accordance with Section 428 ~~and Chapter 38 of the *International Fire Code*.~~

IBC 414.2.5 **414.2.5.1 Nonflammable solids and nonflammable and noncombustible liquids.** The aggregate quantity of nonflammable solid and nonflammable or noncombustible liquid hazardous materials permitted within a single *control area* of a Group M display and storage area, a Group S storage area ~~or an outdoor control area~~ is permitted to exceed the maximum allowable quantities per *control area* specified in Tables 307.1(1) and 307.1(2) without classifying the building or use as a Group H occupancy, provided that the materials are displayed and stored in accordance with this code ~~the *International Fire Code*~~ and quantities do not exceed the maximum allowable specified in Table 414.2.5(1).

414.2.5.1.1 Storage and display. Storage and display shall be in accordance with Sections 414.2.5.1.1.1 through 414.2.5.1.1.11.

414.2.5.1.1.1 Density. Storage and display of solids shall not exceed 200 pounds per square foot (976 kg/m²) of floor area actually occupied by solid merchandise. Storage and display of liquids shall not exceed 20 gallons per square foot (0.50 L/m²) of floor area actually occupied by liquid merchandise.

414.2.5.1.1.2 Storage and display height. Display height shall not exceed 6 feet (1829 mm) above the finished floor in display areas of Group M occupancies. Storage height shall not exceed 8 feet (2438 mm) above the finished floor in storage areas of Group M and Group S occupancies.

414.2.5.1.1.3 Container location. Individual *containers* less than 5 gallons (19 L) or less than 25 pounds (11 kg) shall be stored or displayed on pallets, racks or shelves.

414.2.5.1.1.4 Racks and shelves. Racks and shelves used for storage or display shall be in accordance with Section 414.17.

414.2.5.1.1.5 Container type. *Containers* shall be *approved* for the intended use and identified as to their content.

414.2.5.1.1.6 Container size. Individual *containers* shall not exceed 100 pounds (45 kg) for solids or 10 gallons (38 L) for liquids in storage and display areas.

414.2.5.1.1.7 Incompatible materials. *Incompatible materials* shall be separated in accordance with Section 414.19.

414.2.5.1.1.8 Floors. Floors shall be in accordance with Section 415.12.8.

414.2.5.1.1.9 Aisles. Aisles 4 feet (1219 mm) in width shall be maintained on three sides of the storage or display area.

414.2.5.1.1.10 Signs. Hazard identification signs shall be provided in accordance with Section 414.8.

414.2.5.1.1.11 Storage plan. A storage plan illustrating the intended storage arrangement, including the location and dimensions of aisles and storage racks shall be provided.

TABLE 414.2.5(1)
MAXIMUM ALLOWABLE QUANTITY PER INDOOR ~~AND OUTDOOR~~ CONTROL AREA IN GROUP M AND S OCCUPANCIES
OF NONFLAMMABLE SOLIDS AND NONFLAMMABLE AND NONCOMBUSTIBLE LIQUIDS^{d,e,f}

(Portions of the table not shown remain unchanged)

Material ^a	CONDITION		MAXIMUM ALLOWABLE QUANTITY PER CONTROL AREA	
	Class		Solids (pounds)	Liquids (gallons)
A. Health-hazard materials—nonflammable and noncombustible solids and liquids				
3. Toxics ^{b,c}	Not Applicable		1,000 ^{h,i}	100
B. Physical-hazard materials—nonflammable and noncombustible solids and liquids				
1. Oxidizers ^{b,c}	4		Not Allowed	Not Allowed
	3		1,350 ^{g,f}	115
	2		2,250 ^{h,g}	225
	1		18,000 ^{i,j,h}	1,800 ^{i,j,h}

- ~~f.~~ Maximum quantities shall be increased 100 percent in outdoor control areas.
- ~~f. g.~~ Maximum amounts shall be increased to 2,250 pounds where individual packages are in the original sealed containers from the manufacturer or packager and do not exceed 10 pounds each.
- ~~g. h.~~ Maximum amounts shall be increased to 4,500 pounds where individual packages are in the original sealed containers from the manufacturer or packager and do not exceed 10 pounds each.
- ~~h. i.~~ The permitted quantities shall not be limited in a building equipped throughout with an automatic sprinkler system in accordance with Section 903.3.1.1.
- ~~j.~~ Quantities are unlimited in an outdoor control area.
- ~~i. k.~~ Maximum allowable quantities of consumer products shall be increased to 10,000 pounds where individual packages are in the original, sealed containers from the manufacturer and the toxic classification is exclusively based on the LC threshold and no other hazardous materials classifications apply.

TABLE 414.2.5(2)
MAXIMUM ALLOWABLE QUANTITY OF FLAMMABLE AND COMBUSTIBLE LIQUIDS IN WHOLESALE AND RETAIL SALES
OCCUPANCIES PER CONTROL AREA^a

(Portions of the table not shown remain unchanged)

TYPE OF LIQUID	MAXIMUM ALLOWABLE QUANTITY PER CONTROL AREA (gallons)		
	Sprinklered in accordance with Note b densities and arrangements	Sprinklered in accordance with Tables 444.4.7.3(4) through 444.4.7.3(8) and 444.4.8.5.2 Tables 5704.3.6.3(4) through 5704.3.6.3(8) and 5704.3.7.5.1 of the International Fire Code	Nonsprinklered

TABLE 414.5.1
EXPLOSION CONTROL REQUIREMENTS^{a,h,g}

(Portions of the table not shown remain unchanged)

MATERIAL	CLASS	EXPLOSION CONTROL METHODS	
		Barricade construction	Explosion (deflagration) venting or explosion (deflagration) prevention systems ^b
HAZARD CATEGORY			
Combustible dusts ^{b,h}	—	Not Required	Required
Flammable liquid	IA ^{d,c}	Not Required	Required
	IB ^d	Not Required	Required
Water-reactive liquids and solids	3	Not Required	Required
	2 ^{g,f}	Not Required	Required
SPECIAL USES			
Electrochemical energy storage system ^h	—	Not Required	Required
Energy storage system ^h	—	Not Required	Required
Where explosion hazards exist ^{d,c}	Detonation	Required	Not Permitted
	Deflagration	Not Required	Required

- a. See Section 414.1.3.
- ~~b.~~ See the [International Fire Code](#).
- b. Combustible dusts where manufactured, generated or used in such a manner that the concentration and conditions create a fire or explosion hazard based on information prepared in accordance [with this code](#) ~~with Section 104.8.2 of the International Fire Code~~. See definition of "Combustible dust" in Chapter 2.
- c. Storage or use.
- d. In open use or dispensing.
- e. Rooms containing dispensing and use of hazardous materials where an explosive environment can occur because of the characteristics or nature of the hazardous materials or as a result of the dispensing or use process.
- f. A method of explosion control shall be provided where Class 2 water-reactive materials can form potentially explosive mixtures.
- g. Explosion venting is not required for Group H-5 fabrication areas complying with Section 415.11.1 ~~and the International Fire Code~~.
- h. Where explosion control is required in [Section 414.5.1](#) ~~Section 1207 of the International Fire Code~~.

IBC 414.6 **414.6 Outdoor storage, dispensing and use.** The [weather protection of](#) outdoor storage, dispensing and use of *hazardous materials* shall be in accordance with [this code](#) ~~the *International Fire Code*~~.

OSSC 414.7 – 414.21

414.7 Systems, equipment and processes. Systems, equipment and processes utilized for storage, dispensing, use or handling of *hazardous materials* shall be in accordance with Sections 414.7.1 through 414.7.5.

414.7.1 Equipment, machinery and alarms. Equipment, machinery and required detection and alarm systems associated with the use, storage or handling of *hazardous materials* shall be listed or approved.

414.7.2 Installation of tanks. Installation of tanks shall be in accordance with Section 414.7.2.1 and this code.

414.7.2.1 Marking. Above-ground stationary tanks shall be marked as required by Section 414.8.

414.7.3 Liquid-level limit control. Atmospheric tanks having a capacity greater than 500 gallons (1893 L) and containing hazardous material liquids shall be equipped with a liquid-level limit control or other approved means to prevent overfilling of the tank.

414.7.4 Seismic protection. Machinery and equipment utilizing *hazardous materials* shall be braced and anchored in accordance with the seismic design requirements of this code for the seismic design category in which the machinery or equipment is classified.

414.7.5 Testing. The equipment, devices and systems listed in Section 414.7.5.1 shall be tested at the time of installation

414.7.5.1 Equipment, devices and systems requiring testing. The following equipment, systems and devices shall be tested in accordance with Section 414.7.5.

1. Gas detection systems, alarms and *automatic emergency shutoff valves* required by Section 447 for highly toxic and toxic gases.
2. Limit control systems for liquid level, temperature and pressure required by Sections 414.7.3, 415.12.7 and 415.13.4.
3. Emergency alarm systems and supervision required by this code.
4. Monitoring and supervisory systems required by this code.
5. *Manually activated shutdown controls* required by Section 451 for *compressed gas systems* conveying pyrophoric gases.

414.8 Hazard identification signs. Unless otherwise exempted by the *building official*, visible hazard identification signs as specified in NFPA 704 for the specific material contained shall be placed on stationary *containers* and aboveground tanks and at entrances to locations where *hazardous materials* are stored, dispensed, used or handled in quantities requiring a permit and at specific entrances and locations designated by the *building official*.

414.8.1 Markings. Individual *containers, cartons* or packages shall be conspicuously marked or labeled in an approved manner. Rooms or cabinets containing *compressed gases* shall be conspicuously labeled: COMPRESSED GAS.

414.9 Signs. Signs and markings required by Sections 414.8 and 414.8.1 shall not be obscured or removed; shall be in English as a primary language or in symbols allowed by this code; shall be durable; and the size, color and lettering shall be approved.

414.10 Sources of ignition. Sources of ignition shall comply with Section 414.10.1.

414.10.1 Smoking. Smoking shall be prohibited and “No Smoking” signs provided as follows:

1. In rooms or areas where *hazardous materials* are stored or dispensed or used in *open systems*.
2. Facilities or areas within facilities that have been designated as totally “no smoking” shall have “No Smoking” signs placed at all entrances to the facility or area. Designated areas within such facilities where smoking is permitted, either permanently or temporarily, shall be identified with signs designating that smoking is permitted in these areas only.
3. In rooms or areas where flammable or combustible *hazardous materials* are stored, dispensed or used.

Signs required by this section shall be in English as a primary language or in symbols allowed by this code.

414.10.2 Respiratory therapy. In Group I-2 and ambulatory care facilities, within areas with respiratory therapy services, sources of ignition shall be regulated in accordance with NFPA 99.

414.11 Gas rooms. Where a gas room is used to increase the *maximum allowable quantity per control area* or is provided to comply with the provisions of Section 447, the gas room shall be in accordance with Sections 414.11.1 and 414.11.2.

414.11.1 Construction. Gas rooms shall be protected with an *automatic sprinkler system*. Gas rooms shall be separated from the remainder of the building in accordance with the requirements of this code based on the occupancy group into which it has been classified.

414.11.2 Ventilation system. The ventilation system for gas rooms shall be designed to operate at a negative pressure in relation to the surrounding area. Highly toxic and toxic gases shall also comply with Section 447. The ventilation system shall be installed in accordance with the *Mechanical Code*.

414.12 Exhausted enclosures. Where an exhausted enclosure is used to increase *maximum allowable quantity per control area* or where the location of *hazardous materials* in exhausted enclosures is provided to comply with the provisions of Section 447, the exhausted enclosure shall be in accordance with Sections 414.12.1 through 414.12.3.

414.12.1 Construction. Exhausted enclosures shall be of noncombustible construction.

414.12.2 Ventilation. Exhausted enclosures shall be provided with an exhaust ventilation system. The ventilation system for exhausted enclosures shall be designed to operate at a negative pressure in relation to the surrounding area. Ventilation systems used for highly toxic and toxic gases shall also comply with Items 1, 2 and 3 of Section 447.3.3. The ventilation system shall be installed in accordance with the *Mechanical Code*.

414.12.3 Fire-extinguishing system. Exhausted enclosures where flammable materials are used shall be protected by an *approved* automatic fire-extinguishing system in accordance with Chapter 9.

414.13 Gas cabinets. Where a gas cabinet is used to increase the *maximum allowable quantity per control area* or where the location of *compressed gases* in *gas cabinets* is provided to comply with the provisions of Section 447, the gas cabinet shall be in accordance with Sections 414.13.1 through 414.13.3.

414.13.1 Construction. Gas cabinets shall be constructed with the following:

1. Not less than 0.097-inch (2.5 mm) (No. 12 gage) steel.
2. Self-closing limited access ports or noncombustible windows to give access to equipment controls.
3. Self-closing doors.
4. Interiors treated, coated or constructed of materials that are compatible with the *hazardous materials* stored. Such treatment, coating or construction shall include the entire interior of the cabinet.

414.13.2 Ventilation. Gas cabinets shall be provided with an exhaust ventilation system. The ventilation system for gas cabinets shall be designed to operate at a negative pressure in relation to the surrounding area. Ventilation systems used for highly toxic and toxic gases shall also comply with Items 1, 2 and 3 of Section 447.3.2. The ventilation system shall be installed in accordance with the *Mechanical Code*.

414.13.3 Maximum number of cylinders per gas cabinet. The number of *cylinders* contained in a single gas cabinet shall not exceed three.

414.14 Hazardous materials storage cabinets. Where storage cabinets are used to increase *maximum allowable quantity per control area* or to comply with this chapter, such cabinets shall be in accordance with Sections 414.14.1 and 414.14.2.

414.14.1 Construction. The interior of cabinets shall be treated, coated or constructed of materials that are nonreactive with the *hazardous materials* stored. Such treatment, coating or construction shall include the entire interior of the cabinet. Cabinets shall either be *listed* in accordance with UL 1275 as suitable for the intended storage or constructed in accordance with the following:

1. Cabinets shall be of steel having a thickness of not less than 0.0478 inch (1.2 mm) (No. 18 gage). The cabinet, including the door, shall be double walled with a 1/2-inch (38 mm) airspace between the walls. Joints shall be riveted or welded and shall be tight fitting. Doors shall be well fitted, self-closing and equipped with a self-latching device.
2. The bottoms of cabinets utilized for the storage of liquids shall be liquid tight to a minimum height of 2 inches (51 mm).

414.14.2 Warning markings. Cabinets shall be clearly identified in an *approved* manner with red letters on a contrasting background to read: HAZARDOUS—KEEP FIRE AWAY.

414.15 Protection from vehicles. Guard posts or other *approved* means shall be provided to protect storage tanks and connected piping, valves and fittings; dispensing areas; and use areas subject to vehicular damage in accordance with Section 912.4.4.

414.16 Electrical wiring and equipment. Electrical wiring and equipment shall be installed and maintained in accordance with *Electrical Code*.

414.17 Static accumulation. Where processes or conditions exist where a flammable mixture could be ignited by static electricity, means shall be provided to prevent the accumulation of a static charge.

414.18 Shock padding. Materials that are shock sensitive shall be padded, suspended or otherwise protected against accidental dislodgement and dislodgement during seismic activity.

414.19 Separation of incompatible materials. *Incompatible materials* in storage and storage of materials that are incompatible with materials in use shall be separated where the stored materials are in *containers* having a capacity of more than 5 pounds (2 kg), 0.5 gallon (2 L) or any amount of *compressed gases*. Separation shall be accomplished by:

1. *Segregating incompatible materials in storage by a distance of not less than 20 feet (6096 mm).*
2. *Isolating incompatible materials in storage by a noncombustible partition extending not less than 18 inches (457 mm) above and to the sides of the stored material.*
3. *Storing liquid and solid materials in hazardous materials storage cabinets.*
4. *Storing compressed gases in gas cabinets or exhausted enclosures in accordance with Sections 414.12 and 414.13.*

Materials that are incompatible shall not be stored within the same cabinet or exhausted enclosure.

414.20 Shelf storage. Shelving shall be of substantial construction and shall be braced and anchored in accordance with the seismic design requirements of this code for the seismic zone in which the material is located. Shelving shall be treated, coated or constructed of materials that are compatible with the *hazardous materials* stored. Shelves shall be provided with a lip or guard where used for the storage of individual *containers*.

Exception: Storage in *hazardous materials* storage cabinets or laboratory furniture specifically designed for such use.

414.21 Safety cans. *Safety cans* shall be listed in accordance with UL 30 where used to increase the *maximum allowable quantities per control area* of flammable or *combustible liquids* in accordance with this code. *Safety cans* listed in accordance with UL 1313 are allowed for flammable and *combustible liquids* where not used to increase the *maximum allowable quantities per control area* and for other hazardous material liquids in accordance with the listing.

Section 415 Groups H-1, H-2, H-3, H-4 and H-5

OSSC 415.4.1 **415.4.1 Automatic sprinkler systems.** Indoor storage areas and storage buildings shall be equipped throughout with an *approved automatic sprinkler system* in accordance with Section 903.3.1.1. The design of the sprinkler system shall be not less than that required for Ordinary Hazard Group 2 with a minimum design area of 3,000 square feet (279 m²). Where the materials or storage arrangement is required by other regulations to be provided with a higher level of sprinkler system protection, the higher level of sprinkler system protection shall be provided.

415.4.2 Fire-extinguishing systems. Indoor rooms or areas in which *hazardous materials* are dispensed or used shall be protected by an automatic fire-extinguishing system in accordance with Chapter 9. Sprinkler system design shall be not less than that required for Ordinary Hazard Group 2, with a minimum design area of 3,000 square feet (279 m²). Where the materials or storage arrangement are required by other regulations to be provided with a higher level of sprinkler system protection, the higher level of sprinkler system protection shall be provided.

IBC 415.9 **415.9 Group H-2.** In addition to the requirements set forth elsewhere in this code, occupancies in Group H-2 shall be constructed in accordance with Sections 415.9.1 through 415.9.3 ~~and the International Fire Code.~~

415.9.1 Flammable and combustible liquids. In addition to the requirements set forth elsewhere in this code, the storage, handling, processing and transporting of flammable and combustible liquids in Group H-2 and H-3 occupancies shall be in accordance with Sections 415.9.1.1 through 415.9.1.9, ~~and the International Mechanical Code and the International Fire Code.~~

IBC 415.11.1.1 **415.11.1.1 Hazardous materials.** Hazardous materials and hazardous production materials (HPM) shall comply with Sections 415.11.1.1.1 and 415.11.1.1.2. ~~Where a material poses multiple hazards, all hazards shall be addressed.~~

IBC 415.11.1.7 **415.11.1.7 Transporting hazardous production materials to fabrication areas.** HPM shall be transported to *fabrication areas* through enclosed piping or tubing systems ~~in accordance with the Boiler Code, that comply with Section 415.11.7,~~ through *service corridors* complying with Section 415.11.3, or in *corridors* as permitted in the exception to Section 415.11.2. The handling or transporting of HPM within *service corridors* shall comply with ~~this code the International Fire Code.~~

OSSC 415.11.1.9 - 415.11.1.13.5

415.11.1.9 Gas cabinets. Gas cabinets shall comply with Section 414.13.

415.11.1.10 Exhausted enclosures. Exhausted enclosures shall comply with Section 414.12.

415.11.1.11 Gas rooms. Gas rooms shall comply with Section 414.11.

415.11.1.12 Cabinets containing pyrophoric liquids or water-reactive Class 3 liquids. Cabinets in fabrication areas containing pyrophoric liquids or Class 3 water-reactive liquids in containers or in amounts greater than $\frac{1}{2}$ gallon (2 L) shall comply with Section 415.11.6.5.

415.11.1.13 Automatic sprinkler system. An approved automatic sprinkler system shall be provided in accordance with Sections 415.11.1.13.1 through 415.11.1.13.5 and Chapter 9.

415.11.1.13.1 Workstations and tools. The design of the sprinkler system in the area shall take into consideration the spray pattern and the effect on the equipment.

415.11.1.13.1.1 Combustible workstations. A sprinkler head shall be installed within each branch exhaust connection or individual plenums of workstations of combustible construction. The sprinkler head in the exhaust connection or plenum shall be located not more than 2 feet (610 mm) from the point of the duct connection or the connection to the plenum. Where necessary to prevent corrosion, the sprinkler head and connecting piping in the duct shall be coated with approved or listed corrosion-resistant materials. Access to the sprinkler head shall be provided for periodic inspection.

Exceptions:

1. Approved alternative automatic fire-extinguishing systems are allowed. Activation of such systems shall deactivate the related processing equipment.
2. Process equipment that operates at temperatures exceeding 932°F (500°C) and is provided with automatic shutdown capabilities for hazardous materials.
3. Exhaust ducts 10 inches (254 mm) or less in diameter from flammable gas storage cabinets that are part of a workstation.
4. Ducts listed or approved for use without internal automatic sprinkler protection.

415.11.1.13.1.2 Combustible tools. Where the horizontal surface of a combustible tool is obstructed from ceiling sprinkler discharge, automatic sprinkler protection that covers the horizontal surface of the tool shall be provided.

Exceptions:

1. An automatic gaseous fire-extinguishing local surface application system shall be allowed as an alternative to sprinklers. Gaseous-extinguishing systems shall be actuated by infrared (IR) or ultraviolet/ infrared (UV/IR) optical detectors.
2. Tools constructed of materials that are listed as Class 1 or Class 2 in accordance with UL 2360 or approved for use without internal fire-extinguishing system protection.

415.11.1.13.2 Gas cabinets and exhausted enclosures. An approved automatic sprinkler system shall be provided in gas cabinets and exhausted enclosures containing HPM compressed gases.

Exception: Gas cabinets located in an HPM room other than those cabinets containing pyrophoric gases.

415.11.1.13.3 Exhaust connections and plenums of combustible workstations. Automatic fire-extinguishing system protection for exhaust connections and plenums of combustible workstations shall comply with Section 415.11.1.13.1.1.

415.11.1.13.4 Exhaust duct sprinkler system requirements. Automatic sprinklers installed in exhaust duct systems shall be hydraulically designed to provide 0.5 gallons per minute (gpm) (1.9 L/min) over an area derived by multiplying the distance between the sprinklers in a horizontal duct by the width of the duct. Minimum discharge shall be 20 gpm (76 L/min) per sprinkler from the five hydraulically most remote sprinklers.

415.11.1.13.4.1 Control valve. A separate indicating control valve shall be provided for sprinklers installed in exhaust ducts.

415.11.1.13.4.2 Drainage. Drainage shall be provided to remove sprinkler water discharged in exhaust ducts.

415.11.1.13.4.3 Corrosive atmospheres. Where corrosive atmospheres exist, exhaust duct sprinklers and pipe fittings shall be manufactured of corrosion-resistant materials or coated with approved materials.

415.11.1.13.5 Sprinkler alarms and supervision. Automatic sprinkler systems shall be electrically supervised and provided with alarms in accordance with Chapter 9. Automatic sprinkler system alarm and supervisory signals shall be transmitted to the emergency control station.

IBC 415.11.2 **415.11.2 Corridors.** *Corridors shall comply with Chapter 10 and shall be separated from fabrication areas as specified in Section 415.11.1.2. Corridors shall not contain HPM and shall not be used for transporting such materials except through closed piping systems in accordance with the Boiler Code as provided in Section 415.11.7.4. (The exceptions remain unchanged)*

OSSC 415.11.7

415.11.7 Workstations. *Workstations in fabrication areas shall be in accordance with Sections 415.11.7.1 through 415.11.7.5.*

415.11.7.1 Construction. *Workstations in fabrication areas shall be constructed of materials compatible with the materials used and stored at the workstation. The portion of the workstation that serves as a cabinet for HPM gases, Class I flammable liquids, or Class II or Class IIIA combustible liquids shall be noncombustible and, if of metal, shall be not less than 0.0478-inch (18 gage) (1.2 mm) steel.*

415.11.7.2 Maximum aggregate quantities at workstations. *The quantity of HPM in use at a workstation shall not exceed the quantities listed in Table 415.11.7.2.*

415.11.7.3 Protection of vessels. *Vessels containing hazardous materials located in or connected to a workstation shall be protected as follows:*

1. *HPM: Vessels containing HPM shall be protected from physical damage and shall not project from the workstation.*
2. *Hazardous cryogenic fluids, gases and liquids: Hazardous cryogenic fluid, gas and liquid vessels located within a workstation shall be protected from seismic forces in an approved manner in accordance with this code.*

415.11.7.4 Drainage and containment for HPM liquids. *Each workstation utilizing HPM liquids shall have all of the following:*

1. *Drainage piping systems connected to a compatible system for disposition of such liquids.*
2. *The work surface provided with a slope or other means for directing spilled materials to the containment or drainage system.*
3. *An approved means of containing or directing spilled or leaked liquids to the drainage system.*

415.11.7.5 Pyrophoric solids, liquids and Class 3 water-reactive liquids. *Pyrophoric liquids and Class 3 water-reactive liquids in containers greater than 0.5 gallon (2 L) but not exceeding 5.3-gallon (20 L) capacity and pyrophoric solids in containers greater than 4.4 pounds (2 kg) but not exceeding 44 pounds (20 kg) shall be allowed at workstations where located inside cabinets and the following conditions are met:*

1. *Maximum amount per cabinet: The maximum amount per cabinet shall be limited to 5.3 gallons (20 L) of liquids and 44 pounds (20 kg) of total liquids and solids.*
2. *Cabinet construction: Cabinets shall be constructed in accordance with the following:*

2.1. *Cabinets shall be constructed of not less than 0.097-inch (2.5 mm) (12 gage) steel.*

2.2. *Cabinets shall be permitted to have self-closing limited access ports or noncombustible windows that provide access to equipment controls.*

2.3. *Cabinets shall be provided with self- or manual-closing doors. Manual-closing doors shall be equipped with a door switch that will initiate local audible and visual alarms when the door is in the open position.*

3. *Cabinet exhaust ventilation system: An exhaust ventilation system shall be provided for cabinets and shall comply with the following:*

3.1. *The system shall be designed to operate at a negative pressure in relation to the surrounding area.*

3.2. *The system shall be equipped with monitoring equipment to ensure that required exhaust flow or static pressure is provided.*

3.3. *Low-flow or static pressure conditions shall send an alarm to the on-site emergency control station. The alarm shall be both visual and audible.*

4. *Cabinet spill containment: Spill containment shall be provided in each cabinet, with the spill containment capable of holding the contents of the aggregate amount of liquids in containers in each cabinet.*

5. *Valves: Valves in supply piping between the product containers in the cabinet and the workstation served by the containers shall fail in the closed position upon power failure, loss of exhaust ventilation and actuation of the fire control system.*

6. *Fire detection system: Each cabinet shall be equipped with an automatic fire detection system complying with the following conditions:*

6.1. *Automatic detection system: UV/IR, high-sensitivity smoke detection (HSSD) or other approved detection systems shall be provided inside each cabinet.*

6.2. *Automatic shutoff: Activation of the detection system shall automatically close the shutoff valves at the source on the liquid supply.*

6.3. *Alarms and signals: Activation of the detection system shall initiate a local alarm within the fabrication area and transmit a signal to the emergency control station. The alarms and signals shall be both visual and audible.*

**TABLE 415.11.7.2
MAXIMUM QUANTITIES OF HPM AT A WORKSTATION^d**

HPM CLASSIFICATION	STATE	MAXIMUM QUANTITY
Corrosive	Gas	Combined aggregate volume of all cylinders at a workstation shall not exceed an internal cylinder volume of 39.6 gallons or 5.29 cubic feet
	Liquid	Use-open system: 25 gallons ^b ; Use-closed system: 150 gallons ^{b, e}
	Solid	20 pounds ^{a, b}
Flammable, highly toxic, pyrophoric and toxic combined	Gas	Combined aggregate volume of all cylinders at a workstation shall not exceed an internal cylinder volume of 39.6 gallons or 5.29 cubic feet
Flammable	Liquid	15 gallons ^{a, b}
	Solid	5 pounds ^{a, b}
Highly toxic	Liquid	15 gallons ^a
	Solid	5 pounds ^a
Oxidizer	Gas	Combined aggregate volume of all cylinders at a workstation shall not exceed an internal cylinder volume of 39.6 gallons or 5.29 cubic feet
	Liquid	Use-open system: 12 gallons ^b ; Use-closed system: 60 gallons ^b
	Solid	20 pounds ^{a, b}
Pyrophoric	Liquid	0.5 gallon ^{e, f}
	Solid	4.4 pounds ^{e, f}
Toxic	Liquid	Use-open system: 15 gallons ^b ; Use-closed system: 60 gallons ^b
	Solid	5 pounds ^{a, b}
Unstable reactive Class 3	Liquid	0.5 gallon ^{a, b}
	Solid	5 pounds ^{a, b}
Water-reactive Class 3	Liquid	0.5 gallon ^{e, f}
	Solid	See Table 415.11.1.1.1

For SI: 1 pound = 0.454 kg, 1 gallon = 3.785 L.

- a. . . Maximum allowable quantities shall be increased 100 percent for closed system operations. Where Note b applies, the increase for both notes shall be allowed.
- b. . . Quantities shall be allowed to be increased 100 percent where workstations are internally protected with an approved automatic fire-extinguishing or suppression system complying with Chapter 9. Where Note a applies, the increase for both notes shall be allowed. Where Note e applies, the maximum increase allowed for both Notes b and e shall not exceed 100 percent.
- c. . . Allowed only in workstations that are internally protected with an approved automatic fire-extinguishing or fire protection system complying with Chapter 9 and compatible with the reactivity of materials in use at the workstation.
- d. . . The quantity limits apply only to materials classified as HPM.
- e. . . Quantities shall be allowed to be increased 100 percent for nonflammable, noncombustible corrosive liquids where the materials of construction for workstations are listed or approved for use without internal fire-extinguishing or suppression system protection. Where Note b applies, the maximum increase allowed for both Notes b and e shall not exceed 100 percent.
- f. . . A maximum quantity of 5.3 gallons of liquids and 44 pounds of total liquids and solids shall be allowed at a workstation where conditions are in accordance with Section 415.11.6.5.

IBC 415.11.7 415.11.7 Piping and tubing. *Not adopted*
415.11.7.1 HPM having a health-hazard ranking of 3 or 4. *Not adopted*
415.11.7.2 Location in service corridors. *Not adopted*
415.11.7.3 Excess flow control. *Not adopted*
415.11.7.4 Installations in corridors and above other occupancies. *Not adopted*
415.11.7.5 Identification. *Not adopted*

OSSC 415.11.10.4 [415.11.10.4 Increased travel distance.](#) Where travel distance is increased in accordance with Section 1017.2.3, the use of smoke detection systems for automatic shutoff of return air systems is not required where analysis demonstrates shutoff would create a greater hazard. A smoke detection system with remote indication and manual shutoff capability at the emergency control station shall be required.

OSSC 415.11.13 [415.11.13 Treatment systems.](#) Treatment systems for highly toxic and toxic gases shall comply with Section 447.

OSSC 415.11.14 [415.11.14 Sub-atmospheric pressure gas systems.](#) Subatmospheric pressure gas systems (SAGS) shall be in accordance with NFPA 318.

OSSC 415.12 – 415.13.3

415.12 Hazardous materials storage. Storage of hazardous materials in amounts exceeding the maximum allowable quantity per control area shall be in accordance with Sections 414 and 415.12.1 through 415.12.2.5.

415.12.1 Spill control and secondary containment for liquid and solid hazardous materials. Rooms, buildings or areas used for the storage of liquid or solid hazardous materials shall be provided with spill control and secondary containment in accordance with Sections 415.12.1.1 through 415.12.2.3.

415.12.1.1 Spill control for hazardous material liquids. Rooms, buildings or areas used for the storage of hazardous material liquids in individual vessels having a capacity of more than 55 gallons (208 L), or in which the aggregate capacity of multiple vessels exceeds 1,000 gallons (3785 L), shall be provided with spill control to prevent the flow of liquids to adjoining areas. Floors in indoor locations shall be constructed to contain a spill from the largest single vessel by one of the following methods:

1. ... Liquid-tight sloped or recessed floors in indoor locations.
2. ... Liquid-tight floors in indoor locations with liquid-tight raised or recessed sills or dikes.
3. ... Sumps and collection systems.
4. ... Other approved engineered systems.

Except for surfacing, the floors, sills, dikes, sumps and collection systems shall be constructed of noncombustible material, and the liquid-tight seal shall be compatible with the material stored. Where liquid-tight sills or dikes are provided, they are not required at perimeter openings having an open-grate trench across the opening that connects to an approved collection system.

415.12.2 Secondary containment for hazardous material liquids and solids. Where required by Table 415.12.2, buildings, rooms or areas used for the storage of hazardous material liquids or solids shall be provided with secondary containment in accordance with this section where the capacity of an individual vessel or the aggregate capacity of multiple vessels exceeds both of the following:

1. Liquids: Capacity of an individual vessel exceeds 55 gallons (208 L) or the aggregate capacity of multiple vessels exceeds 1,000 gallons (3785 L).
2. Solids: Capacity of an individual vessel exceeds 550 pounds (250 kg) or the aggregate capacity of multiple vessels exceeds 10,000 pounds (4540 kg).

415.12.2.1 Containment and drainage methods. The building, room or area shall contain or drain the hazardous materials and fire protection water through the use of one of the following methods:

1. ... Liquid-tight sloped or recessed floors in indoor locations.
2. ... Liquid-tight floors in indoor locations provided with liquid-tight raised or recessed sills or dikes.
3. ... Sumps and collection systems.
4. ... Drainage systems leading to an approved location.
5. ... Other approved engineered systems.

415.12.2.2 Incompatible materials. Incompatible materials used in open systems shall be separated from each other in the secondary containment system.

415.12.2.3 Indoor design. Secondary containment for indoor storage areas shall be designed to contain a spill from the largest vessel plus the design flow volume of fire protection water calculated to discharge from the fire-extinguishing system over the minimum required system design area or area of the room or area in which the storage is located, whichever is smaller. The containment capacity shall be designed to contain the flow for a period of 20 minutes.

415.12.2.4 Monitoring. An approved monitoring method shall be provided to detect hazardous materials in the secondary containment system. The monitoring method is allowed to be visual inspection of the primary or secondary containment, or other approved means. Where secondary containment is subject to the intrusion of water, a monitoring method for detecting water shall be provided. Where monitoring devices are provided, they shall be connected to approved visual or audible alarms.

415.12.2.5 Drainage system design. Drainage systems shall be in accordance with the *Plumbing Code* and all of the following:

1. The slope of floors to drains in indoor locations or similar areas in outdoor locations shall be not less than 1 percent.
2. Drains from indoor storage areas shall be sized to carry the volume of the fire protection water as determined by the design density discharged from the automatic fire-extinguishing system over the minimum required system design area or area of the room or area in which the storage is located, whichever is smaller.

**TABLE 415.12.2
REQUIRED SECONDARY CONTAINMENT HAZARDOUS
MATERIAL SOLIDS AND LIQUIDS STORAGE**

MATERIAL	INDOOR STORAGE		
	Solids	Liquids	
1. Physical-hazard materials			
Combustible liquids	Class II	Not Applicable	See Section 444
	Class IIIA		See Section 444
	Class IIIB		See Section 444
Cryogenic fluids			See Section 442
Explosives			See Section 443
Flammable liquids	Class IA	Not Applicable	See Section 444
	Class IB		See Section 444
	Class IC		See Section 444
Flammable solids	Not Required	Not Applicable	
Organic peroxides	Unclassified Detonable	Required	Required
	Class I		
	Class II		
	Class III		
	Class IV		
	Class V	Not Required	Not Required
Oxidizers	Class 4	Required	Required
	Class 3		
	Class 2	Not Required	Not Required
	Class 1		
Pyrophorics	Not Required	Required	
Unstable (reactives)	Class 4	Required	Required
	Class 3		
	Class 2		
	Class 1		
Water reactives	Class 3	Required	Required
	Class 2		
	Class 1	Not Required	Not Required
2. Health-hazard materials			
Corrosives	Not Required	Required	
Highly toxics	Required	Required	
Toxics			

3. Materials of construction for drainage systems shall be compatible with the materials stored.
4. Incompatible materials used in open systems shall be separated from each other in the drainage system.
5. Drains shall terminate in an approved location away from buildings, valves, means of egress, fire access roadways, adjoining property and storm drains.

415.12.3 Ventilation. Indoor storage areas and storage buildings shall be provided with mechanical exhaust ventilation or natural ventilation where natural ventilation can be shown to be acceptable for the materials as stored.

Exception: Storage areas for flammable solids complying with Section 446.

415.12.3.1 System requirements. Exhaust ventilation systems shall comply with all of the following:

1. Installation shall be in accordance with the *Mechanical Code*.
2. Mechanical ventilation shall be at a rate of not less than 1 cubic foot per minute per square foot [0.00508 m³/(s × m²)] of floor area over the storage area.
3. Systems shall operate continuously unless alternative designs are approved.
4. A manual shutoff control shall be provided outside the room in a position adjacent to the access door to the room or in an approved location. The switch shall be a break-glass or other approved type and shall be labeled: **VENTILATION SYSTEM EMERGENCY SHUTOFF**.
5. Exhaust ventilation shall be designed to consider the density of the potential fumes or vapors released.
For fumes or vapors that are heavier than air, exhaust shall be taken from a point within 12 inches (305 mm) of the floor. For fumes or vapors that are lighter than air, exhaust shall be taken from a point within 12 inches (305 mm) of the highest point of the room.
6. The location of both the exhaust and inlet air openings shall be designed to provide air movement across all portions of the floor or room to prevent the accumulation of vapors.
7. Exhaust air shall not be recirculated to occupied areas if the materials stored are capable of emitting hazardous vapors and contaminants have not been removed. Air contaminated with explosive or flammable vapors, fumes or dusts; flammable, highly toxic or toxic gases; or radioactive materials shall not be recirculated.

415.12.4 Separation of incompatible hazardous materials. Incompatible materials shall be separated in accordance with Section 414.19.

415.12.5 Explosion control. Indoor storage rooms, areas and buildings shall be provided with explosion control in accordance with Section 919.

415.12.6 Standby or emergency power. Where mechanical ventilation, treatment systems, temperature control, alarm, detection or other electrically operated systems are required, such systems shall be provided with an emergency or standby power in accordance with Section 2702. For storage areas for highly toxic or toxic materials, see Section 447.

415.12.6.1 Exempt applications. Standby or emergency power is not required for mechanical ventilation systems for any of the following:

1. Storage of Class IB and IC flammable liquids and Class II and III combustible liquids in closed containers not exceeding a capacity of 6½ gallons (25 L).
2. Storage of Class 1 and 2 oxidizers.

3. Storage of Class II, III, IV and V organic peroxides.
4. Storage of asphyxiant, irritant and radioactive gases.

415.12.6.2 Fail-safe engineered systems. Standby power for mechanical ventilation, treatment systems and temperature control systems shall not be required where an *approved* fail-safe engineered system is installed.

415.12.7 Limit controls. Limit controls shall be provided in accordance with Sections 415.12.7.1 and 415.12.7.2.

415.12.7.1 Temperature control. Materials that must be kept at temperatures other than normal ambient temperatures to prevent a hazardous reaction shall be provided with an *approved* means to maintain the temperature within a safe range. Redundant temperature control equipment that will operate on failure of the primary temperature control system shall be provided. Where *approved*, alternative means that prevent a hazardous reaction are allowed.

415.12.7.2 Pressure control. Stationary tanks and equipment containing hazardous material liquids that can generate pressures exceeding design limits because of exposure fires or internal reaction shall have some form of construction or other *approved* means that will relieve excessive internal pressure. The means of pressure relief shall vent to an *approved* location or to an exhaust scrubber or treatment system where required by Section 447.

415.12.8 Noncombustible floor. Except for surfacing, floors of storage areas shall be of noncombustible construction.

415.12.9 Weather protection. Where overhead noncombustible construction is provided for sheltering outdoor *hazardous materials* storage areas, such storage shall not be considered indoor storage where the area is constructed in accordance with the requirements for weather protection as required by Section 414.6.

415.13 Hazardous materials use, dispensing and handling. Use, dispensing and handling of *hazardous materials* in amounts exceeding the *maximum allowable quantity per control area* shall be in accordance with Section 414 and Sections 415.13.1 through 415.13.13.

415.13.1 Separation of incompatible materials. Separation of *incompatible materials* shall be in accordance with Section 414.19.

415.13.2 Noncombustible floor. Except for surfacing, floors of areas where liquid or solid *hazardous materials* are dispensed or used in *open systems* shall be of noncombustible, liquid-tight construction.

415.13.3 Spill control and secondary containment for hazardous material liquids. Where required by other provisions of Section 415.13, spill control and *secondary containment* shall be provided for hazardous material liquids in accordance with Section 415.12.1.

415.13.4 Limit controls. Limit controls shall be provided in accordance with Sections 415.13.4.1 through 415.13.4.4.

415.13.4.1 High-liquid-level control. Open tanks in which liquid *hazardous materials* are used shall be equipped with a liquid-level limit control or other means to prevent overfilling of the tank.

415.13.4.2 Low-liquid-level control. *Approved* safeguards shall be provided to prevent a low liquid level in a tank from creating a hazardous condition, including but not limited to overheating of a tank or its contents.

415.13.4.3 Temperature control. Temperature control shall be provided in accordance with Section 415.12.7.1.

415.13.4.4 Pressure control. Pressure control shall be provided in accordance with Section 415.12.7.2.

415.13.5 Standby or emergency power. Where mechanical ventilation, treatment systems, temperature control, manual alarm, detection or other electrically operated systems are required by this code, such systems shall be provided with emergency or standby power in accordance with Section 2702.

415.13.5.1 Exempt applications. Standby power for mechanical ventilation, treatment systems and temperature control systems shall not be required where an *approved* fail-safe engineered system is installed.

415.13.6 Supervision and monitoring. Manual alarm, detection and automatic fire-extinguishing systems required by other provisions of Section 415.13 shall be electrically supervised and monitored by an *approved* supervisory service or, where *approved*, shall initiate an audible and visual signal at a constantly attended on-site location.

415.13.7 Lighting. Adequate lighting by natural or artificial means shall be provided.

415.13.8 Fire protection systems. Indoor rooms or areas in which *hazardous materials* are dispensed or used shall be protected by an *automatic sprinkler system* or automatic fire-extinguishing system in accordance with Chapter 9. Sprinkler system design shall be not less than that required for Ordinary Hazard Group 2, with a minimum design area of 3,000 square feet (279 m²). Where the materials or storage arrangement is required by other regulations to be provided with a higher level of sprinkler system protection, the higher level of sprinkler system protection shall be provided.

415.13.9 Ventilation. Indoor dispensing and use areas shall be provided with exhaust ventilation in accordance with Section 415.12.3.

Exception: Ventilation is not required for dispensing and use of flammable solids other than finely divided particles.

415.13.10 Liquid transfer. Liquids having a hazard ranking of 3 or 4 in accordance with NFPA 704 shall be transferred by one of the following methods:

1. From *safety cans* complying with UL 30.
2. Through an *approved* closed piping system.
3. From *containers* or tanks by an *approved* pump taking suction through an opening in the top of the *container* or tank.
4. From *containers* or tanks by gravity through an *approved* self-closing or automatic-closing valve where the *container* or tank and dispensing operations are provided with *spill control* and *secondary containment* in accordance with Section 415.12.1. Highly toxic liquids shall not be dispensed by gravity from tanks.
5. *Approved* engineered liquid transfer systems.

Exceptions:

1. Liquids having a hazard ranking of 4 where dispensed from *approved containers* not exceeding 1.3 gallons (5 L).
2. Liquids having a hazard ranking of 3 where dispensed from *approved containers* not exceeding 5.3 gallons (20 L).

415.13.11 Design. Systems shall be suitable for the use intended and shall be designed by persons competent in such design. Controls shall be designed to prevent materials from entering or leaving the process or reaction system at other than the intended time, rate or path. Where failure of an automatic control could result in a dangerous condition or reaction, the automatic control shall be fail-safe.

415.13.12 Indoor dispensing and use. Indoor dispensing and use of *hazardous materials* shall be in buildings complying with this code and in accordance with Section 415.13.1 and Sections 415.13.12.1 through 415.13.12.4.

415.13.12.1 Open systems. Dispensing and use of *hazardous materials* in open *containers* or systems shall be in accordance with Sections 415.13.12.1.1 through 415.13.12.1.4.

415.13.12.1.1 Ventilation. Where gases, liquids or solids having a hazard ranking of 3 or 4 in accordance with NFPA 704 are dispensed or used, mechanical exhaust ventilation shall be provided to capture gases, fumes, mists or vapors at the point of generation.

Exception: Gases, liquids or solids that can be demonstrated not to create harmful gases, fumes, mists or vapors.

415.13.12.1.2 Explosion control. Explosion control shall be provided in accordance with Section 415.12.5 where an explosive environment can occur because of the characteristics or nature of the *hazardous materials* dispensed or used, or as a result of the dispensing or use process.

415.13.12.1.3 Spill control for hazardous material liquids. Buildings, rooms or areas where hazardous material liquids are dispensed into vessels exceeding a 1.3-gallon (5 L) capacity or used in *open systems* exceeding a 5.3-gallon (20 L) capacity shall be provided with spill control in accordance with Section 415.12.1.1.

415.13.12.1.4 Secondary containment for hazardous material liquids. Where required by Table 415.13.12.1.4, buildings, rooms or areas where hazardous material liquids are dispensed or used in *open systems* shall be provided with *secondary containment* in accordance with Section 415.12.2 where the capacity of an individual vessel or system or the capacity of multiple vessels or systems exceeds the following:

1. Individual vessel or system: greater than 1.3 gallons (5 L).
2. Multiple vessels or systems: greater than 5.3 gallons (20 L).

**TABLE 415.13.12.1.4
REQUIRED SECONDARY CONTAINMENT—HAZARDOUS
MATERIAL LIQUIDS USE**

MATERIAL	INDOOR LIQUIDS USE	
1. Physical-hazard materials		
Combustible liquids	Class II	See Section 444
	Class IIIA	See Section 444
	Class IIIB	See Section 444
Cryogenic fluids		See Section 442
Explosives		See Section 443
Flammable liquids	Class IA	See Section 444
	Class IB	See Section 444
	Class IC	See Section 444
Flammable solids		Not Applicable
Organic peroxides	Unclassified Detonable	Required
	Class I	Required
	Class II	
	Class III	
	Class IV	
Oxidizers	Class V	Not Required
	Class 4	Required
	Class 3	
	Class 2	
Class 1		
Pyrophorics		Required
Unstable (reactives)	Class 4	Required
	Class 3	
	Class 2	
	Class 1	Not Required
Water reactives	Class 3	Required
	Class 2	Required
	Class 1	Not Required
2. Health-hazard materials		
Corrosives		Required
Highly toxics		
Toxics		

415.13.12.2. Closed systems. Use of *hazardous materials* in *closed containers* or systems shall be in accordance with Sections 415.13.12.2.1 through 415.13.12.2.4.

415.13.12.2.1 Ventilation. Where *closed systems* are designed to be opened as part of normal operations, ventilation shall be provided in accordance with Section 415.13.12.1.1.

415.13.12.2.2 Explosion control. Explosion control shall be provided in accordance with Section 415.12.5 where an explosive environment exists because of the *hazardous materials* dispensed or used, or as a result of the dispensing or use process.

Exception: Where process vessels are designed to contain fully the worst-case explosion anticipated within the vessel under process conditions based on the most likely failure.

415.13.12.2.3 Spill control for hazardous material liquids. Buildings, rooms or areas where hazardous material liquids are used in individual vessels exceeding a 55-gallon (208 L) capacity shall be provided with spill control in accordance with Section 415.12.1.1.

415.13.12.2.4 Secondary containment for hazardous material liquids. Where required by Table 415.13.12.1.4, buildings, rooms or areas where hazardous material liquids are used in vessels or systems shall be provided with *secondary containment* in accordance with Section 415.12.2 where the capacity of an individual vessel or system or the capacity of multiple vessels or systems exceeds the following:

1. Individual vessel or system: greater than 55 gallons (208 L).
2. Multiple vessels or systems: greater than 1,000 gallons (3785 L).

415.13.13 Weather protection. Where overhead noncombustible construction is provided for sheltering outdoor hazardous material use areas, such use shall not be considered indoor use where the area is constructed in accordance with the requirements for weather protection as required in Section 414.6.

Section 416 ~~Spray~~ Application of Flammable Finishes

IBC 416

416.1 General. The provisions of this section shall apply to the construction, installation and use of buildings and structures, or parts thereof, ~~for the spray application of flammable finishes. Operations and equipment shall comply with the International Fire Code, where any of the following activities are conducted:~~

1. The application of *flammable finishes* to articles or materials by means of spray apparatus.
2. The application of *flammable finishes* by dipping or immersing articles or materials into the contents of tanks, vats or *containers* of *flammable* or *combustible liquids* for coating, finishing, treatment or similar processes.
3. The application of *flammable finishes* by applying *combustible* powders to articles or materials utilizing powder spray guns, electrostatic powder spray guns, *fluidized beds* or *electrostatic fluidized beds*.
4. Floor surfacing or finishing operations using Class I or II liquids in areas exceeding 350 square feet (32.5 m²).
5. The application of *flammable finishes* consisting of dual-component coatings or Class I or II liquids where applied by brush or roller in quantities exceeding 1 gallon (4 L).

416.1.1 Nonapplicability. This section shall not apply to spray finishing utilizing flammable or *combustible liquids* that do not sustain combustion, including:

1. Liquids that do not have a fire point when tested in accordance with ASTM D92.
2. Liquids with a flashpoint greater than 95°F (35°C) in a water-miscible solution or dispersion with a water and inert (noncombustible) solids content of more than 80 percent by weight.

416.2 Protection of operations. Operations covered by this section shall be protected as required by Sections 416.2.1 through 416.2.1.4.

416.2.1 Sources of ignition. Protection against sources of ignition shall be provided in accordance with Sections 416.2.1.1 through 416.2.1.4 and the *Electrical Code*.

416.2.1.1 Electrical wiring and equipment. Electrical wiring and equipment shall comply with the *Electrical Code*.

416.2.1.2 Flammable vapor areas. Electrical wiring and equipment in *flammable vapor areas* shall be of an explosion-proof type approved for use in such hazardous locations. Such areas shall be classified in accordance with the *Electrical Code*.

416.2.1.3 Areas adjacent to spray booths. Electrical wiring and equipment located outside of, but within 3 feet (914 mm) of openings in a spray booth or a spray room, shall be approved for Class I, Division 2, or Class II, Division 2, hazardous locations, whichever is applicable, and installed in accordance with the *Electrical Code*.

416.2.1.4 Areas subject to overspray deposits. Electrical equipment in flammable vapor areas located such that deposits of combustible residues could readily accumulate thereon shall be specifically approved for locations containing deposits of readily ignitable residue and explosive vapors in accordance with the *Electrical Code*.

416.2.1.5 Open flames and sparks. Open flames and spark-producing devices shall not be located in *flammable vapor areas* and shall not be located within 20 feet (6096 mm) of such areas unless separated by a permanent partition.

Exception: Drying and baking apparatus complying with Section 416.3.4.2.

416.2.1.6 Grounding. Metal parts of *spray booths*, exhaust ducts and piping systems conveying Class I or II liquids shall be electrically grounded in accordance with the *Electrical Code*. Metallic parts located in resin application areas, including but not limited to exhaust ducts, ventilation fans, spray application equipment, workpieces and piping, shall be electrically grounded.

416.2.1.7 Welding warning signs. Welding, cutting and similar spark-producing operations shall not be conducted in or adjacent to *flammable vapor areas* or dipping or coating operations unless precautions have been taken to provide safety. Conspicuous signs with the following warning shall be posted in the vicinity of *flammable vapor areas*, dipping operations and paint storage rooms:

NO WELDING THE USE OF WELDING OR CUTTING EQUIPMENT IN OR NEAR THIS AREA IS DANGEROUS BECAUSE OF FIRE AND EXPLOSION HAZARDS. WELDING AND CUTTING SHALL BE DONE ONLY UNDER THE SUPERVISION OF THE PERSON IN CHARGE.

416.3 Spray finishing. The application of flammable or *combustible liquids* by means of spray apparatus in continuous or intermittent processes shall be in accordance with the requirements of Section 416.2.1 and Sections 416.3.1 through 416.3.7.4.

416.3.1 Location of spray-finishing operations. Spray-finishing operations conducted in buildings used for Group A, E, I or R occupancies shall be located in a spray room protected with an *approved automatic sprinkler system* installed in accordance with Section 903.3.1.1 and separated vertically and horizontally from the remainder of the building by *fire barrier* walls and horizontal assemblies with not less

than a 1-hour *fire-resistance rating* in accordance with this code. In other occupancies, spray-finishing operations shall be conducted in a spray room, *spray booth* or *limited spraying space* approved for such use.

Exceptions:

1. Automobile undercoating spray operations and spray-on automotive lining operations conducted in areas with *approved* natural or mechanical ventilation shall be exempt from the provisions of Section 416.3 where *approved* and where utilizing Class IIIA or IIIB *combustible liquids*.
2. In buildings other than Group A, E, I or R occupancies, *approved limited spraying space* in accordance with Section 416.3.7.
3. Resin application areas used for manufacturing of reinforced plastics complying with Section 416.8 shall not be required to be located in a spray room, *spray booth* or *spraying space*.

416.3.2 Design and construction. Design and construction of spray rooms, spray spaces and *spray booths* shall be in accordance with Sections 416.3.2.1 through 416.3.2.3.6.

416.3.2.1 Spray rooms. Spray rooms shall be constructed and designed in accordance with Sections 416.3.2.1.1 through 416.3.2.1.4 and shall comply with Sections 416.3.3 through 416.3.6.

416.3.2.1.1 Construction. ~~416.2 Spray rooms.~~ *Spray rooms* shall be enclosed with not less than 1-hour *fire barriers* constructed in accordance with Section 707 or *horizontal assemblies* constructed in accordance with Section 711, or both.

416.2.1 Construction. Walls and ceilings of *spray rooms* shall be constructed of noncombustible materials or the interior surface shall be completely covered with noncombustible materials. Aluminum shall not be used.

416.3.2.1.2 ~~416.2.2 Surfaces.~~ The *interior surfaces* of *spray rooms* shall be smooth and shall be so constructed to permit the free passage of exhaust air from all parts of the interior and to facilitate washing and cleaning, and shall be so designed to confine residues within the room.

416.3.2.1.3 Floors. Floors shall be waterproofed and drained in an *approved* manner. *Combustible floor construction in spray rooms shall be covered by approved, noncombustible, nonsparking material*, except where combustible coverings, including but not limited to thin paper or plastic and strippable coatings, are utilized over noncombustible materials to facilitate cleaning operations in spray rooms.

416.3.2.1.4 ~~416.2.3 Ventilation.~~ Mechanical *ventilation* and interlocks with the spraying operation shall be in accordance with ~~this code~~ *the International Fire Code* and ~~International~~ *the Mechanical Code*.

~~416.3.2.2~~ **416.3 Spraying spaces.** *Spraying spaces shall be designed and constructed in accordance with Sections 416.3.2.2.1 through 416.3.2.2.3 and Sections 416.3.3 through 416.3.6.*

416.3.2.2.1 Ventilation. Spraying spaces shall be ventilated with an exhaust system to prevent the accumulation of flammable mist or vapors in accordance with the ~~International—Mechanical Code~~. Where such spaces are not separately enclosed, noncombustible spray curtains shall be provided to restrict the spread of flammable vapors.

416.3.2.2.2 ~~416.3.1~~—Surfaces. The *interior surfaces* of spraying spaces shall be smooth; shall be so constructed to permit the free passage of exhaust air from all parts of the interior and to facilitate washing and cleaning; and shall be so designed to confine residues within the spraying space. Aluminum shall not be used.

416.3.2.2.3 Floors. *Combustible floor construction in spraying spaces shall be covered by approved, noncombustible, nonsparking material, except where combustible coverings such as thin paper or plastic and strippable coatings are utilized over noncombustible materials to facilitate cleaning operations in spraying spaces.*

~~416.3.2.3~~ **416.4 Spray booths.** *Spray booths shall be designed, constructed and operated in accordance with the ~~International Fire Code~~. The design and construction of spray booths shall be in accordance with Sections 416.3.2.3.1 through 416.3.2.3.6, Sections 416.3.3 through 416.3.6 and NFPA 33.*

416.3.2.3.1 Construction. *Spray booths shall be constructed of approved noncombustible materials. Aluminum shall not be used. Where walls or ceiling assemblies are constructed of sheet metal, single-skin assemblies shall be not thinner than 0.0478 inch (18 gage) (1.2 mm) and each sheet of double-skin assemblies shall be not thinner than 0.0359 inch (20 gage) (0.9 mm). Structural sections of spray booths are allowed to be sealed with latex-based or similar caulks and sealants.*

416.3.2.3.2 Surfaces. *The interior surfaces of spray booths shall be smooth; shall be constructed so as to permit the free passage of exhaust air from all parts of the interior, and to facilitate washing and cleaning; and shall be designed to confine residues within the booth. Aluminum shall not be used.*

416.3.2.3.3 Floors. *Combustible floor construction in spray booths shall be covered by approved, noncombustible, nonsparking material, except where combustible coverings, including but not limited to thin paper or plastic and strippable coatings, are utilized over noncombustible materials to facilitate cleaning operations in spray booths.*

416.3.2.3.4 Means of egress. *Means of egress shall be provided in accordance with Chapter 10.*

Exception: *Means of egress doors from premanufactured spray booths shall be not less than 30 inches (762 mm) in width by 80 inches (2032 mm) in height.*

416.3.2.3.5 Clear space. *Spray booths shall be installed so that all parts of the booth are able to be accessed for cleaning.*

Exceptions:

- 1. This requirement shall not prohibit locating a spray booth closer than 3 feet (914 mm) to or directly against an interior partition, wall or floor/ceiling assembly that has a fire-resistance rating of not less than 1 hour, provided that the spray booth can be adequately maintained and cleaned.*
- 2. This requirement shall not prohibit locating a spray booth closer than 3 feet (914 mm) to an exterior wall or a roof assembly, provided that the wall or roof is constructed of noncombustible material and the spray booth can be adequately maintained and cleaned.*

416.3.2.3.6 Size. *The aggregate area of spray booths in a building shall not exceed the lesser of 10 percent of the area of any floor of a building or the basic area allowed for a Group H-2 occupancy without area increases, as set forth in this code.*

Exception: *One individual booth not exceeding 500 square feet (46 m²).*

~~416.3.3~~ **416.5—Fire protection.** *An automatic sprinkler system or fire-extinguishing system shall be provided in all spray rooms and spray booths, and shall be installed in accordance with Chapter 9. Protection shall extend to exhaust plenums, exhaust ducts and both sides of dry filters where such filters are used.*

416.3.3.1 Protection of sprinklers. *Automatic sprinklers installed in flammable vapor areas shall be protected from the accumulation of residue from spraying operations in an approved manner. Bags used as a protective covering shall be 0.003-inch-thick (0.076 mm) polyethylene or cellophane or shall be thin paper. Automatic sprinklers contaminated by overspray particles shall be replaced with new automatic sprinklers.*

416.3.4 Sources of ignition. *Control of sources of ignition shall be in accordance with Section 416.2.1 and Sections 416.3.4.1 through 416.3.4.2.1.*

416.3.4.1 Drying operations. *Spray booths and spray rooms shall not be alternately used for the purpose of drying by arrangements or methods that could cause an increase in the surface temperature of the spray booth or spray room except in accordance with Section 416.3.4.2. Except as specifically provided in this section, drying or baking units utilizing a heating system having open flames or that are capable of producing sparks shall not be installed in a flammable vapor area.*

416.3.4.2 Drying apparatus. Fixed drying apparatus shall comply with Section 416 and the applicable provisions of Section 434. Where recirculation ventilation is provided in accordance with the *Mechanical Code*, the heating system shall not be within the recirculation air path.

416.3.4.2.1 Interlocks. The spraying apparatus, drying apparatus and ventilating system for the *spray booth* or spray room shall be equipped with interlocks arranged to accomplish all of the following:

1. Prevent operation of the spraying apparatus while drying operations are in progress.
2. Where the drying apparatus is located in the *spray booth* or spray room, prevent operation of the drying apparatus until a timed purge of spray vapors from the *spray booth* or spray room is complete. This purge time shall be based on completing not fewer than four air changes of *spray booth* or spray room volume or for a period of not less than 3 minutes, whichever is greater.
3. Have the ventilating system maintain a safe atmosphere within the *spray booth* or spray room during the drying process and automatically shut off drying apparatus in the event of a failure of the ventilating system.
4. Shut off the drying apparatus automatically if the air temperature within the booth exceeds 200°F (93°C).

416.3.5 Ventilation. Mechanical ventilation of *flammable vapor areas* shall be provided in accordance with Section 502.7 of the *Mechanical Code*.

416.3.5.1 Filters. Air intake filters that are part of a wall or ceiling assembly shall be *listed* as Class I or II in accordance with UL 900. Exhaust filters shall be required.

416.3.5.1.1 Supports. Supports and holders for filters shall be constructed of noncombustible materials.

416.3.5.1.2 Attachment. Overspray collection filters shall be readily removable and able to be accessed for cleaning or replacement.

416.3.5.1.3 Maintaining air velocity. Visible gauges, audible alarms or pressure-activated devices shall be installed to indicate or ensure that the required air velocity is maintained.

416.3.5.1.4 Filter rolls. *Spray booths* equipped with a filter roll that is automatically advanced when the air velocity is reduced to less than 100 feet per minute (0.51 m/s) shall be arranged to shut down the spraying operation if the filter roll fails to advance automatically.

416.3.5.1.5 Waterwash spray booths. Waterwash *spray booths* shall be of an *approved* design so as to prevent excessive accumulation of deposits in ducts and residue at duct outlets. Such booths shall be arranged so that air and overspray are drawn through a continuously flowing water curtain before entering an exhaust duct to the building exterior.

416.3.6 Interlocks. Interlocks for spray application finishes shall be in accordance with Sections 416.3.6.1 and 416.3.6.2.

416.3.6.1 Automated spray application operations. Where protecting automated spray application operations, automatic fire-extinguishing systems shall be equipped with an *approved* interlock feature that will, upon discharge of the system, automatically stop the spraying operations and workpiece conveyors into and out of the *flammable vapor areas*. Where the building is equipped with a *fire alarm system*, discharge of the *automatic fire-extinguishing system* shall also activate the building alarm notification appliances.

416.3.6.1.1 Alarm station. A manual fire alarm and emergency system shutdown station shall be installed to serve each *flammable vapor area*. When activated, the station shall accomplish the functions indicated in Section 416.3.6.1.

416.3.6.1.2 Alarm station location. Not less than one manual fire alarm and emergency system shutdown station shall be provided with *ready access* for operating personnel. Where access to this station is likely to involve exposure to danger, an additional station shall be located adjacent to an *exit* from the area.

416.3.6.2 Ventilation interlock prohibited. Air makeup and *flammable vapor area* exhaust systems shall not be interlocked with the fire alarm system and shall remain in operation during a fire alarm condition.

Exception: Where the type of fire-extinguishing system used requires such ventilation to be discontinued, air makeup and exhaust systems shall shut down and dampers shall close.

416.3.7 Limited spraying spaces. *Limited spraying spaces* shall comply with Sections 416.3.7.1 through 416.3.7.4.

416.3.7.1 Job size. The aggregate surface area to be sprayed shall not exceed 9 square feet (0.84 m²).

416.3.7.2 Frequency. Spraying operations shall not be of a continuous nature.

416.3.7.3 Ventilation. Positive mechanical ventilation providing not fewer than six complete air changes per hour shall be installed. Such systems shall meet the requirements of this code for handling *flammable vapor areas*. Explosion venting is not required.

416.3.7.4 Electrical wiring. Electrical wiring within 10 feet (3048 mm) of the floor and 20 feet (6096 mm) horizontally of the *limited spraying space* shall be in accordance with the *Electrical Code*.

416.4 Dipping applications. Dip-tank operations shall comply with the requirements of Section 416.2 and Sections 416.4.1 through 416.4.5.

416.4.1 Location of dip-tank operations. Dip-tank operations conducted in buildings used for Group A, I or R occupancies shall be located in a room designed for that purpose, equipped with an *approved automatic sprinkler system* and separated vertically and horizontally from other areas in accordance with this code.

416.4.2 Construction of dip tanks. *Dip tanks* shall be constructed in accordance with Sections 416.4.2.1 through 416.4.3.2 and NFPA 34. *Dip tanks*, including drain boards, shall be constructed of noncombustible material and their supports shall be of heavy metal, reinforced concrete or masonry.

416.4.2.1 Overflow. *Dip tanks* greater than 150 gallons (568 L) in capacity or 10 square feet (0.93 m²) in liquid surface area shall be equipped with a trapped overflow pipe leading to an *approved outdoor location*. The bottom of the overflow connection shall be not less than 6 inches (152 mm) below the top of the tank.

416.4.2.2 Bottom drains. *Dip tanks* greater than 500 gallons (1893 L) in liquid capacity shall be equipped with bottom drains that are arranged to automatically and manually drain the tank quickly in the event of a fire unless the viscosity of the liquid at normal atmospheric temperature makes this impractical. Access to the manual operation shall be from a safe location. Where gravity flow is not practicable, automatic pumps shall be provided. Such drains shall be trapped and discharged to a closed, vented, salvage tank or to an *approved outdoor location*.

Exception: *Dip tanks* containing Class IIIB combustible liquids where the liquids are not heated above room temperature and the process area is protected by automatic sprinklers.

416.4.2.3 Dipping liquid temperature control. Protection against the accumulation of vapors, self-ignition and excessively high temperatures shall be provided for dipping liquids that are heated directly or heated by the surfaces of the object being dipped.

416.4.2.4 Dip-tank covers. Dip-tank covers allowed by Section 416.4.3.1 shall be capable of manual operation and shall be automatic closing by *approved automatic-closing devices* designed to operate in the event of a fire.

416.4.2.4.1 Construction. Covers shall be constructed of noncombustible material or be of a tin-clad type with enclosing metal applied with locked joints.

416.4.2.4.2 Supports. Chain or wire rope shall be utilized for cover supports or operating mechanisms.

416.4.3 Fire protection. Dip-tank operations shall be protected in accordance with Sections 416.4.3.1 and 416.4.3.2.

416.4.3.1 Fixed fire-extinguishing equipment. An *approved automatic fire-extinguishing system* or diptank cover in accordance with Section 416.4.2.4 shall be provided for the following *dip tanks*:

1. *Dip tanks* less than 150 gallons (568 L) in capacity or 10 square feet (0.93 m²) in liquid surface area.
2. *Dip tanks* containing a liquid with a *flash point* below 110°F (43°C) used in such manner that the liquid temperature could equal or be greater than its *flash point* from artificial or natural causes and having both a capacity of more than 10 gallons (37.9 L) and a liquid surface area of more than 4 square feet (0.37 m²).

416.4.3.2 Fire-extinguishing system. An *approved automatic fire-extinguishing system* shall be provided for *dip tanks* with a 150-gallon (568 L) or more capacity or 10 square feet (0.93 m²) or larger liquid surface area. Fire-extinguishing system design shall be in accordance with NFPA 34.

416.4.4 Sources of ignition. Control of sources of ignition shall be in accordance with Section 416.2.1.

416.4.5 Ventilation of flammable vapor areas. *Flammable vapor areas* shall be provided with mechanical ventilation adequate to prevent the dangerous accumulation of vapors. Required ventilation systems shall be arranged such that the failure of any ventilating fan shall automatically stop the dipping conveyor system.

416.4.6 Conveyor interlock. *Dip tanks* utilizing a conveyor system shall be arranged such that in the event of a fire, the conveyor system shall automatically cease motion and the required tank bottom drains shall open.

416.4.7 Hardening and tempering tanks. Hardening and tempering tanks shall comply with Sections 416.4.2 through 416.4.2.3 and Section 416.4.6 but shall be exempt from other provisions of Section 416.4.

416.4.7.1 Location. Tanks shall be located as far as practical from furnaces and shall not be located on or near combustible floors.

416.4.7.2 Hoods. Tanks shall be provided with a noncombustible hood and vent or other *approved* venting means, terminating outside the structure to serve as a vent in case of a fire. Such vent ducts shall be treated as flues and proper clearances shall be maintained from combustible materials.

416.4.7.3 Alarms. Tanks shall be equipped with a high-temperature limit switch arranged to sound an alarm when the temperature of the quenching medium reaches 50°F (10°C) below the *flash point*.

416.4.7.4 Fire protection. Hardening and tempering tanks greater than 500 gallons (1893 L) in capacity or 25 square feet (2.3 m²) in liquid surface area shall be protected by an *approved automatic fire-extinguishing system* complying with Chapter 9.

416.4.7.5 Use of air pressure. Air under pressure shall not be used to fill or agitate oil in tanks.

416.4.8 Flow-coating operations. Flow-coating operations shall comply with the requirements for *dip tanks*. The area of the sump and any areas on which paint flows shall be considered to be the area of a *dip tank*.

416.4.8.1 Paint supply. Paint shall be supplied by a gravity tank not exceeding 10 gallons (38 L) in capacity or by direct low-pressure pumps arranged to shut down automatically in case of a fire by means of *approved* heat-actuated devices.

416.4.9 Roll-coating operations. Roll-coating operations shall comply with Section 416.4.4. In roll-coating operations utilizing flammable or *combustible liquids*, sparks from static electricity shall be prevented by electrically bonding and grounding all metallic parts of machinery and equipment, including rotating parts, and by the installation of static collectors, or by maintaining a conductive atmosphere such as high relative humidity.

416.5 Powder coating. Operations using finely ground particles of protective finishing material applied in dry powder form by a *fluidized bed*, an *electrostatic fluidized bed*, powder spray guns or electrostatic powder spray guns shall comply with Sections 416.5.1 through 416.5.5. In addition, Section 416.6 shall apply to fixed electrostatic equipment used in powder coating operations.

416.5.1 Location. Powder coating operations shall be conducted in enclosed powder coating rooms, enclosed powder coating facilities that are ventilated or ventilated *spray booths*.

416.5.2 Construction of powder coating rooms and booths. Powder coating rooms shall be constructed of noncombustible materials. *Spray booths* shall be constructed in accordance with Section 416.3.2.3.

Exception: *Listed* spray-booth assemblies that are constructed of other materials shall be allowed.

416.5.3 Fire protection. Areas used for powder coating shall be protected by an *approved automatic fire-extinguishing system* complying with Chapter 9.

416.5.3.1 Additional protection for fixed systems. Automated powder application equipment shall be protected by the installation of an *approved*, supervised flame detection apparatus that shall react to the presence of flame within 0.5 second and shall accomplish all of the following:

1. Shutting down of energy supplies (electrical and compressed air) to conveyor, ventilation, application, transfer and powder collection equipment.
2. Closing of segregation dampers in associated ductwork to interrupt airflow from application equipment to powder collectors.
3. Activation of an alarm that is audible throughout the powder coating room or booth.

416.5.4 Sources of ignition. Control of sources of ignition shall be in accordance with Section 416.2.1 and Sections 416.5.4.1 and 416.5.4.2.

416.5.4.1 Drying, curing and fusion equipment. Drying, curing and fusion equipment shall comply with Section 434. **416.5.4.2 Grounding and bonding.** Precautions shall be taken to minimize the possibility of ignition by static electrical sparks through static bonding and grounding, where possible, of powder transport, application and recovery equipment.

416.5.5 Ventilation. Exhaust ventilation shall be sufficient to maintain the atmosphere below one-half the minimum *explosive* concentration for the material being applied. Nondeposited, air-suspended powders shall be removed through exhaust ducts to the powder recovery system.

416.6 Electrostatic apparatus. Electrostatic apparatus and devices used in connection with paint-spraying and paint-deteared operations shall be of an *approved* type.

416.6.1 Location and clear space. A space of not less than twice the sparking distance shall be maintained between goods being painted or *deteared* and electrodes, electrostatic atomizing heads or conductors. A sign stating the sparking distance shall be conspicuously posted near the assembly.

Exception: Portable electrostatic paint-spraying apparatus *listed* for use in Class I, Division 1, locations.

416.6.2 Construction of equipment. Electrodes and electrostatic atomizing heads shall be of *approved* construction, rigidly supported in permanent locations and effectively insulated from ground. Insulators shall be nonporous and noncombustible.

Exception: Portable electrostatic paint-spraying apparatus *listed* for use in Class I, Division 1, locations.

416.6.2.1 Barriers. Booths, fencing, railings or guards shall be placed about the equipment such that either by their location or character or both, isolation of the process is maintained from plant storage and personnel. Railings, fencing and guards shall be of conductive material, adequately grounded, and not less than 5 feet (1524 mm) from processing equipment.

Exception: Portable electrostatic paint-spraying apparatus *listed* for use in Class I, Division 1, locations.

416.6.3 Fire protection. Areas used for electrostatic spray finishing with fixed equipment shall be protected with an *approved automatic fire-extinguishing system* complying with Chapter 9 and Section 416.6.3.1.

416.6.3.1 Protection for automated liquid electrostatic spray application equipment. Automated liquid electrostatic spray application equipment shall be protected by the installation of an *approved*, supervised flame detection apparatus that shall, in the event of ignition, react to the presence of flame within 0.5 second and shall accomplish all of the following:

1. Activation of a local alarm in the vicinity of the spraying operation and activation of the building alarm system, if such a system is provided.
2. Shutting down of the coating material delivery system.
3. Termination of all spray application operations.
4. Stopping of conveyors into and out of the *flammable vapor areas*.
5. Disconnection of power to the high-voltage elements in the *flammable vapor areas* and disconnection of power to the system.

416.6.4 Sources of ignition. Transformers, power packs, control apparatus and all other electrical portions of the equipment, except high-voltage grids and electrostatic atomizing heads and connections, shall be located outside the *flammable vapor areas* or shall comply with Section 416.2.1.

416.6.5 Ventilation. The *flammable vapor area* shall be ventilated in accordance with Section 416.3.5.

416.6.6 Emergency shutdown. Electrostatic apparatus shall be equipped with automatic controls operating without time delay to disconnect the power supply to the high-voltage transformer and signal the operator under any of the following conditions:

1. Stoppage of ventilating fans or failure of ventilating equipment from any cause.

2. Stoppage of the conveyor carrying articles past the high-voltage grid.

3. Occurrence of a ground or an imminent ground at any point of the high-voltage system.

4. Reduction of clearance below that required in Section 416.6.1.

416.6.7 Ventilation interlock. Hand electrostatic equipment shall be interlocked with the ventilation system for the spraying area so that the equipment cannot be operated unless the ventilating system is in operation.

416.7 Organic peroxides and dual-component coatings. Spraying operations involving the use of organic peroxides and other dual-component coatings shall be in accordance with the requirements of Section 416.2 and Sections 416.7.1 through 416.7.2.1.

416.7.1 Use of organic peroxide coatings. Spraying operations involving the use of organic peroxides and other dual-component coatings shall be conducted in *approved sprinklered spray booths* complying with Section 416.3.2.3.

416.7.2 Equipment. Spray guns and related handling equipment used with organic peroxides shall be of a type manufactured for such use.

416.7.2.1 Pressure tanks. Separate *pressure vessels* and inserts specifically for the application shall be used for the resin and for the organic peroxide, and shall not be interchanged. Organic peroxide pressure tank inserts shall be constructed of stainless steel or polyethylene.

416.8 Indoor manufacturing of reinforced plastics. Indoor manufacturing processes involving spray or hand application of reinforced plastics and using more than 5 gallons (19 L) of resin in a 24-hour period shall be in accordance with Sections 416.8.1 through 416.8.4.1.

416.8.1 Resin application equipment. Equipment used for spray application of resin shall be installed and used in accordance with Section 416.7 and Sections 416.8.2 through 416.8.4.1.

416.8.2 Fire protection. Resin application areas shall be protected by an *automatic sprinkler system*. The sprinkler system design shall be not less than that required for Ordinary Hazard Group 2, with a minimum design area of 3,000 square feet (279 m²). Where the materials or storage arrangements are required by other regulations to be provided with a higher level of sprinkler system protection, the higher level of sprinkler system protection shall be provided.

416.8.3 Sources of ignition in resin application areas. Sources of ignition in resin application areas shall comply with Section 416.2.1.

416.8.4 Ventilation. Mechanical ventilation shall be provided throughout resin application areas in accordance with Section 416.6. The ventilation rate

shall be adequate to maintain the concentration of flammable vapors in the resin application area at or below 25 percent of the LFL.

Exception: Mechanical ventilation is not required for buildings that have 75 percent of the perimeter unenclosed.

416.8.4.1 Local ventilation. Local ventilation shall be provided inside workpieces where personnel will be under or inside the workpiece.

Section 418 Organic Coatings

IBC 418.1 **418.1 Scope.** Organic coating manufacturing processes shall comply with this section, except that this section shall not apply to processes for manufacturing nonflammable or water-thinned coatings or to operations applying coating materials.

418.1.1 ~~418.1~~ **Building features.** Manufacturing of organic coatings shall be done only in buildings that do not have pits or basements.

OSSC 418.7 – 418.14.3

418.7 Fire protection systems. Fire protection systems shall be installed in accordance with Chapter 9.

418.8 Open flames. Open flames and direct-fired heating devices shall be prohibited in areas where flammable vapor air mixtures exist.

418.9 Drainage. Drainage facilities shall be provided to direct flammable and combustible liquid leakage and fire protection water to an approved location away from the building, any other structure, storage area or adjoining premises.

418.10 Alarm system. An approved fire alarm system shall be provided in accordance with Section 907.

418.11 Electrical equipment and protection. Electrical wiring and equipment shall comply with this section and shall be installed in accordance with the *Electrical Code*.

418.11.1 Hazardous locations. Where Class I liquids are exposed to the air, the design of equipment and ventilation of structures shall be such as to limit the Class I, Division 1, locations to the following:

1. Piping trenches.
2. The interior of equipment.
3. The immediate vicinity of pumps or equipment locations, such as dispensing stations, open centrifuges, plate and frame filters, opened vacuum filters, change cans and the surfaces of open equipment. The immediate vicinity shall include a zone extending from the vapor liberation point 5 feet (1524 mm) horizontally in all directions and vertically from the floor to a level 3 feet (914 mm) above the highest point of vapor liberation.

418.11.1.1 Other locations. Locations within the confines of the manufacturing room where Class I liquids are handled shall be Class I, Division 2, except locations indicated in Section 418.11.1.

418.11.1.2 Ordinary equipment. Ordinary electrical equipment, including switchgear, shall be prohibited, except where installed in a room maintained under positive pressure with respect to the hazardous area. The air or other media utilized for pressurization shall be obtained from a source that will not cause any amount or type of flammable vapor to be introduced into the room.

418.11.2 Bonding. Equipment including but not limited to tanks, machinery and piping shall be bonded and connected to a ground where an ignitable mixture is capable of being present.

418.11.3 Piping. Electrically isolated sections of metallic piping or equipment shall be grounded or bonded to the other grounded portions of the system.

418.11.4 Ground. Metal framing of buildings shall be grounded with resistance of not more than 5 ohms.

418.12 Process structures. Process structures shall be designed and constructed in accordance with this code.

418.12.1 Drainage. Drainage facilities shall be provided in accordance with Section 418.9 where topographical conditions are such that flammable and combustible liquids are capable of flowing from the organic coating manufacturing operation so as to constitute a fire hazard to other premises.

418.12.2 Explosion control. Explosion control shall be provided in areas subject to potential deflagration hazards as indicated in NFPA 35. Explosion control shall be provided in accordance with Section 919.

418.12.3 Ventilation. Enclosed structures in which Class I liquids are processed or handled shall be ventilated at a rate of not less than 1 cubic foot per minute per square foot [0.00508 m³/(s • m²)] of solid floor area. Ventilation shall be accomplished by exhaust fans that take suction at floor levels and discharge to a safe location outside the structure. Noncontaminated intake air shall be introduced in

such a manner that all portions of solid floor areas are provided with continuous uniformly distributed air movement.

418.12.4 Heating. Heating provided in hazardous areas shall be by indirect means. Ignition sources such as open flames or electrical heating elements, except as provided for in Section 418.11, shall not be permitted within the structure.

418.13 Process mills and kettles. Mills operating with close clearances that process flammable and heat-sensitive materials such as nitrocellulose shall be located in a detached building or in a noncombustible structure without other occupancies. The amount of nitrocellulose or other flammable material brought into the area shall not be more than the amount required for a batch.

418.13.1 Mixers. Mixers shall be of the enclosed type or, where of the open type, shall be provided with properly fitted covers. Where flow is by gravity, a shutoff valve shall be installed as close as practical to the mixer, and a control valve shall be provided near the end of the fill pipe.

418.13.2 Open kettles. Open kettles shall be located in an outdoor area provided with a protective roof; in a separate structure of noncombustible construction; or separated from other areas by a noncombustible wall having a fire-resistance rating of not less than 2 hours.

418.13.3 Closed kettles. Contact-heated kettles containing solvents shall be equipped with safety devices that, in case of a fire, will turn off the process heat, turn on the cooling medium and inject inert gas into the kettle.

418.13.3.1 Vaporizer location. The vaporizer section of heat-transfer systems that heat closed kettles containing solvents shall be remotely located.

418.13.4 Kettle controls. The kettle and thin-down tank shall be instrumented, controlled and interlocked so that any failure of the controls will result in a safe condition. The kettle shall be provided with a pressure-rupture disc in addition to the primary vent. The vent piping from the rupture disc shall be of minimum length and shall discharge to an *approved* location. The thin-down tank shall be adequately vented. Thinning operations shall be provided with an adequate vapor removal system.

418.14 Raw materials and finished products. The storage, handling and use of flammable and *combustible liquids* in process areas shall be in accordance with Section 444.

418.14.1 Tank storage. Tank storage for flammable and *combustible liquids* located inside structures shall be limited to storage areas at or above grade that are separated from the processing area in accordance with this code. Processing equipment containing flammable and *combustible liquids* and storage in quantities essential to the continuity of the operations shall not be prohibited in the processing area.

418.14.2 Nitrocellulose storage. Nitrocellulose storage shall be located on a detached pad or in a separate structure or a room enclosed in accordance with this code. The nitrocellulose storage area shall not be utilized for any other purpose. Electrical wiring and equipment installed in storage areas adjacent to process areas shall comply with Section 418.11.1.

418.14.3 Finished products. Finished products that are flammable or *combustible liquids* shall be stored outdoors, in a separate structure, or in a room separated from the processing area in accordance with this code. The storage of finished products shall be in tanks or *closed containers* in accordance with Section 444.

Section 419 Artificial Decorative Vegetation

IBC 419.1

419.1 Artificial decorative vegetation.

Not adopted / [Reserved](#)

Section 420 Groups I-1, R-1, R-2, R-3 and R-4

IBC 420.9 **420.9 Domestic cooking appliances.** In Group I-1 occupancies, installation of cooking appliance used in domestic cooking facilities shall comply with all of the following:

(Items 1, 3-5, and the exceptions remain unchanged)

2. Domestic cooking hoods installed and constructed in accordance with Section 505 of the ~~International~~ *Mechanical Code* shall be provided over cooktops or ranges.

~~6. A portable fire extinguisher shall be provided. Installation shall be in accordance with Section 906 and the extinguisher shall be located within a 30-foot (9144 mm) distance of travel from each domestic cooking appliance.~~

OSSC 420.12

Registered and certified family child care homes.
Section 420.12 applies to the following registered and certified family child care homes:

1. Newly constructed dwellings.
2. Newly licensed existing dwellings.
3. Additions to existing licensed dwellings.

Section 420.12 does not apply to the following registered and certified family child care homes:

1. Existing dwellings currently licensed, or previously licensed at any time.
2. Existing spaces within currently licensed dwelling.

420.12 Child care facilities within dwellings. Child care facilities located within *dwellings*, permitted by Chapter 3 to be constructed in accordance with the *Residential Code*, shall comply with either Section 420.12.1 or 420.12.2.

420.12.1 With automatic sprinkler system protection. An *automatic sprinkler system* in accordance with Section 903.3.1.3 shall be installed throughout the *fire area* of the *dwelling* where a child care facility is located.

420.12.2 Without automatic sprinkler system protection. Where an *automatic sprinkler system* is not installed throughout the *fire area* of the *dwelling* where a child care facility is located, both of the following shall be met:

1. All rooms where care is provided shall be located on a *level of exit discharge*.
2. No *exit access path* shall be located within 3 feet (914 mm) horizontally of any permanently installed cooking appliance, or be required to pass through a storage room, or through a room that can be locked to prevent egress.

Section 421 Hydrogen Fuel Gas Rooms

IBC 421.1 **421.1 General.** ~~Where required by the *International Fire Code*,~~ *Hydrogen fuel gas rooms* shall be designed and constructed in accordance with Sections 421.1 through 421.7 and 445.7

Section 422 Ambulatory Care Facilities

IBC 422.3.1 **422.3.1 Means of egress.** *Not adopted*
422.3.1 ~~**422.3.2**~~ **Refuge area.** *Renumbered*
422.3.2 ~~**422.3.3**~~ **Independent egress.** *Renumbered*

IBC 422.7 **422.7 Domestic cooking.** Installation of cooking appliances used in domestic cooking facilities shall comply with all of the following: *(Items 1 through 4 remain unchanged)*

~~5. A portable fire extinguisher shall be provided. Installation shall be in accordance with Section 906 and the extinguisher shall be located within a 30-foot (9144 mm) distance of travel from each domestic cooking appliance.~~

Section 423 Storm Shelters

IBC 423.2 –	423.2 Construction.	Not adopted
423.5.2	423.3 Occupancy classification.	Not adopted
	423.3.1 Dedicated storm shelters.	Not adopted
	423.3.2 Storm shelters within host buildings.	Not adopted
	423.4 Critical emergency operations.	Not adopted
	423.5 Group E occupancies.	Not adopted
	423.5.1 Required occupant capacity.	Not adopted
	423.5.2 Location.	Not adopted

Section 426 Combustible Dusts, Grain Processing and Storage

IBC 426

426.1 General. The provisions of Sections 426.1.1 through 426.1.7 shall apply to buildings in which materials that produce *combustible dusts* are stored or handled. Buildings that store or handle *combustible dusts* shall comply with [this code](#) ~~the applicable provisions of the *International Fire Code*~~. Where required by the ~~building official~~ *fire code official*, ~~additional industry- or material-specific codes and standards listed in Table 426.1 NFPA 652 and the applicable provisions of NFPA 61, NFPA 85, NFPA 120, NFPA 484, NFPA 654, NFPA 655 and NFPA 664~~ shall apply ~~to prevent and control dust explosions, as applicable.~~

Exceptions.

1. ~~Storage and use of consumer materials in Group B or R occupancies.~~
2. ~~Storage and use of commercially packaged materials in Group M occupancies.~~
3. ~~Materials displayed in original packaging in Group M occupancies and intended as building materials or for personal or household use.~~
4. ~~Storage of sealed containers of *combustible dust* at facilities not associated with an operation that uses, handles, or generates *combustible dust*.~~
5. ~~Materials stored or used in farm buildings or similar occupancies intended for on-premises agricultural purposes.~~

426.1.8 Dust-producing and dust-handling equipment. ~~Dust-producing equipment and dust-handling equipment, including but not limited to vacuums, dust collection systems, dryers, mixers, blenders, separators, conveyors, storage containers, silos or other similar devices, shall be listed and shall be maintained in accordance with the manufacturer's recommended standards.~~

426.1.9 Signages and markings. ~~Signages and markings shall be provided in accordance with Sections 426.1.9.1 through 426.1.9.3.~~

**TABLE 426.1
EXPLOSION PROTECTION STANDARDS**

STANDARD	SUBJECT
NFPA 61	Standard for the Prevention of Fires and Dust Explosions in Agricultural and Food Processing Facilities
NFPA 68	Standard on Explosion Protection by Deflagration Venting
NFPA 69	Standard on Explosion Prevention Systems
NFPA 77	Recommended Practice on Static Electricity
NFPA 120	Standard for Fire Prevention and Control in Coal Mines
NFPA 484	Standard for Combustible Metals
NFPA 654	Standard for Prevention of Fire and Dust Explosions from the Manufacturing, Processing and Handling of Combustible Particulate Solids
NFPA 655	Standard for the Prevention of Sulfur Fires and Explosions
NFPA 664	Standard for the Prevention of Fires and Explosions in Wood Processing and Woodworking Facilities

426.1.9.1 Deflagration vent discharge area markings. ~~Where dust collection systems and other equipment, systems or system components are provided with deflagration vents, the area within the deflagration vent's discharge area shall be marked in an *approved* manner.~~

426.1.9.2 Caution signs. ~~Signs that read as follows shall be posted near the dust-containing equipment with deflagration vents:~~

~~CAUTION: THIS EQUIPMENT CAN CONTAIN EXPLOSIVE DUST.~~

~~KEEP OUTSIDE THE MARKED AREA WHILE EQUIPMENT IS OPERATING.~~

426.1.9.3 Warning signs. ~~Where dust collection systems and other equipment, systems or system components are provided with deflagration vents, vent closures shall be clearly marked as follows:~~

~~WARNING: EXPLOSION RELIEF DEVICE. STAY CLEAR.~~

426.1.10 Dust-collection and dust-conveying systems. ~~Dust-collection and dust-conveying systems shall be in accordance with Sections 426.1.10.1 through 426.1.10.3.~~

426.1.10.1 Dust-collection systems. Dust-collection systems shall be designed to collect dust emissions from dust-producing equipment at the point of generation. Dust-collection systems shall be in accordance with Section 511 of the *Mechanical Code*.

Closed systems using *listed* equipment and designed in accordance with manufacturer’s recommendations and specifications, where cleanouts are provided in accordance with Section 426.1.10.

Heating, ventilation, and air conditioning (HVAC) systems shall not be used as the means to collect dusts from localized sources.

426.1.10.1.1 Location. Dust collectors shall be located outside of buildings.

Exceptions:

1. Dust collectors inside buildings complying with Section 511 of the *Mechanical Code*.
2. Wet-type dust collectors specifically *listed* for the type of dust conveyed shall be permitted inside buildings where in accordance with the manufacturer’s instructions and specifications.
3. Dust collectors designed to specific NFPA standards listed in Table 426.1 for the specific type of dust conveyed.

426.1.10.1.2 Minimum conveying velocities. The minimum velocities within ducts used as part of the dust collection system shall be in accordance with Table 426.1.10.1.2.

TABLE 426.1.10.1.2 MINIMUM CONVEYING VELOCITIES

TYPE OF PRODUCT	FEET PER MINUTE
Fine light dust such as cotton, lint and wood flour (100 mesh and under)	2,000
Dry dust such as fine rubber molding powder	2,500
Average dust such as sawdust, grinding dust and coal dust	3,500
Heavy dust such as metal turnings, including aluminum and magnesium powder	4,000

For SI: 1 foot per minute = 0.00508 m/s.

426.1.10.2 Plastic ducts and conveying systems. Plastic, fiberglass, other nonconductive ducts, duct liners or pipes shall not be used as part of ducts and conveying systems. Ductwork utilizing a combustible lining shall be permitted only in high-impact areas and where *approved*.

Flexible hose shall be permitted if designed and installed in accordance with the following requirements:

1. Manufactured of static dissipative construction.
2. Used only for connections and isolation purposes.
3. Limited to 18 inches (457 mm) in length.
4. Properly grounded.

426.1.10.3 Cleanouts. Openings in enclosed equipment and conveyors shall be provided to allow access to all parts of the equipment and conveyors to permit inspection, cleaning, maintenance and the effective use of portable fire extinguishers or hose streams. Cleanouts for ducts used as part of the dust-collection system shall be in accordance with the *Mechanical Code*.

426.1.11 Sources of ignition. Sources of ignition shall be controlled in accordance with Sections 426.1.11.1 through 426.1.11.

426.1.11.1 Classified electrical. Classified electrical shall be in accordance with the *Electrical Code*.

426.1.11.2 Static electricity. Bonding and grounding is required to minimize accumulation of static electric charge in the following locations:

1. Dust-producing equipment.
2. Dust-collection system.
3. Pneumatic dust-conveying systems conveying *combustible dust* from one location to another, *combustible dust* conveyors, piping and conductive components. Conveying systems include transport modes such as railcars, hopper cars, boxcars, tank cars and trucks into which or from which commodities or products are pneumatically conveyed.
4. Conveying systems using metallic piping.

426.1.12 Dust explosion screening tests.

426.1.12.1 Combustibility and explosivity tests. Where combustibility or explosivity screening tests are required to analyze the *combustible dust* as part of compliance with Sections 104.8 and 414.1.3, they shall be in accordance with Section 5.4 of NFPA 652.

426.1.12.2 Samples. Representative samples for the screening test shall be obtained in accordance with Section 5.5 of NFPA 652.

426.1.13 Dust Hazard Analysis. If a dust hazard analysis (DHA) is required by the *building official* for new facilities, it shall be in accordance with NFPA 652.

Section 427 Medical Gas Systems

IBC 427.2 **427.2 Interior supply location.** Medical gases shall be located in areas dedicated to the storage of such gases without other storage or uses. Where containers of medical gases in quantities greater than the permitted amount set forth in Table 427.2 are located inside the buildings, they shall be located in a 1-hour exterior room, 1-hour interior room or a *gas cabinet* in accordance with Section 427.2.1, 427.2.2 or 427.2.3, respectively. Rooms or areas where medical gases are stored or used in quantities exceeding the maximum allowable quantity per control area as set forth in Table 307.1(1) and Table 307.1(2) shall be in accordance with Group H occupancies.

TABLE 427.2
PERMITTED AMOUNTS FOR COMPRESSED GASES

TYPE OF GAS	AMOUNT (cubic feet at NTP)
Carbon dioxide	875 (100 lbs.)
Corrosive	200
Flammable (except cryogenic fluids and liquefied petroleum gases)	200
Highly toxic	Any amount
Inert and simple asphyxiant	6,000
Oxidizing (including oxygen)	504
Pyrophoric	Any amount
Toxic	Any amount

For SI: 1 cubic foot = 0.02832 m³.

Section 428 Higher Education Laboratories

OSSC 428.5 **428.5 Container size.** The maximum container size for all hazardous materials shall be 5.3 gallons (20 L) for liquids, 50 pounds (22.7 kg) for solids, 100 cubic feet (2.83 m³) for health-hazard gases per Table 307.1(2) and 500 cubic feet (14.15 m³) for all other gases in accordance with Table 307.1(1).

Exception: Hazardous waste collection containers, for other than Class I flammable liquids and Class II combustible liquids, are permitted to exceed 5.3 gallons (20 L) where *approved*.

OSSC 428.6 **428.6 Density.** Quantities of Class I flammable liquids in storage and use shall not exceed 8 gallons (30 L) per 100 square feet (9.29 m²) of floor area. Densities shall be reduced by 25 percent on the fourth through sixth floors of the building, and by 50 percent above the sixth floor. Regardless of the density, the maximum allowable quantity per control area or laboratory suite in accordance with this section, shall not be exceeded.

Exception: Designated hazardous waste collection areas or rooms within a laboratory suite or control area are not limited, but such materials shall not exceed the maximum allowable quantity per laboratory suite or control area.

Section 429 Stationary Fuel Cell Power Systems**OSSC 429**

429.1 General. *Stationary fuel cell power systems* shall comply with this section.

429.2 Equipment. *Stationary fuel cell power systems* shall comply with the following:

1. *Prepackaged fuel cell power systems* shall be listed and labeled in accordance with CSA FC 1.
2. The modules and components in a *preengineered fuel cell power system* shall be listed and labeled in accordance with CSA FC 1 and interconnected to complete the assembly of the system at the job site in accordance with the manufacturer's instructions and the module and component listings.

3. *Field-fabricated fuel cell power systems* shall be *approved* based on a review of a technical report, prepared without charge to the jurisdiction, by a qualified engineer, specialist, laboratory or safety specialty organization acceptable to the *building official*. The report shall be prepared by and bear the stamp of a registered design professional and shall include:

- 3.1. A fire risk evaluation.
- 3.2. An evaluation demonstrating that modules and components in the fuel cell power system comply with applicable requirements in CSA FC 1.

3.3. Documentation of the fuel cell power system's compliance with applicable NFPA 2 and NFPA 853 construction requirements.

429.3 Installation. *Stationary fuel cell power systems* shall be installed and maintained in accordance with the *Electrical Code* and NFPA 853, the manufacturer's instructions, and the listing. *Stationary fuel cell power systems* fueled by hydrogen shall be installed in accordance with NFPA 2 and the *Electrical Code*, the manufacturer's installation instructions and the listing.

429.4 Residential use. *Stationary fuel cell power systems* shall not be installed in Group R-3 and R-4 buildings, or dwelling units associated with Group R-2 buildings unless they are specifically listed for residential use.

429.5 Indoor installations. *Stationary fuel cell power systems* installed in indoor locations shall comply with Sections 429.5.1 and 429.5.2. For purposes of this section, an indoor location includes a roof and 50 percent or greater enclosing walls.

429.5.1 Listed. *Stationary fuel cell power systems* installed indoors shall be specifically listed and labeled for indoor use.

429.5.2 Separation. Rooms containing *stationary fuel cell power systems* shall be separated from the following occupancies by fire barriers or horizontal assemblies, or both, constructed in accordance with this code.

1. Group B, F, M, S and U occupancies by 1-hour fire-resistance-rated construction.
2. Group A, E, I and R occupancies by 2-hour fire-resistance-rated construction.

Exception: *Stationary fuel cell power systems* with an aggregate rating less than 50 kW shall not be required to be separated from other occupancies provided that the systems comply with Section 9.3 of NFPA 853.

429.6 Vehicle impact protection. Where *stationary fuel cell power systems* are subject to impact by a motor vehicle, including forklifts, vehicle impact protection shall be provided in accordance with Section 912.4.4.

429.7 Fuel supply. The design, location and installation of the fuel supply for *stationary fuel cell power systems* shall comply with Appendix C of the *Mechanical Code*, based on the particular fuel being supplied to the system.

429.8 Manual shutoff. Access to a manual shutoff valve shall be provided for the fuel piping within 6 feet (1829 mm) of any fuel storage tank serving the fuel cell and within 6 feet (1829 mm) of the power system. If the fuel tank and the *stationary fuel cell power system* are less than 12 feet (3658 mm) apart, a single shutoff valve shall be permitted. If the *stationary fuel cell power system* is located indoors, the shutoff valve shall be located outside the room in which the system is installed, unless otherwise approved by the *building official*.

429.9 Ventilation and exhaust. Ventilation and exhaust for *stationary fuel cell power systems* shall be provided in accordance with NFPA 853.

429.10 Fire protection. Fire protection systems for *stationary fuel cell power system* installations shall be provided in accordance with NFPA 853.

429.11 Gas detection systems. *Stationary fuel cell power systems* shall be provided with a gas detection system. Detection shall be provided in approved locations in the fuel cell power system enclosure, the exhaust system or the room that encloses the fuel cell power system. The system shall be designed to activate at a flammable gas concentration of not more than 25 percent of the LFL.

429.11.1 System activation. The activation of the gas detection system shall automatically:

1. Close valves between the gas supply and the fuel cell power system.
2. Shut down the fuel cell power system.
3. Initiate local audible and visible alarms in approved locations.

Section 430 Electrical Energy Storage Systems (ESS)

OSSC 430

430.1 General. The provisions in this section are applicable to stationary electrical energy storage systems (ESS).

Exception: ESS in Group R-3 and R-4 occupancies shall comply with Section 430.11.

430.2 Scope. ESS having capacities exceeding the values shown in Table 430.2 shall comply with this section and the *Electrical Code*.

430.3 Construction documents. The following information shall be provided with the *permit* application:

1. Location and layout diagram of the room in which the ESS is to be installed.
2. Details on hourly fire-resistance ratings of assemblies enclosing the ESS.
3. The quantities and types of ESS to be installed.
4. Manufacturer's specifications, ratings and listings of each ESS.
5. Location and content of required signage.
6. Details on fire suppression, smoke or fire detection, thermal management, ventilation, exhaust and deflagration venting systems, if provided.
7. Support arrangement associated with the installation, including any required seismic restraint.

**TABLE 430.2
ENERGY STORAGE SYSTEM (ESS) THRESHOLD
QUANTITIES**

BATTERY TECHNOLOGY	ENERGY CAPACITY ^a
Capacitor ESS	3 kWh
Flow batteries ^b	20 kWh
Lead-acid, all types	70 kWh
Lithium-ion batteries	20 kWh
Nickel metal hydride (Ni-MH)	70 kWh
Nickel cadmium (Ni-Cd)	70 kWh
Other battery technologies	10 kWh
Other electrochemical ESS technologies	3 kWh

For SI: 1 kilowatt hour = 3.6 megajoules, 1 gallon = 3.785 L.

a. Energy capacity is the total energy capable of being stored (nameplate rating), not the usable energy rating. For units rated in amp-hours, kWh shall equal rated voltage times amp hour rating divided by 1,000.

b. Shall include vanadium, zinc-bromine, polysulfide-bromide and other flowing electrolyte-type technologies.

c. Fifty gallons of lead-acid battery electrolyte shall be considered equivalent to 70 kWh.

430.4 Hazard mitigation analysis. A failure modes and effects analysis (FMEA) or other *approved* hazard mitigation analysis shall be provided and prepared without charge to the jurisdiction by a qualified engineer, specialist, laboratory or safety specialty organization acceptable to the *building official*. The analysis shall be

prepared by and bear the stamp of a *registered design professional*. The analysis shall be provided under any of the following conditions:

1. Where ESS technologies not specifically identified in Table 430.2 are provided.
2. More than one ESS technology is provided in a room or enclosed area where there is a potential for adverse interaction between technologies.
3. Where allowed as a basis for increasing maximum allowable quantities in accordance with Section 430.7.2.

430.4.1 Fault condition. The hazard mitigation analysis shall evaluate the consequences of the following failure modes. Only single-failure modes shall be considered.

1. Thermal runaway condition in a ESS rack, module or unit.
2. Failure of any battery (energy) management system.
3. Failure of any required ventilation or exhaust system.
4. Voltage surges on the primary electric supply.
5. Short circuits on the load side of the ESS.
6. Failure of the smoke detection, fire detection, fire suppression or gas detection system.
7. Required spill neutralization not being provided or failure of the *secondary containment system*.

430.4.2 Analysis approval. The *building official* is authorized to approve the hazardous mitigation analysis provided that the consequences of the hazard mitigation analysis demonstrate:

1. Fires will be contained within unoccupied ESS rooms or areas for the minimum duration of the fire-resistance-rated separations identified in Table 509.
2. Fires in occupied work centers will be detected in time to allow occupants within the room or area to safely evacuate.
3. Toxic and highly toxic gases released during fires will not reach concentrations in excess of the IDLH level in the building or adjacent *means of egress* routes during the time deemed necessary to evacuate from any affected area.
4. Flammable gases released from ESS during charging, discharging and normal operation shall not exceed 25 percent of their lower flammable limit (LFL).

5. Flammable gases released from ESS during fire, overcharging and other abnormal conditions will be controlled through the use of ventilation of the gases, preventing accumulation, or by *deflagration* venting.

430.4.3 Additional protection measures. Construction, equipment and systems that are required for the ESS to comply with the hazardous mitigation analysis, including but not limited to those specifically described in Section 430.4, shall be installed and tested in accordance with nationally recognized standards and specified design parameters.

430.5 Large-scale fire test. Where required elsewhere in this code, large-scale fire testing shall be conducted on a representative ESS in accordance with UL 9540A. The testing shall be conducted or witnessed and reported by an approved testing laboratory and show that a fire involving one ESS will not propagate to an adjacent ESS, and where installed within buildings, enclosed areas and walk-in units will be contained within the room, enclosed area or walk-in unit for a duration equal to the *fire-resistance rating* of the room separation specified in Section 430.9.4. The test report shall be provided to the *building official* for review and approval.

430.6 General installation requirements.

430.6.1 Fire resistance-rated separations. Rooms and other indoor areas containing ESS shall be separated from other areas of the building in accordance with Section 509.1. ESS shall be permitted to be in the same room with the equipment they support.

430.6.2 Seismic and structural design. Stationary ESS shall comply with the seismic design requirements in Chapter 16 and shall not exceed the floor loading limitation of the building.

430.6.3 Vehicle impact protection. Where ESS are subject to impact by a motor vehicle, including fork lifts, vehicle impact protection shall be provided in accordance with Section 912.4.4.

430.6.4 Toxic and highly toxic gases. ESS that have the potential to release toxic and highly toxic gas during charging, discharging and normal use conditions shall be provided with a hazardous exhaust system in accordance with Section 502.8 of the *Mechanical Code*.

430.6.5 Signage. *Approved* signs shall be provided on or adjacent to all entry doors for ESS rooms or areas and on enclosures of ESS cabinets and walk-in units located outdoors, on rooftops or in open parking garages. Signs designed to meet both the requirements of this section and the *Electrical Code* shall be permitted. The signage shall include the following or equivalent:

1. "ENERGY STORAGE SYSTEM," "BATTERY STORAGE SYSTEM," "CAPACITOR ENERGY STORAGE SYSTEM" or the equivalent.

2. The identification of the electrochemical ESS technology present.
3. "ENERGIZED ELECTRICAL CIRCUITS."
4. Where water-reactive electrochemical ESS are present, the signage shall include "APPLY NO WATER."

430.7 Electrochemical ESS protection. The protection of electrochemical ESS shall be in accordance with Sections 430.7.1 through 430.7.5.1 where required by Sections 430.9 through 430.10.6.

430.7.1 Size and separation. Electrochemical ESS shall be segregated into groups not exceeding 50 kWh (180 megajoules). Each group shall be separated not less than 3 feet (914 mm) from other groups and from walls in the storage room or area. The storage arrangements shall comply with Chapter 10.

1. Lead acid and nickel-cadmium battery systems in facilities under the exclusive control of communications utilities and operating at less than 50 VAC and 60 VDC in accordance with NFPA 76.
2. The *building official* is authorized to approve larger capacities or smaller separation distances based on large-scale fire testing complying with Section 430.5.

430.7.2 Maximum allowable quantities. *Fire areas* within rooms, areas and walk-in units containing electrochemical ESS shall not exceed the maximum allowable quantities in Table 430.5.

Exceptions:

1. Where approved by the *building official*, rooms, areas and walk-in units containing electrochemical ESS that exceed the amounts in Table 430.7 shall be permitted based on a hazardous mitigation analysis in accordance with Section 430.4 and large-scale fire testing complying with Section 430.5.
2. Lead-acid and nickel-cadmium battery systems installed in facilities under the exclusive control of communications utilities, and operating at less than 50 VAC and 60 VDC in accordance with NFPA 76.
3. Dedicated-use buildings in compliance with Section 430.9.1.

430.7.3 Elevation. Electrochemical ESS shall not be located in the following areas:

1. Where the floor is located more than 75 feet (22 860 mm) above the lowest level of fire department vehicle access.
2. Where the floor is located below the lowest level of exit discharge.

Exceptions:

1. Lead-acid and nickel-cadmium battery systems less than 50 VAC and 60 VDC installed in facilities under the exclusive control of

communications utilities in accordance with NFPA 76.

2. Where *approved*, installations shall be permitted in underground vaults complying with *Electrical Code*.
3. Where *approved*, installations shall be permitted on higher and lower floors.

430.7.4 Fire detection. An approved automatic smoke detection system or radiant energy-sensing fire detection system complying with Section 907.2 shall be installed in rooms, indoor areas and walk-in units containing electrochemical ESS. An approved radiant energy-sensing fire detection system shall be installed to protect open parking garage and rooftop installations. Alarm signals from detection systems shall be transmitted to a central station, proprietary or remote station service in accordance with NFPA 72, or where approved to a constantly attended location.

430.7.4.1 System status. Where required by the *building official*, visible annunciation shall be provided on cabinet exteriors or in other approved locations to indicate that potentially hazardous conditions associated with the ESS exist.

430.7.5 Fire suppression systems. Rooms and areas within buildings and walk-in units containing electrochemical ESS shall be protected by an automatic fire suppression system designed and installed in accordance with one of the following:

1. An automatic sprinkler system designed and installed in accordance with Section 903.3.1.1 with a minimum density of 0.3 gpm/ft² (1.14 L/min) based on the *fire area* or 2,500 square-foot (232 m²) design area, whichever is smaller.
2. Where *approved*, an automatic sprinkler system designed and installed in accordance with Section 903.3.1.1 with a sprinkler hazard classification based on large-scale fire testing complying with Section 430.5.
3. The following alternative automatic fire-extinguishing systems designed and installed in accordance with Section 904, provided that the installation is *approved* by the *building official* based on large-scale fire testing complying with Section 430.5:
 - 3.1. NFPA 12, Standard on Carbon Dioxide Extinguishing Systems.
 - 3.2. NFPA 15, Standard for Water Spray Fixed Systems for Fire Protection.
 - 3.3. NFPA 750, Standard on Water Mist Fire Protection Systems.
 - 3.4. NFPA 2001, Standard on Clean Agent Fire-Extinguishing Systems.
 - 3.5. NFPA 2010, Standard for Fixed Aerosol Fire-Extinguishing Systems.

Fire suppression systems for lead-acid and nickel-cadmium battery systems at facilities under the exclusive control of communications utilities that operate at less than 50 VAC and 60 VDC shall be provided where required by NFPA 76.

430.7.5.1 Water-reactive systems. Electrochemical ESS that utilize water-reactive materials shall be protected by an approved alternative automatic fire-extinguishing system in accordance with Section 904, where the installation is *approved* based on large-scale fire testing complying with Section 430.5.

**TABLE 430.7
MAXIMUM ALLOWABLE BATTERY QUANTITIES**

BATTERY TECHNOLOGY	MAXIMUM ALLOWABLE QUANTITIES ^a	GROUP H OCCUPANCY
Flow batteries ^b	600 kWh	Group H-2
Lead acid, all types	Unlimited	Not Applicable
Lithium, all types	600 kWh	Group H-2
Nickel-cadmium (Ni-Cd)	Unlimited	Not Applicable
Sodium, all types	600 kWh	Group H-2
Other battery technologies	200 kWh	Group H-2 ^c

For SI: 1 kilowatt hour = 3.6 megajoules.

- a. For batteries rated in amp hours, kilowatt hours (kWh) shall equal rated battery voltage times the amp-hour rating divided by 1,000.
- b. Shall include vanadium, zinc-bromine, polysulfide-bromide, and other flowing electrolyte-type technologies.
- c. Shall be a Group H-4 occupancy if the *building official* determines that a fire or thermal runaway involving the battery technology does not represent a significant fire hazard.

430.7.6 Maximum enclosure size. Outdoor walk-in units housing ESS shall not exceed 53 feet by 8 feet by 9.5 feet high (16 154 mm × 2438 mm × 2896 mm), not including bolt-on HVAC and related equipment, as *approved*. Outdoor walk-in units exceeding these limitations shall be considered indoor installations and comply with the requirements in Section 430.9.

430.7.7 Means of egress separation. ESS located outdoors and in open parking garages shall be separated from any means of egress as required by the *building official* to ensure safe egress under fire conditions, but in no case less than 10 feet (3048 mm).

Exception: The *building official* is authorized to approve a reduced separation distance if large-scale fire testing complying with Section 430.5 is provided that shows that a fire involving the ESS will not adversely impact occupant egress.

430.8 Electrochemical ESS technology-specific protection. Electrochemical ESS installations shall comply with the requirements of this section in accordance with the applicable requirements of Table 430.8.

430.8.1 Exhaust ventilation. Where required by Table 430.8 or elsewhere in this code, exhaust ventilation of rooms, areas and walk-in units containing electrochemical ESS shall be provided in accordance with the *Mechanical Code* and Section 430.8.1.1 or 430.8.1.2.

430.8.1.1 Ventilation based on LFL. The exhaust ventilation system shall be designed to limit the maximum concentration of flammable gas to 25 percent of the lower flammable limit (LFL) of the total volume of the room, area or walk-in unit during the worst-case event of simultaneous charging of batteries at the maximum charge rate, in accordance with nationally recognized standards.

430.8.1.2 Ventilation based on exhaust rate. Mechanical exhaust ventilation shall be provided at a rate of not less than 1 ft³/min/ft² (5.1 L/sec/m²) of floor area of the room, area or walk-in unit. The ventilation shall be either continuous or shall be activated by a gas detection system in accordance with Section 430.8.1.2.4.

430.8.1.2.1 Standby power. Mechanical exhaust ventilation shall be provided with standby power capable of powering the required load for a duration of not less than 2 hours.

430.8.1.2.2 Installation instructions. Required mechanical exhaust ventilation systems shall be installed in accordance with the manufacturer's installation instructions and the *Mechanical Code*.

430.8.1.2.3 Supervision. Required mechanical ventilation systems shall be supervised by an *approved* central station, proprietary or remote station service in accordance with NFPA 72, or shall initiate an audible and visible signal at an *approved* constantly attended on-site location.

430.8.1.2.4 Gas detection system. Where required by Section 430.8.1.2, rooms, areas and walk-in units containing ESS shall be protected by an *approved* continuous gas detection system that complies with Section 916 and with the following:

1. The gas detection system shall be designed to activate the mechanical ventilation system when the level of flammable gas in the room, area or walk-in unit exceeds 25 percent of the LFL.
2. The mechanical ventilation system shall remain on until the flammable gas detected is less than 25 percent of the LFL.
3. The gas detection system shall be provided with standby power capable of powering the required load for a duration of not less than 2 hours.

4. Failure of the gas detection system shall announce a trouble signal at an approved central station, proprietary or remote station service in accordance with NFPA 72, or shall initiate an audible and visible trouble signal at an approved constantly attended on-site location.

430.8.2 Spill control and neutralization. Where required by Table 430.8 or elsewhere in this code, areas containing free-flowing liquid electrolyte or hazardous materials shall be provided with spill control and neutralization in accordance with this section.

430.8.2.1 Spill control. Spill control shall be provided to prevent the flow of liquid electrolyte or hazardous materials to adjoining rooms or areas. The method shall be capable of containing a spill from the single largest battery or vessel.

430.8.2.2 Neutralization. An *approved* method that is capable of neutralizing spilled liquid electrolyte from the largest battery or vessel to a pH between 5.0 and 9.0 shall be provided.

430.8.2.3 Communications utilities. The requirements of Section 430.8.2 shall apply only when the aggregate capacity of multiple vessels exceeds 1,000 gallons (3785 L) for lead-acid and nickel-cadmium battery systems operating at less than 50 VAC and 60 VDC that are located at facilities under the exclusive control of communications utilities, and those facilities comply with NFPA 76 in addition to applicable requirements of this code.

430.8.3 Explosion control. Where required by Table 430.8 or elsewhere in this code, explosion control complying with Section 911 shall be provided for rooms, areas or walk-in units containing electrochemical ESS technologies.

Exceptions:

1. Where *approved*, explosion control is permitted to be waived based on large-scale fire testing complying with Section 430.5 that demonstrates that flammable gases are not liberated from electrochemical ESS cells or modules where tested in accordance with UL 9540A.
2. Where *approved*, explosion control is permitted to be waived by the *building official* based on documentation that demonstrates that the electrochemical ESS technology to be used does not have the potential to release flammable gas concentrations in excess of 25 percent of the LFL anywhere in the room, area, walk-in unit or structure under thermal runaway or other fault conditions.

430.8.4 Safety caps. Where required by Table 430.8 or elsewhere in this code, vented batteries and other ESS shall be provided with flame-arresting safety caps.

**TABLE 430.8
ELECTROCHEMICAL ESS TECHNOLOGY-SPECIFIC REQUIREMENTS**

COMPLIANCE REQUIRED ^b		BATTERY TECHNOLOGY				OTHER ESS AND BATTERY TECHNOLOGIES ^b	CAPACITOR ESS ^b
Feature	Section	Lead-acid	Ni-Cd and Ni-MH	Lithium-ion	Flow		
Exhaust ventilation	430.8.1	Yes	Yes	No	Yes	Yes	Yes
Explosion control	430.8.3	Yes ^a	Yes ^a	Yes	No	Yes	Yes
Safety caps	430.8.4	Yes	Yes	No	No	Yes	Yes
Spill control and neutralization	430.8.2	Yes ^c	Yes ^c	No	Yes	Yes	Yes
Thermal runaway	430.8.5	Yes ^d	Yes	Yes ^e	No	Yes ^e	Yes

- a. Not required for lead-acid and nickel-cadmium batteries at facilities under the exclusive control of communications utilities that comply with NFPA 76 and operate at less than 50 VAC and 60 VDC.
- b. Protection shall be provided unless documentation acceptable to the building official that provides justification why the protection is not necessary based on the technology used.
- c. Applicable to vented-type (i.e., flooded) nickel-cadmium and lead-acid batteries.
- d. Not required for vented-type (i.e., flooded) lead-acid batteries.
- e. The thermal runaway protection is permitted to be part of a battery management system that has been evaluated with the battery as part of the evaluation to UL 1973.

430.8.5 Thermal runaway. Where required by Table 430.8 or elsewhere in this code, batteries and other ESS shall be provided with a listed device or other approved method to prevent, detect and minimize the impact of thermal runaway.

430.9 Indoor installations. Indoor ESS installations shall be in accordance with Sections 430.9.1 through 430.9.4.

430.9.1 Dedicated-use buildings. For the purpose of Table 430.9, dedicated-use ESS buildings shall be classified as Group F-1 occupancies and comply with all the following:

1. The building shall only be used for ESS, electrical energy generation and other electrical grid-related operations.
2. No other occupancy types shall be permitted in the building.

430.9.2 Nondedicated-use buildings. For the purpose of Table 430.9, nondedicated-use buildings include all buildings that contain ESS and do not comply with Section 430.9.1 dedicated-use building requirements.

430.9.3 Dwelling units and sleeping units. ESS shall not be installed in sleeping units or in habitable spaces of dwelling units.

430.9.4 Fire-resistance-rated separations. Rooms and areas containing ESS shall include fire-resistance-rated separations as follows:

1. In dedicated-use buildings, rooms and areas containing ESS shall be separated from areas in which administrative and support personnel are located.
2. In nondedicated-use buildings, rooms and areas containing ESS shall be separated from other areas in the building.

Separation shall be provided by 2-hour fire barriers constructed in accordance with Section 707 and 2-hour horizontal assemblies constructed in accordance with Section 711, as appropriate.

430.10 Special installations. Rooftop and open parking garage ESS installations shall comply with Sections 430.10.1 through 430.10.6.

430.10.1 Rooftop installations. For the purpose of Table 430.10, rooftop ESS installations are those located on the roofs of buildings.

430.10.2 Open parking garage installations. For the purpose of Table 430.10, open parking garage ESS installations are those located in a structure or portion of a structure that complies with Section 406.5.

430.10.3 Clearance to exposures. ESS located on roof-tops and in open parking garages shall be separated by a minimum of 10 feet (3048 mm) from the following exposures:

1. Buildings, except the building on which rooftop ESS is mounted.
2. Any portion of the building on which a rooftop system is mounted that is elevated above the roof-top on which the system is installed.
3. Lot lines.
4. Public ways.
5. Locations where motor vehicles can be parked.
6. Hazardous materials.
7. Other exposure hazards.

Exceptions:

1. Clearances are permitted to be reduced to 3 feet (914 mm) where a 1-hour free-standing fire barrier suitable for exterior use and extending 5 feet (1524 mm) above and 5 feet (1524 mm) beyond the physical boundary of the ESS installation is provided to protect the exposure.
2. Clearances are permitted to be reduced to 3 feet (914 mm) where a weatherproof enclosure constructed of noncombustible materials is provided over the ESS, and it has been demonstrated that a fire within the enclosure will not ignite combustible materials outside the enclosure based on large-scale fire testing complying with Section 430.5.

**TABLE 430.9
INDOOR ESS INSTALLATIONS**

COMPLIANCE REQUIRED		DEDICATED-USE BUILDINGS ^a	NONDEDICATED-USE BUILDINGS ^b
Feature	Section		
Dwelling units and sleeping units	430.9.3	NA	Yes
Elevation	430.7.3	Yes	Yes
Fire suppression systems	430.7.5	Yes ^c	Yes
Fire-resistance-rated separations	430.9.4	Yes	Yes
General installation requirements	430.6	Yes	Yes
Maximum allowable quantities	430.7.2	No	Yes
Size and separation	430.7.1	Yes	Yes
Smoke and automatic fire detection ^e	430.7.4	Yes ^d	Yes
Technology specific protection	430.8	Yes	Yes

NA = Not Allowed.

- a. See Section 430.9.1.
- b. See Section 430.9.2.
- c. Where approved by the building official, fire suppression systems are permitted to be omitted in dedicated-use buildings located more than 100 feet (30.5 m) from buildings, lot lines, public ways, stored combustible materials, hazardous materials, high-piled stock and other exposure hazards.
- d. Where approved by the building official, alarm signals are not required to be transmitted to a central station, proprietary or remote station service in accordance with NFPA 72, or a constantly attended location where local fire alarm annunciation is provided and trained personnel are always present.
- e. Lead-acid and nickel-cadmium battery systems installed in Group U buildings and structures less than 1,500 square feet (139 m²) under the exclusive control of communications utilities, and operating at less than 50 VAC and 60 VDC in accordance with NFPA 76, are not required to have an approved automatic smoke or fire detection system.

**TABLE 430.10
SPECIAL ESS INSTALLATIONS**

COMPLIANCE REQUIRED		ROOFTOPS ^a	OPEN PARKING GARAGES ^b
Feature	Section		
All ESS installations	430.6	Yes	Yes
Clearance to exposures	430.10.3	Yes	Yes
Fire suppression systems	430.10.4	Yes	Yes
Maximum allowable quantities	430.7.2	Yes	Yes
Maximum enclosure size	430.7.6	Yes	Yes
Means of egress separation	430.7.7	Yes	Yes
Open parking garage installations	430.10.6	No	Yes
Rooftop installations	430.10.5	Yes	No
Size and separation	430.7.1	Yes	Yes
Smoke and automatic fire detection	430.7.4	Yes	Yes
Technology-specific protection	430.8	Yes	Yes

- a. See Section 430.10.1.
- b. See Section 430.10.2.

430.10.4 Fire suppression systems. ESS located in walk-in-units on rooftops or in walk-in units in open parking garages shall be provided with automatic fire suppression systems within the ESS enclosure in accordance with Section 430.7.5. Areas containing ESS other than walk-in-units in open parking structures on levels not open above to the sky shall be provided with an automatic fire suppression system complying with Section 430.7.5.

Exception: A fire suppression system is not required in open parking garages if large-scale fire testing complying with Section 430.5 is provided that shows that a fire will not impact the exposures in Section 430.10.3.

430.10.5 Rooftop installations. ESS and associated equipment that are located on rooftops and not enclosed by building construction shall comply with the following:

1. Stairway access to the roof for emergency response and fire department personnel shall be provided either through a bulkhead from the interior of the building or a stairway on the exterior of the building.
2. Service walkways at least 5 feet (1524 mm) in width shall be provided for service and emergency personnel from the point of access to the roof to the system.
3. ESS and associated equipment shall be located from the edge of the roof a distance equal to at least the height of the system, equipment or component but not less than 5 feet (1524 mm).

4. The roofing materials under and within 5 feet (1524 mm) horizontally from an ESS or associated equipment shall be noncombustible or shall have a Class A rating when tested in accordance with ASTM E108 or UL 790.
5. A Class I standpipe outlet shall be installed at an *approved* location on the roof level of the building or in the stairway bulkhead at the top level.
6. The ESS shall be the minimum of 10 feet (3048mm) from the fire service access point on the rooftop.

430.10.6 Open parking garages. ESS and associated equipment that are located in open parking garages shall comply with all of the following:

1. ESS shall not be located within 50 feet (15240mm) of air inlets for building HVAC systems.
Exception: This distance shall be permitted to be reduced to 25 feet (7620 mm) if the automatic fire alarm system monitoring the radiant-energy sensing detectors de-energizes the ventilation system connected to the air intakes upon detection of fire.
2. ESS shall not be located within 25 feet (7620 mm) of exits leading from the attached building where located on a covered level of the parking structure not directly open to the sky above.
3. An approved fence with a locked gate or other approved barrier shall be provided to keep the general public at least 5 feet (1524 mm) from the outer enclosure of the ESS.

430.11 ESS in Group R-3 and R-4 occupancies. ESS in Group R-3 and R-4 occupancies shall be installed in accordance with Sections 430.11.1 through 430.11.8.

430.11.1 Equipment listings. ESS shall be listed and labeled in accordance with UL 9540. ESS listed and labeled solely for utility or commercial use shall not be used for residential applications.

Exceptions:

1. Where approved, repurposed unlisted battery systems from electric vehicles are allowed to be installed outdoors or in detached dedicated cabinets located not less than 5 feet (1524 mm) from exterior walls, property lines and public ways.
2. ESS less than 1 kWh (3.6 megajoules).

430.15.2 Installation. ESS shall be installed in accordance with the manufacturer's instructions and their listing.

430.11.2.1 Spacing. Individual units shall be separated from each other by at least 3 feet (914 mm) of spacing unless smaller separation distances are documented to be adequate based on large-scale fire testing complying with Section 430.5.

430.11.3 Location. ESS shall be installed only in the following locations:

1. Detached garages and detached accessory structures.
2. Attached garages separated from the *dwelling unit* living space and *sleeping units* in accordance with Section 406.3.2.
3. Utility closets and storage or utility spaces within *dwelling units* and *sleeping units*.

430.11.4 Energy ratings. Individual ESS units shall have a maximum rating of 20 kWh. The aggregate rating structure shall not exceed:

1. 40 kWh within utility closets and storage or utility spaces.
2. 80 kWh in attached or detached garages and detached accessory structures.
3. 80 kWh on exterior walls.
4. 80 kWh outdoors on the ground.

430.11.5 Fire detection. Rooms and areas within *dwelling units*, *sleeping units* and attached garages in which ESS are installed shall be protected by *smoke alarms* in accordance with Section 907.2.11. A heat detector listed and interconnected to the *smoke alarms* shall be installed in locations within *dwelling units*, *sleeping units* and attached garages where *smoke alarms* cannot be installed based on their listing.

430.11.6 Protection from impact. ESS installed in a location subject to vehicle damage shall be provided with impact protection in accordance with Section 430.11.6.2. Also See Figure 430.11.6.2 for examples of typical vehicle paths and acceptable methods of protection.

430.11.6.1 Garage. Where an ESS is installed in the normal driving path of vehicle travel within a garage, impact protection shall be provided in accordance with Section 430.11.6.2.

The normal driving path is a space between the garage vehicle opening and the interior face of the back wall to a height of 48 inches (1219 mm) above the finished floor. The width of the normal driving path shall be equal to the width of the garage door opening.

Impact protection shall also be provided for an ESS installed at either of the following locations:

1. On the interior face of the back wall and located within 36 inches (914 mm) to the left or to the right of the normal driving path.
2. On the interior face of a side wall and located within 24 inches (610 mm) from the back wall and 36 inches (914 mm) of the normal driving path.

Exception: Where the clear height of the vehicle garage opening is 7 feet 6 inches (2286 mm) or less, ESS installed not less than 36 inches (914 mm) above the finished floor are not subject to vehicle impact protection requirements.

430.11.6.2 Impact protection options. Where required by Section 430.11.6 or 430.11.6.1, impact protection for ESS shall comply with one of the following:

1. Bollards constructed in accordance with one of the following:
 - 1.1. Minimum 48 inches (1219 mm) in length by 3 inches (76 mm) in diameter schedule 80 steel pipe embedded in a concrete pier not less than 12 inches (304 mm) deep and 6 inches (152 mm) in diameter, with at least 36 inches (914 mm) of pipe exposed, filled with concrete, and spaced at a maximum interval of 60 inches (1524 mm). Each bollard shall be located not less than 6 inches (152 mm) from an ESS.
 - 1.2. Minimum 36 inches (914 mm) in height by 3 inches (76 mm) in diameter schedule 80 steel pipe fully welded to a minimum 8 inches (203 mm) by 8 inches (203 mm) by 1/4-inch (6.4 mm) thick steel plate and bolted to a concrete floor by means of 4 1/2 inch (113 mm) concrete anchors with 3-inch (76 mm) minimum embedment. Spacing shall be not more than 60 inches (1524 mm), and each bollard shall be located not less than 6 inches (152 mm) from the ESS.
 - 1.3. Pre-manufactured steel pipe bollards shall be filled with concrete and anchored in accordance with the *manufacturer's installation instructions*, with spacing not greater than a 60 inches (1524 mm). Each bollard shall be located not less than 6 inches (152mm) from the ESS.

2. Wheel barriers constructed in accordance with one of the following:

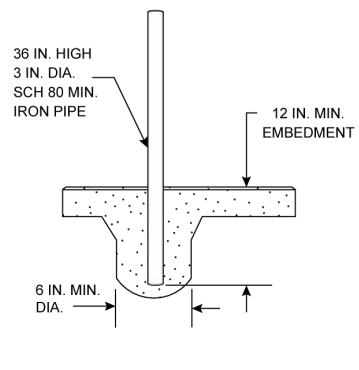
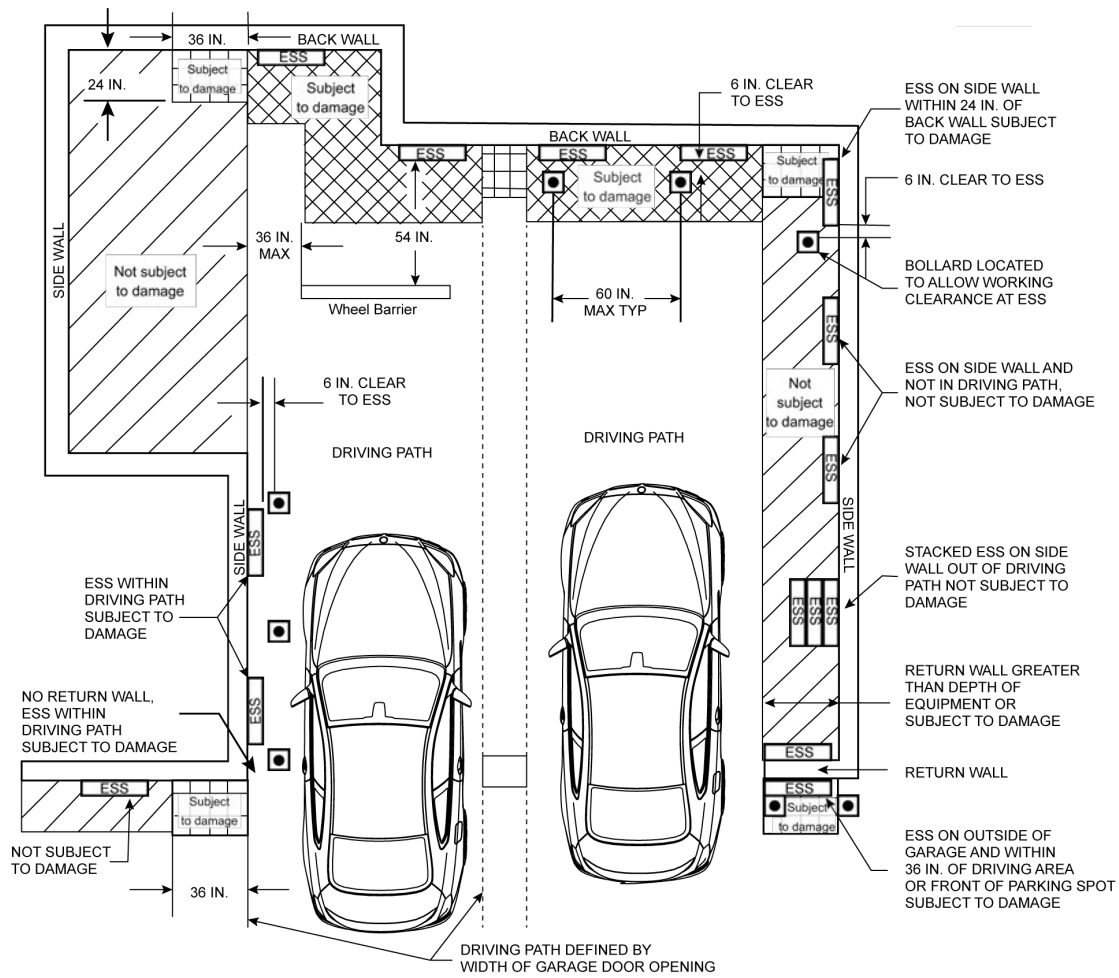
- 2.1. 4 inches (102 mm) in height by 5 inches (127 mm) in width by 70 inches (1778 mm) in length wheel barrier made of concrete or polymer, anchored to the concrete floor not less than every 36 inches (914 mm) and located not less than 54 inches (1372 mm) from the ESS. Not less than a 3 1/2 inch (89 mm) diameter concrete anchors with 3-inch (76 mm) embedment per barrier shall be used. Spacing between barriers shall be no greater than 36 inches (914 mm).

2.2. Pre-manufactured wheel barriers shall be anchored in accordance with the *manufacturer's installation instructions*.

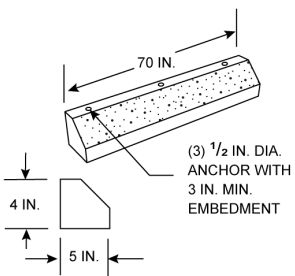
3. Approved method designed to resist a 2000 lbf (8899 Newtons) impact in the direction of travel at 24 inches (610 mm) above grade.

430.11.7 Ventilation. Indoor installations of ESS that include batteries that produce hydrogen or other flammable gases during charging shall be provided with exhaust ventilation in accordance with Section 430.8.1.

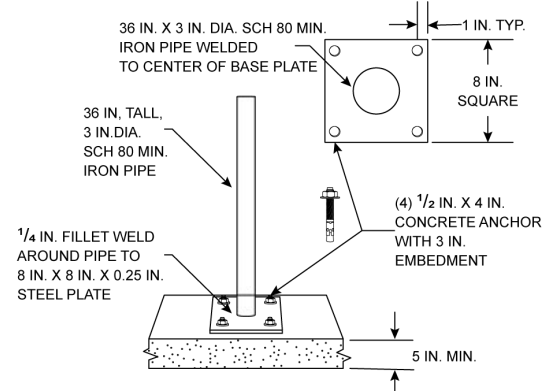
430.11.8 Toxic and highly toxic gas. ESS that have the potential to release toxic or highly toxic gas during charging, discharging and normal use conditions shall not be installed within Group R-3 or R-4 occupancies.



OPTION 1 - PIPE BOLLARD



OPTION 2 - WHEEL BARRIER



OPTION 3 - RETROFIT BOLLARD

FIGURE 430.11.6.2
ESS VEHICLE IMPACT PROTECTION

Section 431 Dry Cleaning Solvents and Systems**OSSC 431**

431.1 Scope. *Dry cleaning plants shall comply with the requirements of this section.*

431.2 Classifications. *Dry cleaning solvents and systems shall be classified in accordance with Sections 431.2.1 through 431.2.3.*

431.2.1 Solvent classification. *Dry cleaning solvents shall be classified according to their flash points as follows:*

1. *Class I solvents* are liquids having a flash point below 100°F (38°C).
2. *Class II solvents* are liquids having a flash point at or above 100°F (38°C) and below 140°F (60°C).
3. *Class IIIA solvents* are liquids having a flash point at or above 140°F (60°C) and below 200°F (93°C).
4. *Class IIIB solvents* are liquids having a flash point at or above 200°F (93°C).
5. *Class IV solvents* are liquids classified as nonflammable.

431.2.2 Classification of dry cleaning plants and systems. *Dry cleaning plants and systems shall be classified based on the solvents used as follows:*

1. Type I—systems using *Class I solvents*.
2. Type II—systems using *Class II solvents*.
3. Type III-A—systems using *Class IIIA solvents*.
4. Type III-B—systems using *Class IIIB solvents*.
5. Type IV—systems using *Class IV solvents* in which *dry cleaning* is not conducted by the public.
6. Type V—systems using *Class IV solvents* in which *dry cleaning* is conducted by the public.

431.2.2.1 Multiple solvents. *Dry cleaning plants using more than one class of solvent for dry cleaning shall be classified based on the numerically lowest solvent class.*

431.2.3 Design. *The occupancy classification, design and construction of dry cleaning plants shall comply with the applicable requirements of this code.*

431.3 Prohibited use. *Type I dry cleaning plants shall be prohibited. Limited quantities of Class I solvents stored and used in accordance with this section shall not be prohibited in dry cleaning plants.*

431.3.1 Ventilation. *Ventilation shall be provided in accordance with Section 502 of the Mechanical Code and DOL 29 CFR Part 1910.1000, where applicable.*

431.3.2 Heating. *In Type II dry cleaning plants, heating shall be by indirect means using steam, hot water or hot oil only.*

431.3.3 Bonding and grounding. *Storage tanks, treatment tanks, filters, pumps, piping, ducts, dry cleaning units, stills, tumblers, drying cabinets and other such equipment, where not inherently electrically conductive, shall be bonded together and grounded. Isolated equipment shall be grounded.*

431.4 Dry cleaning systems. *Dry cleaning systems, including dry cleaning units, washing machines, stills, drying cabinets, tumblers and their appurtenances, including pumps, piping, valves, filters and solvent coolers, shall be installed and maintained in accordance with NFPA 32. The construction of buildings in which such systems are located shall comply with the requirements of this section.*

431.4.1 Type II systems. *Type II dry cleaning and solvent tank storage rooms shall not be located below grade or above the lowest floor level of the building and shall comply with Sections 431.4.1.1 and 431.4.1.2.*

431.4.1.1 Number of means of egress. *Type II dry cleaning rooms shall have not less than two means of egress doors located at opposite ends of the room, not less than one of which shall lead directly outdoors.*

431.4.1.2 Spill control and secondary containment. *Curbs, drains or other provisions for spill control and secondary containment shall be provided in accordance with Section 415.12.1 to collect solvent leakage and fire protection water and direct it to a safe location.*

431.4.2 Solvent storage tanks. *Solvent storage tanks for Class II, IIIA and IIIB liquids shall conform to the requirements of Section 444 and be located underground or outside, above ground.*

Exception: *As provided in NFPA 32 for indoor storage or treatment tanks.*

431.5 Fire protection. *Where required by this section, fire protection systems, devices and equipment shall be installed, inspected and tested in accordance with Chapter 9.*

431.5.1 Automatic sprinkler system. *An automatic sprinkler system shall be installed in accordance with Section 903.3.1.1 throughout dry cleaning plants containing Type II, Type III-A or Type III-B dry cleaning systems.*

Exceptions:

1. *An automatic sprinkler system shall not be required in Type III-A dry cleaning plants where the aggregate quantity of Class III-A solvent in dry cleaning machines and storage does not exceed 330 gallons (1250 L) and dry*

cleaning machines are equipped with a feature that will accomplish any one of the following:

- 1.1. Prevent oxygen concentrations from reaching 8 percent or more by volume.
 - 1.2. Keep the temperature of the solvent not less than 30°F (16.7°C) below the flash point.
 - 1.3. Maintain the solvent vapor concentration at a level lower than 25 percent of the lower explosive limit (LEL).
 - 1.4. Utilize equipment approved for use in Class I, Division 2 hazardous locations in accordance with the *Electrical Code*.
 - 1.5. Utilize an integrated dry-chemical, clean agent or water-mist automatic fire-extinguishing system designed in accordance with Chapter 9.
2. An automatic sprinkler system shall not be required in Type III-B dry cleaning plants where the aggregate quantity of Class III-B solvent in dry cleaning machines and storage does not exceed 3,300 gallons (12,490 L).

431.5.2 Automatic fire-extinguishing systems. Type II dry cleaning units, washer-extractors, and drying tumblers in Type II dry cleaning plants shall be provided with an approved automatic fire-extinguishing system installed in accordance with Chapter 9.

Exception: Where approved, a manual steam jet not less than $\frac{3}{4}$ inch (19 mm) with a continuously available steam supply at a pressure not less than 15 pounds per square inch gauge (psig) (103 kPa) is allowed to be substituted for the automatic fire-extinguishing system.

Section 432 Fruit and Crop Ripening

OSSC 432

432.1 Scope. Ripening processes where ethylene gas is introduced into a room to promote the ripening of fruits, vegetables and other crops shall comply with this section.

Exception: Mixtures of ethylene and one or more inert gases in concentrations that prevent the gas from reaching greater than 25 percent of the lower explosive limit (LEL) when released to the atmosphere.

432.2 Ethylene gas location. Ethylene gas shall be discharged only into *approved* rooms or enclosures designed and constructed for this purpose.

432.3 Ethylene gas dispensing. Valves controlling discharge of ethylene shall provide positive and fail-closed control of flow and shall be set to limit the concentration of gas in air below 1,000 parts per million (ppm).

432.4 Electrical wiring and equipment. Electrical wiring and equipment, including luminaires, shall be *approved* for use in Class I, Division 2, Group C hazardous (classified) locations.

432.5 Ethylene generators. Ethylene generators shall be *listed and labeled* by an *approved* testing laboratory, *approved* by the *building official* and used only in *approved* rooms in accordance with the ethylene generator manufacturer's instructions. The listing evaluation shall include documentation that the concentration of ethylene gas does not exceed 25 percent of the lower explosive limit (LEL).

432.5.1 Ethylene generator rooms. Ethylene generators shall be used in rooms having a volume of not less than 1,000 cubic feet (28 m³). Rooms shall have air circulation to ensure even distribution of ethylene gas and shall be free from sparks, open flames or other ignition sources.

432.6 Warning signs. *Approved* warning signs indicating the danger involved and necessary precautions shall be posted on all doors and entrances to the premises.

Section 433 Lumber Yards and Woodworking Facilities**OSSC 433**

433.1 Scope. The storage, manufacturing and processing of solid biomass feedstock, timber, lumber, plywood, veneers and *agro-industrial* byproducts shall be in accordance with this section.

433.2 Dust control. Equipment or machinery located inside buildings that generates or emits *combustible dust* shall be provided with an *approved* dust collection and exhaust system installed in accordance with Section 426 and the *Mechanical Code*. Equipment or systems that are used to collect, process or convey *combustible dusts* shall be provided with an *approved* explosion control system.

433.2.1 Explosion venting. Where a dust explosion hazard exists in equipment rooms, buildings or other enclosures, such areas shall be provided with explosion (*deflagration*) venting or an *approved* explosion suppression system complying with Section 919.

433.3 Waste removal. Sawmills, planing mills and other woodworking plants shall be equipped with a waste removal system that will collect and remove sawdust and shavings. Such systems shall be installed in accordance with Section 426 and the *Mechanical Code*.

Exception: Manual waste removal where *approved*.

433.4 Electrical equipment. Electrical wiring and equipment shall comply with the *Electrical Code*.

433.4.1 Static electricity. Static electricity shall be prevented from accumulating on machines and equipment subject to static electricity buildup by permanent grounding and bonding wires or other *approved* means.

433.5 Fire protection. Fire protection in timber and lumber production mills, *plywood and veneer mills* and *agro-industrial* facilities shall comply with Sections 433.5.1 through 433.5.3.

433.5.1 Fire alarms. An *approved* means for transmitting alarms to the fire department shall be provided in timber and lumber production mills and *plywood and veneer mills*.

433.5.1.1 Manual fire alarms. A manual fire alarm system complying with Section 907.2 shall be installed in areas of timber and lumber production mills and for *plywood and veneer mills* that contain product dryers.

Exception: Where dryers or other sources of ignition are protected by a supervised *automatic sprinkler system* complying with Section 903.

433.5.2 Standpipes and hose. Standpipes and hose supplied from an *approved* water system shall be provided within a 50-foot (15 240 mm) distance of travel from any machine producing shavings or sawdust.

433.5.3 Automatic sprinkler systems. *Automatic sprinkler systems* shall be installed in accordance with Section 903.3.1.1.

433.6 Plywood, veneer and composite board mills. Plant operations of plywood, veneer and composite board mills shall comply with Sections 433.6.1 and 433.6.2.

433.6.1 Dryer protection. Dryers shall be protected throughout by an *approved*, automatic deluge water-spray suppression system complying with Chapter 9. Manual activation valves shall be located within 75 feet (22 860 mm) of the drying equipment.

433.6.2 Thermal oil-heating systems. Facilities that use heat transfer fluids to provide process equipment heat through piped, indirect heating systems shall comply with this code and NFPA 664.

433.7 Pile fire protection for the storage of wood chips and hogged material associated with timber and lumber production facilities. Automatic sprinkler protection shall be provided in conveyor tunnels and combustible enclosures that pass under a pile. Combustible or enclosed conveyor systems shall be equipped with an *approved automatic sprinkler system*.

433.8 Pile fire protection for the storage and processing of woodchips, hogged material, fines, compost, solid biomass feed stock and draw product associated with yard waste, agro-industrial and recycling facilities. Automatic sprinkler protection shall be provided in conveyor tunnels and combustible enclosures that pass under a pile. Combustible conveyor systems and enclosed conveyor systems shall be equipped with an *approved automatic sprinkler system*.

Section 434 Industrial Ovens

OSSC 434

434.1 Scope. This section shall apply to the installation and operation of industrial ovens and furnaces. Industrial ovens and furnaces shall comply with the applicable provisions of this code, NFPA 86, the *Mechanical Code* and this section. The terms “ovens” and “furnaces” are used interchangeably in this section.

434.1.1 Ventilation. Enclosed rooms or basements containing industrial ovens or furnaces shall be provided with combustion air in accordance with the *Mechanical Code*, and with ventilation air in accordance with the *Mechanical Code*.

434.1.2 Exposure. When locating ovens, oven heaters and related equipment, the possibility of fire resulting from overheating or from the escape of fuel gas or fuel oil and the possibility of damage to the building and injury to persons resulting from explosion shall be considered.

434.1.3 Ignition source. Industrial ovens and furnaces shall be located so as not to pose an ignition hazard to flammable vapors or mists or *combustible dusts*.

434.1.4 Temperatures. Roofs and floors of ovens shall be insulated and ventilated to prevent temperatures at combustible ceilings and floors from exceeding 160°F (71°C).

434.2 Fuel gas piping. Fuel gas piping serving industrial ovens shall comply with the *Mechanical Code*. Piping for other fuel sources shall comply with this section.

434.2.1 Shutoff valves. Each industrial oven or furnace shall be provided with an *approved* manual fuel shutoff valve in accordance with the *Mechanical Code*.

434.2.2 Fuel supply lines. Valves for fuel supply lines shall be located within 6 feet (1829 mm) of the appliance served.

Exception: Where *approved* and the valve is located in the same general area as the appliance served.

434.2.3 Valve position. The design of manual fuel shutoff valves shall incorporate a permanent feature that visually indicates the open or closed position of the valve. Manual fuel shutoff valves shall not be equipped with removable handles or wrenches unless the handle or wrench can only be installed parallel with the fuel line when the valve is in the open position.

434.3 Interlocks. Interlocks shall be provided for Class A ovens so that conveyors or sources of flammable or combustible materials shall shut down if either the exhaust or recirculation air supply fails.

434.4 Required fire protection. Class A and B ovens that contain or are utilized for the processing of combustible materials shall be protected by an *approved automatic fire-extinguishing system* complying with Chapter 9.

434.4.1 Fixed fire-extinguishing systems. Fixed fire-extinguishing systems shall be provided for Class C or D ovens to protect against such hazards as overheating, spillage of molten salts or metals, quench tanks, ignition of hydraulic oil and escape of fuel. It shall be the user's responsibility to consult with the *building official* concerning the necessary requirements for such protection.

434.5 Industrial oven labeling and information. An *approved*, clearly worded, and prominently displayed safety design data form or manufacturer's nameplate shall be provided stating the safe operating condition for which the furnace system was designed, built, altered or extended.

434.5.1 Oven nameplate. Safety data for Class A solvent atmosphere ovens shall be furnished on the manufacturer's nameplate. The nameplate shall provide the following design data:

1. The solvent used.
2. The number of gallons (L) used per batch or per hour of solvent entering the oven.
3. The required purge time.
4. The oven operating temperature.
5. The exhaust blower rating for the number of gallons (L) of solvent per hour or batch at the maximum operating temperature.

Exception: For low-oxygen ovens, the maximum allowable oxygen concentration shall be included in place of the exhaust blower ratings.

Section 435 High-Piled Combustible Storage**OSSC 435**

435.1 Scope. *High-piled combustible storage* shall be in accordance with this chapter. In addition to the requirements of this chapter, the following material-specific requirements shall apply:

1. Aerosols shall be in accordance with Section 439.
2. Flammable and *combustible liquids* shall be in accordance with Section 444.
3. *Hazardous materials* shall be in accordance with Sections 414 and 415.
4. Storage of combustible paper records shall be in accordance with NFPA 13.
5. Storage of *combustible fibers* shall be in accordance with Section 437.
6. General storage of combustible material shall be in accordance with Section 413.

435.2 Construction documents. At the time of building permit application for new structures designed to accommodate high-piled storage or for requesting a change of occupancy/ use, and at the time of application for a storage permit, plans and specifications shall be submitted for review and approval. In addition to the information required by Chapter 1, the storage permit submittal shall include the information specified in this section. The construction documents shall include all of the following:

1. Floor plan of the building showing locations and dimensions of *high-piled storage areas*.
2. Usable storage height for each storage area.
3. Number of tiers within each rack, if applicable.
4. *Commodity* clearance between top of storage and the sprinkler deflector for each storage arrangement.
5. Aisle dimensions between each *storage array*.
6. Maximum pile volume for each *storage array*.
7. Location and classification of commodities in accordance with Section 435.3.
8. Location of commodities that are banded or encapsulated.
9. Location of required fire department access doors.
10. Type of fire suppression and fire detection systems.
11. Location of valves controlling the water supply of ceiling and in-rack sprinklers.
12. Type, location and specifications of smoke removal and curtain board systems.
13. Dimension and location of transverse and longitudinal flue spaces.
14. Additional information regarding required design features, commodities, storage arrangement and fire protection features within the *high-piled storage area* shall be provided at the time of permit, where required by the *building official*.

435.2.1 Approved construction documents. Following approval of the *construction documents*, a copy of the *approved* plans shall be maintained on the premises in an *approved* location.

435.2.2 Approved storage layout. A floor plan, of legible size, shall be provided, mounted on a wall and protected from damage. The floor plan shall be mounted in an *approved* location and show the following:

1. Locations, dimensions and rack layout of *high-piled storage areas*.
2. Design storage height for each storage area.
3. Types of commodities.
4. *Commodity* clearance between top of storage and the sprinkler deflector for each storage arrangement.
5. Aisle dimensions between each *storage array*.
6. For palletized and solid-piled storage, the maximum pile volume for each *storage array*.
7. Location and classification of commodities in accordance with Section 435.3.
8. Location of required fire department access doors.
9. Location of valves controlling the water supply of ceiling and in-rack sprinklers.

435.3 Classification of commodities. Commodities shall be classified as Class I, II, III, IV or high hazard in accordance with Sections 435.3.1 through 435.3.9.3. Materials listed within each *commodity* classification are assumed to be unmodified for improved combustibility characteristics. Use of flame-retarding modifiers or the physical form of the material could change the classification.

435.3.1 Class I commodities. Class I commodities are noncombustible products in ordinary corrugated cartons with or without single-thickness dividers, or in ordinary paper wrappings with or without wood pallets. The amount of Group A plastics shall be limited in accordance with Section 435.3.8.

435.3.2 Class II commodities. Class II commodities are Class I products in slatted wooden crates, solid wooden boxes, multiple-thickness paperboard cartons or equivalent combustible packaging material with or without wood pallets. The amount of Group A plastics shall be limited in accordance with Section 435.3.8.

435.3.3 Class III commodities. Class III commodities are products of wood, paper, natural fiber cloth, or Group C plastics or products thereof, with or without wood pallets.

The amount of Group A plastics shall be limited in accordance with Section 435.3.8.

435.3.4 Class IV commodities. Class IV commodities are Class I, II or III products containing Group A plastics in ordinary corrugated cartons; Class I, II and III products with Group A plastic packaging; Group B plastics; and free-flowing Group A plastics with or without wood pallets. The total amount of nonfree-flowing Group A plastics shall be limited in accordance with Section 435.3.8.

435.3.5 High-hazard commodities. High-hazard commodities are products presenting special fire hazards beyond those of Class I, II, III or IV. Group A plastics not otherwise classified are included in this class.

435.3.6 Classification of plastics. Plastics shall be designated as Group A, B or C in accordance with Sections 435.3.6.1 through 435.3.6.3.

435.3.6.1 Group A plastics. Group A plastics are plastic materials having a heat of combustion that is much higher than that of ordinary combustibles, and a burning rate higher than that of Group B plastics.

435.3.6.2 Group B plastics. Group B plastics are plastic materials having a heat of combustion and a burning rate higher than that of ordinary combustibles, but not as high as those of Group A plastics.

435.3.6.3 Group C plastics. Group C plastics are plastic materials having a heat of combustion and a burning rate similar to those of ordinary combustibles.

435.3.7 Examples of commodity classification. Table 435.3.7 shall be used to determine the commodity classification for various products and materials. Products not found in the list shall be classified based on the classification descriptions in Sections 435.3.1 through 435.3.5 and the products they most nearly represent in Table 435.3.7. Table 435.3.7 considers the product and the packaging if listed with the item. Products with additional packaging consisting of Group A plastics shall be classified in accordance with Section 435.3.8.

The commodity classifications are based on products with or without wood pallets. Where plastic pallets are used, the commodity classification shall be modified in accordance with Section 435.3.9.

435.3.8 Limited quantities of Group A plastics in mixed commodities. Figures 435.3.8(1) and 435.3.8(2) shall be used to determine the commodity classification based on the quantity of Group A plastics in the following situations:

1. The product is not listed in Table 435.3.7 and contains Group A plastics.
2. The commodity contains Group A plastics and is not classified as high hazard in Table 435.3.7.
3. The product listing in Table 435.3.7 does not specifically include packaging, and the packaging material includes Group A plastics.

435.3.8.1 Classifying mixed commodities with limited Group A plastics. The percentage of Group A plastics determined in accordance with Section 435.3.8.2 shall be used in Figures 435.3.8(1) and 435.3.8(2). Results from Figure 435.3.8(1) must be compared to results from Figure 435.3.8(2) and the commodity will be classified with the highest commodity classification.

Figures 435.3.8(1) and 435.3.8(2) shall not be used to reduce the commodity classification shown in Table 435.3.7.

435.3.8.2 Percentage of Group A plastics. The pallet, if any, shall not be included when measuring the weight of the commodity (WPU or WPE) or the volume of the commodity (VPE). The pallet, if any, shall be included when measuring the weight of the entire load (WL) or the volume of the entire load (VL).

Exception: Where noncombustible pallets are used, the pallets shall not be included in the volume and weight calculations.

The percentage by weight of Group A unexpanded plastics in the load shall be calculated in accordance with Equation 4-2.

The percentage by volume of Group A expanded plastics in the load shall be calculated in accordance with Equation 4-3.

The percentage by weight of Group A expanded plastics in the load shall be calculated in accordance with Equation 4-4.

$$P_{WU} = W_{PU} / W_L \quad \text{(Equation 4-2)}$$

where:

P_{WU} = Percentage by weight of Group A unexpanded plastic.

W_{PU} = Weight of Group A unexpanded plastic in the commodity, not including the weight of the pallet, if any.

W_L = Weight of the entire load, including the weight of the pallet, if any.

$$P_{VE} = V_{PE} / V_L \quad \text{(Equation 4-3)}$$

where:

P_{VE} = Percentage by volume of Group A expanded plastic.

V_{PE} = Volume of Group A expanded plastic in the commodity, not including the volume of the pallet, if any.

V_L = Volume of the entire load, including the volume of the pallet, if any.

$$P_{WE} = W_{PE} / W_L \quad \text{(Equation 4-4)}$$

where:

P_{WE} = Percentage by weight of Group A expanded plastic.

W_{PE} = Weight of Group A expanded plastic in the commodity, not including the weight of the pallet, if any.

W_L = Weight of the entire load, including the weight of the pallet, if any.

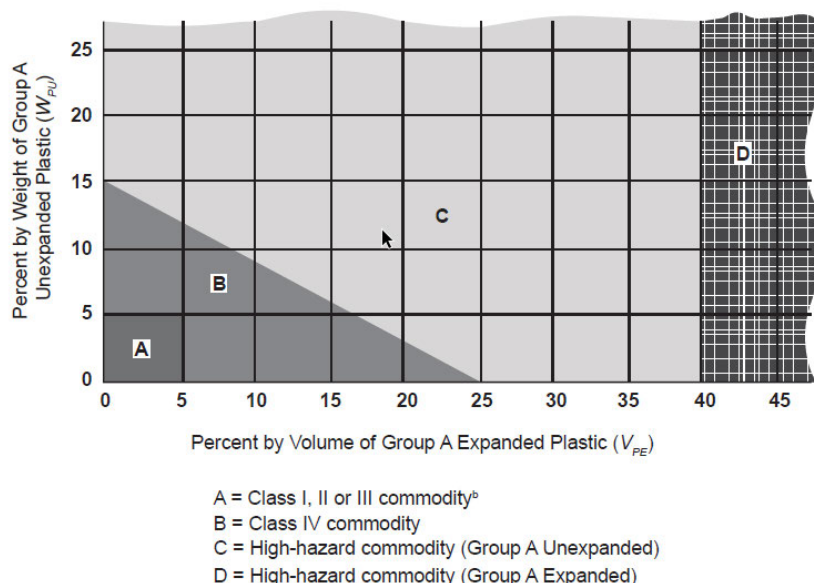


FIGURE 435.3.8(1)
EVALUATION OF CARTONED COMMODITIES CONTAINING GROUP A PLASTICS^{a,b}

- a. This figure is used to determine the commodity classification of a mixed commodity with Group A plastics in a package or crate.
- b. The following is an example of how to apply Figure 435.3.8(1): A pallet load consists of a Class III commodity in cardboard boxes with components of unexpanded Group A plastic and packing material of expanded Group A plastic. Using Equation 4-2, the weight of unexpanded Group A plastic is 5 percent. Using Equation 4-3, the volume of expanded Group A plastic is 15 percent. This commodity is classified as a Class IV commodity. If the volume of the expanded Group A plastic is increased to 20 percent, the classification changes to a high-hazard (Group A unexpanded) commodity. Where the load is stored on a plastic pallet, the requirements in Section 435.3.9 also apply.

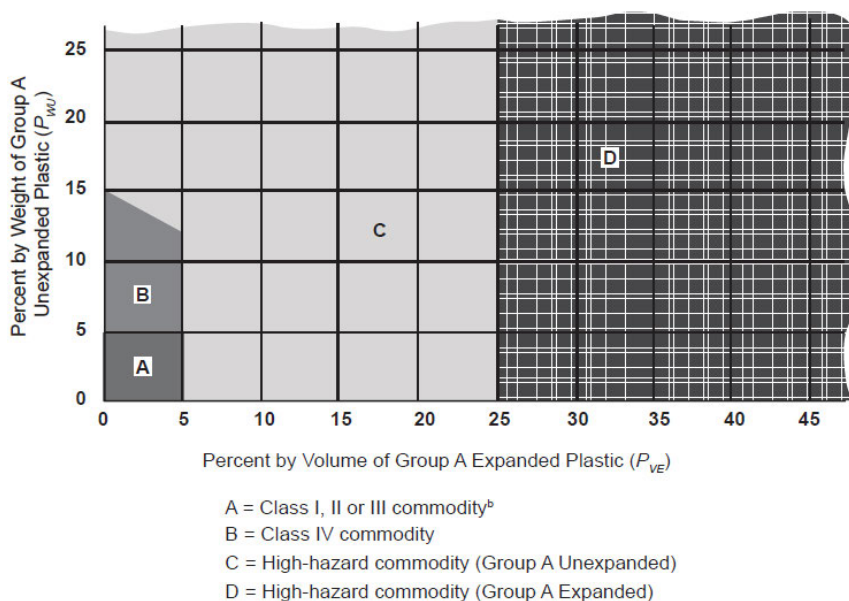


FIGURE 435.3.8(2)
EVALUATION OF EXPOSED COMMODITIES CONTAINING GROUP A PLASTICS^{a, b}

- a. This figure is used to determine the commodity classification of a mixed commodity with Group A plastics where the products are exposed.
- b. The following is an example of how to apply Figure 435.3.8(2): A pallet load consists of an exposed Class III commodity with components of unexpanded Group A plastic and packing material of expanded Group A plastic. Using Equation 4-2, the weight of unexpanded Group A plastic is 5 percent. Using Equation 4-4, the volume of expanded Group A plastic is 6 percent. This commodity is classified as a high-hazard (Group A unexpanded) commodity. Where the load is stored on a plastic pallet, the requirements in Section 435.3.9 also apply.

**TABLE 435.3.7
EXAMPLES OF COMMODITY CLASSIFICATION**

PRODUCT CATEGORY	PRODUCT	CLASSIFICATION
Aerosols	Level 1	Class III (See Section 439)
	Level 2	Class IV (See Section 439)
	Level 3	High-hazard (See Section 439)
Batteries	Dry cells (excludes lithium, lithium-ion and other similar exotic metals or combustible electrolyte); without blister packing (if blister packed, refer to the commodity classification definitions)	Class I
	Dry cells (nonlithium or similar exotic metals); in blister packing; cartoned	Class II
	Vehicle; any size (for example, automobile or truck); empty plastic casing	High-hazard (Group A unexpanded)
	Vehicle; large (in other words, truck or larger); dry or wet cells (excludes lithium-ion and other cells containing combustible electrolytes)	High-hazard (Group A unexpanded)
	Vehicle; small (for example, automobile); wet cells (excludes lithium-ion and other cells containing combustible electrolytes)	Class I
Biomass	Circular baled corn stover	Class IV
	Rectangular baled corn stover	Class III
	Rectangular baled switchgrass	High-hazard
Empty containers	Noncombustible	Class I
	PET (polyethylene terephthalate)	Class IV
	Rigid plastic (not including PET)	High-hazard (Group A unexpanded)
	Wood; solid sided (such as crates, boxes)	Class II
Film rolls, including photographic	Polypropylene, polyester, polyethylene; rolled on any reel type	High-hazard (Group A unexpanded)
	35 mm metal film cartridges in polyethylene cans; cartoned	Class III
	Motion picture or bulk rolls in polycarbonate, polyethylene or in metal cans; polyethylene bagged; cartoned	Class II
	Rolls in polycarbonate plastic cassettes; cartoned	Class IV
	Photographic paper; sheets; bagged in polyethylene; cartoned	Class III
Flammable and combustible liquids	Glycol in combustible containers (50 percent or greater)	High-hazard
	Lacquers, which dry by solvent evaporation, in metal cans or cartons	High-hazard
	Lighters; butane; blister-packed; cartoned	High-hazard (Group A unexpanded)
	Over 20-percent and up to 50-percent alcohol (such as alcoholic beverages, hair spray); up to 1-gallon glass bottles or jars; in racks; cartoned	Class III
	Over 20-percent and up to 50-percent alcohol (such as alcoholic beverages, hair spray); up to 1-gallon glass bottles or jars; palletized; cartoned	Class IV
	Over 20-percent and up to 50-percent alcohol (such as alcoholic beverages, hair spray); up to 1-gallon plastic bottles or jars; cartoned	Class IV
	Up to 20-percent alcohol (such as alcoholic beverages, flavoring extracts); greater than 5-gallon plastic containers with wall thickness greater than 0.25 inch	High-hazard (Group A unexpanded)
	Up to 20-percent alcohol (such as alcoholic beverages, flavoring extracts); metal, glass or ceramic containers	Class I

(continued)

TABLE 435.3.7—continued
EXAMPLES OF COMMODITY CLASSIFICATION

PRODUCT CATEGORY	PRODUCT	CLASSIFICATION
Flammable and combustible liquids <i>(continued)</i>	Up to 20-percent alcohol (such as alcoholic beverages, flavoring extracts); plastic containers greater than 5 gallons and wall thickness up to 1/4 inch	Class II
	Up to 20-percent alcohol (such as alcoholic beverages, flavoring extracts); up to 5-gallon plastic bottles or jars	Class I
	Up to 20-percent alcohol (such as alcoholic beverages, flavoring extracts); wood containers	Class II
	Lubricating or hydraulic fluid in plastic containers	High-hazard
	Nail polish; up to 2-ounce glass bottles or jars; cartoned	Class IV
	Nail polish; up to 2-ounce plastic bottles or jars; cartoned	High-hazard (Group A unexpanded)
Flammable solids	Except solid combustible metals	High-hazard
Food products, frozen	In nonwaxed or nonplastic packaging	Class I
	In plastic trays	Class III
	In waxed or plastic-coated paper packaging	Class II
Food products, nonfrozen	Butter (stick or whipped spread) or margarine (up to 50-percent oil)	Class III
	Butter; whipped spread	Class III
	Dry foods (such as baked goods, candy, cereals, cheese, chocolate, cocoa, coffee, grains, granular sugar, nuts); bagged or cartoned	Class III
	Foods (such as coffee, fish products, fruit, meat products, nuts, poultry); metal cans	Class I
	Fruits and vegetables (noncombustible semiliquid); crushed; plastic containers up to 5 gallons	Class I
	Fruits and vegetables; fresh; wood spacers, nonplastic trays or containers	Class I
	Margarine; over 50-percent and up to 80-percent oil	High-hazard (Group A unexpanded)
	Meat; fresh; no plastic packaging; uncartoned	Class I
	Meat; fresh; no plastic packaging; cartoned	Class II
	Meat; fresh; plastic tray	Class III
	Milk; any container; stored in solid plastic crates	High-hazard (Group A unexpanded)
	Milk; paper containers, or plastic bottles or jars up to 5 gallons	Class I
	Salt; bagged	Class I
	Salt; cartoned	Class II
Snack foods (such as potato chips); plasticized aluminum bags; cartoned	High-hazard (Group A unexpanded)	
Syrup; wooden container	Class II	
Furniture and bedding	Box spring; standard (minimal plastic materials)	Class III
	Box spring; wrapped in plastic cover	Class IV
	Furniture and bedding; with foam cushioning	High-hazard (Group A expanded)
	Furniture; metal (such as file cabinets or desks with minimal plastic trim); cartoned	Class I
	Furniture; wood (such as doors, windows, cabinets); no plastic coverings or foam cushioning	Class III
	Furniture; wood; plastic coverings; nonexpanded plastic trim	Class IV
	Mattress; foam (in finished form)	High-hazard (Group A expanded)
Pillows, foam rubber and foam plastics	High-hazard (Group A expanded)	

(continued)

TABLE 435.3.7—continued
EXAMPLES OF COMMODITY CLASSIFICATION

PRODUCT CATEGORY	PRODUCT	CLASSIFICATION
Housing materials and appliances	Appliances; major (for example, stoves, refrigerators); no appreciable plastic interior or exterior trim; cartoned	Class II
	Appliances; major (for example, stoves, refrigerators); no appreciable plastic interior or exterior trim; uncartoned	Class I
	Appliances; no appreciable plastic exterior trim (interior of unit can have appreciable plastic)	Class III
	Carpet tiles; cartoned	High-hazard (Group A unexpanded)
	Fiberglass insulation; paper-backed rolls; bagged or unbagged	Class IV
	Floor coverings; vinyl; stacked tiles	Class IV
	Floor coverings; vinyl; rolled	High-hazard (Group A unexpanded)
	Gypsum board	Class I
	Housing materials (such as sinks, countertops); noncombustible, cartoned or crated	Class II
	Light fixtures; nonplastic; cartoned	Class II
	Paint; oil-based; friction-top metal containers; cartoned	Class IV
	Paint; water-based (latex); friction-top metal containers; cartoned	Class I
	Paper; asphalt; rolled, horizontal or vertical storage	High-hazard
	Roofing shingles; asphalt-coated fiberglass	Class III
	Roofing shingles; asphalt-impregnated felt	Class IV
Miscellaneous	Ammunition; small arms and shotgun; cartoned	Class IV
	Charcoal; mineral-spirit impregnated; bagged	High-hazard (Group A expanded)
	Charcoal; standard (nonmineral-spirit impregnated); bagged	Class III
	Fertilizers; nitrates; bagged	Class II
	Fertilizers; phosphates; bagged	Class I
	Leather hides; baled	Class II
	Leather; finished products (such as shoes, jackets, gloves, bags, luggage, belts)	Class III
	Motors; electric	Class I
	Pallets and flats that are idle; combustible	High-hazard
	Shock absorbers; metal dust cover	Class II
	Shock absorbers; plastic dust cover	Class III
	Skis; wood	Class III
	Skis; composite materials (such as plastic, fiberglass, foam)	Class IV
	Tobacco products; cartoned	Class III
	Toys; stuffed; foam or synthetic	High-hazard (Group A expanded)
Transformer; dry or empty (in other words, void of oil)	Class I	

(continued)

TABLE 435.3.7—continued
EXAMPLES OF COMMODITY CLASSIFICATION

PRODUCT CATEGORY	PRODUCT	CLASSIFICATION
Noncombustible liquids	Liquids or semiliquids; PET containers greater than 5 gallons having a nominal wall thickness greater than 1/4 inch	Class IV
	Liquids or semiliquids; PET containers up to 5 gallons having a nominal wall thickness less than 1/4 inch	Class I
	Liquids or semiliquids (such as crushed fruits and vegetables); plastic containers up to 5-gallon capacity	Class I
	Liquids or semiliquids; plastic (except PET) containers greater than 5-gallon capacity having a nominal wall thickness greater than 1/4 inch	High-hazard (Group A unexpanded)
	Liquids or semiliquids; plastic (except PET) containers greater than 5-gallon capacity having a nominal wall thickness up to 1/4 inch	Class II
	Liquids; cardboard drink boxes, plastic coated, wax coated, and/or aluminum lined; uncartoned or on corrugated carton trays with plastic sheeting	Class I
	Liquids; cardboard drink boxes, plastic coated, wax coated, and/or aluminum lined; stored in plastic containers	High-hazard (Group A unexpanded)
	Liquids; glass bottles or jars; cartoned	Class I
	Liquids; less than 5-gallon plastic containers	Class I
	Liquids; pharmaceuticals (nonflammable); glass bottles or jars; cartoned	Class II
	Liquids; plastic bottles or jars; stored in open or solid plastic crates	High-hazard (Group A unexpanded)
Paper products	Book signatures (paper part of book without hard cover)	Class II
	Cartons (such as cardboard flats); corrugated; partially assembled	Class IV
	Cartons (such as cardboard flats); corrugated; unassembled in neat piles	Class III
	Cartons; wax coated, single-walled corrugated	High-hazard (Group A unexpanded)
	Cellulosic paper products; nonwax coated (such as books, cardboard games, cartoned tissue products, magazines, newspapers, paper cups, paper plates, paper towels, plastic-coated paper food containers, stationary)	Class III
	Cellulosic paper products; wax coated (such as paper plates, cups); loosely packed; cartoned	High-hazard (Group A unexpanded)
	Cellulosic paper products; wax coated (such as paper plates, cups); nested; cartoned	Class IV
	Matches; paper-type; cartoned	Class IV
	Matches; wooden; cartoned	High-hazard (Group A unexpanded)
	Rolled; lightweight; in storage racks	Class IV
	Rolled; medium or heavyweight; in storage racks or onsite	Class III
	Rolled; in horizontal storage or vertical storage that is banded or protected with an approved wrap	Class III
	Rolled; in vertical storage that is unbanded or not protected with an approved wrap	High-hazard
	Tissue products; plastic wrapped; cartoned	Class III
Tissue products; plastic wrapped; uncartoned	High-hazard (Group A unexpanded)	

(continued)

TABLE 435.3.7—continued
EXAMPLES OF COMMODITY CLASSIFICATION

PRODUCT CATEGORY	PRODUCT	CLASSIFICATION
Plastic, rubber	ABS (Acrylonitrile-butadiene-styrene copolymer)	High-hazard (Group A unexpanded)
	Acetal (polyformaldehyde)	High-hazard (Group A unexpanded)
	Acrylic (polymethyl methacrylate)	High-hazard (Group A unexpanded)
	Automobile bumpers and dashboards	High-hazard (Group A expanded)
	Butyl rubber	High-hazard (Group A unexpanded)
	Cellulose acetate	Class IV (Group B plastic)
	Cellulose acetate butyrate	High-hazard (Group A unexpanded)
	Chloroprene rubber	Class IV (Group B plastic)
	Containers; Nonexpanded plastic gridded or solid; collapsed or nested with no air spaces	High-hazard (Group A unexpanded)
	ECTFE (ethylene-chlorotrifluoro-ethylene copolymer)	Class IV (Group B plastic)
	EPDM (ethylene-propylene rubber)	High-hazard (Group A unexpanded)
	ETFE (ethylene-tetrafluoroethylene copolymer)	Class IV (Group B plastic)
	Ethyl cellulose	High-hazard (Group A unexpanded)
	FEP (fluorinated ethylene-propylene copolymer)	Class IV (Group B plastic)
	FRP (fiberglass-reinforced polyester)	High-hazard (Group A unexpanded)
	Melamine (melamine formaldehyde)	Class III (Group C plastic)
	Nitrile rubber (acrylonitrile-butadiene rubber)	High-hazard (Group A unexpanded)
	Nylon (nylon 6, nylon 6/6)	High-hazard (Group A unexpanded)
	PCTFE (polychlorotrifluoroethylene)	Class III (Group C plastic)
	PET (Polyethylene terephthalate-thermoplastic polyester)	High-hazard (Group A unexpanded)
	Phenolic	Class III (Group C plastic)
	Plastics; stored in fully closed and solid (no openings) metal containers	Class I
	Polybutadiene	High-hazard (Group A unexpanded)
Polycarbonate	High-hazard (Group A unexpanded)	
Polyester elastomer	High-hazard (Group A unexpanded)	

(continued)

TABLE 435.3.7—continued
EXAMPLES OF COMMODITY CLASSIFICATION

PRODUCT CATEGORY	PRODUCT	CLASSIFICATION
Plastic, rubber <i>(continued)</i>	Polyethylene	High-hazard (Group A unexpanded)
	Polypropylene	High-hazard (Group A unexpanded)
	Polystyrene; foam products (such as plates, cups)	High-hazard (Group A expanded)
	Polystyrene; rigid products	High-hazard (Group A unexpanded)
	Polyurethane	High-hazard (Group A expanded)
	PTFE (polytetrafluoroethylene)	Class III (Group C plastic)
	PVC (polyvinyl chloride) products; plasticizer content 20 percent or less	Class III (Group C plastic)
	PVC (polyvinyl chloride) products; plasticizer content greater than 20 percent	High-hazard (Group A unexpanded)
	PVC resins; bagged	Class III (Group C plastic)
	PVDC (polyvinylidene chloride)	Class III (Group C plastic)
	PVDF (polyvinylidene fluoride)	Class III (Group C plastic)
	PVF (polyvinyl fluoride)	High-hazard (Group A unexpanded)
	Pyroxylin	High-hazard
	Rubber; natural in blocks; cartoned	High-hazard (Group A unexpanded)
	Rubber; natural; expanded	High-hazard (Group A expanded)
	Rubber; natural; Nonexpanded	High-hazard (Group A unexpanded)
	Rubber; synthetic (santoprene)	High-hazard (Group A unexpanded)
	Rubber tires	High-hazard
	SAN (styrene acrylonitrile)	High-hazard (Group A unexpanded)
	SBR (styrene-butadiene rubber)	High-hazard (Group A unexpanded)
Silicone rubber	Class IV (Group B plastic)	
Urea (urea formaldehyde)	Class III (Group C plastic)	
Plastic containers	Bottles or jars greater than 1 gallon containing noncombustible solids	High-hazard (Group A unexpanded)
	Bottles or jars up to 1 gallon containing noncombustible solids	High-hazard (Group A unexpanded)
Powders, pills	Pharmaceutical pills; glass bottles or jars; cartoned	Class II
	Pharmaceutical pills; plastic bottles or jars; cartoned	Class IV
	Polyvinyl alcohol (PVA) resins; bagged	Class IV
	Powders; combustible (ordinary—such as sugar or flour); free-flowing; bagged	Class II
	Powders; noncombustible free-flowing powdered or granular materials (such as cement, calcium chloride, clay, iron oxide, sodium chloride, sodium silicate); bagged	Class I
	Powders; noncombustible; glass bottles or jars; cartoned	Class I
	Powders; noncombustible; PET bottles or jars	Class II
	Powders; noncombustible; plastic (other than PET) bottles or jars; uncartoned	High-hazard (Group A unexpanded)
	Powders; noncombustible; plastic bottles or jars greater than 1-gallon capacity	High-hazard (Group A unexpanded)
	Powders; noncombustible; plastic bottles or jars up to 1-gallon capacity; cartoned	Class IV

(continued)

TABLE 435.3.7—continued
EXAMPLES OF COMMODITY CLASSIFICATION

PRODUCT CATEGORY	PRODUCT	CLASSIFICATION
Textile materials and products	Cloth; natural fibers; baled	Class III
	Cloth; synthetic cloth	Class IV
	Clothing; natural fibers (such as wool, cotton) and viscose	Class III
	Cotton; cartoned	Class III
	Diapers; cotton or linen	Class III
	Diapers; plastic or nonwoven fabric; cartoned	Class IV
	Diapers; plastic or nonwoven fabric; plastic-wrapped; uncartoned	High-hazard (Group A unexpanded)
	Fabric; rayon and nylon	Class IV
	Fabric; synthetic (except rayon and nylon); greater than 50/50 blend	High-hazard (Group A unexpanded)
	Fabric; synthetic (except rayon and nylon); up to 50/50 blend	Class III
	Fabric; vinyl-coated (such as tablecloth); cartoned	High-hazard (Group A unexpanded)
	Fibers; rayon and nylon; baled	Class IV
	Fibers; synthetic (except rayon and nylon); baled	High-hazard (Group A unexpanded)
	Thread or yarn; rayon and nylon; wood or paper spools	Class IV
	Thread or yarn; rayon or nylon; plastic spools	High-hazard (Group A unexpanded)
	Thread or yarn; synthetic (except rayon and nylon); greater than 50/50 blend; paper or wood spools	Class IV
	Thread or yarn; synthetic (except rayon and nylon); greater than 50/50 blend; plastic spools	High-hazard (Group A unexpanded)
Thread or yarn; synthetic (except rayon and nylon); up to 50/50 blend; plastic spools	High-hazard (Group A unexpanded)	
Thread or yarn; synthetic (except rayon and nylon); up to 50/50 blend; wood or paper spools	Class III	
Wax products	Candles	High-hazard (Group A expanded)
	Paraffin or petroleum wax; blocks	High-hazard (Group A expanded)
Wire, cable, spools	Spools; plastic; empty	High-hazard (Group A unexpanded)
	Spools; wood; empty	Class III
	Wire or cable; PVC insulated; metal or wood spools	Class II
	Wire or cable; PVC insulated; plastic spools	Class IV
	Wire; bare; metal spools; uncartoned	Class I
	Wire; bare; metal spools; cartoned	Class II
	Wire; bare; plastic spools; cartoned	Class IV
	Wire; bare; plastic spools; uncartoned	High-hazard (Group A unexpanded)
Wire; bare; wood or cardboard spools	Class II	
Wood products	Wood patterns	Class IV
	Wood products (such as fiberboard, lumber, particle board, plywood, pressboard with smooth ends and edges); bundled solid blocks	Class II
	Wood products (such as fiberboard, lumber, particle board, plywood, pressboard with smooth ends and edges); unbundled or nonsolid blocks	Class III
	Wood products (such as toothpicks, clothespins and hangers)	Class III

For SI: 1 inch = 25.4 mm, 1 gallon = 3.8 L, 1 ounce = 29.57 ml.

435.3.9 Plastic pallets. The commodity classification determined in Section 435.3.7 or 435.3.8 shall be modified in accordance with Sections 435.3.9.1 through 435.3.9.3 where plastic pallets are used.

Exception: The commodity classification is not modified where any of the following conditions occur:

1. ... Group A plastic commodities are stored on plastic pallets.
2. ... Sprinkler protection consists of sprinklers at the ceiling only, using sprinklers with a minimum K-factor of K-16.8 (240).
3. ... The plastic pallets are listed and labeled in accordance with Section 435.6.1.1.

435.3.9.1 Unreinforced plastic pallets. For Class I through IV commodities, where unreinforced polypropylene or unreinforced high-density polyethylene plastic pallets are used, the *commodity* classification shall be increased one class. To be considered unreinforced plastic pallets, the pallets shall be marked with a permanent symbol indicating the pallet is unreinforced.

435.3.9.2 Reinforced plastic pallets. For Class I through IV commodities, where reinforced polypropylene or reinforced high-density polyethylene plastic pallets are used, the *commodity* classification shall be increased two classes except for Class IV commodities, which shall be increased to a high-hazard (Group A plastic, cartoned, unexpanded) *commodity*.

435.3.9.3 Other pallets. For Class I through IV commodities stored on plastic pallets other than polypropylene or high-density polyethylene plastic pallets, the *commodity* classification shall be increased two classes unless specific testing is conducted by a testing laboratory.

435.4 Designation of high-piled storage areas. *High-piled storage areas*, and portions of *high-piled storage areas* intended for storage of a different *commodity* class than adjacent areas, shall be designed and specifically designated to contain Class I, II, III, IV or high-hazard commodities. The designation of a *high-piled storage area*, or portion thereof intended for storage of a different *commodity* class, shall be based on the highest hazard *commodity* class stored, except as provided in Section 435.4.1.

435.4.1 Designation based on engineering analysis. The designation of a *high-piled combustible storage area*, or portion thereof, is allowed to be based on a lower hazard class than that of the highest class of *commodity* stored where a limited quantity of the higher hazard *commodity* has been demonstrated by engineering analysis to be adequately protected by the *automatic sprinkler system* provided. The engineering analysis shall consider the ability of the sprinkler system to deliver the higher density required by the higher hazard *commodity*. The higher density shall be based on the actual storage height of the pile or rack and the minimum allowable design area for sprinkler operation as set forth in the density/area figures provided in NFPA 13. The contiguous area occupied by the higher hazard *commodity* shall not exceed 120 square feet (11.1 m²) and additional areas of higher hazard *commodity* shall be separated from other such areas by 25 feet (7620 mm) or more. The sprinkler system shall be capable of delivering the higher density over a minimum area of 900 square feet (84 m²) for wet pipe systems and 1,200 square feet (111 m²) for dry pipe systems. The shape of the design area shall be in accordance with Section 903.

435.5 Fire protection and life safety features. Fire protection and life safety features for *high-piled storage areas* shall be in accordance with Sections 435.5.1 through 435.11.3.

435.5.1 Type of protection. Where required by Table 435.5.1, fire detection systems, smoke and heat removal and automatic sprinkler design densities shall be provided to protect the *high-piled storage area*.

435.5.1.1 Extent of protection. The fire safety features required in Table 435.5.1 shall extend to the lesser of 15 feet (4572 mm) beyond the *high-piled storage area* or a full-height wall. Where portions of *high-piled storage areas* have different fire protection requirements because of *commodity*, method of storage or storage height, the fire protection features required by Table 435.5.1 within this area shall be based on the most restrictive design requirements.

435.5.2 High-piled storage areas. For the application of Table 435.5.1, the size of the *high-piled storage areas* shall be determined in accordance with Sections 435.5.2.1 through 435.5.2.2.1.

435.5.2.1 Size of high-piled storage area. The size of each *high-piled storage area* shall include the footprint of the actual high-piled storage racks, shelves or piles and the following aisles:

1. Interior aisles within the footprint of the storage area.
2. An aisle around the perimeter of the footprint with a minimum width as required in Section 435.11.1 or the dimension to a wall or full-height wall, whichever is less.

435.5.2.2 Multiple high-piled storage areas. Where a building contains multiple *high-piled storage areas*, the aggregate of all *high-piled storage areas* shall be used for the application of Table 435.5.1 unless the *high-piled storage areas* are separated in accordance with one of the following:

1. *High-piled storage areas* separated by fire barriers with a minimum *fire-resistance-rating* of 1 hour constructed in accordance with Section 707.
2. In buildings equipped throughout with an *automatic sprinkler system* in accordance with Section 903.3.1.1, *high-piled storage areas* separated by 100 feet (30 480 mm) or more. The area providing the separation shall not contain *high-piled combustible storage*.

435.5.2.2.1 Multiple class high-piled storage areas. *High-piled storage areas* classified as Class I through IV not separated from *high-piled storage areas* classified as high hazard shall utilize the aggregate of all *high-piled storage areas* as high hazard for the purposes of the application of Table 435.5.1. *Multiple class high-piled storage areas*

meeting the separation requirements in Section 435.5.2.2 shall be considered as separated. The fire safety features in Table 435.5.1 shall be extended beyond the higher-hazard storage area in accordance with Section 435.5.1.1.

435.6.1.1 Plastic pallets. Plastic pallets *listed and labeled* in accordance with FM 4996 or UL 2335 shall be treated as wood pallets for determining required sprinkler protection.

Exception: Multiple class *high-piled storage areas* do not need to be separated where in accordance with Section 435.4.1.

**TABLE 435.5.1
GENERAL FIRE PROTECTION AND LIFE SAFETY REQUIREMENTS**

COMMODITY CLASS	SIZE OF HIGH-PILED STORAGE AREA ^a (square feet) (see Sections 435.5.1 and 435.5.2)	ALL STORAGE AREAS (See Sections 435.5, 435.12 and 435.13) ^b				SOLID-PILED STORAGE, SHELF STORAGE AND PALLETIZED STORAGE (see Section 435.12.2)		
		Automatic fire extinguishing system (see Section 435.6)	Fire detection system (see Section 435.7)	Fire department access doors (see Section 435.8)	Smoke and heat removal (see Section 435.9)	Maximum pile dimension ^c (feet)	Maximum permissible storage height ^d (feet)	Maximum pile volume (cubic feet)
I-IV	0-500	Not Required ^a	Not Required	Not Required	Not Required	Not Required	Not Required	Not Required
	501-2,500	Not Required ^a	Yes ^e	Not Required	Not Required	120	40	100,000
	2,501-12,000 Open to the public	Yes	Not Required	Not Required	Not Required	120	40	400,000
	2,501-12,000 Not open to the public (Option 1)	Yes	Not Required	Not Required ^g	Not Required	20	40	400,000
	2,501-12,000 Not open to the public (Option 2)	Not Required ^a	Yes	Yes	Yes ^{h,i}	120	30 ^e	200,000
	12,001-500,000	Yes	Not Required	Yes	Yes ^{h,i}	120	40	400,000
	Greater than 500,000	Yes	Not Required	Yes	Yes ^{h,i}	120	40	400,000
High hazard	0-500	Not Required ^a	Not Required	Not Required ^g	Not Required	60	Not Required	Not Required
	501-2,500 Open to the public	Yes	Not Required	Not Required ^g	Not Required	60	30	75,000
	501-2,500 Not open to the public (Option 1)	Yes	Not Required	Not Required ^g	Not Required	60	30	75,000
	501-2,500 Not open to the public (Option 2)	Not Required ^a	Yes ^e	Yes	Yes ^{h,i}	60	20	50,000
	2,501-300,000	Yes	Not Required	Yes	Yes ^{h,i}	60	30	75,000
	Greater than 300,000 ^f	Yes	Not Required	Yes	Yes ^{h,i}	60	30	75,000

For SI: 1 foot = 304.8 mm, 1 cubic foot = 0.02832 m³, 1 square foot = 0.0929 m².

- Where automatic sprinklers are required for reasons other than those in Section 435, the portion of the sprinkler system protecting the high-piled storage area shall be designed and installed in accordance with Sections 435.12 and 435.13.
- For aisles, see Section 435.11.
- Piles shall be separated by aisles complying with Section 435.11.
- For storage in excess of the height indicated, special fire protection shall be provided in accordance with Note f where required by the building official. See Sections 439 and 444 for special limitations for aerosols and flammable and combustible liquids, respectively.
- For storage exceeding 30 feet in height, Option 1 shall be used.
- Special fire protection provisions including, but not limited to, fire protection of exposed steel columns; increased sprinkler density; additional in-rack sprinklers, without associated reductions in ceiling sprinkler density; or additional fire department hose connections shall be provided where required by the building official.
- Not required where an automatic fire-extinguishing system is designed and installed to protect the high-piled storage area in accordance with Sections 435.12 and 435.13.
- Not required where storage areas are protected by either early suppression fast response (ESFR) sprinkler systems or control mode special application sprinklers with a response time index of $50(m \cdot s)^{1/2}$ or less that are listed to control a fire in the stored commodities with 12 or fewer sprinklers, installed in accordance with NFPA 13.
- Not required in frozen food warehouses used solely for storage of Class I and II commodities where protected by an approved automatic sprinkler system.

435.6 Automatic sprinklers. *Automatic sprinkler systems shall be provided in accordance with Sections 435.12, 435.13 and 435.14.*

435.6.1 Pallets. *Automatic sprinkler system requirements based on the presence of pallets shall be in accordance with NFPA 13.*

435.7 Fire detection. *Where fire detection is required by Table 435.5.1, an approved automatic fire detection system shall be installed throughout the high-piled storage area. The system shall be monitored and be in accordance with Section 907.*

435.8 Fire department access doors. *Where fire department access doors are required by Table 435.5.1, fire department access doors shall be provided in accordance Sections 435.8.1 through 435.8.7.*

435.8.1 Exterior walls without fire department access doors. *Fire department access doors are not required in an exterior wall that does not face a required fire apparatus access road provided that all of the following conditions occur:*

1. *The opposite exterior wall faces a required fire apparatus access road.*
2. *The opposite exterior wall is provided with fire department access doors.*
3. *The entire interior surface of the exterior wall is less than 150 feet (45 720 mm) away from a fire department access door.*
4. *The building is equipped throughout with an automatic sprinkler system in accordance with Section 903.3.1.1.*

435.8.2 Where located. *Where exterior walls surrounding high-piled storage areas face required fire apparatus access roads, such walls shall be provided with fire department access doors.*

435.8.3 Access to doors. *Fire department access doors shall be able to be accessed without the use of a ladder.*

435.8.4 Marking on fire department access doors. *Fire department access doors shall be labeled on the exterior side with the following sign or other approved sign:*

FIRE DEPARTMENT ACCESS DOOR DO NOT BLOCK

The lettering shall be in a contrasting color to the background. Letters shall have a minimum height of 2 inches (51 mm) with a minimum stroke of $\frac{3}{8}$ inch (10 mm).

435.8.5 Number of doors required. *The required fire department access doors shall be distributed such that the lineal distance between adjacent fire department access doors does not exceed 125 feet (38 100 mm) measured center to center.*

Exception: *The linear distance between adjacent access doors shall not exceed 200 feet (60 960 mm) in existing buildings where change in occupancy is not proposed.*

435.8.6 Door size and type. *Fire department access doors shall be not less than 3 feet (914 mm) in width and 6 feet 8 inches (2032 mm) in height. Roll-up doors shall not be considered fire department access doors unless approved.*

435.8.7 Locking devices. *Locking devices on fire department access doors shall be approved.*

435.9 Smoke and heat removal. *Where smoke and heat removal is required by Table 435.5.1, it shall be provided in accordance with Section 910.*

435.10 Fire department hose connections. *Where exit passageways are required for egress, a Class I standpipe system shall be provided in accordance with Section 905.*

435.11 Aisles. *Aisles providing access to exits and fire department access doors shall be provided in high-piled storage areas exceeding 500 square feet (46 m²), in accordance with Sections 435.11.1 through 435.11.3. Aisles separating storage piles or racks shall comply with NFPA 13. Aisles shall comply with Chapter 10.*

Exception: *Where aisles are precluded by rack storage systems, alternate methods of access and protection are allowed where approved.*

435.11.1 Width. *Aisle width shall be in accordance with Sections 435.11.1.1 and 435.11.1.2.*

Exceptions:

1. *Aisles crossing rack structures or storage piles that are used only for employee access shall be not less than 24 inches (610 mm) wide.*
2. *Aisles separating shelves classified as shelf storage shall be not less than 30 inches (762 mm) wide.*

435.11.1.1 Sprinklered buildings. *Aisles in sprinklered buildings shall be not less than 44 inches (1118 mm) wide. Aisles shall be not less than 96 inches (2438 mm) wide in high-piled storage areas exceeding 2,500 square feet (232 m²) in area that are accessible to the public and designated to contain high-hazard commodities.*

Aisles shall be not less than 96 inches (2438 mm) wide in areas open to the public where mechanical stocking methods are used.

Exceptions:

1. *Aisles in high-piled storage areas exceeding 2,500 square feet (232 m²) in area that are open to the public and designated to contain high-hazard commodities, and that are protected by a sprinkler system designed for multiple-row racks of high-hazard commodities, shall be not less than 44 inches (1118 mm) wide.*

2. Aisles in high-piled storage areas exceeding 2,500 square feet (232 m²) in area that are not open to the public and are protected by a sprinkler system designed for multiple-row racks shall be not less than 24 inches (610 mm) wide.

435.11.1.2 Nonsprinklered buildings. Aisles in nonsprinklered buildings shall be not less than 96 inches (2438 mm) wide.

435.11.2 Clear height. The required aisle width shall extend from floor to ceiling. Rack structural supports and catwalks are allowed to cross aisles at a minimum height of 6 feet 8 inches (2032 mm) above the finished floor level, provided that such supports do not interfere with fire department hose stream trajectory.

435.11.3 Dead-end aisles. Dead-end aisles shall not exceed 20 feet (6096 mm) in length in Group M occupancies. Dead-end aisles shall not exceed 50 feet (15240 mm) in length in all other occupancies.

Exception: Dead-end aisles are not limited where the length of the dead-end aisle is less than 2.5 times the least width of the dead-end aisle.

435.12 Solid-piled and shelf storage. Shelf storage and storage in solid piles, solid piles on pallets and bin box storage in bin boxes not exceeding 5 feet (1524 mm) in any dimension shall be in accordance with Section 435.5 and this section.

435.12.1 Fire protection. Where automatic sprinklers are required by Table 435.5.1, an approved automatic sprinkler system shall be installed throughout the building or to 1-hour fire barriers constructed in accordance with Section 707. Openings in such fire barriers shall be protected by opening protectives having a 1-hour fire protection rating. The design and installation of the automatic sprinkler system and other applicable fire protection shall be in accordance with this code and NFPA 13.

435.12.1.1 Shelf storage. Shelf storage greater than 12 feet (3658 mm) but less than 15 feet (4572 mm) in height shall be in accordance with the fire protection requirements set forth in NFPA 13. Shelf storage 15 feet (4572 mm) or more in height shall be protected in an approved manner with special fire protection, such as in-rack sprinklers.

435.12.2 Pile dimension and height limitations. Pile dimensions, the maximum permissible storage height and pile volume shall be in accordance with Table 435.5.1.

435.12.3 Arrays. Where an automatic sprinkler system design utilizes protection based on a closed array, array clearances shall be provided and maintained as specified by the standard used.

435.13 Rack storage. Rack storage shall be in accordance with Section 435.5 and this section. Bin boxes exceeding 5 feet (1524 mm) in any dimension shall be regulated as rack storage.

435.13.1 Fire protection. Where automatic sprinklers are required by Table 435.5.1, an approved automatic sprinkler system shall be installed throughout the building or to 1-hour fire barriers constructed in accordance with Section 707. Openings in such fire barriers shall be protected by opening protectives having a 1-hour fire protection rating. The design and installation of the automatic sprinkler system and other applicable fire protection shall be in accordance with Section 903.3.1.1.

435.13.1.1 Plastic shelves. Storage on plastic shelves shall be protected by approved specially engineered fire protection systems.

435.13.1.2 Racks with solid shelving. Racks with solid shelving having an area greater than 20 square feet (1.9 m²), measured between approved flue spaces at all four edges of the shelf, shall be in accordance with this section.

Exceptions:

1. Racks with mesh, grated, slatted or similar shelves having uniform openings not more than 6 inches (152 mm) apart, comprising not less than 50 percent of the overall shelf area, and with approved flue spaces are allowed to be treated as racks without solid shelves.
2. Racks used for the storage of combustible paper records, with solid shelving, shall be in accordance with NFPA 13.

435.13.1.2.1 Fire protection. Fire protection for racks with solid shelving shall be in accordance with NFPA 13.

435.13.2 Flue spaces. Rack storage areas protected with an automatic sprinkler system shall be provided with flue spaces in accordance with Table 435.13.2. Required flue spaces shall be maintained.

435.13.2.1 Flue space protection. Flue spaces required by Table 435.13.2 above the first tier of storage in single-, double- or multiple-row rack storage installations shall, where required by the building official, be equipped with approved protection devices. Such devices shall not be removed or modified.

435.13.3 Column protection. Steel building columns shall be protected in accordance with NFPA 13.

435.13.4 Extra-high-rack storage systems. Approval of the building official shall be obtained prior to installing extra-high-rack combustible storage.

435.13.4.1 Fire protection. Buildings with extra-high-rack combustible storage shall be protected with a specially engineered automatic sprinkler system. Extra-high-rack combustible storage shall be provided with additional special fire protection, such as separation from other buildings and additional built-in fire protection features and fire department access, where required by the building official.

435.14 Automated storage. Automated storage shall be in accordance with this section.

435.14.1 Automatic sprinklers. Where automatic sprinklers are required by Table 435.5.1, the building shall be equipped throughout with an *approved automatic sprinkler system* in accordance with Section 903.3.1.1.

435.14.2 Carousel storage. *High-piled storage areas* having greater than 500 square feet (46 m²) of carousel storage shall be provided with automatic shutdown in accordance with one of the following:

1. An automatic smoke detection system installed in accordance with Section 907, with coverage extending 15 feet (4575 mm) in all directions beyond unenclosed carousel storage systems and that sounds a local alarm at the operator's station and stops the carousel storage system upon the activation of a single detector.
2. An automatic smoke detection system installed in accordance with Section 907 and within enclosed carousel storage systems that sounds a local alarm at the operator's station and stops the carousel storage system upon the activation of a single detector.
3. A single dead-man-type control switch that allows the operation of the carousel storage system only when the operator is present. The switch shall be in the same room as the carousel storage system and located to provide for observation of the carousel system.

435.14.3 Automated rack storage. *High-piled storage areas with automated rack storage* shall be provided with a manually activated emergency shutdown switch.

435.14.3.1 Manual activated shutdown. A manually activated switch shall be provided to initiate the approved automatic shutdown process. The switch shall be clearly identified and shall be in an *approved* location.

435.14.3.2 Automatic shutdown. Automatic shutdown shall be required for *high-piled combustible storage areas greater than 500 square feet (46 m²)*. The *approved* automatic shutdown process shall commence upon any of the following events:

1. Water flow is detected in the automatic sprinkler system, if present.
2. Activation of the fire detection system, if present.

435.15 Specialty storage. Records storage facilities used for the rack or *shelf storage* of combustible paper records greater than 12 feet (3658 mm) in height shall be in accordance with Sections 435.5 and 435.13 and NFPA 13. Palletized storage of records shall be in accordance with Section 435.12.

435.15.1 Alternative fire protection. The design and installation of automatic fire-extinguishing systems in archives, vaults and record storage rooms shall be in accordance with NFPA 232.

**TABLE 435.13.2
REQUIRED FLUE SPACES FOR RACK STORAGE**

RACK CONFIGURATION	FLUE DESIGN		AUTOMATIC SPRINKLER PROTECTION		
			Sprinklers at the ceiling with or without minimum in-rack sprinklers		In-rack sprinklers at every tier
			Storage height ≤ 25 feet	Storage height > 25 feet	Any height
Single-row rack	Transverse flue space	Size ^b	3 inches	3 inches	Not required
		Vertically aligned	Not required	Yes	Not required
	Longitudinal flue space		Not required	Not required	Not required
Double-row rack (Option 1)	Transverse flue space	Size ^b	6 inches ^a	3 inches	Not required
		Vertically aligned	Not required	Yes	Not required
	Longitudinal flue space		Not required	6 inches	Not required
Double-row rack (Option 2)	Transverse flue space	Size ^b	3 inches	6 inches	Not required
		Vertically aligned	Not required	Yes	Not required
	Longitudinal flue space		6 inches	Not required	Not required
Multiple-row rack	Transverse flue space	Size ^b	6 inches	6 inches	Not required
		Vertically aligned	Not required	Yes	Not required
	Longitudinal flue space		Not required	Not required	Not required

For SI: 1 inch = 25.4 mm, 1 foot = 304.8 mm.

- a. Three-inch transverse flue spaces shall be provided not less than every 10 feet where ESFR sprinkler protection is provided.
- b. Random variations are allowed, provided that the configuration does not obstruct water penetration.

Section 436 Tire Rebuilding

OSSC 436

436.1 Construction. Tire rebuilding plants shall comply with the requirements of this code as to construction, separation from other buildings or other portions of the same building, and protection.

436.1.1 Buffing operations. Buffing operations shall comply with this section and Section 426.1.7.

436.2 Location. Buffing operations shall be located in a room separated from the remainder of the building housing the tire rebuilding or tire recapping operations by a 1-hour fire barrier.

Exception: Buffing operations are not required to be separated where all of the following conditions are met:

1. Buffing operations are equipped with an *approved* continuous automatic water-spray system directed at the point of cutting action.
2. Buffing machines are connected to particle-collecting systems providing a minimum air movement of 1,500 cubic feet per minute (cfm) (0.71 m³/s) in volume and 4,500 feet per minute (fpm) (23 m/s) in-line velocity.
3. The collecting system shall discharge the rubber particles to an *approved* outdoor noncombustible or fire-resistant *container* that is emptied at frequent intervals to prevent overflow.

436.3 Spray rooms and booths. Each spray room or *spray booth* where flammable or combustible solvents are applied shall comply with Section 416.

Section 437 Combustible Fibers

OSSC 437

437.1 Scope. The equipment, processes and operations involving *combustible fibers* shall comply with this section.

437.1.1 Applicability. Storage of *combustible fibers* in any quantity shall comply with this section.

437.2 Dust collection. Where located within a building, equipment or machinery that generates or emits *combustible fibers* shall be provided with an *approved* dust-collecting and exhaust system. Such systems shall comply with Section 426 and Section 511 of the *Mechanical Code*.

437.3 Sources of ignition. Sources of ignition shall comply with Sections 437.3.1 and 437.3.2.

437.3.1 Smoking. Smoking shall be prohibited and “No Smoking” signs provided as follows:

1. In rooms or areas where materials are stored or dispensed or used in *open systems*.
2. Facilities or areas within *facilities* that have been designated as totally “no smoking” shall have “No Smoking” signs placed at all entrances to the facility or area. Designated areas within such facilities where smoking is permitted either permanently or temporarily shall be identified with signs designating that smoking is permitted in these areas only.

Signs required by this section shall be in English as a primary language or in symbols allowed by this code.

437.3.2 Open flames. Open flames and high-temperature devices shall not be used in a manner that creates a hazardous condition. High-temperature devices and those devices utilizing an open flame shall be *listed* for use with the materials stored or used.

437.4 Loose fiber storage. Occupancies involving the indoor storage of loose *combustible fibers* in amounts exceeding the *maximum allowable quantity per control area* as set forth in Chapter 3 shall comply with Sections 437.4.1 through 437.4.5.

437.4.1 Storage of 100 cubic feet or less. Loose *combustible fibers* in quantities of not more than 100 cubic feet (3 m³) located in a structure shall be stored in a metal or metal-lined bin equipped with a self-closing cover.

437.4.2 Storage of more than 100 cubic feet to 500 cubic feet. Loose *combustible fibers* in quantities exceeding 100 cubic feet (3 m³) but not exceeding 500 cubic feet (14 m³) shall be stored in rooms enclosed with 1-hour *fire barriers* constructed in accordance with Section 707 or *horizontal assemblies* constructed in accordance with Section 711, or both, with openings protected by an *approved* opening protective assembly having a *fire protection rating* of ³/₄ hour in accordance with this code.

437.4.3 Storage of more than 500 cubic feet to 1,000 cubic feet. Loose *combustible fibers* in quantities exceeding 500 cubic feet (14 m³) but not exceeding 1,000 cubic feet (28 m³) shall be stored in rooms enclosed with 2-hour *fire barriers* constructed in accordance with Section 707 or *horizontal assemblies* constructed in accordance with Section 711, or both, with openings protected by an *approved* opening protective assembly having a *fire protection rating* of 1½ hours in accordance with this code.

437.4.4 Storage of more than 1,000 cubic feet. Loose *combustible fibers* in quantities exceeding 1,000 cubic feet (28 m³) shall be stored in rooms enclosed with 2-hour *fire barriers* constructed in accordance with Section 707 or *horizontal assemblies* constructed in accordance with Section 711, or both, with openings protected by an *approved* opening protective assembly having a *fire protection rating* of 1½ hours in accordance with this code. The storage room shall be protected by an *automatic sprinkler system* installed in accordance with Section 903.3.1.1.

437.4.5 Detached storage structure. Not more than 2,500 cubic feet (70 m³) of loose *combustible fibers* shall be stored in a detached structure suitably located, with openings protected against entrance of sparks. The structure shall not be occupied for any other purpose.

437.5 Bale size and separation in storage. Baled *combustible fibers* shall be limited to single blocks or piles not more than 25,000 cubic feet (700 m³) in volume, not including aisles or clearances. Blocks or piles of baled fiber shall be separated from adjacent storage by aisles not less than 5 feet (1524 mm) wide, or by flash-fire barriers constructed of continuous sheets of noncombustible material extending from the floor to a minimum height of 1 foot (305 mm) above the highest point of the piles and projecting not less than 1 foot (305 mm) beyond the sides of the piles.

Section 438 Processing and Extraction Facilities**OSSC 438**

438.1 Scope. Plant processing or extraction facilities shall comply with this section. The extraction process includes the act of extraction of the oils and fats by use of a solvent, *desolventizing* of the raw material, production of the *miscella*, distillation of the solvent from the *miscella* and solvent recovery. The use, storage, transfilling and handling of *hazardous materials* in these facilities shall comply with this section and other applicable provisions of this code.

438.2 Prohibited occupancies. Extraction processes utilizing flammable gases or *flammable cryogenic fluids* shall not be located in any building containing a Group A, E, I or R occupancy.

438.3 Location. The extraction equipment and extraction processes utilizing hydrocarbon solvents shall be located in a room or area dedicated to extraction.

438.4 Post-process purification and winterization. Postprocessing and winterization involving the heating or pressurizing of the *miscella* to other than normal pressure or temperature shall be *approved* and performed in an appliance listed for such use. Domestic or *commercial cooking appliances* shall not be used.

438.4.1 Industrial ovens. The use of industrial ovens shall comply with Section 434.

438.5 Use of flammable and combustible liquids. The use of flammable and *combustible liquids* for liquid extraction processes where the liquid is boiled, distilled or evaporated shall be located within a hazardous exhaust fume hood, rated for exhausting flammable vapors. Electrical equipment used within the hazardous exhaust fume hood shall be rated for use in flammable atmospheres. Heating of flammable or combustible liquids over an open flame is prohibited.

Exception: The use of a heating element not rated for flammable atmospheres, where documentation from the manufacture or *approved* testing laboratory indicates the element is rated for heating of flammable liquids.

438.6 Liquefied petroleum gas. Liquefied petroleum gases shall not be released to the atmosphere except where released in accordance with Section 7.3 of NFPA 58.

438.7 Gas detection. For extraction processes utilizing flammable gases as solvents, a gas detection system complying with Section 916 shall be provided.

438.7.1 Operation. Activation of the gas detection system shall result in all the following:

1. Initiation of distinct audible and visual alarm signals in the extraction room.
2. Deactivation of all heating systems located in the extraction room.
3. Activation of the mechanical ventilation system, where the system is interlocked with gas detection.
4. De-energize all light switches and electrical outlets.

438.7.2 Failure of the gas detection system. Failure of the gas detection system shall result in the deactivation of the heating system, activation of the mechanical ventilation system where the system is interlocked with the gas detection system, and initiation of a trouble signal to sound in an *approved* location.

438.7.3 Emergency shutoff. Extraction processes utilizing gaseous hydrocarbon-based solvents shall be provided with emergency shutoff systems in accordance with Section 445.2.3.

Section 439 Aerosols

OSSC 439

439.1 Scope. The provisions of this section and NFPA 30B shall apply to the manufacturing, storage and display of aerosol products, aerosol cooking spray products and plastic aerosol 3 products. Manufacturing of aerosol products, aerosol cooking spray products and plastic aerosol 3 products using *hazardous materials* shall also comply with Sections 414 and 415.

439.2 Containers. Metal aerosol *containers* shall be limited to a maximum size of 33.8 fluid ounces (1000 ml). Plastic aerosol *containers* shall be limited to a maximum 4 fluid ounces (118 ml) except as provided in Section 439.4.1 and 439.4.2. Glass aerosol *containers* shall be limited to a maximum 4 fluid ounces (118 ml).

439.3 Classification levels. Aerosol products shall be classified as Level 1, 2 or 3 in accordance with Table 439.3 and NFPA 30B. Aerosol products in *cartons* that are not identified in accordance with this section shall be classified as Level 3.

**TABLE 439.3
CLASSIFICATION OF AEROSOL PRODUCTS**

CHEMICAL HEAT OF COMBUSTION		AEROSOL CLASSIFICATION
Greater than (Btu/lb)	Less than or equal to (Btu/lb)	
0	8,600	1
8,600	13,000	2
13,000	—	3

For SI: 1 British thermal unit per pound = 0.002326 kJ/g.

439.4 Indoor storage of aerosol products. The indoor storage of Level 2 and 3 aerosol products shall comply with Sections 439.5 through 439.11 and NFPA 30B. Level 1 aerosol products and those aerosol products covered by Section 439.4.1 shall be considered to be equivalent to a Class III *commodity* and shall comply with the requirements for palletized or rack storage in NFPA 13.

439.4.1 Plastic aerosol products. Aerosol products in plastic *containers* larger than 4 fluid ounces (118 ml), but not to exceed 33.8 fluid ounces (1000 ml), shall be allowed only where in accordance with this section. The *commodity* classification shall be Class III *commodities*, as defined in NFPA 13 where any of the following conditions are met:

1. Base product does not have a fire point where tested in accordance with ASTM D92, and is a nonflammable *propellant*.
2. Base product does not sustain combustion as tested in accordance with Appendix H, "Method of Testing for Sustained Combustibility," in DOTn 49 CFR Part 173, and is a nonflammable *propellant*.

3. Base product contains up to 20 percent by volume (15.8 percent by weight) of ethanol, isopropyl alcohol or a combination thereof in an aqueous mix, and is a nonflammable *propellant*.
4. Base product contains 4 percent by weight or less of an emulsified flammable liquefied gas *propellant* within an aqueous base. The *propellant* shall remain emulsified for the life of the product. Where such *propellant* is not permanently emulsified, the *propellant* shall be nonflammable.

439.4.2 Plastic aerosol 3 products. Plastic aerosol 3 products shall be defined as those that meet one of the following criteria:

1. Base product does not have a fire point where tested in accordance with ASTM D92, and there is not more than 10 percent by weight flammable *propellant*.
2. Base product does not sustain combustion as tested in accordance with DOTn 49 CFR 173, Appendix H, and there is not more than 10 percent by weight flammable *propellant*.
3. Base product contains 50 percent by volume or less of flammable or combustible water-miscible alcohols in an aqueous mix, and there is not more than 10 percent by weight of flammable *propellant*.

439.4.3 Plastic aerosol X products. Plastic aerosol X products are those products, in *containers* larger than 4 fluid ounces (118 ml), that do not meet the criteria provided in Section 439.4.1 or 439.4.2.

439.4.3.1 Storage, use or handling. The storage, use or handling of plastic aerosol X products shall be prohibited.

439.5 Storage in Groups A, B, E, F, I and R. Storage of Level 2 and 3 aerosol products in occupancies in Groups A, B, E, F, I and R shall be limited to the following maximum quantities:

1. A net weight of 1,000 pounds (454 kg) of Level 2 aerosol products.
2. A net weight of 500 pounds (227 kg) of Level 3 aerosol products.
3. A combined net weight of 1,000 pounds (454 kg) of Level 2 and 3 aerosol products.

The maximum quantity shall be increased 100 percent where the excess quantity is stored in storage cabinets in accordance with Section 444.4.2.

439.5.1 Excess storage. Storage of quantities exceeding the maximum quantities indicated in Section 439.5 shall be stored in separate indoor flammable liquid storage rooms in accordance with Section 439.8.

439.5.2 Aerosol cooking spray products. Storage of aerosol cooking spray products in A, B, E, F, I and R occupancies shall be not more than 1,000 pounds (454 kg) net weight.

439.6 Storage in general purpose warehouses. Aerosol product storage in general purpose warehouses utilized only for warehousing-type operations involving mixed commodities shall comply with Section 439.6.1, 439.6.2 or 439.6.3.

439.6.1 Nonsegregated storage. Storage consisting of solid pile, palletized or rack storage of Level 2 and 3 aerosol products not segregated into areas utilized exclusively for the storage of aerosol products shall comply with Table 439.6.1.

439.6.2 Segregated storage. Storage of Level 2 and 3 aerosol products segregated into areas utilized exclusively for the storage of aerosol products shall comply with Table 439.6.2 and Sections 439.6.2.1 and 439.6.2.2.

**TABLE 439.6.1
NONSEGREGATED STORAGE OF LEVEL 2 AND 3
AEROSOL PRODUCTS IN GENERAL PURPOSE
WAREHOUSES:**

AEROSOL LEVEL	MAXIMUM NET WEIGHT PER FLOOR (pounds) ^b			
	Palletized or solid-pile storage		Rack storage	
	Unprotected	Protected ^a	Unprotected	Protected ^a
2	2,500	12,000	2,500	24,000
3	1,000	12,000	1,000	24,000
Combination 2 and 3	2,500	12,000	2,500	24,000

- For SI: 1 foot = 304.8 mm, 1 pound = 0.454 kg, 1 square foot = 0.0929 m².
- Approved automatic sprinkler system protection and storage arrangements shall comply with NFPA 30B. Sprinkler system protection shall extend 20 feet beyond the storage area containing the aerosol products.
 - Storage quantities indicated are the maximum permitted in any 50,000 square-foot area.

439.6.2.1 Chain-link fence enclosures. Chain-link fence enclosures required by Table 439.6.2 shall comply with the following:

- The fence shall be not less than No. 9 gage steel wire, woven into a maximum 2-inch (51 mm) diamond mesh.
- The fence shall be installed from the floor to the underside of the roof or ceiling above.
- Class IV and high-hazard commodities shall be stored outside the aerosol storage area and not less than 8 feet (2438 mm) from the fence.
- Access openings in the fence shall be provided with either self- or automatic-closing devices or a labyrinth opening arrangement preventing aerosol containers from rocketing through the access openings.

- Not less than two means of egress shall be provided from the fenced enclosure.

439.6.2.2 Aisles. The minimum aisle requirements for segregated storage in general purpose warehouses shall comply with Table 439.6.2.2.

439.6.3 Aerosol cooking spray products. Solid pile, palletized or rack storage of aerosol cooking spray products in a general purpose warehouse shall be not more than 2,500 pounds (1135 kg) net weight, unless protected in accordance with NFPA 30B.

**TABLE 439.6.2
SEGREGATED STORAGE OF LEVEL 2 AND 3 AEROSOL
PRODUCTS AND PLASTIC AEROSOL 3 PRODUCTS IN
GENERAL PURPOSE WAREHOUSES**

STORAGE SEPARATION	MAXIMUM SEGREGATED STORAGE AREA ^a		SPRINKLER REQUIREMENTS
	Percentage of building area (percent)	Area limitation (square feet)	
Separation area ^{e, f}	15	20,000	Notes b, c
Chain-link fence enclosure ^d	20	20,000	Notes b, c
1-hour fire-resistance-rated interior walls	20	30,000	Note b
2-hour fire-resistance-rated interior walls	25	40,000	Note b
3-hour fire-resistance-rated interior walls	30	50,000	Note b

For SI: 1 foot = 304.8 mm, 1 square foot = 0.0929 m².

- The maximum segregated storage area shall be limited to the smaller of the two areas resulting from the percentage of building area limitation and the area limitation.
- Automatic sprinkler system protection in aerosol product storage areas shall comply with NFPA 30B and be approved. Building areas not containing aerosol product storage shall be equipped throughout with an approved automatic sprinkler system in accordance with Section 903.3.1.1.
- Automatic sprinkler system protection in aerosol product storage areas shall comply with NFPA 30B and be approved. Sprinkler system protection shall extend a minimum 20 feet beyond the aerosol storage area.
- Chain-link fence enclosures shall comply with Section 439.6.2.1.
- A separation area shall be defined as an area extending outward from the periphery of the segregated aerosol product storage area as follows:
 - The limits of the aerosol product storage shall be clearly marked on the floor.
 - The separation distance shall be not less than 25 feet and maintained clear of all materials with a commodity classification greater than Class III in accordance with Section 903.3.1.1.
- Separation areas shall be permitted only where approved.

439.7 Storage in aerosol product warehouses. The total quantity of Level 2 and 3 aerosol products in a warehouse utilized for the storage, shipping and receiving of aerosol products shall not be restricted in structures complying with Sections 439.7.1 through 439.7.4.

**TABLE 439.6.2.2
SEGREGATED STORAGE AISLE WIDTHS AND DISTANCE
TO AISLES IN GENERAL PURPOSE WAREHOUSES**

STORAGE CONDITION	MINIMUM AISLE WIDTH (feet)	MAXIMUM DISTANCE FROM STORAGE TO AISLE (feet)
Solid pile or palletized ^a	4 feet between piles	25
Racks with ESFR sprinklers ^a	4 feet between racks and adjacent Level 2 and 3 aerosol product storage	25
Racks without ESFR sprinklers ^a	8 feet between racks and adjacent Level 2 and 3 aerosol product storage	25

For SI: 1 foot = 304.8 mm.

a. Sprinklers shall comply with NFPA 30B.

439.7.1 Automatic sprinkler system. Aerosol product warehouses shall be protected by an *approved wet pipe automatic sprinkler system* in accordance with NFPA 30B. Sprinkler protection shall be designed based on the highest classification level of aerosol product present.

439.7.2 Pile and palletized storage aisles. Solid pile and palletized storage shall be arranged so the maximum travel distance to an aisle is 25 feet (7620 mm). Aisles shall have a minimum width of 4 feet (1219 mm).

439.7.3 Rack storage aisles. Rack storage shall be arranged with a minimum aisle width of 8 feet (2438 mm) between rows of racks and 8 feet (2438 mm) between racks and adjacent solid pile or palletized storage. Where early suppression fast-response (ESFR) sprinklers provide automatic sprinkler protection, the minimum aisle width shall be 4 feet (1219 mm).

439.7.4 Combustible commodities. Combustible commodities other than flammable and *combustible liquids* shall be permitted to be stored in an aerosol product warehouse.

Exception: Flammable and *combustible liquids* in 1 quart (946 ml) metal containers or smaller shall be permitted to be stored in an aerosol product warehouse.

439.8 Storage in indoor flammable liquid storage rooms. Indoor flammable liquid storage rooms shall comply with Section 444. The maximum quantities of aerosol products shall comply with Section 439.8.1 or 439.8.2.

439.8.1 Storage rooms of 500 square feet or less. The storage of aerosol products in flammable liquid storage rooms less than or equal to 500 square feet (46 m²) in area shall not exceed the following quantities:

1. A net weight of 1,000 pounds (454 kg) of Level 2 aerosol products.
2. A net weight of 500 pounds (227 kg) of Level 3 aerosol products.
3. A combined net weight of 1,000 pounds (454 kg) of Level 2 and 3 aerosol products.

439.8.2 Storage rooms greater than 500 square feet. The storage of aerosol products in flammable liquid storage rooms greater than 500 square feet (46 m²) in area shall not exceed the following quantities:

1. A net weight of 2,500 pounds (1,135 kg) of Level 2 aerosol products.
2. A net weight of 1,000 pounds (454 kg) of Level 3 aerosol products.
3. A combined net weight of 2,500 pounds (1,135 kg) of Level 2 and 3 aerosol products.

The maximum aggregate storage quantity of Level 2 and 3 aerosol products permitted in separate indoor storage rooms protected by an *approved automatic sprinkler system* in accordance with NFPA 30B shall be 5,000 pounds (2,270 kg).

439.9 Storage in liquid warehouses. The storage of Level 2 and 3 aerosol products in liquid warehouses shall comply with NFPA 30B. The storage shall be located within *segregated storage areas* in accordance with Section 439.6.2 and Sections 439.9.1 through 439.9.3.

439.9.1 Containment. Spill control or drainage shall be provided to prevent the flow of liquid to within 8 feet (2438 mm) of the *segregated storage area*.

439.9.2 Sprinkler design. Sprinkler protection shall be designed based on the highest level of aerosol product present.

439.9.3 Opening protection into segregated storage areas. Fire doors or gates opening into the *segregated storage area* shall either be self-closing or provided with automatic-closing devices activated by sprinkler water flow or an *approved fire detection system*.

439.10 Storage in Group M occupancies. Storage of Level 2 and 3 aerosol products, aerosol cooking spray products, and plastic aerosol 3 products in occupancies in Group M shall comply with Table 439.10. Retail display shall comply with Section 439.12.

**TABLE 439.10
MAXIMUM QUANTITIES OF LEVEL 2 AND 3 AEROSOL
PRODUCTS AND AEROSOL COOKING SPRAY PRODUCTS
AND PLASTIC AEROSOL 3 PRODUCTS IN RETAIL
STORAGE AREAS**

Floor	MAXIMUM NET WEIGHT PER FLOOR (pounds)		
	Nonsegregated storage ^{a,b}	Segregated storage	
		Storage cabinets ^b	Separated from retail area ^c
Basement	Not Permitted	Not Permitted	Not Permitted
Ground	2,500	5,000	Note d
Upper	500	1,000	Note d

For SI: 1 pound = 0.454 kg, 1 square foot = 0.0929 m².

- a. The total aggregate quantity on display and in storage shall not exceed the maximum retail display quantity indicated in Section 439.12.2.
- b. Storage quantities indicated are the maximum permitted in any 50,000-square-foot area.
- c. The storage area shall be separated from the retail area with a 1-hour fire-resistance-rated assembly.
- d. See Table 439.6.2.

439.11 Storage of aerosol cooking spray products. *Aerosol cooking spray products* shall be permitted to be stored in a general purpose warehouse.

439.11.1 Mixed storage. Where *aerosol cooking spray products* are mixed with other higher-hazard aerosol products, the provided isolation, storage height restrictions and protection shall be based on the highest-hazard aerosol product present.

439.11.2 Storage conditions. The storage and handling of *aerosol cooking spray products* shall comply with this section and NFPA 30B.

439.12 Retail display. This section shall apply to the retail display of 500 pounds (227 kg) or more of Level 2 and 3 aerosol products, aerosol cooking spray products and plastic aerosol 3 products.

439.12.1 Aerosol display and normal merchandising not exceeding 8 feet high. Aerosol display and normal merchandising not exceeding 8 feet (2438 mm) in height shall be in accordance with Sections 439.12.1.1 through 439.12.1.5.

439.12.1.1 Maximum quantities in retail display areas. Aerosol products, aerosol cooking spray products and plastic aerosol 3 products in *retail display areas* shall not exceed quantities needed for display and normal merchandising and shall not exceed the quantities in Table 439.12.1.1.

TABLE 439.12.1.1
MAXIMUM QUANTITIES OF LEVEL 2 AND 3 AEROSOL PRODUCTS, AEROSOL COOKING SPRAY PRODUCTS, AND PLASTIC AEROSOL 3 PRODUCTS IN RETAIL DISPLAY AREAS

MAXIMUM NET WEIGHT PER FLOOR (pounds) ^b			
Floor	Unprotected ^a	Protected in accordance with Section 439.12.1 ^{a,c}	Protected in accordance with Section 439.12.2 ^c
Basement	Not Allowed	500	500
Ground	2,500	10,000	10,000
Upper	500	2,000	Not Allowed

For SI: 1 pound = 0.454 kg, 1 square foot = 0.0929 m².

- The total quantity shall not exceed 1,000 pounds net weight in any one 100-square-foot retail display area.
- Per 25,000-square-foot retail display area.
- Minimum Ordinary Hazard Group 2 wet pipe automatic sprinkler system throughout the retail sales occupancy.

439.12.1.2 Aerosol cooking spray product and plastic aerosol 3 product storage and fire protection. The storage and handling of *aerosol cooking spray products* and plastic aerosol 3 products shall comply with this section and NFPA 30B.

439.12.1.3 Display of aerosol products. Level 2 and 3 aerosol products shall not be stacked more than 6 feet (1829 mm) high from the base of the aerosol product array to the top of the aerosol product array unless the aerosol products are placed on fixed shelving or otherwise secured in an *approved* manner. Where storage or retail display is on shelves, the height of such storage or retail display to the top of aerosol products shall not exceed 8 feet (2438 mm).

439.12.1.4 Combustible cartons. *Aerosol products* located in *retail display areas* shall be removed from combustible *cartons*.

Exceptions:

- Display areas that use a portion of combustible *cartons* that consist of only the bottom panel and not more than 2 inches (51 mm) of the side panel are allowed.
- Where the display area is protected in accordance with Tables 6.3.2.7(a) through 6.3.2.7(l) of NFPA 30B, storage of aerosol products in combustible *cartons* is allowed.

439.12.1.5 Retail display automatic sprinkler system. Where an *automatic sprinkler system* is required for the protected retail display of aerosol products, the wet pipe *automatic sprinkler system* shall be in accordance with Section 903.3.1.1. The minimum system design shall be for an Ordinary Hazard Group 2 occupancy. The system shall be provided throughout the *retail display area*.

439.12.2 Aerosol product display and normal merchandising exceeding 8 feet high. Aerosol product display and merchandising exceeding 8 feet (2438 mm) in height shall be in accordance with Sections 439.12.2.1 through 439.12.2.3.

439.12.2.1 Maximum quantities in retail display areas. Aerosol products and plastic aerosol 3 products in *retail display areas* shall not exceed quantities needed for display and normal merchandising and shall not exceed the quantities in Table 439.12.1.1, with fire protection in accordance with Section 439.12.2.2.

439.12.2.2 Automatic sprinkler protection. Aerosol product and plastic aerosol 3 product display and merchandising areas shall be protected by an *automatic sprinkler system* based on the requirements set forth in Tables 6.4.2.7(a) through 6.4.2.7(l) of NFPA 30B and the following:

- Protection shall be based on the highest level of aerosol product in the array and the packaging method of the storage located more than 6 feet (1829 mm) above the finished floor.
- Where using the cartoned aerosol products tables of NFPA 30B, uncartoned or display-cut Level 2 and 3 aerosol products and plastic aerosol 3 products shall not be permitted more than 6 feet (1829 mm) above the finished floor.
- The design area for Level 2 and 3 aerosol products and plastic aerosol 3 products shall extend not less than 20 feet (6096 mm) beyond the Level 2 and 3 aerosol product and plastic aerosol 3 product display and merchandising areas.
- Where ordinary and high-temperature ceiling sprinkler systems are adjacent to each other, noncombustible *draft curtains* shall be installed at the interface.

439.12.2.3 Separation of Level 2 and 3 aerosol product and plastic aerosol 3 product areas. Separation of Level 2 and 3 aerosol product areas and plastic aerosol 3 product areas shall comply with the following:

1. Level 2 and 3 aerosol product or plastic aerosol 3 product display and merchandising areas shall be separated from each other by not less than 25 feet (7620 mm). See Table 439.12.1.1.
2. Level 2 and 3 aerosol product or plastic aerosol 3 product display and merchandising areas shall be separated from flammable and combustible liquids storage and display areas by one or a combination of the following:
 - 2.1. Segregating areas from each other by horizontal distance of not less than 25 feet (7620 mm).
 - 2.2. Isolating areas from each other by a noncombustible partition extending not less than 18 inches (457 mm) above the merchandise.
 - 2.3. In accordance with Section 439.12.4.
3. Where Item 2.2 is used to separate Level 2 or 3 aerosol products from flammable or combustible liquids, and the aerosol products are located within 25 feet (7620 mm) of flammable or combustible liquids, the area below the noncombustible partition shall be liquid tight at the floor to prevent spilled liquids from flowing beneath the aerosol products.

439.12.3 Maximum quantities in storage areas. Aerosol products in storage areas adjacent to retail display areas shall not exceed the quantities in Table 439.12.3.

439.12.4 Special protection design for Level 2 and 3 aerosol products adjacent to flammable and combustible liquids in double-row racks. The display and merchandising of Level 2 and 3 aerosol products adjacent to flammable and combustible liquids in double-row racks shall be in accordance with Section 439.12.2.3

or Sections 439.12.4.1 through 439.12.4.8.

439.12.4.1 Fire protection. Fire protection for the display and merchandising of Level 2 and 3 aerosols in double-row racks shall be in accordance with Table 7.5.1 and Figure 7.5.1 of NFPA 30B.

439.12.4.2 Cartoned aerosol products. Level 2 and 3 aerosol products displayed or merchandised more than 8 feet (2438 mm) above the finished floor shall be in cartons.

439.12.4.3 Shelving. Shelving in racks shall be limited to wire mesh shelving having uniform openings not more than 6 inches (152 mm) apart, with the openings comprising not less than 50 percent of the overall shelf area.

439.12.4.4 Aisles. Racks shall be arranged so that aisles not less than 7½ feet (2286 mm) wide are maintained between rows of racks and adjacent solid-piled or palletized merchandise.

439.12.4.5 Flue spaces. Flue spaces in racks shall comply with the following:

1. Transverse flue spaces—Nominal 3-inch (76 mm) transverse flue spaces shall be maintained between merchandise and rack uprights.
2. Longitudinal flue spaces—Nominal 6-inch (152 mm) longitudinal flue spaces shall be maintained.

439.12.4.6 Horizontal barriers. Horizontal barriers constructed of minimum 3/8-inch-thick (10 mm) plywood or minimum 0.034-inch (0.086 mm) (No. 22 gage) sheet metal shall be provided and located in accordance with Table 7.5.1 and Figure 7.5.1 of NFPA 30B where in-rack sprinklers are installed.

439.12.4.7 Class I, II, III, IV and plastic commodities. Class I, II, III, IV and plastic commodities located adjacent to Level 2 and 3 aerosol products and plastic aerosol 3 products shall be protected in accordance with NFPA 13.

**TABLE 439.12.3
MAXIMUM STORAGE QUANTITIES FOR STORAGE AREAS ADJACENT TO RETAIL DISPLAY OF LEVEL 2 AND 3 AEROSOL PRODUCTS AND PLASTIC AEROSOL 3 PRODUCTS**

Floor	MAXIMUM NET WEIGHT PER FLOOR (pounds)		
	Unseparated ^{a, b}	Separated	
		Storage Cabinets ^P	1-hour Occupancy Separation
Basement	Not Allowed	Not Allowed	Not Allowed
Ground	2,500	5,000	In accordance with Sections 6.4.4.3 and 6.4.4.4 of NFPA 30B
Upper	500	1,000	In accordance with Sections 6.4.4.3 and 6.4.4.4 of NFPA 30B

For SI: 1 pound = 0.454 kg, 1 square foot = 0.0929 m².

a. The aggregate quantity in storage and retail display shall not exceed the quantity limits for retail display.

b. In any 50,000-square-foot area.

439.12.4.8. Flammable and combustible liquids.

Class I, II, IIIA and IIIB liquids shall be allowed to be located adjacent to Level 2 and 3 aerosol products where both of the following conditions are met:

1. Class I, II, IIIA and IIIB liquid containers: Containers for Class I, II, IIIA and IIIB liquids shall be limited to 1.06-gallon (4 L) metal-relieving and nonrelieving style containers and 5.3-gallon (20 L) metal-relieving style containers.
2. Fire protection for Class I, II, IIIA and IIIB liquids: Automatic sprinkler protection for Class I, II, IIIA and IIIB liquids shall be in accordance with Section 444.

439.13. Manufacturing facilities. Manufacturing facilities shall be in accordance with NFPA 30B.

Section 440 Compressed Gases**OSSC 440**

440.1 Scope. Storage, use and handling of *compressed gases in compressed gas containers, cylinders, tanks and systems shall comply with this section and NFPA 55, including those gases regulated elsewhere in this code. Partially full compressed gas containers, cylinders or tanks containing residual gases shall be considered as full for the purposes of the controls required.*

Liquefied natural gas for use as a vehicular fuel shall also comply with NFPA 52 and NFPA 59A.

Compressed gases classified as hazardous materials shall also comply with Sections 414 and 415 for general requirements and sections addressing specific hazards, including Sections 445 (Flammable Gases), 447 (Highly Toxic and Toxic Materials), 450 (Oxidizers, Oxidizing Gases and Oxidizing Cryogenic Fluids) and 451 (Pyrophoric Materials).

Compressed hydrogen (CH₂) shall also comply with the applicable portions of Sections 406 and 445, the *Mechanical Code* and NFPA 2.

Exceptions:

1. Gases used as *refrigerants in refrigeration systems* (see Chapter 28).
2. Compressed natural gas (CNG) for use as a vehicular fuel shall comply with Section 406, NFPA 52 and the *Mechanical Code*.
3. *Cryogenic fluids* shall comply with Section 442.
4. LP-gas shall comply with Section 448 and the *Mechanical Code*.

440.2 Marking. Stationary and portable *compressed gas containers, cylinders, tanks and systems shall be marked in accordance with Section 440.2.1.*

440.2.1 Stationary compressed gas containers, cylinders and tanks. Stationary *compressed gas containers, cylinders and tanks shall be marked with the name of the gas and in accordance with Sections 414.8 and 414.9. Markings shall be visible from any direction of approach.*

440.3 Security. *Compressed gas containers, cylinders, tanks and systems shall be secured against accidental dislodgement and against access by unauthorized personnel in accordance with Sections 440.3.1 through 440.3.3.*

440.3.1 Security of areas. Areas used for the storage, use and handling of *compressed gas containers, cylinders, tanks and systems shall be secured against unauthorized entry and safeguarded in an approved manner.*

440.3.2 Physical protection. *Compressed gas containers, cylinders, tanks and systems that could be exposed to physical damage shall be protected. Guard*

posts or other approved means shall be provided to protect compressed gas containers, cylinders, tanks and systems indoors and outdoors from vehicular damage and shall comply with Section 912.4.4.

440.3.3 Securing compressed gas containers, cylinders and tanks. *Compressed gas containers, cylinders and tanks shall be secured to prevent falling caused by contact, vibration or seismic activity. Securing of compressed gas containers, cylinders and tanks shall be by one of the following methods:*

1. Securing *containers, cylinders and tanks to a fixed object with one or more restraints.*
2. Securing *containers, cylinders and tanks on a cart or other mobile device designed for the movement of compressed gas containers, cylinders or tanks.*
3. *Nesting of compressed gas containers, cylinders and tanks at container filling or servicing facilities or in sellers' warehouses not open to the public. Nesting shall be allowed provided that the nested containers, cylinders or tanks, if dislodged, do not obstruct the required means of egress.*
4. Securing of *compressed gas containers, cylinders and tanks to or within a rack, framework, cabinet or similar assembly designed for such use.*

Exception: *Compressed gas containers, cylinders and tanks in the process of examination, filling, transport or servicing.*

440.4 Valve protection. *Compressed gas container, cylinder and tank valves shall be protected from physical damage by means of protective caps, collars or similar devices in accordance with Sections 440.4.1 and 440.4.2.*

440.4.1 Compressed gas container, cylinder or tank protective caps or collars. *Compressed gas containers, cylinders and tanks designed for protective caps, collars or other protective devices shall have the caps or devices in place except when the containers, cylinders or tanks are in use or are being serviced or filled.*

440.4.2 Caps and plugs. *Compressed gas containers, cylinders and tanks designed for valve protection caps or other protective devices shall have the caps or devices in place. When outlet caps or plugs are installed, they shall be in place.*

Exception: *Compressed gas containers, cylinders or tanks in use, being serviced or being filled.*

440.5 Separation from hazardous conditions. *Compressed gas containers, cylinders and tanks and systems in storage or use shall be separated from materials and conditions that pose exposure hazards to or*

from each other. *Compressed gas containers, cylinders, tanks and systems in storage or use shall be separated in accordance with Sections 440.5.1 through 440.5.4.2.*

440.5.1 Incompatible materials. *Compressed gas containers, cylinders and tanks shall be separated from each other based on the hazard class of their contents. Compressed gas containers, cylinders and tanks shall be separated from incompatible materials in accordance with Section 414.19.*

440.5.2 Exhausted enclosures. *Where exhausted enclosures are provided as a means to segregate compressed gas containers, cylinders and tanks from exposure hazards, such enclosures shall comply with the requirements of Section 414.12.*

440.5.3 Gas cabinets. *Where gas cabinets are provided as a means to separate compressed gas containers, cylinders and tanks from exposure hazards, such gas cabinets shall comply with the requirements of Section 414.13.*

440.5.4 Tube trailers. *Tube trailers, including those containing compatible compressed gases, shall be surrounded by a clear space of not less than 3 feet (914 mm) to allow for maintenance, access and inspection.*

440.5.4.1 Individual tube trailers containing incompatible materials. *Increased separation distances between individual tube trailers containing incompatible gases shall be provided where required by Section 440.7.1.*

440.5.4.2 Connections. *Piping systems used to connect tube trailers to a user piping system shall not be viewed as an encroachment into the 3-foot (914 mm) clear space.*

440.6 Vaults. *Generation, compression, storage and dispensing equipment for compressed gases shall be allowed to be located in either above- or below-grade vaults complying with Sections 440.6.1 through 440.6.14.*

440.6.1 Listing required. *Vaults shall be listed by a nationally recognized testing laboratory.*

Exception: *Where approved by the building official, below-grade vaults are allowed to be constructed onsite, provided that the design is in accordance with this code and that special inspections are conducted to verify structural strength and compliance of the installation with the approved design in accordance with Section 1707. Installation plans for below-grade vaults that are constructed on-site shall be prepared by, and the design shall bear the stamp of, a professional engineer. Consideration shall be given to soil and hydrostatic loading on the floors, walls and lid; anticipated seismic forces; uplifting by ground water or flooding; and loads imposed from above, such as traffic and equipment loading on the vault lid.*

440.6.2 Design and construction. *The vault shall completely enclose generation, compression, storage or dispensing equipment located in the vault. There shall not be openings in the vault enclosure except those necessary for vault ventilation and access, inspection, filling, emptying or venting of equipment in the vault. The walls and floor of the vault shall be constructed of reinforced concrete not less than 6 inches (152 mm) thick. The top of an above-grade vault shall be constructed of noncombustible material and shall be designed to be weaker than the walls of the vault to ensure that the thrust of any explosion occurring inside the vault is directed upward.*

The top of an at- or below-grade vault shall be designed to relieve safely or contain the force of an explosion occurring inside the vault. The top and floor of the vault and the tank foundation shall be designed to withstand the anticipated loading, including loading from vehicular traffic, where applicable. The walls and floor of a vault installed below grade shall be designed to withstand anticipated soil and hydrostatic loading. Vaults shall be designed to be wind and earthquake resistant, in accordance with this code.

440.6.3 Secondary containment. *Vaults shall be substantially liquid tight and there shall not be backfill within the vault. The vault floor shall drain to a sump. For premanufactured vaults, liquid tightness shall be certified as part of the listing provided by a nationally recognized testing laboratory. For field-erected vaults, liquid tightness shall be certified in an approved manner.*

440.6.4 Internal clearance. *There shall be sufficient clearance within the vault to allow for visual inspection and maintenance of equipment in the vault.*

440.6.5 Anchoring. *Vaults and equipment contained therein shall be suitably anchored to withstand uplifting by groundwater or flooding. The design shall verify that uplifting is prevented even where equipment within the vault is empty.*

440.6.6 Vehicle impact protection. *Vaults shall be resistant to damage from the impact of a motor vehicle, or vehicle impact protection shall be provided in accordance with Section 912.4.4.*

440.6.7 Arrangement. *Equipment in vaults shall be listed or approved for above-ground use. Where multiple vaults are provided, adjacent vaults shall be allowed to share a common wall. The common wall shall be liquid and vapor tight and shall be designed to withstand the load imposed when the vault on either side of the wall is filled with water.*

440.6.8 Connections. *Connections shall be provided to permit the venting of each vault to dilute, disperse and remove vapors prior to personnel entering the vault.*

440.6.9 Ventilation. Vaults shall be provided with an exhaust ventilation system installed in accordance with Section 415.12.3. The ventilation system shall operate continuously or be designed to operate upon activation of the vapor or liquid detection system. The system shall provide ventilation at a rate of not less than 1 cubic foot per minute (cfm) per square foot [$0.00508 \text{ m}^3/(\text{s} \times \text{m}^2)$] of floor area, but not less than 150 cfm ($4 \text{ m}^3/\text{min}$). The exhaust system shall be designed to provide air movement across all parts of the vault floor for gases having a density greater than air and across all parts of the vault ceiling for gases having a density less than air. Supply ducts shall extend to within 3 inches (76 mm), but not more than 12 inches (305 mm), of the floor. Exhaust ducts shall extend to within 3 inches (76 mm), but not more than 12 inches (305 mm) of the floor or ceiling, for heavier-than-air or lighter-than-air gases, respectively. The exhaust system shall be installed in accordance with the *Mechanical Code*.

440.6.10 Monitoring and detection. Vaults shall be provided with approved vapor and liquid detection systems and equipped with on-site audible and visual warning devices with battery backup. Vapor detection systems shall sound an alarm when the system detects vapors that reach or exceed 25 percent of the lower explosive limit (LEL) or one-half the IDLH concentration for the gas in the vault. Vapor detectors shall be located not higher than 12 inches (305 mm) above the lowest point in the vault for heavier-than-air gases and not lower than 12 inches (305 mm) below the highest point in the vault for lighter-than-air gases. Liquid detection systems shall sound an alarm upon detection of any liquid, including water. Liquid detectors shall be located in accordance with the manufacturer's instructions. Activation of either vapor or liquid detection systems shall cause a signal to be sounded at an approved, constantly attended location within the facility served by the tanks or at an approved location. Activation of vapor detection systems shall shut off gas-handling equipment in the vault and dispensers.

440.6.11 Liquid removal. Means shall be provided to recover liquid from the vault. Where a pump is used to meet this requirement, it shall not be permanently installed in the vault. Electric-powered portable pumps shall be suitable for use in Class I, Division 1 locations, as defined in the *Electrical Code*.

440.6.12 Relief vents. Vent pipes for equipment in the vault shall terminate not less than 12 feet (3658 mm) above ground level.

440.6.13 Accessway. Vaults shall be provided with an approved personnel accessway with a minimum dimension of 30 inches (762 mm) and with a permanently affixed, nonferrous ladder. Accessways shall be designed to be nonsparking. Travel distance from any point inside a vault to an accessway shall not exceed 20 feet (6096 mm). At each entry point, a

warning sign indicating the need for procedures for safe entry into confined spaces shall be posted. Entry points shall be secured against unauthorized entry and vandalism.

440.6.14 Classified area. The interior of a vault containing a flammable gas shall be designated a Class I, Division 1 location, as defined in the *Electrical Code*.

440.7 Storage of compressed gas. Compressed gas containers, cylinders and tanks, except those designed for use in a horizontal position, and all compressed gas containers, cylinders and tanks containing nonliquefied gases shall be stored in an upright position with the valve end up. An upright position shall include conditions where the container, cylinder or tank axis is inclined as much as 45 degrees (0.80 rad) from vertical.

Exceptions:

1. Compressed gas containers with a water volume less than 1.3 gallons (5 L) are allowed to be stored in a horizontal position.
2. Cylinders, containers and tanks containing nonflammable gases, or cylinders, containers and tanks containing nonliquefied flammable gases that have been secured to a pallet for transportation purposes.

440.7.1 Material-specific regulations. In addition to the requirements of this section, indoor and outdoor storage of compressed gases shall comply with the material-specific provisions of Sections 441, 445 and 447 through 454.

440.8 Use and handling of compressed gases. The use and handling of compressed gas systems shall be in accordance with Sections 440.8.1 through 440.8.4.

440.8.1 Compressed gas systems. Compressed gas systems shall be suitable for the use intended and shall be designed by persons competent in such design. Compressed gas equipment, machinery and processes shall be listed or approved.

440.8.2 Controls. Compressed gas system controls shall be designed to prevent materials from entering or leaving process or reaction systems at other than the intended time, rate or path. Automatic controls shall be designed to be fail safe.

440.8.3 Valves. Valves utilized on compressed gas systems shall be suitable for the use intended. Access to such valves shall be provided and maintained. Valve handles or operators for required shutoff valves shall not be removed or otherwise altered to prevent access.

440.8.4 Venting. Venting of gases shall be directed to an approved location. Venting shall comply with the *Mechanical Code*.

440.9 Medical gases. Medical gases at health care-related facilities intended for patient or veterinary care shall comply with Sections 440.9.1 and 440.9.2 in addition to other requirements of this section and Section 427.

440.9.1 Interior supply location. Medical gases shall be located in areas dedicated to the storage of such gases without other storage or uses. Where containers of medical gases in quantities greater than the permitted amounts set forth in Table 427.2 are located inside buildings, they shall be in a 1-hour exterior room, a 1-hour interior room or a gas cabinet in accordance with Section 440.9.1.1, 440.9.1.2 or 440.9.1.3, respectively. Rooms or areas where medical gases are stored or used in quantities exceeding the maximum allowable quantity per control area as set forth in this code shall be in accordance with this code for high-hazard Group H occupancies.

440.9.1.1 One-hour exterior rooms. A 1-hour exterior room shall be a room or enclosure separated from the remainder of the building by fire barriers constructed in accordance with Section 707 or horizontal assemblies constructed in accordance with Section 711, or both, with a fire-resistance rating of not less than 1 hour. Openings between the room or enclosure and interior spaces shall be self-closing smoke and draft control assemblies having a fire protection rating of not less than 1 hour. Rooms shall have not less than one exterior wall that is provided with not less than two vents. Each vent shall have a minimum free opening area of 36 square inches (232 cm²) for each 1,000 cubic feet (28 m³) at normal temperature and pressure (NTP) of gas stored in the room and shall be not less than 72 square inches (465 cm²) in aggregate free opening area. One vent shall be within 6 inches (152 mm) of the floor and one shall be within 6 inches (152 mm) of the ceiling. Rooms shall be provided with not less than one automatic sprinkler to provide container cooling in case of fire.

440.9.1.2 One-hour interior room. Where an exterior wall cannot be provided for the room, a 1-hour interior room shall be provided and shall be a room or enclosure separated from the remainder of the building by fire barriers constructed in accordance with Section 707 or horizontal assemblies constructed in accordance with Section 711, or both, with a fire-resistance rating of not less than 1 hour. Openings between the room or enclosure and interior spaces shall be self-closing, smoke- and draft-control assemblies having a fire protection rating of not less than 1 hour. An automatic sprinkler system shall be installed within the room. The room shall be exhausted through a duct to the exterior. Supply and exhaust ducts shall be enclosed in a 1-hour-rated shaft enclosure from the room to the exterior. Approved mechanical ventilation shall comply with the Mechanical Code and be provided at a minimum rate of 1 cfm per square foot

[0.00508 m³/(s × m²)] of the area of the room.

440.9.1.3 Gas cabinets. Gas cabinets shall be constructed in accordance with Section 414.13 and shall comply with the following:

1. Exhausted to the exterior through dedicated exhaust duct system installed in accordance with Chapter 5 of the Mechanical Code.
2. Supply and exhaust ducts shall be enclosed in a 1-hour fire-resistance-rated shaft enclosure from the cabinet to the exterior. The average velocity of ventilation at the face of access ports or windows shall be not less than 200 feet per minute (1.02 m/s) with not less than 150 feet per minute (0.76 m/s) at any point of the access port or window.
3. Provided with an automatic sprinkler system internal to the cabinet.

440.9.2 Medical gas systems. Medical gas systems, including but not limited to supply manifolds, connections, pressure regulators, and relief devices and valves, shall be installed in accordance with NFPA 99 and the general provisions of this section. Existing medical gas systems shall be maintained in accordance with the maintenance, inspection and testing provisions of NFPA 99 for medical gas systems.

440.10 Compressed gases not otherwise regulated. Compressed gases in storage or use not regulated by the material-specific provisions of Sections 441, 442, and 447 through 454, including asphyxiant, irritant and radioactive gases, shall comply with this section in addition to other requirements of this section.

440.10.1 Carbon dioxide enrichment systems. The design, installation and maintenance of carbon dioxide enrichment systems with more than 100 pounds (45.4 kg) of carbon dioxide, and carbon dioxide enrichment systems with any quantity of carbon dioxide having a remote fill connection, shall comply with Sections 440.10.1.1 through 440.10.1.7.

440.10.1.1 Documentation. The following information shall be provided with the application for permit:

1. Total aggregate quantity of liquid carbon dioxide in pounds or cubic feet at NTP.
2. Location and total volume of the room where the carbon dioxide enrichment operation will be conducted. Identify whether the room is at grade or below grade.
3. Location of containers relative to equipment, building openings and means of egress.
4. Manufacturer's specifications and pressure rating, including cut sheets, of all piping and tubing to be used.
5. A piping and instrumentation diagram that shows piping support and remote-fill connections.

6. Details of *container* venting, including but not limited to vent line size, material and termination location.
7. Alarm and detection system and equipment, if applicable.
8. Seismic support for *containers*.

440.10.1.2 Equipment. The storage, use and handling of the carbon dioxide shall be in accordance with Section 440 and NFPA 55.

440.10.1.3 Gas detection system. A gas detection system complying with Section 916 shall be provided in rooms or indoor areas in which the carbon dioxide enrichment process is located, in rooms or indoor areas in which *container* systems are located, and in other areas where carbon dioxide is expected to accumulate. Carbon dioxide sensors shall be provided within 12 inches (305 mm) of the floor in the area where the gas is expected to accumulate or leaks are most likely to occur. The system shall be designed as follows:

1. Activates a low-level alarm upon detection of a carbon dioxide concentration of 5,000 ppm (9000 mg/m³).
2. Activates a high-level alarm upon detection of a carbon dioxide concentration of 30,000 ppm (54,000 mg/m³).

440.10.1.3.1 System activation. Activation of the low-level gas detection system alarm shall automatically:

1. Stop the flow of carbon dioxide to the piping system.
2. Activate the mechanical exhaust ventilation system.
3. Activate an audible and visible supervisory alarm signal at an *approved* location within the building.

Activation of the high-level gas detection system alarm shall automatically:

1. Stop the flow of carbon dioxide to the piping system.
2. Activate the mechanical exhaust ventilation system.
3. Activate an audible and visible evacuation alarm both inside and outside the carbon dioxide enrichment area, and the area in which the carbon dioxide *containers* are located.

440.10.1.4 Pressurization and ventilation. Rooms or indoor areas in which carbon dioxide enrichment is provided shall be maintained at a negative pressure in relation to the surrounding areas in the building. A mechanical ventilation system shall be provided in accordance with the *Mechanical Code* that complies with all of the following:

1. Mechanical ventilation in the room or area shall be at a rate of not less than 1 cfm per square foot [0.00508 m³/(s • m²)].
2. When activated by the gas detection system, the mechanical ventilation system shall remain on until manually reset.
3. The exhaust system intakes shall be taken from points within 12 inches (305 mm) of the floor.
4. The ventilation system shall discharge to the outdoors in an *approved* location.

440.10.1.5 Signage. Hazard identification signs shall be posted at the entrance to the room and indoor areas where the carbon dioxide enrichment process is located, and at the entrance to the room or indoor area where the carbon dioxide *containers* are located. The sign shall be not less than 8 inches (200 mm) in width and 6 inches (150 mm) in height and indicate: CAUTION – CARBON DIOXIDE GAS VENTILATE THE AREA BEFORE ENTERING. A HIGH CARBON DIOXIDE (CO₂) GAS CONCENTRATION IN THIS AREA CAN CAUSE ASPHYXIATION.

440.10.1.6 Seismic and structural design. Carbon dioxide system *containers* and piping shall comply with the seismic design requirements in Chapter 16 and shall not exceed the floor loading limitation of the building.

440.10.1.7 Container refilling. Carbon dioxide *containers* located indoors shall not be refilled unless filled from a remote connection located outdoors.

Section 441 Corrosive Materials

OSSC 441

441.1 Scope. The storage and use of *corrosive* materials shall be in accordance with this section. *Compressed gases* shall also comply with Section 440.

Exceptions:

1. Display and storage in Group M and storage in Group S occupancies complying with Section 414.2.5.
2. This section shall not apply to R-717 (ammonia) where used as a *refrigerant* in a *refrigeration system* (see Chapter 28).

441.2 Quantities not exceeding the maximum allowable quantity per control area. The storage and use of *corrosive* materials in amounts not exceeding the *maximum allowable quantity per control area* indicated in Section 307.1 shall be in accordance with Sections 414 and 441.

441.3 Quantities exceeding the maximum allowable quantity per control area. The storage and use of *corrosive* materials in amounts exceeding the *maximum allowable quantity per control area* indicated in Section 307.1 shall be in accordance with this section and Sections 414 and 415.

441.4 Indoor storage. Indoor storage of *corrosive* materials in amounts exceeding the *maximum allowable quantity per control area* indicated in Table 307.1(2) shall be in accordance with Sections 414 and 415 and this section.

441.4.1 Liquid-tight floor. In addition to the provisions of Section 415.12.8, floors in storage areas for *corrosive* liquids shall be of liquid-tight construction.

441.5 Indoor use. The indoor use of *corrosive* materials in amounts exceeding the *maximum allowable quantity per control area* indicated in Table 307.1(2) shall be in accordance with Sections 414 and 415 and this section.

441.5.1 Liquid transfer. *Corrosive* liquids shall be transferred in accordance with Section 415.13.10.

441.5.2 Ventilation. Where *corrosive* materials are dispensed or used, mechanical exhaust ventilation in accordance with Section 415.13.12.1.1 shall be provided.

Section 442 Cryogenic Fluids

OSSC 442

442.1 Scope. Storage, use and handling of *cryogenic fluids* shall comply with this section and NFPA 55. *Cryogenic fluids* classified as *hazardous materials* shall also comply with the general requirements of Sections 414 and 415. Partially full *containers* containing residual *cryogenic fluids* shall be considered as full for the purposes of the controls required.

Exceptions:

1. Fluids used as *refrigerants* in *refrigeration systems* (see Chapter 28).
2. Liquefied natural gas (LNG), which shall comply with NFPA 59A. Oxidizing *cryogenic fluids*, including oxygen, shall comply with Section 450, as applicable.

Flammable cryogenic fluids, including hydrogen, methane and carbon monoxide, shall comply with Sections 406 and 445, as applicable.

Inert cryogenic fluids, including argon, helium and nitrogen, shall comply with ANSI/CGA P-18.

442.2 Containers. *Containers* employed for storage and use of *cryogenic fluids* shall comply with Sections 442.2.1 through 442.2.2.2.

442.2.1 Concrete containers. Concrete *containers* shall be built in accordance with this code. Barrier materials and membranes used in connection with concrete, but not functioning structurally, shall be compatible with the materials contained.

442.2.2 Foundations and supports. *Containers* shall be provided with substantial concrete or masonry foundations, or structural steel supports on firm concrete or masonry foundations. *Containers* shall be supported to prevent the concentration of excessive loads on the supporting portion of the shell. Foundations for horizontal *containers* shall be constructed to accommodate expansion and contraction of the *containers*. Foundations shall be provided to support the weight of vaporizers or heat exchangers.

442.2.2.1 Temperature effects. Where *container* foundations or supports are subject to exposure to temperatures below -130°F (-90°C), the foundations or supports shall be constructed of materials to withstand the low-temperature effects of *cryogenic fluid* spillage.

442.2.2.2 Corrosion protection. Portions of *containers* in contact with foundations or saddles shall be painted to protect against corrosion.

442.3 Pressure relief vent piping. Pressure relief vent piping systems shall be constructed and arranged so as to remain functional and direct the flow of gas to a safe location in accordance with Sections 442.3.1 and 442.3.2.

442.3.1 Sizing. Pressure relief device vent piping shall have a cross-sectional area not less than that of the pressure relief device vent opening and shall be arranged so as not to restrict the flow of escaping gas.

442.3.2 Arrangement. Pressure relief device vent piping and drains in vent lines shall be arranged so that escaping gas will discharge unobstructed to the open air and not impinge on personnel, *containers*, equipment and adjacent structures or enter enclosed spaces. Pressure relief device vent lines shall be installed in such a manner to exclude or remove moisture and condensation and prevent malfunction of the pressure relief device because of freezing or ice accumulation.

442.4 Marking. *Cryogenic containers* and systems shall be marked in accordance with Sections 442.4.1 through 442.4.4.

442.4.1 Identification signs. Visible hazard identification signs in accordance with NFPA 704 shall be provided at entrances to buildings or areas in which *cryogenic fluids* are stored, handled or used.

442.4.2 Identification of contents. Stationary and portable *containers* shall be marked with the name of the gas contained. Stationary above-ground *containers* shall be placarded in accordance with Sections 414.8 and 414.9. Portable *containers* shall be identified in accordance with CGA C-7.

442.4.3 Identification of container connections. *Container* inlet and outlet connections, liquid-level limit controls, valves and pressure gauges shall be identified with one of the following:

1. A permanent tag or label identifying the function.
2. A schematic drawing that portrays the function and designates whether the connection is to the vapor or liquid space of the *container*.

Where a schematic drawing is provided, it shall be attached to the *container*.

442.4.4 Identification of emergency shutoff valves. *Emergency shutoff valves* shall be identified, and the location shall be clearly visible and indicated by means of a sign.

442.5 Security. *Cryogenic containers* and systems shall be secured against accidental dislodgement and against access by unauthorized personnel in accordance with Sections 442.5.1 through 442.5.4.

442.5.1 Security of areas. *Containers* and systems shall be secured against unauthorized entry and safeguarded in an *approved* manner.

442.5.2 Securing of containers. Stationary *containers* shall be secured to foundations in accordance with this code. Portable *containers* subject to shifting or upset shall be secured. Nesting shall be an acceptable means of securing *containers*.

442.5.3 Securing of vaporizers. Vaporizers, heat exchangers and similar equipment shall be anchored to a suitable foundation and its connecting piping shall be sufficiently flexible to provide for the effects of expansion and contraction due to temperature changes.

442.5.4 Physical protection. Containers, piping, valves, pressure relief devices, regulating equipment and other appurtenances shall be protected against physical damage and tampering.

442.6 Electrical wiring and equipment. Electrical wiring and equipment shall comply with the *Electrical Code* and Sections 442.6.1 and 442.6.2.

442.6.1 Location. *Containers* and systems shall not be located where they could become part of an electrical circuit.

442.6.2 Electrical grounding and bonding. *Containers* and systems shall not be used for electrical grounding. Where electrical grounding and bonding is required, the system shall comply with the *Electrical Code*. The grounding system shall be protected against corrosion, including corrosion caused by stray electric currents.

442.7 Lighting. Where required, lighting, including emergency lighting, shall be provided for fire appliances and operating facilities such as walkways, control valves and gates ancillary to stationary *containers*.

442.8 Indoor storage. Indoor storage of *containers* shall be in accordance with Sections 442.8.1 through 442.8.2.3.

442.8.1 Stationary containers. Stationary *containers* shall be installed in accordance with the provisions applicable to the type of fluid stored and this section.

442.8.1.1 Containers. Stationary *containers* shall comply with Section 442.2.

442.8.1.2 Construction of indoor areas. *Cryogenic fluids* in stationary *containers* stored indoors shall be located in buildings, rooms or areas constructed in accordance with this code.

442.8.1.3 Ventilation. Storage areas for stationary *containers* shall be ventilated in accordance with the *Mechanical Code*.

442.8.2 Portable containers. Indoor storage of portable *containers* shall comply with the provisions applicable to the type of fluid stored and Sections 442.8.2.1 through 442.8.2.3.

442.8.2.1 Containers. Portable *containers* shall comply with Section 442.2.

442.8.2.2 Construction of indoor areas. *Cryogenic fluids* in portable *containers* stored indoors shall be stored in buildings, rooms or areas constructed in accordance with this code.

442.8.2.3 Ventilation. Storage areas shall be ventilated in accordance with the *Mechanical Code*.

442.9 Use and handling. Use and handling of *cryogenic fluid containers* and systems shall comply with Sections 442.9.1 through 442.9.6.

442.9.1 Cryogenic fluid systems. *Cryogenic fluid* systems shall be suitable for the use intended and designed by persons competent in such design. Equipment, machinery and processes shall be *listed* or *approved*.

442.9.2 Indoor use. Indoor use of *cryogenic fluids* shall comply with the material-specific provisions of Section 442.1.

442.9.3 Filling and dispensing. Filling and dispensing of *cryogenic fluids* shall comply with Sections 442.9.3.1 through 442.9.6.

442.9.3.1 Dispensing areas. Dispensing of *cryogenic fluids* with physical or health hazards shall be conducted in *approved* locations. Dispensing indoors shall be conducted in areas constructed in accordance with this code.

442.9.4 Ventilation. Indoor areas where *cryogenic fluids* are dispensed shall be ventilated in accordance with the requirements of the *Mechanical Code* in a manner that captures any vapor at the point of generation.

Exception: *Cryogenic fluids* that can be demonstrated not to create harmful vapors.

442.9.5 Vehicle loading and unloading areas. Loading or unloading areas shall be conducted in an *approved* manner in accordance with the standards referenced in Section 442.1.

442.9.6 Limit controls. Limit controls shall be provided to prevent overfilling of *stationary containers* during filling operations.

Section 443 Explosives and Fireworks**OSSC 443**

443.1 Scope. The provisions of this section shall govern the manufacture, storage, and handling of *explosives, explosive materials, fireworks and small arms ammunition.*

Exceptions:

1. The Armed Forces of the United States, Coast Guard or National Guard.
2. *Explosives* in forms prescribed by the official United States Pharmacopoeia.
3. The possession, storage and use of small arms ammunition where packaged in accordance with DOTn packaging requirements.
4. The possession, storage and use of not more than 1 pound (0.454 kg) of commercially manufactured sporting black powder, 20 pounds (9 kg) of smokeless powder and 10,000 small arms primers for hand loading of small arms ammunition for personal consumption.
5. The use of *explosive materials* by federal, state and local regulatory, law enforcement and fire agencies acting in their official capacities.
6. Special industrial *explosive* devices that in the aggregate contain less than 50 pounds (23 kg) of *explosive materials*.
7. The possession, storage and use of blank industrial-power load cartridges where packaged in accordance with DOTn packaging regulations.
8. Transportation in accordance with DOTn 49 CFR Parts 100-185.
9. Items preempted by federal regulations.

443.2 General. The manufacture, assembly and testing of *explosives, ammunition, blasting agents and fireworks* shall comply with the requirements of this section and NFPA 495 or NFPA 1124.

Exceptions:

1. The hand loading of small arms ammunition prepared for personal use and not offered for resale.
2. The mixing and loading of blasting agents at blasting sites in accordance with NFPA 495.
3. The use of binary *explosives* or phosphoric materials in blasting or pyrotechnic special effects applications in accordance with NFPA 495 or NFPA 1126.

443.2.1 Intraplant separation of operating buildings. *Explosives* manufacturing buildings and fireworks manufacturing buildings, including those where *explosive* charges are assembled, manufactured, prepared or loaded utilizing Division 1.1, 1.2, 1.3, 1.4 or 1.5

explosives, shall be separated from all other buildings, including *magazines*, within the confines of the manufacturing plant at a distance not less than those shown in Table 443.2.1(1) or 443.2.1(4), as appropriate.

The quantity of *explosives* in an operating building shall be the net weight of all *explosives* contained therein. Distances shall be based on the hazard division requiring the greatest separation, unless the aggregate *explosive* weight is divided by *approved* walls or shields designed for that purpose. Where dividing a quantity of *explosives* into smaller stacks, a suitable barrier or adequate separation distance shall be provided to prevent propagation from one stack to another.

Where distance is used as the sole means of separation within a building, such distance shall be established by testing. Testing shall demonstrate that propagation between stacks will not result. Barriers provided to protect against *explosive* effects shall be designed and installed in accordance with *approved* standards.

Exception: Fireworks manufacturing buildings separated in accordance with NFPA 1124.

443.2.2 Separation of manufacturing operating buildings from inhabited buildings, public traffic routes and magazines. Where an operating building on an *explosive materials* plant site is designed to contain *explosive materials*, such a building shall be located away from *inhabited buildings, public traffic routes and magazines* in accordance with Table 443.2.1(3) or 443.2.1(4), as appropriate, based on the maximum quantity of *explosive materials* permitted to be in the building at one time.

Exception: Fireworks manufacturing buildings constructed and operated in accordance with NFPA 1124.

443.2.3 Buildings and equipment. Buildings or rooms that exceed the *maximum allowable quantity per control area of explosive materials* shall be operated in accordance with this section and constructed in accordance with the requirements of this code for Group H occupancies.

Exception: Fireworks manufacturing buildings constructed and operated in accordance with NFPA 1124.

443.2.3.1 Explosives dust. *Explosives* dust shall not be exhausted to the atmosphere.

443.2.3.1.1 Wet collector. When collecting *explosives* dust, a wet collector system shall be used. Wetting agents shall be compatible with the *explosives*. Collector systems shall be interlocked with process power supplies so that the process cannot continue without the collector systems operating.

TABLE 443.2.1(1)
MINIMUM INTRALINE (INTRAPLANT) SEPARATION DISTANCES (ILD OR IPD) BETWEEN BARRICADED OPERATING BUILDINGS CONTAINING EXPLOSIVES—DIVISION 1.1, 1.2 OR 1.5 MASS-EXPLOSION HAZARD^a

NET EXPLOSIVE WEIGHT			NET EXPLOSIVE WEIGHT		
Pounds over	Pounds not over	Intraline Distance (ILD) or Intraplant Distance (IPD) (feet)	Pounds over	Pounds not over	Intraline Distance (ILD) or Intraplant Distance (IPD) (feet)
0	50	30	20,000	25,000	265
50	100	40	25,000	30,000	280
100	200	50	30,000	35,000	295
200	300	60	35,000	40,000	310
300	400	65	40,000	45,000	320
400	500	70	45,000	50,000	330
500	600	75	50,000	55,000	340
600	700	80	55,000	60,000	350
700	800	85	60,000	65,000	360
800	900	90	65,000	70,000	370
900	1,000	95	70,000	75,000	385
1,000	1,500	105	75,000	80,000	390
1,500	2,000	115	80,000	85,000	395
2,000	3,000	130	85,000	90,000	400
3,000	4,000	140	90,000	95,000	410
4,000	5,000	150	95,000	100,000	415
5,000	6,000	160	100,000	125,000	450
6,000	7,000	170	125,000	150,000	475
7,000	8,000	180	150,000	175,000	500
8,000	9,000	190	175,000	200,000	525
9,000	10,000	200	200,000	225,000	550
10,000	15,000	225	225,000	250,000	575
15,000	20,000	245	250,000	275,000	600
---	---	---	275,000	300,000	635

For SI: 1 foot = 304.8 mm, 1 pound = 0.454 kg.

a. Where a building or magazine containing explosives is not barricaded, the intraline distances shown in this table shall be doubled.

**TABLE 443.2.1(2)
AMERICAN TABLE OF DISTANCES FOR STORAGE OF EXPLOSIVES AS APPROVED BY THE INSTITUTE OF MAKERS OF
EXPLOSIVES AND REVISED JUNE 1991^a**

QUANTITY OF EXPLOSIVE MATERIALS:		DISTANCES IN FEET							
		Inhabited buildings		Public highways with traffic volume less than 3,000 vehicles per day		Public highways with traffic volume greater than 3,000 vehicles per day and passenger railroads		Separation of magazines ^d	
Pounds over	Pounds not over	Barricaded	Unbarricaded	Barricaded	Unbarricaded	Barricaded	Unbarricaded	Barricaded	Unbarricaded
0	5	70	140	30	60	51	102	6	12
5	10	90	180	35	70	64	128	8	16
10	20	110	220	45	90	81	162	10	20
20	30	125	250	50	100	93	186	11	22
30	40	140	280	55	110	103	206	12	24
40	50	150	300	60	120	110	220	14	28
50	75	170	340	70	140	127	254	15	30
75	100	190	380	75	150	139	278	16	32
100	125	200	400	80	160	150	300	18	36
125	150	215	430	85	170	159	318	19	38
150	200	235	470	95	190	175	350	21	42
200	250	255	510	105	210	189	378	23	46
250	300	270	540	110	220	201	402	24	48
300	400	295	590	120	240	221	442	27	54
400	500	320	640	130	260	238	476	29	58
500	600	340	680	135	270	253	506	31	62
600	700	355	710	145	290	266	532	32	64
700	800	375	750	150	300	278	556	33	66
800	900	390	780	155	310	289	578	35	70
900	1,000	400	800	160	320	300	600	36	72
1,000	1,200	425	850	165	330	318	636	39	78
1,200	1,400	450	900	170	340	336	672	41	82
1,400	1,600	470	940	175	350	351	702	43	86
1,600	1,800	490	980	180	360	366	732	44	88
1,800	2,000	505	1,010	185	370	378	756	45	90
2,000	2,500	545	1,090	190	380	408	816	49	98
2,500	3,000	580	1,160	195	390	432	864	52	104
3,000	4,000	635	1,270	210	420	474	948	58	116
4,000	5,000	685	1,370	225	450	513	1,026	61	122
5,000	6,000	730	1,460	235	470	546	1,092	65	130
6,000	7,000	770	1,540	245	490	573	1,146	68	136
7,000	8,000	800	1,600	250	500	600	1,200	72	144
8,000	9,000	835	1,670	255	510	624	1,248	75	150
9,000	10,000	865	1,730	260	520	645	1,290	78	156
10,000	12,000	875	1,750	270	540	687	1,374	82	164
12,000	14,000	885	1,770	275	550	723	1,446	87	174
14,000	16,000	900	1,800	280	560	756	1,512	90	180
16,000	18,000	940	1,880	285	570	786	1,572	94	188
18,000	20,000	975	1,950	290	580	813	1,626	98	196
20,000	25,000	1,055	2,000	315	630	876	1,752	105	210

(continued)

TABLE 443.2.1(2)—continued

AMERICAN TABLE OF DISTANCES FOR STORAGE OF EXPLOSIVES AS APPROVED BY THE INSTITUTE OF MAKERS OF EXPLOSIVES AND REVISED JUNE 1991^a

QUANTITY OF EXPLOSIVE MATERIALS:		DISTANCES IN FEET							
		Inhabited buildings		Public highways with traffic volume less than 3,000 vehicles per day		Public highways with traffic volume greater than 3,000 vehicles per day and passenger railways		Separation of magazines ^d	
Pounds over	Pounds not over	Barricaded	Unbarricaded	Barricaded	Unbarricaded	Barricaded	Unbarricaded	Barricaded	Unbarricaded
25,000	30,000	1,130	2,000	340	680	933	1,866	112	224
30,000	35,000	1,205	2,000	360	720	981	1,962	119	238
35,000	40,000	1,275	2,000	380	760	1,026	2,000	124	248
40,000	45,000	1,340	2,000	400	800	1,068	2,000	129	258
45,000	50,000	1,400	2,000	420	840	1,104	2,000	135	270
50,000	55,000	1,460	2,000	440	880	1,140	2,000	140	280
55,000	60,000	1,515	2,000	455	910	1,173	2,000	145	290
60,000	65,000	1,565	2,000	470	940	1,206	2,000	150	300
65,000	70,000	1,610	2,000	485	970	1,236	2,000	155	310
70,000	75,000	1,655	2,000	500	1,000	1,263	2,000	160	320
75,000	80,000	1,695	2,000	510	1,020	1,293	2,000	165	330
80,000	85,000	1,730	2,000	520	1,040	1,317	2,000	170	340
85,000	90,000	1,760	2,000	530	1,060	1,344	2,000	175	350
90,000	95,000	1,790	2,000	540	1,080	1,368	2,000	180	360
95,000	100,000	1,815	2,000	545	1,090	1,392	2,000	185	370
100,000	110,000	1,835	2,000	550	1,100	1,437	2,000	195	390
110,000	120,000	1,855	2,000	555	1,110	1,479	2,000	205	410
120,000	130,000	1,875	2,000	560	1,120	1,521	2,000	215	430
130,000	140,000	1,890	2,000	565	1,130	1,557	2,000	225	450
140,000	150,000	1,900	2,000	570	1,140	1,593	2,000	235	470
150,000	160,000	1,935	2,000	580	1,160	1,629	2,000	245	490
160,000	170,000	1,965	2,000	590	1,180	1,662	2,000	255	510
170,000	180,000	1,990	2,000	600	1,200	1,695	2,000	265	530
180,000	190,000	2,010	2,010	605	1,210	1,725	2,000	275	550
190,000	200,000	2,030	2,030	610	1,220	1,755	2,000	285	570
200,000	210,000	2,055	2,055	620	1,240	1,782	2,000	295	590
210,000	230,000	2,100	2,100	635	1,270	1,836	2,000	315	630
230,000	250,000	2,155	2,155	650	1,300	1,890	2,000	335	670
250,000	275,000	2,215	2,215	670	1,340	1,950	2,000	360	720
275,000	300,000 ^b	2,275	2,275	690	1,380	2,000	2,000	385	770

For SI: 1 foot = 304.8 mm, 1 pound = 0.454 kg.

- a. This table applies only to the manufacture and permanent storage of commercial explosive materials. It is not applicable to transportation of explosives or any handling or temporary storage necessary or incident thereto. It is not intended to apply to bombs, projectiles or other heavily encased explosives.
- b. Storage in excess of 300,000 pounds of explosive materials in one magazine is not allowed.
- c. Where a manufacturing building on an explosive materials plant site is designed to contain explosive materials, such building shall be located with respect to its proximity to inhabited buildings, public highways and passenger railways based on the maximum quantity of explosive materials permitted to be in the building at one time.
- d. Where two or more storage magazines are located on the same property, each magazine shall comply with the minimum distances specified from inhabited buildings, railways and highways, and, in addition, they should be separated from each other by not less than the distances shown for separation of magazines, except that the quantity of explosives in detonator magazines shall govern in regard to the spacing of said detonator magazines from magazines containing other explosive materials. Where any two or more magazines are separated from each other by less than the specified separation of magazines distances, then two or more such magazines, as a group, shall be considered as one magazine, and the total quantity of explosive materials stored in such group shall be treated as if stored in a single magazine located on the site of any magazine in the group and shall comply with the minimum distances specified from other magazines, inhabited buildings, railways and highways.

TABLE 443.2.1(3)
TABLE OF DISTANCES (Q-D) FOR BUILDINGS AND MAGAZINES CONTAINING EXPLOSIVES—DIVISION 1.3 MASS-FIRE HAZARD^{a, b, c}

QUANTITY OF DIVISION 1.3 EXPLOSIVES (NET EXPLOSIVES WEIGHT)		DISTANCES IN FEET			
Pounds over	Pounds not over	Inhabited Building Distance (IBD)	Distance to Public Traffic Route (PTR)	Intermagazine Distance (IMD)	Intraline Distance (ILD) or Intraplant Distance (IPD)
0	1,000	75	75	50	50
1,000	5,000	115	115	75	75
5,000	10,000	150	150	100	100
10,000	20,000	190	190	125	125
20,000	30,000	215	215	145	145
30,000	40,000	235	235	155	155
40,000	50,000	250	250	165	165
50,000	60,000	260	260	175	175
60,000	70,000	270	270	185	185
70,000	80,000	280	280	190	190
80,000	90,000	295	295	195	195
90,000	100,000	300	300	200	200
100,000	200,000	375	375	250	250
200,000	300,000	450	450	300	300

For SI: 1 foot = 304.8 mm, 1 pound = 0.454 kg

- a. Black powder, when stored in magazines, is defined as low explosive by the Bureau of Alcohol, Tobacco, Firearms and Explosives (BATF).
- b. For quantities less than 1,000 pounds, the required distances are those specified for 1,000 pounds. The use of lesser distances is allowed where supported by approved test data or analysis.
- c. Linear interpolation of explosive quantities between table entries is allowed.

TABLE 443.2.1(4)
TABLE OF DISTANCES (Q-D) FOR BUILDINGS AND MAGAZINES CONTAINING EXPLOSIVES—DIVISION 1.4^c

QUANTITY OF DIVISION 1.4 EXPLOSIVES (NET EXPLOSIVES WEIGHT)		DISTANCES IN FEET			
Pounds over	Pounds not over	Inhabited Building Distance (IBD)	Distance to Public Traffic Route (PTR)	Intermagazine Distance ^a (IMD)	Intraline Distance (ILD) or Intraplant Distance ^a (IPD)
50	Not Limited	100	100	50	50

For SI: 1 foot = 304.8 mm, 1 pound = 0.454 kg.

- a. A separation distance of 100 feet is required for buildings of other than Type I or Type II construction as defined in this code.
- b. For earth-covered magazines, specific separation is not required.
 - 1. Earth cover material used for magazines shall be relatively cohesive. Solid or wet clay and similar types of soil are too cohesive and shall not be used. Soil shall be free from unsanitary organic matter, trash, debris and stones heavier than 10 pounds or larger than 6 inches in diameter. Compaction and surface preparation shall be provided, as necessary, to maintain structural integrity and avoid erosion. Where cohesive material cannot be used, as in sandy soil, the earth cover over magazines shall be finished with a suitable material to ensure structural integrity.
 - 2. The earth fill or earth cover between earth-covered magazines shall be either solid or sloped, in accordance with the requirements of other construction features, but not less than 2 feet of earth cover shall be maintained over the top of each magazine. To reduce erosion and facilitate maintenance operations, the cover shall have a slope of 1 vertical to 2 horizontal.
- c. Restricted to articles, including articles packaged for shipment, that are not regulated as an explosive under Bureau of Alcohol, Tobacco, Firearms and Explosives regulations, or unpacked articles used in process operations that do not propagate a detonation or deflagration between articles.

443.2.3.2 Exhaust fans. Squirrel cage blowers shall not be used for exhausting hazardous fumes, vapors or gases. Only nonferrous fan blades shall be used for fans located within the ductwork and through which hazardous materials are exhausted. Motors shall be located outside the duct.

443.2.3.3 Workstations. Workstations shall be separated by distance, barrier or other approved alternatives so that fire in one station will not ignite

material in another workstation. Where necessary, the operator shall be protected by a personnel shield located between the operator and the explosive device or explosive material being processed. This shield and its support shall be capable of withstanding a blast from the maximum amount of explosives allowed behind it.

443.3 Small arms ammunition and small arms ammunition components. Indoor storage and display of black powder, smokeless *propellants*, small arms primers and small arms ammunition and commercial reloading shall comply with this section and NFPA 495.

443.3.1 Prohibited storage. Small arms ammunition shall not be stored together with Division 1.1, Division 1.2 or Division 1.3 *explosives* unless the storage facility is suitable for the storage of *explosive materials*.

443.3.2 Packages. Smokeless *propellants* shall be stored in *approved shipping containers* conforming to DOTn 49 CFR Part 173.

443.3.2.1 Repackaging. The bulk repackaging of smokeless *propellants*, black powder and small arms primers shall not be performed in retail establishments.

443.3.2.2 Damaged packages. Damaged *containers* shall not be repackaged.

Exception: *Approved* repackaging of damaged *containers* of smokeless *propellant* into *containers* of the same type and size as the original *container*.

443.3.3 Storage in Group R occupancies. The storage of small arms ammunition components in Group R occupancies shall comply with Sections 443.3.3.1 through 443.3.3.3.

443.3.3.1 Black powder. Black powder for personal use in quantities not exceeding 20 pounds (9 kg) shall be stored in original *containers* in occupancies limited to Group R-3. Quantities exceeding 20 pounds (9 kg) shall not be stored in any Group R occupancy.

443.3.3.2 Smokeless propellants. Smokeless *propellants* for personal use in quantities not exceeding 20 pounds (9 kg) shall be stored in original *containers* in occupancies limited to Group R-3. Smokeless *propellants* in quantities exceeding 20 pounds (9 kg) but not exceeding 50 pounds (23 kg) and kept in a wooden box or cabinet having walls of not less than 1 inch (25 mm) nominal thickness shall be allowed to be stored in occupancies limited to Group R-3. Quantities exceeding these amounts shall not be stored in any Group R occupancy.

443.3.3.3 Small arms primers. Not more than 10,000 small arms primers shall be stored in occupancies limited to Group R-3.

443.3.4 Display and storage in Group M occupancies. The display and storage of small arms ammunition components in Group M occupancies shall comply with Sections 443.3.4.1 through 443.3.4.2.3.

443.3.4.1 Display. Display of small arms ammunition components in Group M occupancies shall comply with Sections 443.3.4.1.1 through 443.3.4.1.3.

443.3.4.1.1 Smokeless propellant. Not more than 20 pounds (9 kg) of smokeless *propellants* in *containers* of 1 pound (0.454 kg) or less capacity each, shall be displayed in Group M occupancies.

443.3.4.1.2 Black powder. Not more than 1 pound (0.454 kg) of black powder shall be displayed in Group M occupancies.

443.3.4.1.3 Small arms primers. Not more than 10,000 small arms primers shall be displayed in Group M occupancies.

443.3.4.2 Storage. Storage of small arms ammunition components shall comply with Sections 443.3.4.2.1 through 443.3.4.2.3.

443.3.4.2.1 Smokeless propellant. Commercial stocks of smokeless *propellants* shall be stored as follows:

1. Quantities exceeding 20 pounds (9 kg) but not exceeding 100 pounds (45 kg) shall be stored in portable wooden boxes having walls of not less than 1 inch (25 mm) nominal thickness.
2. Quantities exceeding 100 pounds (45 kg) but not exceeding 800 pounds (363 kg) shall be stored in nonportable storage cabinets having walls not less than 1 inch (25 mm) nominal thickness. Not more than 400 pounds (182 kg) shall be stored in any one cabinet, and cabinets shall be separated by a distance of not less than 25 feet (7620 mm) or by a *fire partition* having a *fire-resistance rating* of not less than 1 hour.
3. Storage of quantities exceeding 800 pounds (363 kg) but not exceeding 5,000 pounds (2270 kg) in a building shall comply with all of the following:
 - 3.1. The warehouse or storage room is not open to unauthorized personnel.
 - 3.2. Smokeless *propellant* shall be stored in nonportable storage cabinets having wood walls not less than 1 inch (25 mm) nominal thickness and having shelves with not more than 3 feet (914 mm) of separation between shelves.
 - 3.3. Not more than 400 pounds (182 kg) is stored in any one cabinet.
 - 3.4. Cabinets shall be located against walls of the storage room or warehouse with not less than 40 feet (12,192 mm) between cabinets.
 - 3.5. The minimum required separation between cabinets shall be 20 feet (6096 mm), provided that *barricades* twice the

height of the cabinets are attached to the wall, midway between each cabinet. The *barricades* must extend not less than 10 feet (3048 mm) outward, be firmly attached to the wall and be constructed of steel not less than 1/4 inch thick (6.4 mm), 2-inch (51 mm) nominal thickness wood, brick or concrete block.

3.6. Smokeless *propellant* shall be separated from materials classified as *combustible liquids*, flammable liquids, flammable solids or oxidizing materials by a distance of 25 feet (7620 mm) or by a *fire partition* having a *fire-resistance rating* of 1 hour.

3.7. The building shall be equipped throughout with an *automatic sprinkler system* installed in accordance with Section 903.3.1.1.

4. Smokeless *propellants* not stored in accordance with Item 1, 2, or 3 shall be stored in a Type 2 or 4 *magazine* in accordance with NFPA 495.

443.3.4.2.2 Black powder. Commercial stocks of black powder in quantities less than 50 pounds (23 kg) shall be allowed to be stored in Type 2 or 4 indoor or outdoor *magazines*. Quantities greater than 50 pounds (23 kg) shall be stored in outdoor Type 2 or 4 *magazines*. Where black powder and smokeless *propellants* are stored together in the same *magazine*, the total quantity shall not exceed that permitted for black powder.

443.3.4.2.3 Small arms primers. Commercial stocks of small arms primers shall be stored as follows:

1. Quantities not to exceed 750,000 small arms primers stored in a building shall be arranged such that not more than 100,000 small arms primers are stored in any one pile and piles are not less than 15 feet (4572 mm) apart.

2. Quantities exceeding 750,000 small arms primers stored in a building shall comply with all of the following:

2.1. The warehouse or storage building is not open to unauthorized personnel.

2.2. Small arms primers shall be stored in cabinets. Not more than 200,000 small arms primers shall be stored in any one cabinet.

2.3. Shelves in cabinets shall have vertical separation of not less than 2 feet (610 mm).

2.4. Cabinets shall be located against walls of the warehouse or storage room with not less than 40 feet (12192 mm) between cabinets. The minimum required separation between cabinets shall be allowed to be reduced to 20 feet (6096 mm) provided that *barricades* twice the height of the cabinets are attached to the wall, midway between each cabinet. The *barricades* shall be firmly attached to the wall and shall be constructed of steel not less than 1/4 inch thick (6.4 mm), 2-inch (51 mm) nominal thickness wood, brick or concrete block.

2.5. Small arms primers shall be separated from materials classified as *combustible liquids*, flammable liquids, flammable solids or oxidizing materials by a distance of 25 feet (7620 mm) or by a *fire partition* having a *fire-resistance rating* of 1 hour.

2.6. The building shall be protected throughout with an *automatic sprinkler system* installed in accordance with Section 903.3.1.1.

3. Small arms primers not stored in accordance with Item 1 or 2 of this section shall be stored in a *magazine* meeting the requirements of NFPA 495.

443.4 Commercial reloading. Commercial reloading of small arms ammunition shall comply with Sections 443.4.1 through 443.4.7.

443.4.1 Electrical. Areas within 3 feet (914 mm) of reloading equipment shall be Class I, Division 2, Group A type.

443.4.2 Exhaust fans. Squirrel cage blowers shall not be used for exhausting hazardous fumes, vapors or gases. Only nonferrous fan blades shall be used for fans located within the ductwork and through which hazardous materials are exhausted. Motors shall be located outside the duct.

443.4.3 Work stations. Work stations shall be separated by distance, barrier or other approved alternatives so that fire in one station will not ignite material in another work station.

443.4.4 Approved containers. Smokeless powder shall be kept in its original container.

443.4.5 Static controls. The work area shall be provided with approved static controls.

Section 444 Flammable and Combustible Liquids**OSSC 444**

444.1 Scope and application. Prevention, control and mitigation of dangerous conditions related to storage, use, dispensing, mixing and handling of flammable and *combustible liquids* shall be in accordance with Sections 414 and 415 and this section.

444.1.1 Nonapplicability. This section shall not apply to liquids as otherwise provided in other laws or regulations or chapters of this code, including:

1. Specific provisions for flammable liquids in motor fuel-dispensing facilities, repair garages, airports and marinas in Section 406.
2. Medicines, foodstuffs, cosmetics and commercial or institutional products containing not more than 50 percent by volume of water-miscible liquids and with the remainder of the solution not being flammable, provided that such materials are packaged in individual *containers* not exceeding 1.3 gallons (5 L).
3. Quantities of alcoholic beverages in retail or wholesale sales or storage occupancies, provided that the liquids are packaged in individual *containers* not exceeding 1.3 gallons (5 L).
4. Storage and use of fuel oil in tanks and *containers* connected to oil-burning equipment. Such storage and use shall be in accordance with Chapter 28. For abandonment of fuel oil tanks, this section applies.
5. Refrigeration systems (see Chapter 28).
6. Storage and display of aerosol products complying with Section 439.
7. Storage and use of liquids that do not have a fire point when tested in accordance with ASTM D92.
8. Liquids with a *flash point* greater than 95°F (35°C) in a water-miscible solution or dispersion with a water and inert (noncombustible) solids content of more than 80 percent by weight, which do not sustain combustion.
9. Liquids without *flash points* that can be flammable under some conditions, such as certain halogenated hydrocarbons and mixtures containing halogenated hydrocarbons.
10. The storage of beer, distilled spirits and wines in barrels and casks.
11. Commercial cooking oil storage tank systems located within a building and designed and installed in accordance with Section 444.9 and NFPA 30.

444.1.2 Material classification. Flammable and *combustible liquids* shall be classified in accordance with the definitions in Chapter 2.

When mixed with lower flash-point liquids, Class II or III liquids are capable of assuming the characteristics of the lower flash-point liquids. Under such conditions, the appropriate provisions of this section for the actual *flash point* of the mixed liquid shall apply.

When heated above their *flash points*, Class II and III liquids assume the characteristics of Class I liquids. Under such conditions, the appropriate provisions of this section for flammable liquids shall apply.

444.2 Electrical wiring and equipment. Electrical wiring and equipment shall be installed in accordance with Chapter 27 and the *Electrical Code*.

444.2.1 Classified locations for flammable liquids. Areas where flammable liquids are stored, handled, dispensed or mixed shall be in accordance with Table 444.2.1. A classified area shall not extend beyond an unpierced floor, roof or other solid partition.

The extent of the classified area is allowed to be reduced or eliminated where sufficient technical justification is provided to the *building official* that a concentration in the area in excess of 25 percent of the LFL cannot be generated.

444.2.2 Classified locations for combustible liquids. Areas where Class II or III liquids are heated above their *flash points* shall have electrical installations in accordance with Section 444.2.1.

Exception: *Solvent distillation units* in accordance with Section 444.5.3.

444.2.3 Other applications. The *building official* is authorized to determine the extent of the Class I electrical equipment and wiring location where a condition is not specifically covered by these requirements or the *Electrical Code*.

444.3 Fire protection. Fire protection for the storage, use, dispensing, mixing, handling and on-site transportation of flammable and *combustible liquids* shall be in accordance with this section and applicable sections of Chapter 9.

444.3.1 Protection from vehicles. Guard posts or other *approved* means shall be provided to protect piping, valves or fittings subject to vehicular damage in accordance with Section 912.4.4.

444.4 Storage. The storage of flammable and *combustible liquids* in *containers* and tanks inside buildings shall be in accordance with this section and the applicable provisions of Sections 414 and 415.

444.4.1 Tank storage. The provisions of this section shall apply to:

1. The storage of flammable and *combustible liquids* in fixed above-ground tanks.
2. The storage of flammable and *combustible liquids* in fixed above-ground tanks inside of buildings.
3. The storage of flammable and *combustible liquids* in *portable tanks* whose capacity exceeds 660 gallons (2498 L).
4. The installation of such tanks and *portable tanks*.

444.4.1.1 Change of tank contents. Tanks subject to change in contents shall be in accordance with Section 444.4.1.5. Prior to a change in contents, the *building official* is authorized to require testing of a tank.

Tanks that have previously contained Class I liquids shall not be loaded with Class II or Class III liquids until such tanks and all piping, pumps, hoses and meters connected thereto have been completely drained and flushed.

444.4.1.2 Labeling and signs. Labeling and signs for storage tanks and storage tank areas shall comply with Sections 444.4.1.2.1 and 444.4.1.2.2.

444.4.1.2.1 Smoking and open flame. Signs shall be posted in storage areas prohibiting open flames and smoking. Signs shall comply with Sections 414.8 through 414.10.1.

444.4.1.2.2 Label or placard. Tanks more than 100 gallons (379 L) in capacity, which are permanently installed or mounted and used for the storage of Class I, II or III liquids, shall bear a label and placard identifying the material therein. Placards shall be in accordance with NFPA 704.

Exceptions:

1. Tanks of 300-gallon (1136 L) capacity or less located on private property and used for heating and cooking fuels in single-family dwellings.
2. Tanks located underground.

444.4.1.3 Explosion control. Explosion control shall be provided in accordance with Section 919 for indoor tanks.

444.4.1.4 Separation from incompatible materials. Storage of flammable and *combustible liquids* shall be separated from *incompatible materials* in accordance with Section 414.19.

444.4.1.5 Design, fabrication and construction requirements for tanks. The design, fabrication and construction of tanks shall comply with NFPA 30. Each tank shall bear a permanent nameplate or marking indicating the standard used as the basis of design.

444.4.1.5.1 Materials used in tank construction. The materials used in tank construction shall be in accordance with NFPA 30. The materials of construction for tanks and their appurtenances shall be compatible with the liquids to be stored.

444.4.1.5.2 Pressure limitations for tanks. Tanks shall be designed for the pressures to which they will be subjected in accordance with NFPA 30.

444.4.1.5.3 Tank vents for normal venting. Tank vents for normal venting shall be installed and maintained in accordance with Sections 444.4.1.5.3.1 through 444.4.1.5.3.5.2.

444.4.1.5.3.1 Vent lines. Vent lines from tanks shall not be used for purposes other than venting unless *approved*.

444.4.1.5.3.2 Vent-line flame arresters and pressure-vacuum vents. *Listed or approved* flame arresters or pressure-vacuum (PV) vents that remain closed unless venting under pressure or vacuum conditions shall be installed in normal vents of tanks containing Class IB and IC liquids.

Vent-line flame arresters shall be installed in accordance with their listing or API 2000 and maintained in accordance with Section 21.8.6 of NFPA 30 or API 2000. Pressure-vacuum vents shall be installed in accordance with Section 21.4.3 of NFPA 30 or API 2000 and maintained in accordance with Section 21.8.6 of NFPA 30 or API 2000.

Exception: Where determined by the *building official* that the use of these devices can result in damage to the tank.

444.4.1.5.3.3 Vent pipe outlets. Vent pipe outlets for tanks storing Class I, II or IIIA liquids shall be located such that the vapors are released at a safe point outdoors and not less than 12 feet (3658 mm) above the finished ground level. Vapors shall be discharged upward or horizontally away from adjacent walls to assist in vapor dispersion. Vent outlets shall be located such that flammable vapors will not be trapped by eaves or other obstructions and shall be not less than 5 feet (1524 mm) from building openings or *lot lines* of properties that can be built on. Vent outlets on atmospheric tanks storing Class IIIB liquids are allowed to discharge inside a building where the vent is a normally closed vent.

Exception: Vent pipe outlets on tanks storing Class IIIB liquid inside buildings and connected to fuel-burning equipment shall be located such that the vapors are released to a safe location outdoors.

444.4.1.5.3.4 Installation of vent piping. Vent pipes shall be installed such that they will drain toward the tank without sags or traps in which liquid can collect. Vent pipes shall be installed in such a manner so as not to be subject to physical damage or vibration.

444.4.1.5.3.5 Manifolding. Tank vent piping shall not be manifolded unless required for special purposes such as vapor recovery, vapor conservation or air pollution control.

444.4.1.5.3.5.1 Above-ground tanks inside buildings. For above-ground tanks, manifolded vent pipes shall be adequately sized to prevent system pressure limits from being exceeded where manifolded tanks are subject to the same fire exposure.

444.4.1.5.3.5.2 Tanks storing Class I liquids. To prevent contamination and possible change in classification of less volatile liquid, vent piping for tanks storing Class I liquids shall not be manifolded with vent piping for tanks storing Class II and III liquids unless positive means are provided to prevent the vapors from Class I liquids from entering tanks storing Class II and III liquids.

444.4.1.5.4 Emergency venting. Stationary, aboveground tanks shall be equipped with additional venting that will relieve excessive internal pressure caused by exposure to fires. Emergency vents for Class I, II and IIIA liquids shall not discharge inside buildings. The venting shall be installed and maintained in accordance with Section 22.7 of NFPA 30.

Exceptions:

1. Tanks larger than 12,000 gallons (45 420 L) in capacity storing Class IIIB liquids that are not within the diked area or the drainage path of Class I or II liquids do not require emergency relief venting.
2. Emergency vents on protected aboveground tanks complying with UL 2085 containing Class II or IIIA liquids are allowed to discharge inside the building.

444.4.1.5.5 Tank openings other than vents. Tank openings for other than vents shall comply with Sections 444.4.1.5.5.1 through 444.4.1.5.5.7.

444.4.1.5.5.1 Connections below liquid level. Connections for tank openings below the liquid level shall be liquid tight.

444.4.1.5.5.2 Filling, emptying and vapor recovery connections. Filling, emptying and vapor recovery connections to tanks containing Class I, II or IIIA liquids shall be located outside buildings in accordance with Section

444.4.1.5.5.5 at a location free from sources of ignition and not less than 5 feet (1524 mm) from building openings or *lot lines* of property that can be built on. Such openings shall be properly identified and provided with a liquid-tight cap that shall be closed when not in use.

Filling and emptying connections to indoor tanks containing Class IIIB liquids and connected to fuel-burning equipment shall be located at a finished ground level location outdoors. Such openings shall be provided with a liquid-tight cap that shall be closed when not in use. A sign in accordance with Section 414.9 that displays the following warning shall be permanently attached at the filling location:

TRANSFERRING FUEL OTHER THAN CLASS IIIB COMBUSTIBLE LIQUID TO THIS TANK CONNECTION IS STRICTLY PROHIBITED

444.4.1.5.5.3 Manual gauging. Openings for manual gauging, if independent of the fill pipe, shall be provided with a liquid-tight cap or cover. Covers shall be kept closed when not gauging; such openings shall be protected against liquid overflow and possible vapor release by means of a spring-loaded check valve or other approved device.

444.4.1.5.5.4 Fill pipes and discharge lines. For top-loaded tanks, a metallic fill pipe shall be designed and installed to minimize the generation of static electricity by terminating the pipe within 6 inches (152 mm) of the bottom of the tank, and it shall be installed in a manner that avoids excessive vibration.

444.4.1.5.5.4.1 Class I liquids. For Class I liquids other than crude oil, gasoline and asphalt, the fill pipe shall be designed and installed in a manner that will minimize the possibility of generating static electricity by terminating within 6 inches (152 mm) of the bottom of the tank.

444.4.1.5.5.5 Location of connections that are made or broken. Filling, withdrawal and vaporrecovery connections for Class I, II and IIIA liquids that are made and broken shall be located outdoors, not more than 5 feet (1524 mm) above the finished ground level, in an approved location in close proximity to the parked delivery vehicle. Such location shall be away from sources of ignition and not less than 5 feet (1524 mm) from building openings. Such connections shall be closed and liquid tight when not in use and shall be properly identified.

444.4.1.5.5.6 Protection against vapor release. Tank openings provided for purposes of vapor recovery shall be protected against possible vapor release by means of a spring-loaded check

valve or dry-break connections, or other *approved* device, unless the opening is a pipe connected to a vapor processing system. Openings designed for combined fill and vapor recovery shall be protected against vapor release unless connection of the liquid delivery line to the fill pipe simultaneously connects the vapor recovery line. Connections shall be vapor tight.

444.4.1.5.7 Overfill prevention. An *approved* means or method in accordance with Section 444.4.1.7.5.5 shall be provided to prevent the overfill of all Class I, II and IIIA liquid storage tanks. Storage tanks in refineries, bulk plants or terminals regulated by Section 444.6 or 444.8 shall have overfill protection in accordance with API 2350.

An *approved* means or method in accordance with Section 444.4.1.7.5.5 shall be provided to prevent the overfilling of Class IIIB liquid storage tanks connected to fuel-burning equipment inside buildings.

444.4.1.5.6 Repair, alteration or reconstruction of tanks and piping. The repair, *alteration* or reconstruction, including welding, cutting and hot tapping of storage tanks and piping that have been placed in service, shall be in accordance with NFPA 30.

444.4.1.5.7 Design of supports. The design of the supporting structure for tanks shall be in accordance with this code and NFPA 30.

444.4.1.5.8 Locations subject to flooding. Where a tank is located in an area where it is subject to buoyancy because of a rise in the water table, flooding or accumulation of water from fire suppression operations, uplift protection shall be provided in accordance with Sections 22.14 and 23.14 of NFPA 30.

444.4.1.5.9 Corrosion protection. Where subject to external corrosion, tanks shall be fabricated from corrosion-resistant materials, coated or provided with corrosion protection in accordance with Section 23.3.5 of NFPA 30.

444.4.1.5.10 Tank lining. Steel tanks are allowed to be lined only for the purpose of protecting the interior from corrosion or providing compatibility with a material to be stored. Only those liquids tested for compatibility with the lining material are allowed to be stored in lined tanks.

444.4.1.6 Vaults. Vaults shall be allowed to be either above or below grade and shall comply with Sections 444.4.1.6.1 through 444.4.1.6.18.

444.4.1.6.1 Listing required. Vaults shall be listed in accordance with UL 2245.

Exception: Where *approved* by the *building official*, below-grade vaults are allowed to be constructed on-site, provided that the design is in accordance with this code and that special inspections are conducted to verify structural strength and compliance of the installation with the *approved* design in accordance with Section 1707. Installation plans for below-grade vaults that are constructed on-site shall be prepared by, and the design shall bear the stamp of, a professional engineer. Consideration shall be given to soil and hydrostatic loading on the floors, walls and lid; anticipated seismic forces; uplifting by groundwater or flooding; and loads imposed from above such as traffic and equipment loading on the vault lid.

444.4.1.6.2 Design and construction. The vault shall completely enclose each tank. There shall not be openings in the vault enclosure except those necessary for access to; inspection of; and filling, emptying and venting of the tank. The walls and floor of the vault shall be constructed of reinforced concrete not less than 6 inches (152 mm) thick. The top of an above-grade vault shall be constructed of noncombustible material and shall be designed to be weaker than the walls of the vault to ensure that the thrust of an explosion occurring inside the vault is directed upward before significantly high pressure can develop within the vault.

The top of an at-grade or below-grade vault shall be designed to relieve safely or contain the force of an explosion occurring inside the vault. The top and floor of the vault and the tank foundation shall be designed to withstand the anticipated loading, including loading from vehicular traffic, where applicable. The walls and floor of a vault installed below grade shall be designed to withstand anticipated soil and hydrostatic loading.

Vaults shall be designed to be wind and earthquake resistant, in accordance with this code.

444.4.1.6.3 Secondary containment. Vaults shall be substantially liquid tight and there shall not be backfill around the tank or within the vault. The vault floor shall drain to a sump. For premanufactured vaults, liquid tightness shall be certified as part of the listing provided by a nationally recognized testing laboratory. For field-erected vaults, liquid tightness shall be certified in an *approved* manner.

444.4.1.6.4 Internal clearance. There shall be sufficient clearance between the tank and the vault to allow for visual inspection and maintenance of the tank and its appurtenances. Dispensing devices are allowed to be installed on tops of vaults.

444.4.1.6.5 Anchoring. Vaults and their tanks shall be suitably anchored to withstand uplifting by ground water or flooding, including when the tank is empty.

444.4.1.6.6 Vehicle impact protection. Vaults shall be resistant to damage from the impact of a motor vehicle, or vehicle impact protection shall be provided in accordance with Section 912.4.4.

444.4.1.6.7 Arrangement. Tanks shall be *listed* for above-ground use, and each tank shall be in its own vault. Compartmentalized tanks shall be allowed and shall be considered as a single tank. Adjacent vaults shall be allowed to share a common wall. The common wall shall be liquid and vapor tight and shall be designed to withstand the load imposed when the vault on either side of the wall is filled with water.

444.4.1.6.8 Connections. Connections shall be provided to permit venting of each vault to dilute, disperse and remove vapors prior to personnel entering the vault.

444.4.1.6.9 Ventilation. Vaults that contain tanks of Class I liquids shall be provided with an exhaust ventilation system installed in accordance with Section 415.12.3. The ventilation system shall operate continuously or be designed to operate upon activation of the vapor or liquid detection system. The system shall provide ventilation at a rate of not less than 1 cubic foot per minute (cfm) per square foot of floor area [$0.00508 \text{ m}^3/(\text{s} \cdot \text{m}^2)$], but not less than 150 cfm ($4 \text{ m}^3/\text{min}$). The exhaust system shall be designed to provide air movement across all parts of the vault floor. Supply and exhaust ducts shall extend to within 3 inches (76 mm), but not more than 12 inches (305 mm), of the floor. The exhaust system shall be installed in accordance with the *Mechanical Code*.

444.4.1.6.10 Liquid detection. Vaults shall be equipped with a detection system capable of detecting liquids, including water, and activating an alarm.

444.4.1.6.11 Monitoring and detection. Vaults shall be provided with *approved* vapor and liquid detection systems and equipped with on-site audible and visual warning devices with battery backup. Vapor detection systems shall sound an alarm when the system detects vapors that reach or exceed 25 percent of the lower explosive limit (LEL) of the liquid stored. Vapor detectors shall be located not higher than 12 inches (305 mm) above the lowest point in the vault. Liquid detection systems shall sound an alarm upon detection of any liquid, including water. Liquid detectors shall be located in accordance with the manufacturer's instructions. Activation of either

vapor or liquid detection systems shall cause a signal to be sounded at an *approved*, constantly attended location within the facility serving the tanks or at an *approved* location. Activation of vapor detection systems shall shut off dispenser pumps.

444.4.1.6.12 Liquid removal. Means shall be provided to recover liquid from the vault. Where a pump is used to meet this requirement, the pump shall not be permanently installed in the vault.

444.4.1.6.13 Normal vents. Vent pipes that are provided for normal tank venting shall terminate not less than 12 feet (3658 mm) above ground level.

444.4.1.6.14 Emergency vents. Emergency vents shall be vapor tight and shall be allowed to discharge inside the vault. Long-bolt manhole covers shall not be allowed for this purpose.

444.4.1.6.15 Accessway. Vaults shall be provided with an *approved* personnel accessway with a minimum dimension of 30 inches (762 mm) and with a permanently affixed, nonferrous ladder. Accessways shall be designed to be nonsparking. Travel distance from any point inside a vault to an accessway shall not exceed 20 feet (6096 mm). At each entry point, a warning sign indicating the need for procedures for safe entry into confined spaces shall be posted. Entry points shall be secured against unauthorized entry and vandalism.

444.4.1.6.16 Fire protection. Vaults shall be provided with a suitable means to admit a fire suppression agent.

444.4.1.6.17 Classified area. The interior of a vault containing a tank that stores a Class I liquid shall be designated a Class I, Division 1, or Zone 0 location, as defined in the *Electrical Code*.

444.4.1.6.18 Overfill protection. Overfill protection shall be provided in accordance with Section 444.4.1.7.5.5. The use of a *float* vent valve shall be prohibited.

444.4.1.7 Above-ground tanks inside buildings. Above-ground storage of flammable and combustible liquids in tanks shall comply with Section 444.4.1 and Sections 444.4.1.7.1 through 444.4.1.7.5.9.

444.4.1.7.1 Fire protection. Fire protection for above-ground tanks within buildings shall comply with Sections 444.4.1.7.1.1 through 444.4.1.7.1.4.

444.4.1.7.1.1 Required foam fire protection systems. Where required by the *building official*, foam fire protection shall be provided for aboveground tanks within buildings, other than pressure tanks operating at or above 1

pound per square inch gauge (psig) (6.89 kPa) where such tank, or group of tanks spaced less than 50 feet (15 240 mm) apart measured shell to shell, has a liquid surface area in excess of 1,500 square feet (139 m²), and is in accordance with one of the following:

1. Used for the storage of Class I or II liquids.
2. Used for the storage of crude oil.
3. Used for in-process products and is located within 100 feet (30 480 mm) of a fired still, heater, related fractioning or processing apparatus or similar device at a processing plant or petroleum refinery as herein defined.
4. Considered by the *building official* as posing an unusual exposure hazard because of topographical conditions; nature of occupancy, proximity on the same or adjoining property, and height and character of liquids to be stored; degree of private fire protection to be provided; and facilities of the fire department to cope with flammable liquid fires.

444.4.1.7.1.2 Foam fire protection system installation. Where foam fire protection is required, it shall be installed in accordance with NFPA 11.

444.4.1.7.1.2.1 Foam storage. Where foam fire protection is required, foam-producing materials shall be stored on the premises.

Exception: Storage of foam-producing materials off the premises is allowed as follows:

1. Such materials stored off the premises shall be of the proper type suitable for use with the equipment at the installation where required.
2. Such materials shall be readily available at the storage location at all times.
3. Adequate loading and transportation facilities shall be provided.
4. The time required to deliver such materials to the required location in the event of fire shall be consistent with the hazards and fire scenarios for which the foam supply is intended.
5. At the time of a fire, these off-premises supplies shall be accumulated in sufficient quantities before placing the equipment in operation to ensure foam production at an adequate rate without interruption until extinguishment is accomplished.

444.4.1.7.1.3 Fire protection of supports. Supports or pilings for above-ground tanks storing Class I, II or IIIA liquids elevated more than 12 inches (305 mm) above grade shall have a *fire-resistance rating* of not less than 2 hours in accordance with the fire exposure criteria specified in ASTM E1529.

Exceptions:

1. Structural supports tested as part of a protected above-ground tank in accordance with UL 2085.
2. Stationary tanks located inside buildings equipped throughout with an *approved* automatic sprinkler system designed in accordance with Section 903.3.1.1.

444.4.1.7.1.4 Inerting of tanks storing boilover liquids. Liquids with boil-over characteristics shall not be stored in fixed roof tanks larger than 150 feet (45 720 mm) in diameter unless an *approved* gas enrichment or inerting system is provided on the tank.

444.4.1.7.2 Supports, foundations and anchorage. Supports, foundations and anchorages for aboveground tanks within buildings shall be designed and constructed in accordance with NFPA 30 and this code.

444.4.1.7.3 Stairways, platforms and walkways. Stairways, platforms and walkways shall be of noncombustible construction and shall be designed and constructed in accordance with NFPA 30 and this code.

444.4.1.7.4 Above-ground tanks inside buildings. Above-ground tanks inside buildings shall comply with Sections 444.4.1.7.4.1 and 444.4.1.7.4.2.

444.4.1.7.4.1 Overfill prevention. Aboveground tanks storing Class I, II and IIIA liquids inside buildings shall be equipped with a device or other means to prevent overflow into the building including, but not limited to: a *float valve*, a preset meter on the fill line, a valve actuated by the weight of the tank's contents, a low-head pump that is incapable of producing overflow, or a liquid-tight overflow pipe not less than one pipe size larger than the fill pipe and discharging by gravity back to the outside source of liquid or to an *approved* location. Tanks containing Class IIIB liquids and connected to fuel-burning equipment shall be provided with a means to prevent overflow into buildings in accordance with Section 444.4.1.5.5.7.

444.4.1.7.4.2 Fill pipe connections. Fill pipe connections for tanks storing Class I, II and IIIA liquids and Class IIIB liquids connected to fuel-burning equipment shall be in accordance with Section 444.4.1.7.5.6.

444.4.1.7.5 Additional requirements for protected above-ground tanks. In addition to the requirements of this section for above-ground tanks, the installation of protected above-ground tanks shall be in accordance with Sections 444.4.1.7.5.1 through 444.4.1.7.5.9.

444.4.1.7.5.1 Tank construction. The construction of a protected above-ground tank and its primary tank shall be in accordance with Section 444.4.1.5.

444.4.1.7.5.2 Normal and emergency venting. Normal and emergency venting for protected above-ground tanks shall be provided in accordance with Sections 444.4.1.5.3 and 444.4.1.5.4. The vent capacity reduction factor shall not be allowed.

444.4.1.7.5.3 Secondary containment. Protected above-ground tanks shall be provided with *secondary containment*, drainage control or diking in accordance with Section 415.12.1. A means shall be provided to establish the integrity of the *secondary containment* in accordance with NFPA 30.

444.4.1.7.5.4 Vehicle impact protection. Where protected above-ground tanks, piping, electrical conduit or dispensers are subject to vehicular impact, they shall be protected therefrom, either by having the impact protection incorporated into the system design in compliance with the impact test protocol of UL 2085 or by meeting the provisions of Section 912.4.4 or where necessary, a combination of both. Where guard posts or other *approved* barriers are provided, they shall be independent of each above-ground tank.

444.4.1.7.5.5 Overfill prevention. Protected above-ground tanks shall not be filled in excess of 95 percent of their capacity. An overfill prevention system shall be provided for each tank. During tank-filling operations, the system shall comply with one of the following:

1. The overfill prevention system shall include the following:
 - 1.1. An independent means of notifying the person filling the tank that the fluid level has reached 90 percent of tank capacity by providing an audible or visual alarm signal, providing a tank level gauge marked at 90 percent of tank capacity, or other *approved* means.

- 1.2. Automatic shut off of the flow of fuel to the tank when the quantity of liquid in the tank reaches 95 percent of tank capacity. For rigid hose fuel-delivery systems, an *approved* means shall be provided to empty the fill hose into the tank after the automatic shutoff device is activated.

2. The system shall reduce the flow rate to not more than 15 gallons per minute (0.95 L/s) so that at the reduced flow rate, the tank will not overflow for 30 minutes, and automatically shut off flow into the tank so that none of the fittings on the top of the tank are exposed to product because of overflowing.

444.4.1.7.5.5.1 Information signs. A permanent sign shall be provided at the fill point for the tank, documenting the filling procedure and the tank calibration chart.

444.4.1.7.5.6 Fill pipe connections. The fill pipe shall be provided with a means for making a direct connection to the tank vehicle's fuel delivery hose so that the delivery of fuel is not exposed to the open air during the filling operation. Where any portion of the fill pipe exterior to the tank extends below the level of the top of the tank, a check valve shall be installed in the fill pipe not more than 12 inches (305 mm) from the fill hose connection.

444.4.1.7.5.7 Spill containers. A spill container having a capacity of not less than 5 gallons (19 L) shall be provided for each fill connection. For tanks with a top fill connection, spill containers shall be noncombustible and shall be fixed to the tank and equipped with a manual drain valve that drains into the primary tank. For tanks with a remote fill connection, a portable spill container shall be allowed.

444.4.1.7.5.8 Tank openings. Tank openings in protected above-ground tanks shall be through the top only.

444.4.1.7.5.9 Antisiphon devices. *Approved* antisiphon devices shall be installed in each external pipe connected to the protected aboveground tank where the pipe extends below the level of the top of the tank.

444.4.1.8 Drainage and diking. The area surrounding a tank or group of tanks shall be provided with drainage control or shall be diked to prevent accidental discharge of liquid from endangering adjacent tanks, adjoining property, or reaching waterways.

Exceptions:

1. The *building official* is authorized to alter or waive these requirements based on a technical report that demonstrates that such tank or group of tanks does not constitute a hazard to other tanks, waterways or adjoining property after consideration of special features such as topographical conditions, nature of occupancy and proximity to buildings on the same or adjacent property, capacity, construction of proposed tanks and character of liquids to be stored, and nature and quantity of private and public fire protection provided.
2. Drainage control and diking is not required for *listed secondary containment* tanks.

444.4.1.8.1 Volumetric capacity. The volumetric capacity of the diked area shall be not less than the greatest amount of liquid that can be released from the largest tank within the diked area. The capacity of the diked area enclosing more than one tank shall be calculated by deducting the volume of the tanks other than the largest tank below the height of the dike.

444.4.1.8.2 Diked areas containing two or more tanks. Diked areas containing two or more tanks shall be subdivided in accordance with NFPA 30.

444.4.1.8.3 Protection of piping from exposure fires. Piping shall not pass through adjacent diked areas or impounding basins unless provided with a sealed sleeve or otherwise protected from exposure to fire.

444.4.1.8.4 Equipment, controls and piping in diked areas. Pumps, manifolds and fire protection equipment or controls shall not be located within diked areas or drainage basins or in a location where such equipment and controls would be endangered by fire in the diked area or drainage basin. Piping above ground shall be minimized and located as close as practical to the shell of the tank in diked areas or drainage basins.

Exceptions:

1. Pumps, manifolds and piping integral to the tanks or equipment being served, which is protected by intermediate diking, berms, drainage or fire protection such as water spray, monitors or resistive coating.
2. Fire protection equipment or controls that are appurtenances to the tanks or equipment being protected, such as foam chambers or foam piping, water or foam monitors and hydrants, or hand and wheeled extinguishers.

444.4.2 Liquid storage cabinets. Where other sections of this code require that liquid *containers* be stored in storage cabinets, such cabinets and storage shall be in accordance with Sections 444.4.2.1 and 444.4.2.2.

444.4.2.1 Design and construction of storage cabinets. Design and construction of liquid storage cabinets shall be in accordance with Sections 444.4.2.1.1 through 444.4.2.1.4.

444.4.2.1.1 Materials. Cabinets shall be *listed* in accordance with UL 1275 or constructed of *approved* wood or metal in accordance with the following:

1. Unlisted metal cabinets shall be constructed of steel having a thickness of not less than 0.044 inch (1.12 mm) (18 gage). The cabinet, including the door, shall be double walled with 1¹/₂-inch (38 mm) airspace between the walls. Joints shall be riveted or welded and shall be tight fitting.
2. Unlisted wooden cabinets, including doors, shall be constructed of not less than 1-inch (25 mm) exterior grade plywood. Joints shall be rabbeted and shall be fastened in two directions with wood screws. Door hinges shall be of steel or brass. Cabinets shall be painted with an intumescent-type paint.

444.4.2.1.2 Labeling. Cabinets shall be provided with a conspicuous label in red letters on contrasting background that reads: FLAMMABLE—KEEP FIRE AWAY.

444.4.2.1.3 Doors. Doors shall be well fitted, self-closing and equipped with a three-point latch.

444.4.2.1.4 Bottom. The bottom of the cabinet shall be liquid tight to a height of not less than 2 inches (51 mm).

444.4.2.2 Capacity. The combined total quantity of liquids in a cabinet shall not exceed 120 gallons (454 L).

444.4.3 Indoor storage. Storage of flammable and *combustible liquids* inside buildings in *containers* and *portable tanks* shall be in accordance with Sections 444.4.3.1 through 444.4.3.4.

Exceptions:

1. Liquids in the fuel tanks of motor vehicles, aircraft, boats or portable or stationary engines.
2. The storage of distilled spirits and wines in wooden barrels or casks.

444.4.3.1 Shelf storage. Shelving shall be of *approved* construction, adequately braced and anchored. Seismic requirements shall be in accordance with this code.

444.4.3.1.1 Use of wood. Wood of not less than 1 inch (25 mm) nominal thickness is allowed to be used as shelving, racks, dunnage, scuffboards, floor overlay and similar installations.

444.4.3.1.2 Displacement protection. Shelves shall be of sufficient depth and provided with a lip or guard to prevent individual *containers* from being displaced.

Exception: Shelves in storage cabinets or on laboratory furniture specifically designed for such use.

444.4.3.2 Rack storage. Where storage on racks is allowed elsewhere in this code, a minimum 4-foot-wide (1219 mm) aisle shall be provided between adjacent rack sections and any adjacent storage of liquids. Main aisles shall be not less than 8 feet (2438 mm) wide.

444.4.3.3 Pile or palletized storage. Solid pile and palletized storage in liquid warehouses shall be arranged so that piles are separated from each other by not less than 4 feet (1219 mm). Aisles shall be provided and arranged so that *containers* or *portable tanks* are not more than 20 feet (6096 mm) from an aisle. Main *aisles* shall be not less than 8 feet (2438 mm) wide.

444.4.3.4 Limited combustible storage. Limited quantities of combustible commodities are allowed to be stored in liquid storage areas where the ordinary combustibles, other than those used for packaging the liquids, are separated from the liquids in storage by not less than 8 feet (2438 mm) horizontally, either by open aisles or by open racks, and where protection is provided in accordance with Chapter 9.

444.4.4 Quantity limits for storage. Liquid storage quantity limitations shall comply with Sections 444.4.4.1 and 444.4.4.2.

444.4.4.1 Maximum allowable quantity per control area. For occupancies other than Group M wholesale and retail sales uses, indoor storage of flammable and *combustible liquids* shall not exceed the *maximum allowable quantities per control area* indicated in Table 307.1(1) and shall not exceed the additional limitations set forth in this section.

For Group M occupancy wholesale and retail sales uses, indoor storage of flammable and *combustible liquids* shall not exceed the *maximum allowable quantities per control area* indicated in Table 414.2.5(2).

Storage of hazardous production material flammable and *combustible liquids* in Group H-5 occupancies shall be in accordance with Section 415.11.

444.4.4.2 Quantities exceeding limits for control areas. Quantities exceeding those allowed in *control areas* set forth in Section 444.4.4.1 shall be in liquid storage rooms or *liquid storage warehouses* in accordance with Sections 444.4.7 and 444.4.8.

444.4.5 Storage in control areas. Storage of flammable and *combustible liquids* in *control areas* shall be in accordance with Section 444.4.5.1.

444.4.5.1 Basement storage. Class I liquids shall be allowed to be stored in *basements* in amounts not exceeding the *maximum allowable quantity per control area* for use-open systems in Table 307.1(1), provided that automatic suppression and other fire protection are provided in accordance with Chapter 9. Class II and IIIA liquids shall be allowed to be stored in *basements*, provided that automatic suppression and other fire protection are provided in accordance with Chapter 9.

444.4.6 Wholesale and retail sales uses. Flammable and *combustible liquids* in Group M occupancy wholesale and retail sales uses shall be in accordance with Sections 444.4.6.1 through 444.4.6.3, or Sections 10.10.2, 12.3.8, 16.4.1 through 16.4.3, 16.5.1 through 16.5.2.12, Tables 16.5.2.1 through 16.5.2.12, and Figures 16.4.1(a) through 16.14.1(c) of NFPA 30.

444.4.6.1 Container type. *Containers* for Class I liquids shall be metal.

Exception: In sprinklered buildings, an aggregate quantity of 120 gallons (454 L) of water-miscible Class IB and Class IC liquids is allowed in nonmetallic *containers*, each having a capacity of 16 ounces (0.473 L) or less.

444.4.6.2 Container capacity. *Containers* for Class I liquids shall not exceed a capacity of 5 gallons (19 L).

Exception: Metal *containers* not exceeding 55 gallons (208 L) are allowed to store up to 240 gallons (908 L) of the *maximum allowable quantity per control area* of Class IB and IC liquids in a *control area*. The building shall be equipped throughout with an *approved* automatic sprinkler system in accordance with Table 414.2.5(2). The *containers* shall be provided with plastic caps without cap seals and shall be stored upright. *Containers* shall not be stacked or stored in racks and shall not be located in areas open to the public.

444.4.6.3 Fire protection and storage arrangements. Fire protection and *container* storage arrangements shall be in accordance with Table 444.4.6.3(1) or the following:

1. Storage on shelves shall not exceed 6 feet (1829 mm) in height, and shelving shall be metal.

2. Storage on pallets or in piles greater than 4 feet 6 inches (1372 mm) in height, or where the ceiling exceeds 18 feet (5486 mm) in height, shall be protected in accordance with Table 444.4.6.3(4), and the storage heights and arrangements shall be limited to those specified in Table 444.4.6.3(2).
3. Storage on racks greater than 4 feet 6 inches (1372 mm) in height, or where the ceiling exceeds 18 feet (5486 mm) in height, shall be protected in accordance with Tables 444.4.6.3(5), 444.4.6.3(6) and 444.4.6.3(7) as appropriate, and the storage heights and arrangements shall be limited to those specified in Table 444.4.6.3(3).

Combustible commodities shall not be stored above flammable and *combustible liquids*.

444.4.7 Liquid storage rooms. Liquid storage rooms shall comply with Sections 444.4.7.1 through 444.4.7.5.1.

444.4.7.1 General. Quantities of liquids exceeding those set forth in Section 444.4.4.1 for storage in *control areas* shall be stored in a liquid storage room complying with this section and constructed and separated as required by this code.

444.4.7.2 Quantities and arrangement of storage. The quantity limits and storage arrangements in liquid storage rooms shall be in accordance with Tables 444.4.6.3(2) and 444.4.6.3(3) and Sections 444.4.7.2.1 and 444.4.7.2.2.

444.4.7.2.1 Mixed storage. Where two or more classes of liquids are stored in a pile or rack section, both of the following shall apply:

1. The quantity in that pile or rack shall not exceed the smallest of the maximum quantities for the classes of liquids stored in accordance with Table 444.4.6.3(2) or 444.4.6.3(3).
2. The height of storage in that pile or rack shall not exceed the smallest of the maximum heights for the classes of liquids stored in accordance with Table 444.4.6.3(2) or 444.4.6.3(3).

444.4.7.2.2 Separation and aisles. Piles shall be separated from each other by not less than 4-foot (1219 mm) aisles. Aisles shall be provided so that all *containers* are 20 feet (6096 mm) or less from an aisle. Where the storage of liquids is on racks, a minimum 4-foot-wide (1219 mm) aisle shall be provided between adjacent rows of racks and adjacent storage of liquids. Main aisles shall be not less than 8 feet (2438 mm) wide.

Additional aisles shall be provided for access to doors, required windows and ventilation openings, standpipe connections, mechanical equipment and switches. Such aisles shall be not less than 3 feet (914 mm) in width, unless greater

widths are required for separation of piles or racks, in which case the greater width shall be provided.

444.4.7.3 Spill control and secondary containment. Liquid storage rooms shall be provided with spill control and *secondary containment* in accordance with Section 415.12.1.

444.4.7.4 Ventilation. Liquid storage rooms shall be ventilated in accordance with Section 415.12.3.

444.4.7.5 Fire protection. Fire protection for liquid storage rooms shall comply with Section 444.4.7.5.1.

444.4.7.5.1 Fire protection systems. Liquid storage rooms shall be protected by *automatic sprinkler systems* installed in accordance with Chapter 9 and Tables 444.4.6.3(4) through 444.4.6.3(7) and Table 444.4.7.5.1. In-rack sprinklers shall also comply with NFPA 13.

Automatic foam-water systems and automatic aqueous film-forming foam (AFFF) water sprinkler systems shall not be used except where *approved*.

Protection criteria developed from fire modeling or full-scale fire testing conducted at an *approved* testing laboratory are allowed in lieu of the protection as shown in Tables 444.4.6.3(2) through 444.4.6.3(7) and Table 444.4.7.5.1 where *approved*.

444.4.8 Liquid storage warehouses. Buildings used for storage of flammable or *combustible liquids* in quantities exceeding those set forth in Section 444.4.4 for *control areas* and Section 444.4.7 for liquid storage rooms shall comply with Sections 444.4.8.1 through 444.4.8.5 and shall be constructed and separated as required by this code.

444.4.8.1 Quantities and storage arrangement. The total quantities of liquids in a *liquid storage warehouse* shall not be limited. The arrangement of storage shall be in accordance with Table 444.4.6.3(2) or 444.4.6.3(3).

444.4.8.1.1 Mixed storage. Mixed storage shall be in accordance with Section 444.4.7.2.1.

444.4.8.1.2 Separation and aisles. Separation and *aisles* shall be in accordance with Section 444.4.7.2.2.

444.4.8.2 Spill control and secondary containment. *Liquid storage warehouses* shall be provided with spill control and *secondary containment* as set forth in Section 415.12.1.

444.4.8.3 Ventilation. *Liquid storage warehouses* storing *containers* greater than 5 gallons (19 L) in capacity shall be ventilated at a rate of not less than 0.25 cfm per square foot (0.075 m³/s • m²) of floor area over the storage area.

444.4.8.4 Automatic sprinkler systems. *Liquid storage warehouses shall be protected by automatic sprinkler systems installed in accordance with Chapter 9 and Tables 444.4.6.3(4) through 444.4.6.3(7) and Table 444.4.7.5.1, or Sections 16.4.1 through 16.4.3, 16.5.1 through 16.5.2.12, Tables 16.5.2.1 through 16.5.2.12 and Figures 16.4.1(a) through 16.4.1(c) of NFPA 30. In-rack sprinklers shall also comply with NFPA 13.*

Automatic foam-water systems and automatic AFFF water sprinkler systems shall not be used except where approved.

Protection criteria developed from fire modeling or full-scale fire testing conducted at an approved testing laboratory are allowed in lieu of the protection as shown in Tables 444.4.6.3(2) through 444.4.6.3(7) and Table 444.4.7.5.1 where approved.

**TABLE 444.4.6.3(1)
MAXIMUM STORAGE HEIGHT IN CONTROL AREA**

TYPE OF LIQUID	NONSPRINKLERED AREA (feet)	SPRINKLERED AREA^a (feet)	SPRINKLERED WITH IN-RACK PROTECTION^{a, b} (feet)
Flammable liquids:			
Class IA	4	4	4
Class IB	4	8	12
Class IC	4	8	12
Combustible liquids:			
Class II	6	8	12
Class IIIA	8	12	16
Class IIIB	8	12	20

For SI: 1 foot = 304.8 mm.

- a. In buildings protected by an automatic sprinkler system, the storage height for containers and portable tanks shall not exceed the maximum storage height permitted for the fire protection scheme set forth in NFPA 30 or the maximum storage height demonstrated in a full-scale fire test, whichever is greater. NFPA 30 criteria and fire test results for metallic containers and portable tanks shall not be applied to nonmetallic containers and portable tanks.
- b. In-rack protection shall be in accordance with Table 444.4.6.3(5), 444.4.6.3(6) or 444.4.6.3(7).

TABLE 444.4.6.3(2)
STORAGE ARRANGEMENTS FOR PALLETIZED OR SOLID-PILE STORAGE IN LIQUID STORAGE ROOMS AND WAREHOUSES

CLASS	STORAGE LEVEL	MAXIMUM STORAGE HEIGHT			MAXIMUM QUANTITY PER PILE (gallons)		MAXIMUM QUANTITY PER ROOM ^a (gallons)	
		Drums	Containers ^b (feet)	Portable tanks ^b (feet)	Containers	Portable tanks	Containers	Portable tanks
IA	Ground floor	1	5	Not Allowed	3,000	Not Allowed	12,000	Not Allowed
	Upper floors	1	5	Not Allowed	2,000	Not Allowed	8,000	Not Allowed
	Basements	0	Not Allowed	Not Allowed	Not Allowed	Not Allowed	Not Allowed	Not Allowed
IB	Ground floor	1	6.5	7	5,000	20,000	15,000	40,000
	Upper floors	1	6.5	7	3,000	10,000	12,000	20,000
	Basements	0	Not Allowed	Not Allowed	Not Allowed	Not Allowed	Not Allowed	Not Allowed
IC	Ground floor ^d	1	6.5 ^c	7	5,000	20,000	15,000	40,000
	Upper floors	1	6.5 ^c	7	3,000	10,000	12,000	20,000
	Basements	0	Not Allowed	Not Allowed	Not Allowed	Not Allowed	Not Allowed	Not Allowed
II	Ground floor ^d	3	10	14	10,000	40,000	25,000	80,000
	Upper floors	3	10	14	10,000	40,000	25,000	80,000
	Basements	1	5	7	7,500	20,000	7,500	20,000
III	Ground floor	5	20	14	15,000	60,000	50,000	100,000
	Upper floors	5	20	14	15,000	60,000	50,000	100,000
	Basements	3	10	7	10,000	20,000	25,000	40,000

For SI: 1 foot = 304.8 mm, 1 gallon = 3.785 L.

- a. See Section 444.4.8.1 for unlimited quantities in liquid storage warehouses.
- b. In buildings protected by an automatic sprinkler system, the storage height for containers and portable tanks shall not exceed the maximum storage height permitted for the fire protection scheme set forth in NFPA 30 or the maximum storage height demonstrated in a full-scale fire test, whichever is greater. NFPA 30 criteria and fire test results for metallic containers and portable tanks shall not be applied to nonmetallic containers and portable tanks.
- c. These height limitations are allowed to be increased to 10 feet for containers having a capacity of 5 gallons or less.
- d. For palletized storage of unsaturated polyester resins (UPR) in relieving-style metal containers with 50 percent or less by weight Class IC or II liquid and no Class IA or IB liquid, height and pile quantity limits shall be permitted to be 10 feet and 15,000 gallons, respectively, provided that such storage is protected by sprinklers in accordance with NFPA 30 and that the UPR storage area is not located in the same containment area or drainage path for other Class I or II liquids.

TABLE 444.4.6.3(3)
STORAGE ARRANGEMENTS FOR RACK STORAGE IN LIQUID STORAGE ROOMS AND WAREHOUSES

CLASS	TYPE RACK	STORAGE LEVEL	MAXIMUM STORAGE HEIGHT ^b (feet)	MAXIMUM QUANTITY PER ROOM ^a (gallons)
			Containers	Containers
IA	Double row or Single row	Ground floor	25	7,500
		Upper floors	15	4,500
		Basements	Not Allowed	Not Allowed
IB IC	Double row or Single row	Ground floor	25	15,000
		Upper floors	15	9,000
		Basements	Not Allowed	Not Allowed
II	Double row or Single row	Ground floor	25	24,000
		Upper floors	25	24,000
		Basements	15	9,000
III	Multirow Double row Single row	Ground floor	40	48,000
		Upper floors	20	48,000
		Basements	20	24,000

For SI: 1 foot = 304.8 mm, 1 gallon = 3.785 L.

- a. See Section 444.4.8.1 for unlimited quantities in liquid storage warehouses.
- b. In buildings protected by an automatic sprinkler system, the storage height for containers and portable tanks shall not exceed the maximum storage height permitted for the fire protection scheme set forth in NFPA 30 or the maximum storage height demonstrated in a full-scale fire test, whichever is greater. NFPA 30 criteria and fire test results for metallic containers and portable tanks shall not be applied to nonmetallic containers and portable tanks.

TABLE 444.4.6.3(4)
AUTOMATIC SPRINKLER PROTECTION FOR SOLID-PILE AND PALLETIZED STORAGE OF LIQUIDS IN METAL CONTAINERS AND PORTABLE TANKS^a

STORAGE CONDITIONS		CEILING SPRINKLER DESIGN AND DEMAND				MINIMUM HOSE STREAM DEMAND (gpm)	MINIMUM DURATION SPRINKLERS AND HOSE STREAMS (hours)
Class liquid	Container size and arrangement	Density (gpm/ ft ²)	Area (square feet)		Maximum spacing (square feet)		
			High temperature sprinklers	Ordinary temperature sprinklers			
IA	5 gallons or less, with or without cartons, palletized or solid pile ^b	0.30	3,000	5,000	100	750	2
	Containers greater than 5 gallons, on end or side, palletized or solid pile	0.60	5,000	8,000	80	750	---
IB, IC and II	5 gallons or less, with or without cartons, palletized or solid pile ^b	0.30	3,000	5,000	100	500	2
	Containers greater than 5 gallons on pallets or solid pile, one high	0.25	5,000	8,000	100		
II	Containers greater than 5 gallons on pallets or solid pile, more than one high, on end or side	0.60	5,000	8,000	80	750	2
IB, IC and II	Portable tanks, one high	0.30	3,000	5,000	100	500	2
II	Portable tanks, two high	0.60	5,000	8,000	80	750	2
III	5 gallons or less, with or without cartons, palletized or solid pile	0.25	3,000	5,000	120	500	1
	Containers greater than 5 gallons on pallets or solid pile, on end or sides, up to three high	0.25	3,000	5,000	120	500	1
	Containers greater than 5 gallons, on pallets or solid pile, on end or sides, up to 18 feet high	0.35	3,000	5,000	100	750	2
	Portable tanks, one high	0.25	3,000	5,000	120	500	1
	Portable tanks, two high	0.50	3,000	5,000	80	750	2

For SI: 1 foot = 304.8 mm, 1 gallon = 3.785 L, 1 square foot = 0.0929 m², 1 gallon per minute = 3.785 L/m, 1 gallon per minute per square foot = 40.75 L/min/m².

- a. The design area contemplates the use of Class II standpipe systems. Where Class I standpipe systems are used, the area of application shall be increased by 30 percent without revising density.
- b. For storage heights above 4 feet or ceiling heights greater than 18 feet, an approved engineering design shall be provided in accordance with Section 104.7.2.

TABLE 444.4.6.3(5)
AUTOMATIC SPRINKLER PROTECTION REQUIREMENTS FOR RACK STORAGE OF LIQUIDS IN METAL CONTAINERS OF 5-GALLON CAPACITY OR LESS WITH OR WITHOUT CARTONS ON CONVENTIONAL WOOD PALLETS^a

CLASS LIQUID	CEILING SPRINKLER DESIGN AND DEMAND			IN-RACK SPRINKLER ARRANGEMENT AND DEMAND				MINIMUM HOSE STREAM DEMAND (gpm)	MINIMUM DURATION SPRINKLER AND HOSE STREAM (hours)	
	Density (gpm/ft ²)	Area (square feet)		Maximum spacing	Racks up to 9 feet deep	Racks more than 9 feet to 12 feet deep	Number of sprinklers operating			
		High-temperature sprinklers	Ordinary temperature sprinklers							30 psi (standard orifice)
I (maximum 25-foot height) Option 1	0.40	3,000	5,000	80 ft ² /head	<ol style="list-style-type: none"> Ordinary temperature, quick-response sprinklers, maximum 8 feet 3 inches horizontal spacing One line of sprinklers above each level of storage Locate in longitudinal flue space, staggered vertical Shields required where multiple level 	<ol style="list-style-type: none"> Ordinary-temperature, quick-response sprinklers, maximum 8 feet 3 inches horizontal spacing One line of sprinklers above each level of storage Locate in transverse flue spaces, staggered vertical and within 20 inches of aisle Shields required where multiple level 	30 psi (0.5-inch orifice)	<ol style="list-style-type: none"> Eight sprinklers if only one level Six sprinklers each on two levels if only two levels Six sprinklers each on top three levels, if three or more levels Hydraulically most remote 	750	2
I (maximum 25-foot height) Option 2	0.55	2,000 ^b	Not Applicable	100 ft ² /head	<ol style="list-style-type: none"> Ordinary temperature, quick-response sprinklers, maximum 8 feet 3 inches horizontal spacing See 2 above See 3 above See 4 above 	<ol style="list-style-type: none"> Ordinary-temperature, quick-response sprinklers, maximum 8 feet 3 inches horizontal spacing See 2 above See 3 above See 4 above 	14 psi (0.53-inch orifice)	See 1 through 4 above	500	2
I and II (maximum 14-foot storage height) (maximum three tiers)	0.55 ^c	2,000 ^d	Not Applicable	100 ft ² /head	Not Applicable. None for maximum 6-foot-deep racks	Not Applicable	Not Applicable	Not Applicable	500	2
II (maximum 25-foot height)	0.30	3,000	5,000	100 ft ² /head	<ol style="list-style-type: none"> Ordinary-temperature sprinklers 8 feet apart horizontally One line of sprinklers between levels at nearest 10-foot vertical intervals Locate in longitudinal flue space, staggered vertical Shields required where multiple level 	<ol style="list-style-type: none"> Ordinary-temperature sprinklers 8 feet apart horizontally Two lines between levels at nearest 10-foot vertical intervals Locate in transverse flue spaces, staggered vertical and within 20 inches of aisle Shields required where multiple level 	30 psi	Hydraulically most remote—six sprinklers at each level, up to a maximum of three levels	750	2
III (40-foot height)	0.25	3,000	5,000	120 ft ² /head	Same as for Class II liquids	Same as for Class II liquids	30 psi	Same as for Class II liquids	500	2

For SI: 1 inch = 25.4 mm, 1 foot = 304.8 mm, 1 square foot = 0.0929 m², 1 pound per square inch = 6.895 kPa, 1 gallon = 3.785 L, 1 gallon per minute = 3.785 L/m, 1 gallon per minute per square foot = 40.75 L/min/m².

- The design area contemplates the use of Class II standpipe systems. Where Class I standpipe systems are used, the area of application shall be increased by 30 percent without revising density.
- Using listed or approved extra-large orifices, high-temperature, quick-response or standard element sprinklers under a maximum 30-foot ceiling with minimum 7.5-foot aisles.
- For friction lid cans and other metal containers equipped with plastic nozzles or caps, the density shall be increased to 0.65 gpm per square foot using listed or approved extra-large orifice, high-temperature quick-response sprinklers.
- Using listed or approved extra-large orifice, high-temperature quick-response or standard element sprinklers under a maximum 18-foot ceiling with minimum 7.5-foot aisles and metal containers.

**TABLE 444.4.6.3(6)
AUTOMATIC SPRINKLER PROTECTION REQUIREMENTS FOR RACK STORAGE OF LIQUIDS IN METAL CONTAINERS
GREATER THAN 5-GALLON CAPACITY^a**

CLASS LIQUID	CEILING SPRINKLER DESIGN AND DEMAND			IN-RACK SPRINKLER ARRANGEMENT AND DEMAND					MINIMUM HOSE STREAM DEMAND (gpm)	MINIMUM DURATION SPRINKLER AND HOSE STREAM (hours)
	Density (gpm/ft ²)	Area (square feet)		Maximum spacing	On-side storage racks up to 9-foot-deep racks	On-end storage (on pallets) up to 9-foot-deep racks	Minimum nozzle pressure	Number of sprinklers operating		
High-temperature sprinklers		Ordinary temperature sprinklers								
I (maximum 25-foot height)	0.60	3,000	5,000	80 ft ² /head	<ol style="list-style-type: none"> Ordinary temperature sprinklers 8 feet apart horizontally One line of sprinklers above each tier of storage Locate in longitudinal flue space, staggered vertical Shields required where multiple level 	<ol style="list-style-type: none"> Ordinary temperature sprinklers 8 feet apart horizontally One line of sprinklers above each tier of storage Locate in longitudinal flue space, staggered vertical Shields required where multiple level 	30 psi	Hydraulically most remote six sprinklers at each level	1,000	2
II, IC and II (maximum 25-foot height)	0.60	3,000	5,000	100 ft ² /head	<ol style="list-style-type: none"> See 1 above One line of sprinklers every three tiers of storage See 3 above See 4 above 	<ol style="list-style-type: none"> See 1 above See 2 above See 3 above See 4 above 	30 psi	Hydraulically most remote six sprinklers at each level	750	2
III (maximum 40-foot height)	0.25	3,000	5,000	120 ft ² /head	<ol style="list-style-type: none"> See 1 above One line of sprinklers every sixth level (maximum) See 3 above See 4 above 	<ol style="list-style-type: none"> See 1 above One line of sprinklers every third level (maximum) See 3 above See 4 above 	15 psi	Hydraulically most remote six sprinklers at each level	500	1

For SI: 1 foot = 304.8 mm, 1 square foot = 0.0929 m², 1 pound per square inch = 6.895 kPa, 1 gallon = 3.785 L, 1 gallon per minute = 3.785 L/min, 1 gallon per minute per square foot = 40.75 L/min/m².

a. The design assumes the use of Class II standpipe systems. Where a Class I standpipe system is used, the area of application shall be increased by 30 percent without revising density.

TABLE 444.4.6.3(7)
AUTOMATIC AFFF WATER PROTECTION REQUIREMENTS FOR RACK STORAGE OF LIQUIDS IN METAL CONTAINERS
GREATER THAN 5-GALLON CAPACITY^{a, b}

CLASS LIQUID	CEILING SPRINKLER DESIGN AND DEMAND			IN-RACK SPRINKLER ARRANGEMENT AND DEMAND ^c			DURATION AFFF SUPPLY (minimum)	DURATION WATER SUPPLY (hours)	
	Density (gpm/ft ²)	Area (square feet)		On-end storage of drums on pallets, up to 25 feet	Minimum nozzle pressure (psi)	Number of sprinklers operating			Hose stream demand ^d (gpm)
	High-temperature sprinklers	Ordinary temperature sprinklers							
IA, IB, IC and II	0.30	1,500	2,500	1. Ordinary-temperature sprinklers up to 10 feet apart horizontally 2. One line of sprinklers above each level of storage 3. Locate in longitudinal flue space, staggered vertically 4. Shields required for multiple level	30	Three sprinklers per level	500	15	2

For SI: 1 inch = 25.4 mm, 1 foot = 304.8 mm, 1 square foot = 0.0929 m², 1 pound per square inch = 6.895 kPa, 1 gallon = 3.785 L, 1 gallon per minute = 3.785 L/m, 1 gallon per minute per square foot = 40.75 L/min/m².

a. System shall be a closed-head wet system with approved devices for proportioning aqueous film-forming foam.

b. Except as modified herein, in-rack sprinklers shall be installed in accordance with NFPA 13.

c. The height of storage shall not exceed 25 feet.

d. Hose stream demand includes 1 1/2-inch inside hose connections, where required.

TABLE 444.4.6.3(8)
AUTOMATIC SPRINKLER PROTECTION REQUIREMENTS FOR CLASS I LIQUID STORAGE IN METAL CONTAINERS OF 1-GALLON CAPACITY OR LESS WITH UNCARTONED OR CASE-CUT SHELF DISPLAY UP TO 6.5 FEET, AND PALLETIZED STORAGE ABOVE IN A DOUBLE-ROW RACK ARRAY^a

STORAGE HEIGHT	CEILING SPRINKLER DESIGN AND DEMAND				IN-RACK SPRINKLER ARRANGEMENT AND DEMAND			MINIMUM HOSE STREAM DEMAND (gpm)	MINIMUM DURATION SPRINKLERS AND HOSE STREAM (hours)	
	Density (gpm/ft ²)	Area (square feet)		Maximum spacing	Racks up to 9 feet deep	Racks 9 to 12 feet	Minimum nozzle pressure			Number of sprinklers operating
	High temperature	Ordinary temperature								
Maximum 20-foot storage height	0.60	2,000 ^b	Not Applicable	100 ft ² /head	1. Ordinary-temperature, quick-response sprinklers, maximum 8 feet 3 inches horizontal spacing 2. One line of sprinklers at the 6-foot level and the 11.5-foot level of storage 3. Locate in longitudinal flue space, staggered vertical 4. Shields required where multiple level	Not Applicable	30 psi (standard orifice) or 14 psi (large orifice)	1. Six sprinklers each on two levels 2. Hydraulically most remote 12 sprinklers	500	2

For SI: 1 inch = 25.4 mm, 1 foot = 304.8 mm, 1 square foot = 0.0929 m², 1 pound per square inch = 6.895 kPa, 1 gallon = 3.785 L, 1 gallon per minute = 3.785 L/m, 1 gallon per minute per square foot = 40.75 L/min/m².

a. This table shall not apply to racks with solid shelves.

b. Using extra-large orifice sprinklers under a ceiling 30 feet or less in height. Minimum aisle width is 7.5 feet.

**TABLE 444.4.7.5.1
AUTOMATIC AFFF-WATER PROTECTION REQUIREMENTS FOR SOLID-PILE AND PALLETIZED STORAGE OF LIQUIDS IN METAL CONTAINERS OF 5-GALLON CAPACITY OR LESS^{a, b}**

PACKAGE TYPE	CLASS LIQUID	CEILING SPRINKLER DESIGN AND DEMAND					STORAGE HEIGHT (feet)	HOSE DEMAND (gpm) ^c	DURATION AFFF SUPPLY (minimum)	DURATION WATER SUPPLY (hours)
		Density (gpm/ft ²)	Area (square feet)	Temperature rating	Maximum spacing	Orifice size (inch)				
Cartoned	IB, IC, II and III	0.40	2,000	286°F	100 ft ² /head	0.531	11	500	15	2
Uncartoned	IB, IC, II and III	0.30	2,000	286°F	100 ft ² /head	0.5 or 0.531	12	500	15	2

For SI: 1 inch = 25.4 mm, 1 foot = 304.8 mm, 1 square foot = 0.0929 m², 1 gallon per minute = 3.785 L/m, 1 gallon per minute per square foot = 40.75 L/min/m², °C = [(°F) - 32]/1.8.

- a. System shall be a closed-head wet system with approved devices for proportioning aqueous film-forming foam.
- b. Maximum ceiling height of 30 feet.
- c. Hose stream demand includes 1½-inch inside hose connections, where required.

444.4.8.5 Warehouse hose lines. In liquid storage warehouses, either 1½-inch (38 mm) lined or 1-inch (25 mm) hard rubber hose lines shall be provided in sufficient number to reach all liquid storage areas and shall be in accordance with Section 903 or 905.

444.4.9 Weather protection. Weather protection for outdoor storage shall be in accordance with Section 415.12.9.

444.5 Dispensing, use, mixing and handling. Dispensing, use, mixing and handling of flammable liquids shall be in accordance with Section 444.2 and this section. Tank vehicle and tank car loading and unloading and other special operations shall be in accordance with Section 444.6.

Exception: Containers of organic coatings having no fire point and which are opened for pigmentation are not required to comply with this section.

444.5.1 Liquid transfer. Liquid transfer equipment and methods for transfer of Class I, II and IIIA liquids shall be approved and be in accordance with Sections 444.5.1.1 through 444.5.1.5.

444.5.1.1 Pumps. Where positive-displacement pumps are used, they shall be provided with pressure relief discharging back to the tank, pump suction or other approved location, or shall be provided with interlocks to prevent overpressure.

444.5.1.2 Pressured systems. Where gases are introduced to provide for transfer of Class I liquids, or Class II and III liquids transferred at temperatures at or above their flash points by pressure, only inert gases shall be used. Controls, including pressure relief devices, shall be provided to limit the pressure so that the maximum working pressure of tanks and containers cannot be exceeded. Where devices operating through pressure within a tank or container are used, the tank or container shall be a pressure vessel approved for the intended use. Air or oxygen shall not be used for pressurization.

Exception: Air transfer of Class II and III liquids at temperatures below their flash points.

444.5.1.3 Class I, II and III liquids. Class I liquids, or when heated to or above their flash points, Class II and Class III liquids, shall be transferred by one of the following methods:

1. From safety cans complying with UL 30.
2. Through an approved closed piping system.
3. From containers or tanks by an approved pump taking suction through an opening in the top of the container or tank.
4. For Class IB, IC, II and III liquids, from containers or tanks by gravity through an approved selfclosing or automatic-closing valve where the container or tank and dispensing operations are provided with spill control and secondary containment in accordance with Section 415.12.1. Class IA liquids shall not be dispensed by gravity from tanks.
5. Approved engineered liquid transfer systems.

Exception: Liquids in original shipping containers not exceeding a 5.3-gallon (20 L) capacity.

444.5.1.4 Manual container filling operations. Class I liquids or Class II and Class III liquids that are heated up to or above their flash points shall not be transferred into containers unless the nozzle and containers are electrically interconnected. Acceptable methods of electrical interconnection include either of the following:

1. Metallic floor plates on which containers stand while filling, where such floor plates are electrically connected to the fill stem.
2. Where the fill stem is bonded to the container during filling by means of a bond wire.

444.5.1.5 Automatic container-filling operations for Class I liquids. Container-filling operations for Class I liquids involving conveyor belts or other automatic feeding operations shall be designed to prevent static accumulations.

444.5.2 Use, dispensing and mixing inside buildings. Indoor use, dispensing and mixing of flammable and *combustible liquids* shall be in accordance with Section 444.5.1 and Sections 444.5.2.1 through 444.5.2.5.5.

444.5.2.1 Closure of mixing or blending vessels. Vessels used for mixing or blending of Class I liquids and Class II or III liquids heated up to or above their *flash points* shall be provided with self-closing, tight-fitting, noncombustible lids that will control a fire within such vessel.

Exception: Where such devices are impractical, *approved* automatic or manually controlled fire-extinguishing devices shall be provided.

444.5.2.2 Bonding of vessels. Where differences of potential could be created, vessels containing Class I liquids or liquids handled at or above their *flash points* shall be electrically connected by bond wires, ground cables, piping or similar means to a static grounding system to maintain equipment at the same electrical potential to prevent sparking.

444.5.2.3 Heating, lighting and cooking appliances. Heating, lighting and cooking appliances that utilize Class I liquids shall not be operated within a building or structure.

Exception: Operation in single-family *dwelling*s.

444.5.2.4 Quantity limits for use. Liquid use quantity limitations shall comply with Sections 444.5.2.4.1 and 444.5.2.4.2.

444.5.2.4.1 Maximum allowable quantity per control area. Indoor use, dispensing and mixing of flammable and *combustible liquids* shall not exceed the *maximum allowable quantity per control area* indicated in Table 307.1(1) and shall not exceed the additional limitations set forth in Section 444.5.2.4.

Use of hazardous production material flammable and *combustible liquids* in Group H-5 occupancies shall be in accordance with Chapter 27.

Exception: Cleaning with Class I, II and IIIA liquids shall be in accordance with Section 444.5.2.5.

444.5.2.4.2 Quantities exceeding limits for control areas. Quantities exceeding the *maximum allowable quantity per control area* indicated in Section 444.5.2.4.1 shall be in accordance with the following:

1. For *open systems*, indoor use, dispensing and mixing of flammable and *combustible liquids* shall be within a room or building complying with this code and Sections 444.5.2.6.1 through 444.5.2.6.5.3.

2. For *closed systems*, indoor use, dispensing and mixing of flammable and *combustible liquids* shall be within a room or building complying with this code and Sections 444.5.2.6 through 444.5.2.6.4, and Section 444.5.2.6.6.

444.5.2.5 Cleaning with flammable and combustible liquids. Cleaning with Class I, II and IIIA liquids shall be in accordance with Sections 444.5.2.5.1 through 444.5.2.5.5.

444.5.2.5.1 Machine capacities. The quantity of solvent shall not exceed the *listed* design capacity of the machine for the solvent being used with the machine.

444.5.2.5.2 Solvent quantity limits. Solvent quantities shall be limited as follows:

1. Machines without remote solvent reservoirs shall be limited to quantities set forth in Section 444.5.2.4.
2. Machines with remote solvent reservoirs using Class I liquids shall be limited to quantities set forth in Section 444.5.2.4.
3. Machines with remote solvent reservoirs using Class II liquids shall be limited to 35 gallons (132 L) per machine. The total quantities shall not exceed an aggregate of 240 gallons (908 L) per *control area* in buildings not equipped throughout with an *approved* automatic sprinkler system and an aggregate of 480 gallons (1817 L) per *control area* in buildings equipped throughout with an *approved* automatic sprinkler system in accordance with Section 903.3.1.1.
4. Machines with remote solvent reservoirs using Class IIIA liquids shall be limited to 80 gallons (303 L) per machine.

444.5.2.5.3 Separation. Multiple machines shall be separated from each other by a distance of not less than 30 feet (9144 mm) or by a *fire barrier* with a minimum 1-hour *fire-resistance rating*.

444.5.2.5.4 Ventilation. Machines shall be located in areas adequately ventilated to prevent accumulation of vapors.

444.5.2.5.5 Installation. Machines shall be installed in accordance with their listings.

444.5.2.6 Rooms or buildings for quantities exceeding the maximum allowable quantity per control area. Where required by Section 444.5.2.4.2, rooms or buildings used for the use, dispensing or mixing of flammable and *combustible liquids* in quantities exceeding the *maximum allowable quantity per control area* shall be in accordance with Sections 444.5.2.6.1 through 444.5.2.6.6.3.

444.5.2.6.1 Construction, location and fire protection. Rooms or buildings classified in accordance with this code as Group H-2 or H-3 occupancies based on use, dispensing or mixing of flammable or *combustible liquids* shall be constructed in accordance with this code.

444.5.2.6.2 Basements. In rooms or buildings classified in accordance with this code as Group H-2 or H-3, dispensing or mixing of flammable or *combustible liquids* shall not be conducted in *basements*.

444.5.2.6.3 Fire protection. Rooms or buildings classified in accordance with this code as Group H-2 or H-3 occupancies shall be equipped with an *approved* automatic fire-extinguishing system in accordance with Chapter 9.

444.5.2.6.4 Doors. Interior doors to rooms or portions of such buildings shall be self-closing fire doors in accordance with this code.

444.5.2.6.5 Open systems. Use, dispensing and mixing of flammable and *combustible liquids* in *open systems* shall be in accordance with Sections 444.5.2.6.5.1 through 444.5.2.6.5.3.

444.5.2.6.5.1 Ventilation. Continuous mechanical ventilation shall be provided at a rate of not less than 1 cfm per square foot [$0.00508 \text{ m}^3/(\text{s} \cdot \text{m}^2)$] of floor area over the design area. Provisions shall be made for introduction of makeup air in such a manner to include all floor areas or pits where vapors can collect. Local or spot ventilation shall be provided where needed to prevent the accumulation of hazardous vapors. Ventilation system design shall comply with this code and the *Mechanical Code*.

Exception: Where natural ventilation can be shown to be effective for the materials used, dispensed or mixed.

444.5.2.6.5.2 Explosion control. Explosion control shall be provided in accordance with Section 919.

444.5.2.6.5.3 Spill control and secondary containment. Spill control shall be provided in accordance with Section 415.12.1 where Class I, II or IIIA liquids are dispensed into *containers* exceeding a 1.3-gallon (5 L) capacity or mixed or used in open *containers* or systems exceeding a 5.3-gallon (20 L) capacity. Spill control and *secondary containment* shall be provided in accordance with Section 415.12.1 where the capacity of an individual *container* exceeds 55 gallons (208 L) or the aggregate capacity of multiple *containers* or tanks exceeds 100 gallons (378.5 L).

444.5.2.6.6 Closed systems. Use or mixing of flammable or *combustible liquids* in *closed systems* shall be in accordance with Sections 444.5.2.6.6.1 through 444.5.2.6.6.3.

444.5.2.6.6.1 Ventilation. *Closed systems* designed to be opened as part of normal operations shall be provided with ventilation in accordance with Section 444.5.2.6.5.1.

444.5.2.6.6.2 Explosion control. Explosion control shall be provided where an explosive environment can occur as a result of the mixing or use process. Explosion control shall be designed in accordance with Section 919.

Exception: Where process vessels are designed to contain fully the worst-case explosion anticipated within the vessel under process conditions considering the most likely failure.

444.5.2.6.6.3 Spill control and secondary containment. Spill control shall be provided in accordance with Section 415.12.1 where flammable or *combustible liquids* are dispensed into *containers* exceeding a 1.3-gallon (5 L) capacity or mixed or used in open *containers* or systems exceeding a 5.3-gallon (20 L) capacity. Spill control and *secondary containment* shall be provided in accordance with Section 415.12.1 where the capacity of an individual *container* exceeds 55 gallons (208 L) or the aggregate capacity of multiple *containers* or tanks exceeds 1,000 gallons (3785 L).

444.5.2.7 Weather protection. Weather protection for outdoor use shall be in accordance with Section 415.12.9.

444.5.3 Solvent distillation units. *Solvent distillation units* shall comply with Sections 444.5.3.1 through 444.4.3.8.

444.5.3.1 Unit with a capacity of 60 gallons or less. *Solvent distillation units* used to recycle Class I, II or IIIA liquids having a distillation chamber capacity of 60 gallons (227 L) or less shall be *listed, labeled* and installed in accordance with Section 444.5.3 and UL 2208.

Exceptions:

1. *Solvent distillation units* used in continuous through-put industrial processes where the source of heat is remotely supplied using steam, hot water, oil or other heat transfer fluids, the temperature of which is below the auto-ignition point of the solvent.
2. *Approved* research, testing and experimental processes.

444.5.3.2 Units with a capacity exceeding 60 gallons. *Solvent distillation units* used to recycle Class I, II or IIIA liquids having a distillation chamber capacity exceeding 60 gallons (227 L) shall be used in locations that comply with the use and mixing requirements of Section 444.5 and other applicable provisions in this section.

444.5.3.3 Prohibited processing. Class I, II and IIIA liquids that are classified as unstable (reactive) shall not be processed in *solvent distillation units*.

Exception: Appliances listed for the distillation of unstable (reactive) solvents.

444.5.3.4 Labeling. A permanent label shall be affixed to the unit by the manufacturer. The label shall indicate the capacity of the distillation chamber and the distance the unit shall be placed away from sources of ignition. The label shall indicate the products for which the unit has been listed for use or refer to the instruction manual for a list of the products.

444.5.3.5 Manufacturer's instruction manual. An instruction manual shall be provided. The manual shall be readily available for the user and the *building official*. The manual shall include installation, use and servicing instructions. It shall identify the liquids for which the unit has been listed for distillation purposes along with each liquid's *flash point* and auto-ignition temperature. For units with adjustable controls, the manual shall include directions for setting the heater temperature for each liquid to be instilled.

444.5.3.6 Location. *Solvent distillation units* shall be used in locations in accordance with the listing. *Solvent distillation units* shall not be used in *basements*.

444.5.3.7 Storage of liquids. Distilled liquids and liquids awaiting distillation shall be stored in accordance with Section 444.4.

444.5.3.8 Storage of residues. Hazardous residue from the distillation process shall be stored in accordance with Section 444.4 and Sections 414 and 415.

444.6 Bulk plants or terminals. Portions of properties where flammable and *combustible liquids* are received by tank vessels, pipelines, tank cars or tank vehicles and stored or blended in bulk for the purpose of distribution by tank vessels, pipelines, tanks cars, tank vehicles or *containers* shall be in accordance with Sections 444.6.1 through 444.6.6.5.

444.6.1 Building construction. Buildings shall be constructed in accordance with this code.

444.6.2 Means of egress. Rooms in which liquids are stored, used or transferred by pumps shall have *means of egress* arranged to prevent occupants from being trapped in the event of fire.

444.6.3 Heating. Rooms in which Class I liquids are stored or used shall be heated only by means not

constituting a source of ignition, such as steam or hot water. Rooms containing heating appliances involving sources of ignition shall be located and arranged to prevent entry of flammable vapors.

444.6.4 Ventilation. Ventilation shall be provided for rooms, buildings and enclosures in which Class I liquids are pumped, used or transferred. Design of ventilation systems shall consider the relatively high specific gravity of the vapors. Where natural ventilation is used, adequate openings in outside walls at floor level, unobstructed except by louvers or coarse screens, shall be provided. Where natural ventilation is inadequate, mechanical ventilation shall be provided in accordance with the *Mechanical Code*.

444.6.4.1 Basements and pits. Class I liquids shall not be stored or used within a building having a *basement* or pit into which flammable vapors can travel, unless such area is provided with ventilation designed to prevent the accumulation of flammable vapors therein.

444.6.4.2 Dispensing of Class I liquids. *Containers* of Class I liquids shall not be drawn from or filled within buildings unless a provision is made to prevent the accumulation of flammable vapors in hazardous concentrations. Where mechanical ventilation is required, it shall be kept in operation while flammable vapors could be present.

444.6.5 Storage. Storage of Class I, II and IIIA liquids in bulk plants shall be in accordance with the applicable provisions of Section 444.4.

See Section 101.2.1 for the scope of regulation for piers and wharves regulation.

444.6.6 Wharves. This section shall apply to all regulated wharves, piers, bulkheads and other structures over or contiguous to navigable water having a primary function of transferring liquid cargo in bulk between shore installations and tank vessels, ships, barges, lighter boats or other mobile *floating craft*.

Exception: Marine motor fuel-dispensing facilities in accordance with Section 406.7.

444.6.6.1 Transferring location. Wharves at which liquid cargoes are to be transferred in bulk quantities to or from tank vessels shall be not less than 100 feet (30 480 mm) from any bridge over a navigable waterway or from an entrance to, or superstructure of, any vehicular or railroad tunnel, under a waterway. The termination of the fixed piping used for loading or unloading at a wharf shall be not less than 200 feet (60 960 mm) from a bridge or from an entrance to, or superstructures of, a tunnel.

444.6.6.2 Superstructure and decking material. Superstructure and decking shall be designed for the intended use. Decking shall be constructed of materials that will afford the desired combination of flexibility, resistance to shock, durability, strength and *fire resistance*.

444.6.6.3 Tanks allowed. Tanks used exclusively for ballast water or Class II or III liquids are allowed to be installed on suitably designed wharves.

444.6.6.4 Fire protection. Fire protection shall be in accordance with Chapter 9 and Section 444.6.6.5.

444.6.6.5 Fire hoses. Where piped water is available, ready-connected fire hose in a size appropriate for the water supply shall be provided in accordance with Section 905 so that manifolds where connections are made and broken can be reached by not less than one hose stream.

444.7 Bulk transfer and process transfer operations. Bulk transfer and *process transfer* operations shall be approved and be in accordance with Sections 444.7.1 through 444.7.4. Motor fuel-dispensing facilities shall comply with Section 406.7.

444.7.1 Weather protection canopies. Where weather protection canopies are provided, they shall be constructed in accordance with Section 415.12.9. Weather protection canopies shall not be located within 15 feet (4572 mm) of a building or combustible material or within 25 feet (7620 mm) of building openings, lot lines, public streets, public alleys or public ways.

444.7.2 Ventilation. Ventilation shall be provided to prevent accumulation of vapors in accordance with Section 444.5.2.6.5.1.

444.7.3 Fire protection. Fire protection shall be in accordance with Section 444.3.

444.7.4 Loading racks. Where provided, loading racks, stairways or platforms shall be constructed of noncombustible materials. Buildings for pumps or for shelter of loading personnel are allowed to be part of the loading rack. Wiring and electrical equipment located within 25 feet (7620 mm) of any portion of the loading rack shall be in accordance with Section 444.2.1.

444.8 Refineries. Plants and portions of plants in which flammable liquids are produced on a scale from crude petroleum, natural gasoline or other hydrocarbon sources shall be in accordance with Section 444.8.1. Petroleum-processing plants and facilities or portions of plants or facilities in which flammable or *combustible liquids* are handled, treated or produced on a commercial scale from crude petroleum, natural gasoline or other hydrocarbon sources shall also be in accordance with API 651, API 653, API 752, API 1615, API 2001, API 2003, API 2009, API 2015, API 2023, API 2201 and API 2350.

444.8.1 Corrosion protection. Above-ground tanks shall be protected against corrosion in accordance with API 651.

444.9 Commercial cooking oil storage. Storage of cooking oil (grease) in commercial cooking operations utilizing above-ground tanks with a capacity greater than

60 gallons (227 L) installed within a building shall comply with Sections 610.2 through 610.7 and NFPA 30. For purposes of this section, cooking oil shall be classified as a Class IIIB liquid unless otherwise determined by testing.

444.9.1 Metallic storage tanks. Metallic cooking oil storage tanks shall be listed in accordance with UL 142 or UL 80 and shall be installed in accordance with the tank manufacturer's instructions.

444.9.2 Nonmetallic storage tanks. Nonmetallic cooking oil storage tanks shall be listed in accordance with UL 2152 and shall be installed in accordance with the tank manufacturer's instructions. Tank capacity shall not exceed 200 gallons (757L) per tank.

444.9.3 Cooking oil storage system components. Cooking oil storage system components shall include but are not limited to piping, connections, fittings, valves, tubing, hose, pumps, vents and other related components used for the transfer of cooking oil, and are permitted to be of either metallic or nonmetallic construction.

444.9.3.1 Design standards. The design, fabrication and assembly of system components shall be suitable for the working pressures, temperatures and structural stresses to be encountered by the components.

444.9.3.2 Components in contact with heated oil. System components that come in contact with heated cooking oil shall be rated for the maximum operating temperatures expected in the system.

444.9.4 Tank venting. Normal and emergency venting shall be provided for cooking oil storage tanks.

444.9.4.1 Normal vents. Normal vents shall be located above the maximum normal liquid line and shall have a minimum effective area not smaller than the largest filling or withdrawal connection. Normal vents shall be permitted to vent inside the building.

444.9.4.2 Emergency vents. Emergency relief vents shall be located above the maximum normal liquid line and shall be in the form of a device or devices that will relieve excessive internal pressure caused by an exposure fire. For nonmetallic tanks, the emergency relief vent shall be allowed to be in the form of construction. Emergency vents shall be permitted to vent inside the building.

444.9.5 Heating of cooking oil. Electrical equipment used for heating cooking oil in cooking oil storage systems shall be listed to UL 499 and shall comply with the *Electrical Code*. Use of electrical immersion heaters shall be prohibited in nonmetallic tanks.

444.9.6 Electrical equipment. Electrical equipment used for the operation of cooking oil storage systems shall comply with the *Electrical Code*.

Section 445 Flammable Gases and Flammable Cryogenic Fluids**OSSC 445**

445.1 Scope. The storage and use of flammable gases and *flammable cryogenic fluids* shall be in accordance with this section, NFPA 2 and NFPA 55. *Compressed gases* shall also comply with Section 440 and *cryogenic fluids* shall also comply with Section 442. *Flammable cryogenic fluids* shall comply with Section 445.5. Hydrogen motor fuel-dispensing stations and repair garages and their associated above-ground hydrogen storage systems shall also be designed and constructed in accordance with Section 406.

Exceptions:

1. Gases used as *refrigerants in refrigeration systems* (see Chapter 28).
2. Liquefied petroleum gases and natural gases regulated by Section 448.
3. Fuel-gas systems and appliances regulated under the *Mechanical Code* other than gaseous hydrogen systems and appliances.
4. Pyrophoric gases in accordance with Section 451.

445.2 Quantities not exceeding the maximum allowable quantity per control area. The storage and use of flammable gases in amounts not exceeding the *maximum allowable quantity per control area* indicated in Section 414.1.6 shall be in accordance with Sections 414 and 445.

445.2.1 Special limitations for indoor storage and use. Flammable gases shall not be stored or used in Group A, E, I or R occupancies or in offices in Group B occupancies.

Exceptions:

1. *Cylinders of nonliquefied compressed gases* not exceeding a capacity of 250 cubic feet (7.08 m³) or liquefied gases not exceeding a capacity of 40 pounds (18 kg) each at *normal temperature and pressure* (NTP) used for maintenance purposes, patient care or operation of equipment.
2. Hydrogen gas systems located in a hydrogen fuel gas room constructed in accordance with Section 421.

445.2.1.1 Medical gases. Medical gas system supply *cylinders* shall be located in medical gas storage rooms or gas cabinets as set forth in Section 440.9.

445.2.1.2 Aggregate quantity. The aggregate quantities of flammable gases used for maintenance purposes and operation of equipment shall not exceed the *maximum allowable quantity per control area* indicated in Table 307.1(1).

445.2.2 Storage containers. *Cylinders and pressure vessels* for flammable gases shall be designed, constructed, installed, tested and maintained in

accordance with Section 440.

445.2.3 Emergency shutoff. Compressed gas systems conveying flammable gases shall be provided with approved manual or automatic emergency shutoff valves that can be activated at each point of use and at each source.

445.2.3.1 Shutoff at source. A manual or automatic fail-safe emergency shutoff valve shall be installed on supply piping at the cylinder or bulk source. Manual or automatic cylinder valves are allowed to be used as the required emergency shutoff valve where the source of supply is limited to unmanifolded cylinder sources.

445.2.3.2 Shutoff at point of use. A manual or automatic emergency shutoff valve shall be installed on the supply piping at the point of use or at a point where the equipment using the gas is connected to the supply system.

445.2.4 Ignition source control. Ignition sources in areas containing flammable gases in storage or in use shall be controlled in accordance with Section 414.10.

Exception: Fuel gas systems connected to building service utilities in accordance with the *Fuel Gas Code*.

445.2.4.1 Static-producing equipment. Static-producing equipment located in flammable gas storage areas shall be grounded.

445.2.4.2 Signs. “No Smoking” signs shall be posted at entrances to rooms and in areas containing flammable gases in accordance with Section 414.10.1.

445.2.5 Electrical. Electrical wiring and equipment shall be installed in accordance with Chapter 27 and the *Electrical Code*.

445.2.5.1 Bonding of electrically conductive materials and equipment. Exposed noncurrent-carrying metal parts, including metal gas piping systems, that are part of flammable gas supply systems located in a hazardous (electrically classified) location shall be bonded to a grounded conductor in accordance with the provisions of the *Electrical Code*.

445.2.5.2 Static-producing equipment. Static-producing equipment located in flammable gas storage or use areas shall be grounded.

445.3 Quantities exceeding the maximum allowable quantity per control area. The storage and use of flammable gases in amounts exceeding the *maximum allowable quantity per control area* indicated in Section 414.1.6 shall be in accordance with Sections 414 and 415 and this section.

445.4 Indoor storage. Indoor storage of flammable gases in amounts exceeding the *maximum allowable quantity per control area* indicated in Table 307.1(1), shall be in accordance with Sections 414 and 415 and this section.

445.4.1 Explosion control. Buildings or portions thereof containing flammable gases shall be provided with explosion control in accordance with Section 919.

445.5 Flammable cryogenic fluids. The storage and use of *flammable cryogenic fluids* shall be in accordance with Sections 445.5.1 through 445.5.1.1.1 and Section 442.

445.5.1 Above-ground tanks for liquid hydrogen. Above-ground tanks for the storage of liquid hydrogen shall be in accordance with Sections 445.5.1.1 and 445.5.1.1.1.

445.5.1.1 Construction of the vacuum jacket (outer vessel). The vacuum jacket used as an outer vessel for storage tanks in liquid hydrogen service shall be of welded steel construction designed to withstand the maximum internal and external pressures to which it will be subjected under operating conditions, including conditions of emergency pressure relief of the annular space between the inner and outer vessels. The jacket shall be designed to withstand a minimum collapsing pressure differential of 30 psi (207 kPa).

445.5.1.1.1 Vacuum-level monitoring. A connection shall be provided on the exterior of the vacuum jacket to allow measurement of the pressure within the annular space between the inner and outer vessels. The connection shall be fitted with a bellows-sealed or diaphragm-type valve equipped with a vacuum gauge tube that is shielded to protect against damage from impact.

445.6 Metal hydride storage systems. The storage and use of *metal hydride storage systems* shall be in accordance with Sections 445.1 through 445.4 and Section 445.6. Those portions of the system that are used as a means to store or supply hydrogen shall also comply with Sections 414, 415 and 440, as applicable.

445.6.1 Classification. The hazard classification of the *metal hydride storage system*, as required by Section 414.1.4.2, shall be based on the hydrogen stored without regard to the *metal hydride* content.

445.6.2 Listed or approved systems. *Metal hydride storage systems* shall be *listed or approved* for the application and designed in a manner that prevents the addition or removal of the *metal hydride* by other than the original equipment manufacturer.

445.6.3 Containers, design and construction. *Compressed gas containers, cylinders* and tanks shall be designed and constructed in accordance with Section 440.

445.6.4 Electrical. Electrical components for *metal hydride storage systems* shall be designed, constructed and installed in accordance with the *Electrical Code*.

445.7 Hydrogen fuel gas rooms. Where required by this code, hydrogen fuel gas rooms shall be designed and constructed in accordance with Sections 445.7.1 through 445.7.6.

445.7.1 Location. Hydrogen fuel gas rooms shall not be located below grade.

445.7.2 Design and construction. Hydrogen fuel gas rooms not exceeding the *maximum allowable quantity per control area* in Table 307.1(1) shall be separated from other areas of the building in accordance with Section 509.1.

445.7.2.1 Pressure control. Hydrogen fuel gas rooms shall be provided with a ventilation system designed to maintain the room at a negative pressure in relation to surrounding rooms and spaces.

445.7.2.2 Windows. Operable windows in interior walls shall not be permitted. Fixed windows shall be permitted where in accordance with Section 716.

445.7.3 Exhaust ventilation. Hydrogen fuel gas rooms shall be provided with mechanical exhaust ventilation in accordance with the applicable provisions of Section 406.8.1.

445.7.4 Gas detection system. Hydrogen fuel gas rooms shall be provided with a gas detection system that complies with Sections 916, 445.7.4.1 and 445.7.4.2.

445.7.4.1 System activation. Activation of a gas detection system alarm shall result in both of the following:

1. Initiation of distinct audible and visible alarm signals both inside and outside the hydrogen fuel gas room.
2. Automatic activation of the mechanical exhaust ventilation system.

445.7.4.2 Failure of the gas detection system. Failure of the gas detection system shall automatically activate the mechanical exhaust ventilation system, stop hydrogen generation and cause a trouble signal to sound at an *approved* location.

445.7.5 Explosion control. Explosion control shall be provided where required by Section 919.

445.7.6 Standby power. Mechanical ventilation and gas detection systems shall be connected to a standby power system in accordance with Section 2702.

Section 446 Flammable Solids**OSSC 446**

446.1 Scope. The storage and use of flammable solids shall be in accordance with this section.

446.2 Quantities not exceeding the maximum allowable quantity per control area. The storage and use of flammable solids in amounts not exceeding the *maximum allowable quantity per control area* as indicated in Section 414.1.6 shall be in accordance with Sections 414 and 446.

446.3 Quantities exceeding the maximum allowable quantity per control area. The storage and use of flammable solids exceeding the *maximum allowable quantity per control area* as indicated in Section 414.1.6 shall be in accordance with Sections 414 and 415 and this section.

446.4 Indoor storage. Indoor storage of flammable solids in amounts exceeding the *maximum allowable quantity per control area* indicated in Table 307.1(1) shall be in accordance with Sections 414 and 415 and this section.

446.4.1 Basement storage. Flammable solids shall not be stored in *basements*.

446.5 Use. The use of flammable solids in amounts exceeding the *maximum allowable quantity per control area* indicated in Table 307.1(1) shall be in accordance with Sections 414 and 415 and this section. The use of *magnesium* shall be in accordance with Section 446.6.

446.6 Magnesium.

446.6.1 Storage of greater than 1,000 cubic feet. *Magnesium* storage in quantities greater than 1,000 cubic feet (28 m³) shall be separated into piles, each not larger than 1,000 cubic feet (28 m³). Piles shall be separated by aisles with a minimum width of not less than the pile height. Such storage shall not be located in nonsprinklered buildings of Type III, IV, or V construction.

446.6.2 Storage of pigs, ingots and billets. The storage of *magnesium* pigs, ingots and billets shall comply with Section 446.6.2.1

446.6.2.1 Indoor storage. Indoor storage of pigs, ingots and billets shall be only on floors of noncombustible construction. Piles shall not be larger than 500,000 pounds (226.8 metric tons) each. Piles shall be separated by aisles with a minimum width of not less than one-half the pile height.

446.6.3 Storage of fine magnesium scrap. The storage of scrap *magnesium* shall comply with Section 446.6.3.1.

446.6.3.1 Storage of 50 to 1,000 cubic feet. Storage of fine *magnesium* scrap in quantities greater than 50 cubic feet (1.4 m³). [six 55-gallon (208 L) steel

drums] shall be separated from other occupancies by an open space of not less than 50 feet (15,240 mm) or by a *fire barrier* constructed in accordance with Section 707.

446.6.4 Use of magnesium. The use of *magnesium* shall comply with Sections 446.6.4.1 through 446.6.4.5.

446.6.4.1 Melting pots. Floors under and around melting pots shall be of noncombustible construction.

446.6.4.2 Dust collection. *Magnesium* grinding, buffing and wire-brushing operations, other than rough finishing of castings, shall be provided with *approved* hoods or enclosures for dust collection that are connected to a liquid-precipitation type of separator that converts dust to sludge without contact (in a dry state) with any high-speed moving parts.

446.6.4.2.1 Duct construction. Connecting ducts or suction tubes shall be completely grounded, as short as possible and without bends. Ducts shall be fabricated and assembled with a smooth interior; with internal lap joints pointing in the direction of airflow; and without unused capped side outlets, pockets or other dead-end spaces that allow an accumulation of dust.

446.6.4.2.2 Independent dust separators. Each machine shall be equipped with an individual dust-separating unit.

Exceptions:

1. One separator is allowed to serve two dust-producing units on multiunit machines.
2. One separator is allowed to serve not more than four portable dust-producing units in a single enclosure or stand.

446.6.4.3 Power supply interlock. Power supply to machines shall be interlocked with exhaust airflow and liquid pressure level or flow. The interlock shall be designed to shut down the machine it serves when the dust removal or separator system is not operating properly.

446.6.4.4 Electrical equipment. Electric wiring, fixtures and equipment in the immediate vicinity of and attached to dust-producing machines, including those used in connection with separator equipment, shall be of *approved* types and shall be *approved* for use in Class II, Division 1 hazardous locations in accordance with the *Electrical Code*.

446.6.4.5 Grounding. Equipment shall be securely grounded by permanent ground wires in accordance with the *Electrical Code*.

Section 447 Highly Toxic and Toxic Materials**OSSC 447**

447.1 Highly toxic and toxic materials. The storage and use of highly toxic and toxic materials shall comply with this section. *Compressed gases* shall also comply with Section 440.

Exception: Display and storage in Group M and storage in Group S occupancies complying with Section 414.2.5.

447.2 Indoor storage and use. The indoor storage and use of highly toxic and toxic materials shall comply with Sections 447.2.1 through 447.2.5.3.

447.2.1 Quantities not exceeding the maximum allowable quantity per control area. The indoor storage or use of highly toxic and toxic solids or liquids in amounts not exceeding the *maximum allowable quantity per control area* indicated in Table 307.1(2) shall be in accordance with Sections 414 and 447.

447.2.2 Quantities exceeding the maximum allowable quantity per control area. The indoor storage or use of highly toxic and toxic solids or liquids in amounts exceeding the *maximum allowable quantity per control area* set forth in Table 307.1(2) shall be in accordance with Section 447, Sections 447.2.3 through 447.2.5.3 and Sections 414 and 415.

447.2.3 Treatment system—highly toxic liquids. Exhaust scrubbers or other systems for processing vapors of highly toxic liquids shall be provided where a spill or accidental release of such liquids can be expected to release highly toxic vapors at NTP. Treatment systems and other processing systems shall be installed in accordance with the *Mechanical Code*.

447.2.4 Indoor storage. Indoor storage of highly toxic and toxic solids and liquids shall comply with Sections 447.2.4.1 and 447.2.4.2.

447.2.4.1 Floors. In addition to the requirements set forth in Section 415.12.8, floors of storage areas where highly toxic and toxic liquids are stored shall be of liquid-tight construction.

447.2.4.2 Separation—highly toxic solids and liquids. In addition to the requirements set forth in Section 414.19, highly toxic solids and liquids in storage shall be located in *approved hazardous materials* storage cabinets or isolated from other *hazardous materials storage* by construction in accordance with this code.

447.2.5 Indoor use. Indoor use of highly toxic and toxic solids and liquids shall comply with Sections 447.2.5.1 through 447.2.5.3.

447.2.5.1 Liquid transfer. Highly toxic and toxic liquids shall be transferred in accordance with Section 415.13.10.

447.2.5.2 Exhaust ventilation for open systems. Mechanical exhaust ventilation shall be provided for highly toxic and toxic liquids used in *open systems* in accordance with Section 415.13.12.1.1.

Exception: Liquids that do not generate highly toxic or toxic fumes, mists or vapors.

447.2.5.3 Exhaust ventilation for closed systems. Mechanical exhaust ventilation shall be provided for highly toxic and toxic liquids used in *closed systems* in accordance with Section 415.13.12.2.1.

Exception: Liquids that do not generate highly toxic or toxic fumes, mists or vapors.

447.2.6 Weather protection for highly toxic liquids and solids—outdoor storage or use. Where overhead weather protection is provided for outdoor storage or use of highly toxic liquids or solids, and the weather protection is attached to a building, the storage or use area shall be either equipped throughout with an *approved automatic sprinkler system*, in accordance with Section 903.3.1.1, or storage or use vessels shall be fire resistive. Weather protection shall be provided in accordance with Section 415.12.9 for storage and Section 415.13.13 for use.

447.3 Highly toxic and toxic compressed gases. The storage and use of highly toxic and toxic *compressed gases* shall comply with this section.

447.3.1 Special limitations for indoor storage and use by occupancy. The indoor storage and use of highly toxic and toxic *compressed gases* in certain occupancies shall be subject to the limitations contained in Sections 447.3.1.1 through 447.3.1.3.

447.3.1.1 Group A, E, I or U occupancies. Toxic and highly toxic *compressed gases* shall not be stored or used within Group A, E, I or U occupancies.

Exception: *Cylinders* not exceeding 20 cubic feet (0.566 m³) at NTP are allowed within gas cabinets or fume hoods.

447.3.1.2 Group R occupancies. Toxic and highly toxic *compressed gases* shall not be stored or used in Group R occupancies.

447.3.1.3 Offices, retail sales and classrooms. Toxic and highly toxic *compressed gases* shall not be stored or used in offices, retail sales or classroom portions of Group B, F, M or S occupancies.

Exception: In classrooms of Group B occupancies, *cylinders* with a capacity not exceeding 20 cubic feet (0.566 m³) at NTP are allowed in gas cabinets or fume hoods.

447.3.2 Gas cabinets. Gas cabinets containing highly toxic or toxic *compressed gases* shall comply with Section 414.13 and the following requirements:

1. The average ventilation velocity at the face of gas cabinet access ports or windows shall be not less than 200 feet per minute (1.02 m/s) with not less than 150 feet per minute (0.76 m/s) at any point of the access port or window.
2. Gas cabinets shall be connected to an exhaust system.
3. Gas cabinets shall not be used as the sole means of exhaust for any room or area.
4. The maximum number of *cylinders* located in a single gas cabinet shall not exceed three, except that cabinets containing *cylinders* not exceeding 1 pound (0.454 kg) net contents are allowed to contain up to 100 *cylinders*.
5. Gas cabinets required by Section 447.3.4 or 447.3.5 shall be equipped with an *approved automatic sprinkler system* in accordance with Section 903.3.1.1. *Alternative fire-extinguishing systems* shall not be used.

447.3.3 Exhausted enclosures. Exhausted enclosures containing highly toxic or toxic *compressed gases* shall comply with Section 414.12 and the following requirements:

1. The average ventilation velocity at the face of the enclosure shall be not less than 200 feet per minute (1.02 m/s) with not less than 150 feet per minute (0.76 m/s) at any point at the face of the enclosure.
2. Exhausted enclosures shall be connected to an exhaust system.
3. Exhausted enclosures shall not be used as the sole means of exhaust for any room or area.
4. Exhausted enclosures required by Section 447.3.4 or 447.3.5 shall be equipped with an *approved automatic sprinkler system* in accordance with Section 903.3.1.1. *Alternative fire-extinguishing systems* shall not be used.

447.3.4 Indoor storage and use. The indoor storage and use of highly toxic or toxic *compressed gases* shall be in accordance with Sections 447.3.4.1 through 447.3.4.2.10.3.

447.3.4.1 Applicability. The applicability of regulations governing the indoor storage and use of highly toxic and toxic *compressed gases* shall be as set forth in Sections 447.3.4.1.1 through 447.3.4.1.3.

447.3.4.1.1 Quantities not exceeding the maximum allowable quantity per control area. The indoor storage or use of highly toxic and toxic gases in amounts not exceeding the *maximum allowable quantity per control area* set forth in Table 307.1(2) shall be in accordance with Sections 414 and 447.

447.3.4.1.2 Quantities exceeding the maximum allowable quantity per control area. The indoor storage or use of highly toxic and toxic gases in amounts exceeding the *maximum allowable quantity per control area* set forth in Table 307.1(2) shall be in accordance with Sections 447.1, 447.3, 447.3.4 and Sections 414 and 415.

447.3.4.1.3 Ozone gas generators. The indoor use of ozone gas-generating equipment shall be in accordance with Section 447.4.

447.3.4.2 General indoor requirements. The general requirements applicable to the indoor storage and use of highly toxic and toxic *compressed gases* shall be in accordance with Sections 447.3.4.2.1 through 447.3.4.2.10.3.

447.3.4.2.1 Cylinder and tank location. *Cylinders* shall be located within gas cabinets, exhausted enclosures or gas rooms. Portable and stationary tanks shall be located within gas rooms or exhausted enclosures.

447.3.4.2.2 Ventilated areas. The room or area in which gas cabinets or exhausted enclosures are located shall be provided with exhaust ventilation. Gas cabinets or exhausted enclosures shall not be used as the sole means of exhaust for any room or area.

447.3.4.2.3 Leaking cylinders and tanks. One or more gas cabinets or exhausted enclosures shall be provided to handle leaking *cylinders, containers* or tanks.

Exceptions:

1. Where *cylinders, containers* or tanks are located within gas cabinets or exhausted enclosures.
2. Where *approved containment vessels* or *containment systems* are provided in accordance with all of the following:
 - 2.1. *Containment vessels* or *containment systems* shall be capable of fully containing or terminating a release.
 - 2.2. Trained personnel shall be available at an *approved* location.
 - 2.3. *Containment vessels* or *containment systems* shall be capable of being transported to the leaking *cylinder, container* or tank.

447.3.4.2.3.1 Location. Gas cabinets and exhausted enclosures shall be located in gas rooms and connected to an exhaust system.

447.3.4.2.4 Local exhaust for portable tanks. A means of local exhaust shall be provided to capture leaks from *portable tanks*. The local

exhaust shall consist of portable ducts or collection systems designed to be applied to the site of a leak in a valve or fitting on the tank. The local exhaust system shall be located in a gas room. Exhaust shall be directed to a treatment system in accordance with Section 447.3.4.2.7.

447.3.4.2.5 Piping and controls—stationary tanks. Piping and controls on stationary tanks shall comply with the following requirements:

1. Pressure relief devices shall be vented to a treatment system designed in accordance with Section 447.3.4.2.7.
2. Filling or dispensing connections shall be provided with a means of local exhaust. Such exhaust shall be designed to capture fumes and vapors. The exhaust shall be directed to a treatment system in accordance with Section 447.3.4.2.7.
3. Stationary tanks shall be provided with a means of *excess flow control* on all tank inlet or outlet connections.

Exceptions:

1. Inlet connections designed to prevent backflow.
2. Pressure relief devices.

447.3.4.2.6 Gas rooms. Gas rooms shall comply with Section 414.11 and both of the following requirements:

1. The exhaust ventilation from gas rooms shall be directed to an exhaust system.
2. Gas rooms shall be equipped with an *approved automatic sprinkler system*. Alternative fire-extinguishing systems shall not be used.

447.3.4.2.7 Treatment systems. The exhaust ventilation from gas cabinets, exhausted enclosures and gas rooms, and local exhaust systems required in Sections 447.3.4.2.4 and 447.3.4.2.5 shall be directed to a treatment system. The treatment system shall be utilized to handle the accidental release of gas and to process exhaust ventilation. The treatment system shall be designed in accordance with Sections 447.3.4.2.7.1 through 447.3.4.2.7.4 and Section 510 of the *Mechanical Code*.

Exceptions:

1. Highly toxic and toxic gases—storage. A treatment system is not required for *cylinders, containers and tanks* in storage where all of the following controls are provided:
 - 1.1. Valve outlets are equipped with gastight outlet plugs or caps.
 - 1.2. Handwheel-operated valves have handles secured to prevent

movement.

1.3. *Approved containment vessels or containment systems* are provided in accordance with Section 447.3.4.2.3.

2. Toxic gases—use. Treatment systems are not required for toxic gases supplied by *cylinders or portable tanks* not exceeding 1,700 pounds (772 kg) water capacity where a gas detection system complying with Section 447.3.4.2.10 and *listed or approved* automatic-closing fail-safe valves are provided. The gas detection system shall have a sensing interval not exceeding .5 minutes. Automatic-closing fail-safe valves shall be located immediately adjacent to *cylinder valves* and shall close when gas is detected at the *permissible exposure limit (PEL)* by a gas sensor monitoring the exhaust system at the point of discharge from the gas cabinet, exhausted enclosure, ventilated enclosure or gas room.

447.3.4.2.7.1 Design. Treatment systems shall be capable of diluting, adsorbing, absorbing, containing, neutralizing, burning or otherwise processing the contents of the largest single vessel of compressed gas. Where a total *containment system* is used, the system shall be designed to handle the maximum anticipated pressure of release to the system when it reaches equilibrium.

447.3.4.2.7.2 Performance. Treatment systems shall be designed to reduce the maximum allowable discharge concentrations of the gas to one-half the IDLH at the point of discharge to the atmosphere. Where more than one gas is emitted to the treatment system, the treatment system shall be designed to handle the worst-case release based on the release rate, the quantity and the IDLH for all *compressed gases* stored or used.

447.3.4.2.7.3 Sizing. Treatment systems shall be sized to process the maximum worst-case release of gas based on the maximum flow rate of release from the largest vessel utilized. The entire contents of the largest *compressed gas* vessel shall be considered.

447.3.4.2.7.4 Stationary tanks. Stationary tanks shall be labeled with the maximum rate of release for the *compressed gas* contained based on valves or fittings that are inserted directly into the tank. Where multiple valves or fittings are provided, the maximum flow rate of release for valves or fittings with the highest flow rate shall be indicated. Where liquefied *compressed gases* are in contact with valves or fittings, the liquid flow rate shall be utilized for computation purposes. Flow rates indicated on the label shall be converted to cubic feet per minute (cfm/min) (m³/s) of gas at NTP.

447.3.4.2.8 Emergency power. Emergency power shall be provided for the following systems in accordance with Chapter 27:

1. Exhaust ventilation system.
2. Treatment system.
3. Gas detection system.
4. Smoke detection system.
5. Temperature control system.
6. Fire alarm system.
7. Emergency alarm system.

447.3.4.2.8.1 Fail-safe engineered systems. Emergency power shall not be required for mechanical exhaust ventilation, treatment systems and temperature control systems where *approved* fail-safe engineered systems are installed.

447.3.4.2.9 Automatic fire detection system—highly toxic compressed gases. An *approved* automatic fire detection system shall be installed in rooms or areas where highly toxic *compressed gases* are stored or used. Activation of the detection system shall sound a local alarm. The fire detection system shall comply with Section 907.

447.3.4.2.10 Gas detection system. A gas detection system complying with Section 916 shall be provided to detect the presence of gas at or below the PEL or ceiling limit of the gas for which detection is provided. The system shall be capable of monitoring the discharge from the treatment system at or below one-half the IDLH limit and shall initiate a response in accordance with Sections 447.3.4.2.10.1 through 447.3.4.2.10.3 if the gas detection alarm is activated.

Exception: A gas detection system is not required for toxic gases where the physiological warning threshold level for the gas is at a level below the accepted PEL for the gas.

447.3.4.2.10.1 Alarms. The gas detection system shall initiate a local alarm and transmit a signal to a constantly attended control station when a short-term hazard condition is detected. The alarm shall be both audible and visible and shall provide warning both inside and outside the area where gas is detected. The audible alarm shall be distinct from all other alarms.

Exception: Signal transmission to a constantly attended control station is not required where not more than one *cylinder* of highly toxic or toxic gas is stored.

447.3.4.2.10.2 Shut off of gas supply. The gas detection system shall automatically close the shutoff valve at the source on gas supply piping and tubing related to the system being monitored for whichever gas is detected.

Exception: Automatic shutdown is not required for reactors utilized for the production of highly toxic or toxic *compressed gases* where such reactors are:

1. Operated at pressures less than 15 pounds per square inch gauge (psig) (103.4 kPa).
2. Constantly attended.
3. Provided with *emergency shutoff valves* that have *ready access*.

447.3.4.2.10.3 Valve closure. Automatic closure of shutoff valves shall be in accordance with the following:

1. Where the gas detection sampling point initiating the gas detection system alarm is within a gas cabinet or exhausted enclosure, the shutoff valve in the gas cabinet or exhausted enclosure for the specific gas detected shall automatically close.
2. Where the gas detection sampling point initiating the gas detection system alarm is within a gas room and *compressed gas containers* are not in gas cabinets or exhausted enclosures, the shutoff valves on all gas lines for the specific gas detected shall automatically close.
3. Where the gas detection sampling point initiating the gas detection system alarm is within a piping distribution manifold enclosure, the shutoff valve for the *container* of specific *compressed gas* detected supplying the manifold shall automatically close.

Exception: Where the gas detection sampling point initiating the gas detection system alarm is at a use location or within a gas valve enclosure of a branch line downstream of a piping distribution manifold, the shutoff valve in the gas valve enclosure for the branch line located in the piping distribution manifold enclosure shall automatically close.

447.3.5 Outdoor storage weather protection for portable tanks and cylinders. Where weather protection in accordance with Section 415.12.9 is provided for *portable tanks* and *cylinders* located outdoors and not within gas cabinets or exhausted enclosures, the storage area shall be equipped with an *approved automatic sprinkler system* in accordance with Section 903.3.1.1.

Exception: An *automatic sprinkler system* is not required where:

1. All materials under the weather protection structure, including *hazardous materials* and the *containers* in which they are stored, are noncombustible.

2. The weather protection structure is located not less than 30 feet (9144 mm) from combustible materials.

447.4 Ozone gas generators. Ozone gas generators having a maximum ozone-generating capacity of 0.5 pound (0.23 kg) or more over a 24-hour period shall be in accordance with Sections 447.4.1 through 447.4.5.

Exceptions:

1. Ozone-generating equipment used in Group R-3 occupancies.
2. Ozone-generating equipment where used in Group H-5 occupancies where in compliance with Sections 414 and 415 and the other provisions in this section for highly toxic gases.

447.4.1 Design. Ozone gas generators shall be designed, fabricated and tested in accordance with NEMA 250.

447.4.2 Location. Ozone gas generators shall be located in *approved* cabinets or ozone generator rooms in accordance with Section 447.4.2.1 or 447.4.2.2.

Exception: An ozone gas generator within an *approved pressure vessel* where located outdoors.

447.4.2.1 Cabinets. Ozone gas cabinets shall be constructed of *approved* materials and compatible with ozone. Cabinets shall display an *approved* sign stating: OZONE GAS GENERATOR—HIGHLY TOXIC—OXIDIZER.

Cabinets shall be braced for seismic activity in accordance with this code.

Cabinets shall be mechanically ventilated in accordance with the *Mechanical Code* with not less than six air changes per hour.

The average velocity of ventilation at makeup air openings with cabinet doors closed shall be not less than 200 feet per minute (1.02 m/s).

447.4.2.2 Ozone gas generator rooms. Ozone gas generator rooms shall be mechanically ventilated in accordance with the *Mechanical Code* with not less than six air changes per hour. Ozone gas generator rooms shall be equipped with a gas detection system complying with Section 916 that will shut off the generator and sound a local alarm when concentrations above the *permissible exposure limit* (PEL) occur.

Ozone gas generator rooms shall not be normally occupied and such rooms shall be kept free of combustible and *hazardous materials storage*. Room access doors shall display an *approved* sign stating: OZONE GAS GENERATOR—HIGHLY TOXIC—OXIDIZER.

447.4.3 Materials. Materials shall be compatible with ozone and shall be rated for the design operating pressures.

447.4.3.1 Identification. Piping shall be identified with the following: OZONE GAS—HIGHLY TOXIC—OXIDIZER.

447.4.4 Automatic shutdown. Ozone gas generators shall be designed to shut down automatically under the following conditions:

1. When the dissolved ozone concentration in the water being treated is above saturation when measured at the point where the water is exposed to the atmosphere.
2. When the process using generated ozone is shut down.
3. Failure of the ventilation system for the cabinet or ozone generator room.
4. Failure of the gas detection system in an ozone gas generator room.

447.4.5 Manual shutdown. Manual shutdown controls shall be provided at the generator and, where in a room, within 10 feet (3048 mm) of the main *exit* or *exit access door*.

Section 448 Liquefied Petroleum Gases**OSSC 448**

448.1 Scope. Storage, handling and transportation of liquefied petroleum gas (LP-gas) and the installation of LP-gas equipment pertinent to systems for such uses shall comply with this section and NFPA 58. Properties of LP-gases shall be determined in accordance with Appendix B of NFPA 58.

448.2 Storage of portable LP-gas containers awaiting use or resale. Storage of portable LP-gas containers of 1,000 pounds (454 kg) or less, whether filled, partially filled or empty, at consumer sites or distribution points and for resale by dealers or resellers, shall comply with Sections 448.2 through 448.11.2.

Exceptions:

1. LP-gas containers that have not previously been in LP-gas service.
2. LP-gas containers at distribution plants.
3. LP-gas containers at consumer sites or distribution points, which are connected for use.

448.3 Position. LP-gas containers in storage having individual water capacity greater than 2.7 pounds (1.2 kg) [nominal 1-pound (0.454 kg) LP-gas capacity] shall be positioned with the pressure relief valve in direct communication with the vapor space of the container.

448.4 Separation from means of egress. LP-gas containers stored in buildings in accordance with Sections 448.9 and 448.11 shall not be located near exit access doors, exits, stairways or in areas normally used, or intended to be used, as a means of egress.

448.5 Quantity. Empty LP-gas containers that have been in LP-gas service shall be considered as full containers for the purpose of determining the maximum quantities of LP-gas allowed in Sections 448.9 and 448.11.

448.6 Storage on roofs. LP-gas containers that are not connected for use shall not be stored on roofs.

448.7 Storage in basement, pit or similar location. LP-gas containers shall not be stored in a basement, pit or similar location where heavier-than-air gas might collect. LP-gas containers shall not be stored in above-grade underfloor spaces or basements unless such location is provided with an approved means of ventilation.

Exception: Department of Transportation (DOTn) specification cylinders with a maximum water capacity of 2.7 pounds (1.2 kg) for use in completely self-contained hand torches and similar applications. The quantity of LP-gas shall not exceed 20 pounds (9 kg).

448.8 Protection of valves on LP-gas containers in storage. LP-gas DOTn cylinder valves shall be protected by screw-on-type caps or collars that shall be securely in

place on all containers stored, regardless of whether they are full, partially full or empty. Container and tank outlet valves shall be closed or plugged.

448.9 Storage within buildings open to the public. Department of Transportation (DOTn) specification cylinders with maximum water capacity of 2.7 pounds (1.2 kg) used in completely self-contained hand torches and similar applications are allowed to be stored or displayed in a building open to the public. The quantity of LP-gas shall not exceed 200 pounds (91 kg) except as provided in Section 448.11.

448.10 Storage within buildings not open to the public. The maximum quantity allowed in one storage location in buildings not open to the public, such as industrial buildings, shall not exceed a water capacity of 735 pounds (334 kg) [nominal 300 pounds (136 kg) of LP-gas]. Where additional storage locations are required on the same floor within the same building, they shall be separated by not less than 300 feet (91.440 mm). Storage beyond these limitations shall comply with Section 448.11.

448.10.1 Quantities on equipment and vehicles. LP-gas containers carried as part of service equipment on highway mobile vehicles need not be considered in the total storage capacity in Section 448.10, provided that such vehicles are stored in private garages and do not carry more than three LP-gas containers with an aggregate LP-gas capacity not exceeding 100 pounds (45.4 kg) per vehicle. LP-gas container valves shall be closed.

448.11 Storage within rooms used for gas manufacturing. Storage within buildings or rooms used for gas manufacturing, gas storage, gas-air mixing and vaporization, and compressors not associated with liquid transfer shall comply with Sections 448.11.1 and 448.11.2.

448.11.1 Quantity limits. The maximum quantity of LP-gas shall be 10,000 pounds (4540 kg).

448.11.2 Construction. The construction of such buildings and rooms shall comply with requirements for Group H occupancies, Chapter 10 of NFPA 58 and both of the following:

1. Adequate vents shall be provided to the outside at both top and bottom, located not less than 5 feet (1524 mm) from building openings.
2. The entire area shall be classified for the purposes of ignition source control in accordance with Section 6.25 of NFPA 58.

Section 449 Organic Peroxides**OSSC 449**

449.1 Scope. The storage and use of organic peroxides shall be in accordance with this section and Sections 414 and 415.

Unclassified detonable organic peroxides that are capable of *detonation* in their normal shipping *containers* under conditions of fire exposure shall be stored in accordance with Section 443.

449.2 Quantities not exceeding the maximum allowable quantity per control area. The storage and use of organic peroxides in amounts not exceeding the *maximum allowable quantity per control area* indicated in Section 414.1.15 shall be in accordance with Section 414 and this section.

449.2.1 Special limitations for indoor storage and use by occupancy. The indoor storage and use of organic peroxides shall be in accordance with Sections 449.2.1.1 through 449.2.1.4.

449.2.1.1 Group A, E, I or U occupancies. In Group A, E, I or U occupancies, any amount of unclassified detonable and Class I organic peroxides shall be stored in accordance with the following:

1. Unclassified detonable and Class I organic peroxides shall be stored in *hazardous materials* storage cabinets complying with Section 414.14.
2. The *hazardous materials* storage cabinets shall not contain other storage.

449.2.1.2 Group R occupancies. Unclassified detonable and Class I organic peroxides shall not be stored or used within Group R occupancies.

449.2.1.3 Group B, F, M or S occupancies. Unclassified detonable and Class I organic peroxides shall not be stored or used in offices or in retail sales areas of Group B, F, M or S occupancies.

449.2.1.4 Classrooms. In classrooms in Group B, F or M occupancies, any amount of unclassified detonable and Class I organic peroxides shall be stored in accordance with the following:

1. Unclassified detonable and Class I organic peroxides shall be stored in *hazardous materials* storage cabinets complying with Section 414.14.
2. The *hazardous materials* storage cabinets shall not contain other storage.

449.3 Quantities exceeding the maximum allowable quantity per control area. The storage and use of organic peroxides in amounts exceeding the *maximum allowable quantity per control area* indicated in Section 414.1.6 shall be in accordance with Sections 414 and 415 and this section.

449.4 Indoor storage. Indoor storage of organic peroxides in amounts exceeding the *maximum allowable quantity per control area* indicated in Table 307.1(1) shall be in accordance with Sections 414 and 415 and this section.

Indoor storage of unclassified detonable organic peroxides that are capable of *detonation* in their normal shipping *containers* under conditions of fire exposure shall be stored in accordance with Section 443.

449.4.1 Detached storage. Storage of organic peroxides shall be in detached buildings where required by Section 415.6.5.

449.4.2 Distance from detached buildings to exposures. Detached storage buildings for Class I, II, III, IV and V organic peroxides shall be located in accordance with Table 449.4.2. Detached buildings containing quantities of unclassified detonable organic peroxides in excess of those set forth in Table 415.6.5 shall be located in accordance with Table 443.2.1(2).

449.4.3 Liquid-tight floor. In addition to the requirements of Section 415.12.8, floors of storage areas shall be of liquid-tight construction.

449.4.4 Electrical wiring and equipment. Electrical wiring and equipment in storage areas for Class I or II organic peroxides shall comply with the requirements for electrical Class I, Division 2 locations.

449.4.5 Smoke detection. An *approved* supervised smoke detection system in accordance with Section 907 shall be provided in rooms or areas where Class I, II or III organic peroxides are stored. Activation of the smoke detection system shall sound a local alarm.

Exception: A smoke detection system shall not be required in detached storage buildings equipped throughout with an *approved* automatic fire-extinguishing system complying with Chapter 9.

449.4.6 Maximum quantities. Maximum allowable quantities per building in a mixed-occupancy building shall not exceed the amounts set forth in Table 415.6.5. Maximum allowable quantities per building in a detached storage building shall not exceed the amounts specified in Table 449.4.2.

449.4.7 Storage arrangement. Storage arrangements for organic peroxides shall be in accordance with Table 449.4.7 and shall comply with all of the following:

1. *Containers* and packages in storage areas shall be closed.
2. Bulk storage shall not be in piles or bins.
3. A minimum 2-foot (610 mm) clear space shall be maintained between storage and uninsulated metal walls.
4. Fifty-five-gallon (208 L) drums shall not be stored more than one drum high.

449.4.8 Location in building. The storage of Class I or II organic peroxides shall be on the ground floor. Class III organic peroxides shall not be stored in basements.

449.4.9 Contamination. Organic peroxides shall be stored in their original DOTn shipping containers.

449.4.10 Explosion control. Indoor storage rooms, areas and buildings containing unclassified detonable and Class I organic peroxides shall be provided with explosion control in accordance with Section 919.

449.4.11 Standby power. Standby power shall be provided in accordance with Section 2702 for the following systems used to protect Class I and unclassified detonable organic peroxide:

1. Exhaust ventilation system.
2. Treatment system.
3. Smoke detection system.
4. Temperature control system.
5. Fire alarm system.
6. Emergency alarm system.

449.4.11.1 Fail-safe engineered systems. Standby power shall not be required for mechanical exhaust ventilation, treatment systems and temperature control systems where *approved* fail-safe engineered systems are installed.

449.5 Use. The use of organic peroxides in amounts exceeding the *maximum allowable quantity per control area* indicated in Table 307.1(1) or 307.1(3) shall be in accordance with Sections 414 and 415 and this section.

Section 450 Oxidizers, Oxidizing Gases And Oxidizing Cryogenic Fluids

OSSC 450

450.1 Scope. The storage and use of oxidizing materials shall be in accordance with this section and Sections 414 and 415. Oxidizing gases shall also comply with Section 440. Oxidizing *cryogenic fluids* shall also comply with Section 442.

Exceptions:

1. Display and storage in Group M and storage in Group S occupancies complying with Section 414.2.5.
2. *Bulk oxygen systems* at industrial and institutional consumer sites shall be in accordance with NFPA 55.

450.2 Quantities not exceeding the maximum allowable quantity per control area. The storage and use of oxidizing materials in amounts not exceeding the *maximum allowable quantity per control area* indicated in Section 414.1.6 shall be in accordance with Sections 414 and 450. Oxidizing gases shall also comply with Section 440.

450.2.1 Special limitations for indoor storage and use by occupancy. The indoor storage and use of oxidizing materials shall be in accordance with Sections 450.2.1.1 through 450.2.1.3.

450.2.1.1 Class 4 liquid and solid oxidizers. The storage and use of Class 4 liquid and solid oxidizers shall comply with Sections 450.2.1.1.1 through 450.2.1.1.4.

450.2.1.1.1 Group A, E, I or U occupancies. In Group A, E, I or U occupancies, any amount of Class 4 liquid and solid oxidizers shall be stored in accordance with the following:

1. Class 4 liquid and solid oxidizers shall be stored in *hazardous materials* storage cabinets complying with Section 414.14.

2. The *hazardous materials* storage cabinets shall not contain other storage.

450.2.1.1.2 Group R occupancies. Class 4 liquid and solid oxidizers shall not be stored or used within Group R occupancies.

450.2.1.1.3 Offices and retail sales areas. Class 4 liquid and solid oxidizers shall not be stored or used in offices or retail sales areas of Group B, F, M or S occupancies.

450.2.1.1.4 Classrooms. In classrooms of Group B, F or M occupancies, any amount of Class 4 liquid and solid oxidizers shall be stored in accordance with the following:

1. Class 4 liquid and solid oxidizers shall be stored in *hazardous materials* storage cabinets complying with Section 414.14.
2. *Hazardous materials* storage cabinets shall not contain other storage.

450.2.1.3 Oxidizing gases. Except for *cylinders* of nonliquefied *compressed gases* not exceeding a capacity of 250 cubic feet (7 m³) or liquefied *compressed gases* not exceeding a capacity of 46 pounds (21 kg) each used for maintenance purposes, patient care or operation of equipment, oxidizing gases shall not be stored or used in Group A, E, I or R occupancies or in offices in Group B occupancies.

The aggregate quantities of gases used for maintenance purposes and operation of equipment shall not exceed the *maximum allowable quantity per control area* listed in Table 307.1(1).

Medical gas systems and medical gas supply *cylinders* shall also be in accordance with Section 440.9.

**TABLE 449.4.2
ORGANIC PEROXIDES—DISTANCE TO EXPOSURES FROM DETACHED STORAGE BUILDINGS OR OUTDOOR STORAGE AREAS**

ORGANIC PEROXIDE CLASS	MAXIMUM STORAGE QUANTITY (POUNDS) AT MINIMUM SEPARATION DISTANCE					
	Distance to buildings, lot lines, public streets, public alleys, public ways or means of egress			Distance between individual detached storage buildings		
	50 feet	100 feet	150 feet	20 feet	75 feet	100 feet
I	2,000	20,000	175,000	2,000	20,000	175,000
II	100,000	200,000	No Limit	100,000 ^a	No Limit	No Limit
III	200,000	No Limit	No Limit	200,000 ^a	No Limit	No Limit
IV	No Limit	No Limit	No Limit	No Limit	No Limit	No Limit
V	No Limit	No Limit	No Limit	No Limit	No Limit	No Limit

For SI: 1 foot = 304.8 mm, 1 pound = 0.454 kg.

a. Where the amount of organic peroxide stored exceeds this amount, the minimum separation shall be 50 feet.

**TABLE 449.4.7
STORAGE OF ORGANIC PEROXIDES**

ORGANIC PEROXIDE CLASS	PILE CONFIGURATION				MAXIMUM QUANTITY PER BUILDING
	Maximum width (feet)	Maximum height (feet)	Minimum distance to next pile (feet)	Minimum distance to walls (feet)	
I	6	8	4a	4b	Note c
II	10	8	4a	4b	Note c
III	10	8	4a	4b	Note c
IV	16	10	3a, d	4b	No Requirement
V	No Requirement	No Requirement	No Requirement	No Requirement	No Requirement

For SI: 1 foot = 304.8 mm.

- a. Not less than one main aisle with a minimum width of 8 feet shall divide the storage area.
- b. Distance to noncombustible walls is allowed to be reduced to 2 feet.
- c. See Table 449.4.2 for maximum quantities.
- d. The distance shall be not less than one-half the pile height.

450.2.2 Class 1 oxidizer storage configuration. The storage configuration of Class 1 liquid and solid oxidizers shall be as set forth in Table 450.2.2.

450.2.1.2 Class 3 liquid and solid oxidizers. Not more than 220 pounds (99 kg) of solid or 22 gallons (83 L) of liquid Class 3 oxidizer allowed in storage and use where such materials are necessary for maintenance purposes or operation of equipment. The oxidizers shall be stored in approved containers and in an approved manner.

450.3 Indoor storage. Indoor storage of oxidizing materials in amounts exceeding the maximum allowable quantity per control area indicated in Table 307.1(1) shall be in accordance with Sections 414 and 415 and this section.

450.3.1 Explosion control. Indoor storage rooms, areas and buildings containing Class 4 liquid or solid

oxidizers shall be provided with explosion control in accordance with Section 919.

450.3.2 Automatic sprinkler system. The automatic sprinkler system for oxidizer storage shall be designed in accordance with NFPA 400.

450.3.3 Liquid-tight floor. In addition to Section 415.12.8, floors of storage areas for liquid and solid oxidizers shall be of liquid-tight construction.

450.3.4 Smoke detection. An approved supervised smoke detection system in accordance with Section 907 shall be installed in liquid and solid oxidizer storage areas. Activation of the smoke detection system shall sound a local alarm.

Exception: Detached storage buildings protected by an approved automatic fire-extinguishing system.

**TABLE 450.2.2
STORAGE OF CLASS 1, 2 AND 3 OXIDIZER LIQUIDS AND SOLIDS**

STORAGE CONFIGURATION	LIMITS (feet)		
	Class 1	Class 2	Class 3
Piles		16	12
Maximum width	24	Note c	Note c
Maximum height	20	8	8
Maximum distance to aisle	12	Note a	Note a
Minimum distance to next pile ^a	4 ^a	2	4
Minimum distance to walls ^b	2 ^b	2	4
Maximum quantity per pile	200 tons	MAQ	NA
Maximum quantity per building	No Limit	Note d	Note d

For SI: 1 foot = 304.8 mm, 1 pound = 0.454 kg, 1 ton = 0.907185 metric ton.

MAQ = Maximum allowable quantity.

NA = Not applicable

- a. The minimum aisle width shall be equal to the pile height, but not less than 4 feet and not greater than 8 feet.
- b. There shall not be a minimum distance from the pile to a wall for amounts less than 9,000 pounds.

450.3.5 Storage conditions. The maximum quantity of oxidizers per building in storage buildings shall not exceed those quantities set forth in Tables 450.3.5(1) through 450.3.5(3).

The storage configuration for liquid and solid oxidizers shall be as set forth in Table 450.2.2 and Tables 450.3.5(1) through 450.3.5(3).

Class 2 oxidizers shall not be stored in *basements* except where such storage is in stationary tanks.

Class 3 and 4 oxidizers in amounts exceeding the *maximum allowable quantity per control area* set forth in Section 414.1.6 shall be stored on the ground floor only.

**TABLE 450.3.5(1)
STORAGE OF CLASS 2 OXIDIZER LIQUIDS AND SOLIDS**

STORAGE CONFIGURATION	LIMITS	
	Group H occupancy storage	Detached storage
Piles	25 feet	25 feet
Maximum width	Note a	Note a
Maximum height	12 feet	12 feet
Maximum distance to aisle	Note b	Note b
Minimum distance to next pile	2 feet ^c	2 feet ^c
Minimum distance to walls		
Maximum quantity per pile	100 tons	100 tons
Maximum quantity per building	2,000 tons	No Limit

For SI: 1 foot = 304.8 mm, 1 pound = 0.454 kg, 1 ton = 0.907185 metric ton, MAQ = Maximum Allowable Quantity.

- a. Maximum storage height in nonsprinklered buildings is limited to 6 feet. In sprinklered buildings, see NFPA 400 for storage heights based on ceiling sprinkler protection.
- b. The minimum aisle width shall be equal to the pile height, but not less than 4 feet and not greater than 8 feet.
- c. For protection level and detached storage under 4,500 pounds, there shall not be a minimum separation distance between the pile and any wall.

**TABLE 450.3.5(2)
STORAGE OF CLASS 3 OXIDIZER LIQUIDS AND SOLIDS**

STORAGE CONFIGURATION	LIMITS	
	Group H occupancy storage	Detached storage
Piles	16 feet	20 feet
Maximum width	Note a	Note a
Maximum height	10 feet	10 feet
Maximum distance to aisle	Note b	Note b
Minimum distance to next pile	4 feet ^c	4 feet ^c
Minimum distance to walls		
Maximum quantity per pile	30 tons	100 tons
Maximum quantity per building	1,200 tons	No Limit

For SI: 1 foot = 304.8 mm, 1 pound = 0.454 kg, 1 ton = 0.907185 metric ton, MAQ = Maximum Allowable Quantity, NA = Not Available.

- a. Maximum storage height in nonsprinklered buildings is limited to 6 feet. In sprinklered buildings, see NFPA 400 for storage heights based on ceiling sprinkler protection.
- b. The minimum aisle width shall be equal to the pile height, but not less than 4 feet and not greater than 8 feet.
- c. For protection level and detached storage under 2,300 pounds, there shall not be a minimum separation distance between the pile and any wall.

**TABLE 450.3.5(3)
STORAGE OF CLASS 4 OXIDIZER LIQUIDS AND SOLIDS**

STORAGE CONFIGURATION	LIMITS (feet)
Piles	
Maximum length	10
Maximum width	4
Maximum height	8
Minimum distance to next pile	8
Maximum quantity per building	No Limit

For SI: 1 foot = 304.8 mm.

450.3.6 Separation of Class 4 oxidizers from other materials. In addition to the requirements in Section 414.19, Class 4 oxidizer liquids and solids shall be separated from other *hazardous materials* by not less than a 1-hour fire barrier or stored in *hazardous materials* storage cabinets.

450.3.7 Contamination. Liquid and solid oxidizers shall not be stored on or against combustible surfaces. Liquid and solid oxidizers shall be stored in a manner to prevent contamination.

450.3.8 Detached storage. Storage of liquid and solid oxidizers shall be in detached buildings where required by Section 415.6.5.

450.3.8.1 Separation distance. Detached storage buildings for Class 4 oxidizer liquids and solids shall be located not less than 50 feet (15,240 mm) from other *hazardous materials* storage.

450.4 Use. The use of oxidizers in amounts exceeding the *maximum allowable quantity per control area* indicated in Table 307.1(1) or 307.1(3) shall be in accordance with Sections 414 and 415 and this section. Oxidizing gases shall also comply with Section 440.

Section 451 Pyrophoric Materials

OSSC 451

451.1 Scope. The storage and use of pyrophoric materials shall be in accordance with this section. *Compressed gases* shall also comply with Section 440.

451.2 Quantities not exceeding the maximum allowable quantity per control area. The storage and use of pyrophoric materials in amounts not exceeding the *maximum allowable quantity per control area* indicated in Section 414.1.6 shall be in accordance with Sections 414 and 451.

451.3 Quantities exceeding the maximum allowable quantity per control area. The storage and use of pyrophoric materials in amounts exceeding the *maximum allowable quantity per control area* indicated in Section 414.1.6 shall be in accordance with Sections 414 and 415 and this section.

451.4 Indoor storage. Indoor storage of pyrophoric materials in amounts exceeding the *maximum allowable quantity per control area* indicated in Table 307.1(1) shall be in accordance with Sections 414 and 415 and this section.

The storage of silane gas, and gas mixtures with a silane concentration of 1.37 percent or more by volume, shall be in accordance with CGA G-13.

451.4.1 Liquid-tight floor. In addition to the requirements of Section 415.12.8, floors of storage areas containing pyrophoric liquids shall be of liquid-tight construction.

451.4.2 Pyrophoric solids and liquids. Storage of pyrophoric solids and liquids shall be limited to a maximum area of 100 square feet (9.3 m²) per pile. Storage shall not exceed 5 feet (1524 mm) in height. Individual *containers* shall not be stacked.

Aisles between storage piles shall be not less than 10 feet (3048 mm) in width.

Individual tanks or *containers* shall not exceed 500 gallons (1893 L) in capacity.

451.4.3 Pyrophoric gases. Storage of pyrophoric gases shall be in detached buildings where required by Section 415.6.5.

451.4.4 Separation from incompatible materials. In addition to the requirements of Section 414.1.9, indoor storage of pyrophoric materials shall be isolated from incompatible *hazardous materials* by 1-hour *fire barriers* with openings protected in accordance with this code.

Exception: Storage in *approved hazardous materials* storage cabinets constructed in accordance with Section 414.14.

451.4.5 Weather protection. Where overhead construction is provided for sheltering outdoor storage areas of pyrophoric materials, the storage areas shall be provided with *approved* automatic fire-extinguishing system protection.

451.5 Use. The use of pyrophoric materials in amounts exceeding the *maximum allowable quantity per control area* indicated in Table 307.1(1) or 307.1(3) shall be in accordance with Sections 414 and 415 and this section.

451.5.1 Weather protection. Where overhead construction is provided for sheltering of outdoor use areas of pyrophoric materials, the use areas shall be provided with *approved* automatic fire-extinguishing system protection.

451.5.2 Silane gas. The use of silane gas, and gas mixtures with a silane concentration of 1.37 percent or more by volume, shall be in accordance with CGA G-13.

Section 452 Pyroxylin (Cellulose Nitrate) Plastics

OSSC 452

452.1 Scope. This section shall apply to the storage and handling of plastic substances, materials or compounds with cellulose nitrate as a base, by whatever name known, in the form of blocks, sheets, tubes or fabricated shapes.

Cellulose nitrate motion picture film shall comply with the requirements of Section 409.

452.2 Displays. Cellulose nitrate (pyroxylin) plastic articles are allowed to be placed on tables not more than 3 feet (914 mm) wide and 10 feet (3048 mm) long. Tables shall be spaced not less than 3 feet (914 mm) apart. Where articles are displayed on counters, they shall be arranged in a like manner.

452.3 Space under tables. Spaces underneath tables shall be kept free from storage of any kind and accumulation of paper, refuse and other combustible material.

452.4 Location. Sales or display tables shall be so located that in the event of a fire at the table, the table will not interfere with free means of egress from the room in not less than one direction.

452.5 Lighting. Lighting shall not be located directly above cellulose nitrate (pyroxylin) plastic material, unless provided with a suitable guard to prevent heated particles from falling.

452.6 Storage and handling of raw material. Raw cellulose nitrate (pyroxylin) plastic material in a Group F building shall be stored and handled in accordance with Sections 452.6.1 through 452.6.7.

452.6.1 Storage of incoming material. Where raw material in excess of 25 pounds (11 kg) is received in a building or fire area, an approved vented cabinet or approved vented vault equipped with an approved automatic sprinkler system shall be provided for the storage of material.

452.6.2 Capacity limitations. Cabinets in any one workroom shall not contain more than 1,000 pounds (454 kg) of raw material. Each cabinet shall not contain more than 500 pounds (227 kg). Each compartment shall not contain more than 250 pounds (114 kg).

452.6.3 Storage of additional material. Raw material in excess of that allowed by Section 452.6.2 shall be kept in vented vaults not exceeding 1,500-cubic-foot capacity (43 m³) of total vault space, and with approved construction, venting and sprinkler protection.

452.6.4 Heat sources. Cellulose nitrate (pyroxylin) plastic shall not be stored within 2 feet (610 mm) of heat-producing appliances, steam pipes, radiators or chimneys.

452.6.5 Accumulation of material. In factories manufacturing articles of cellulose nitrate (pyroxylin) plastics, approved sprinklered and vented cabinets, vaults or storage rooms shall be provided to prevent the accumulation in workrooms of raw stock in process or finished articles.

452.6.6 Operators. In workrooms of cellulose nitrate (pyroxylin) plastic factories, operators shall not be stationed closer together than 3 feet (914 mm), and the amount of material per operator shall not exceed one shift's supply and shall be limited to the capacity of three tote boxes, including material awaiting removal or use.

452.6.7 Waste material. Waste cellulose nitrate (pyroxylin) plastic materials such as shavings, chips, turnings, sawdust, edgings and trimmings shall be kept under water in metal receptacles until removed from the premises.

452.7 Fire protection. The manufacture or storage of articles of cellulose nitrate (pyroxylin) plastic in quantities exceeding 100 pounds (45 kg) shall be located in a building or portion thereof equipped throughout with an approved automatic sprinkler system in accordance with Section 903.3.1.1.

452.8 Sources of ignition. Sources of ignition shall not be located in rooms in which cellulose nitrate (pyroxylin) plastic in excess of 25 pounds (11 kg) is handled or stored.

452.9 Heating. Rooms in which cellulose nitrate (pyroxylin) plastic is handled or stored shall be heated by low-pressure steam or hot water radiators.

Section 453 Unstable (Reactive) Materials**OSSC 453**

453.1 Scope. The storage and use of unstable (reactive) materials shall be in accordance with this section. *Compressed gases* shall also comply with Section 440.

Exceptions:

1. Display and storage in Group M and storage in Group S occupancies complying with Section 414.2.5.
2. Detonable unstable (reactive) materials shall be stored in accordance with Section 443.

453.2 Quantities not exceeding the maximum allowable quantity per control area. Quantities of unstable (reactive) materials not exceeding the *maximum allowable quantity per control area* shall be in accordance with Sections 453.2.1 through 453.2.2.5.

453.2.1 General. The storage and use of unstable (reactive) materials in amounts not exceeding the *maximum allowable quantity per control area* indicated in Section 415.1.5 shall be in accordance with Sections 414 and 453.

453.2.2 Limitations for indoor storage and use by occupancy. The indoor storage of unstable (reactive) materials shall be in accordance with Sections 453.2.2.1 through 453.2.2.5.

453.2.2.1 Group A, E, I or U occupancies. In Group A, E, I or U occupancies, any amount of Class 3 and 4 unstable (reactive) materials shall be stored in accordance with the following:

1. Class 3 and 4 unstable (reactive) materials shall be stored in *hazardous materials storage cabinets* complying with Section 414.14.
2. The *hazardous materials storage cabinets* shall not contain other storage.

453.2.2.2 Group R occupancies. Class 3 and 4 unstable (reactive) materials shall not be stored or used within Group R occupancies.

453.2.2.3 Group M occupancies. Class 4 unstable (reactive) materials shall not be stored or used in retail sales portions of Group M occupancies.

453.2.2.4 Offices. Class 3 and 4 unstable (reactive) materials shall not be stored or used in offices of Group B, F, M or S occupancies.

453.2.2.5 Classrooms. In classrooms in Group B, F or M occupancies, any amount of Class 3 and 4 unstable (reactive) materials shall be stored in accordance with the following:

1. Class 3 and 4 unstable (reactive) materials shall be stored in *hazardous materials storage cabinets* complying with Section 414.14.
2. The *hazardous materials storage cabinets* shall not contain other storage.

453.3 Quantities exceeding the maximum allowable quantity per control area. The storage and use of unstable (reactive) materials in amounts exceeding the *maximum allowable quantity per control area* indicated in Section 415.1.5 shall be in accordance with Sections 414 and 415 and this section.

453.4 Indoor storage. Indoor storage of unstable (reactive) materials in amounts exceeding the *maximum allowable quantity per control area* indicated in Table 307.1(1) shall be in accordance with Sections 414 and 415 and this section.

In addition, Class 3 and 4 unstable (reactive) detonable materials shall be stored in accordance with the requirements for *explosives* in this code.

453.4.1 Detached storage. Storage of unstable (reactive) materials shall be in detached buildings where required in Section 415.6.5.

453.4.2 Explosion control. Indoor storage rooms, areas and buildings containing Class 3 or 4 unstable (reactive) materials shall be provided with explosion control in accordance with Section 919.

453.4.3 Liquid-tight floor. In addition to Section 415.12.8, floors of storage areas for liquids and solids shall be of liquid-tight construction.

453.4.4 Storage configuration. Unstable (reactive) materials stored in quantities greater than 500 cubic feet (14 m³) shall be separated into piles, each not larger than 500 cubic feet (14 m³). Aisle width shall be not less than the height of the piles or 4 feet (1219 mm), whichever is greater.

Exception: Materials stored in tanks.

453.4.5 Location in building. Unstable (reactive) materials shall not be stored in *basements*.

Section 454 Water-Reactive Solids and Liquids**OSSC 454**

454.1 Scope. The storage and use of water-reactive solids and liquids shall be in accordance with this section.

Exceptions:

1. Display and storage in Group M occupancies and storage in Group S occupancies complying with Section 414.2.5.
2. Detonable water-reactive solids and liquids shall be stored in accordance with Section 443.

454.2 Quantities not exceeding the maximum allowable quantity per control area. The storage and use of water reactive solids and liquids in amounts not exceeding the *maximum allowable quantity per control area* indicated in Section 415.1.5 shall be in accordance with Sections 414 and 454.

454.3 Quantities exceeding the maximum allowable quantity per control area. The storage and use of water-reactive solids and liquids in amounts exceeding the *maximum allowable quantity per control area* indicated in Section 415.1.5 shall be in accordance with Sections 414 and 415 and this section.

454.4 Indoor storage. Indoor storage of water-reactive solids and liquids in amounts exceeding the *maximum allowable quantity per control area* indicated in Table 307.1(1) shall be in accordance with Sections 414 and 415 and this section.

454.4.1 Detached storage. Storage of water-reactive solids and liquids shall be in detached buildings where required by Section 415.6.5.

454.4.2 Liquid-tight floor. In addition to the provisions of Section 415.12.8, floors in storage areas for water-reactive solids and liquids shall be of liquid-tight construction.

454.4.3 Waterproof room. Rooms or areas used for the storage of water-reactive solids and liquids shall be constructed in a manner that resists the penetration of water through the use of waterproof materials. Piping carrying water for other than *approved automatic sprinkler systems* shall not be within such rooms or areas.

454.4.4 Watertight containers. Where Class 3 water-reactive solids and liquids are stored in areas equipped with an *automatic sprinkler system*, the materials shall be stored in closed, watertight *containers*.

454.4.5 Storage configuration. Water-reactive solids and liquids stored in quantities greater than 500 cubic feet (14 m³) shall be separated into piles, each not larger than 500 cubic feet (14 m³). Aisle widths between piles shall be not less than the height of the pile or 4 feet (1219 mm), whichever is greater.

Exception: Water-reactive solids and liquids stored in tanks:

Class 2 water-reactive solids and liquids shall not be stored in *basements* unless such materials are stored in closed, watertight *containers* or tanks.

Class 3 water-reactive solids and liquids shall not be stored in *basements*.

Class 2 or 3 water-reactive solids and liquids shall not be stored with flammable liquids.

454.4.6 Explosion control. Indoor storage rooms, areas and buildings containing Class 2 or 3 water-reactive solids and liquids shall be provided with explosion control in accordance with Section 919.

454.5 Use. The use of water-reactive solids and liquids in amounts exceeding the *maximum allowable quantity per control area* indicated in Table 414.2.5(1) shall be in accordance with Sections 414 and 415.

Section 455 Additive Manufacturing (3d Printing)

OSSC 455

455.1 Occupancies. Nonindustrial additive manufacturing shall be permitted in all occupancy groups.

455.2 Industrial additive manufacturing. Industrial additive manufacturing shall comply with Sections 455.2.1 through 455.2.9.

455.2.1 Combustible dusts and metals. Industrial additive manufacturing operations that store, use or produce combustible dust, combustible particulate solids or combustible metals shall comply with Section 426 and this section.

455.2.2 Powder evaluation. Printing powders used in industrial additive manufacturing operations shall be tested for combustibility in accordance with NFPA 484 or NFPA 652, as applicable. A copy of test reports shall be provided upon request.

455.2.3 Combustible (nonmetallic) dusts. Industrial additive manufacturing operations that store, use or produce combustible (nonmetallic) dusts shall comply with NFPA 654.

455.2.4 Combustible metals. Industrial additive manufacturing operations that store or use combustible metals shall comply with NFPA 484.

455.2.5 Hazardous materials. Industrial additive manufacturing operations that store or use hazardous materials exceeding the maximum allowable quantity limits shall comply with this code.

455.2.6 Inert gas. Additive manufacturing processes that utilize inert gases shall comply with this code. Ventilation or gas detection shall be provided in accordance with this code.

455.2.7 Technical assistance. Where required by the *building official*, an *approved* report evaluating the acceptability of technologies, processes, products, facilities, materials and uses associated with the operation shall be provided.

455.2.8 Performance-based design alternative. Where *approved*, buildings and facilities where industrial additive manufacturing is performed shall be permitted to comply with the performance-based design options in Section 414.1.4.3 as an alternative to compliance with the other requirements set forth in this section.

455.2.9 Occupancies. Industrial additive manufacturing shall be conducted only in the occupancy groups associated with manufacturing operation and permitted by the this code maximum allowable quantity tables. Where *approved*, the requirements in Section 455.2.4 shall be permitted to provide the technical basis for determining compliance with Table 307.1(1), **Note a**.

Section 456 Storage of Distilled Spirits and Wines**OSSC 456**

456.1 General. The storage of distilled spirits and wines in barrels and casks shall comply with this section in addition to the other applicable requirements of this code.

456.1.1 Nonapplicability. Sections 414 and 444 are not applicable to the storage of distilled spirits and wines in barrels and casks as identified in Section 444.1.1, Item 10.

456.2 Spill control. Drainage or containment systems shall be provided by means of curbs, scuppers, special drains or other suitable means to prevent the flow of spills throughout the building.

456.3 Ventilation. For rooms and spaces where distilled spirits and wines in barrels and casks are stored, ventilation shall be provided in accordance with the *Mechanical Code* and one of the following:

1. The rooms and spaces shall be ventilated at a rate sufficient to maintain the concentration of vapors within the area at or below 25 percent of the lower flammable limit (LFL). This shall be confirmed by sampling the actual vapor concentration under normal operating conditions. The sampling shall be conducted throughout the enclosed storage area, extending to or toward the bottom and the top of the enclosed storage area. The vapor concentration used to determine the required ventilation rate shall be the highest measured concentration during the sampling procedure. The sampling shall be conducted manually or by installation of a continuously monitoring flammable vapor detection system.
2. The rooms and spaces shall be provided exhaust ventilation at a rate of not less than 1 cfm per square foot [0.00508 m³/(s × m²)] of solid floor area. The exhaust ventilation shall be accomplished by natural or mechanical means, with discharge of the exhaust to a safe location outside the building.

456.4 Sources of ignition. Sources of ignition shall be controlled in accordance with Sections 456.4.1 through 456.5.

456.4.1 Smoking. Smoking shall be prohibited and “No Smoking” signs provided in rooms or areas where flammable or combustible hazardous materials are stored, dispensed or used.

Signs required by this section shall be in English as a primary language or in symbols allowed by this code.

456.4.2 Electrical. Electrical wiring and equipment shall be installed and maintained in accordance with the *Electrical Code*.

456.5 Lightning. Structures containing barrel storage should be protected from lightning. The lightning protection equipment shall be installed in accordance with the *Electrical Code* and NFPA 780.

456.6 Storage. Storage shall be in accordance with this section.

456.7 Basement storage. Class I liquids shall be allowed to be stored in basements in amounts not exceeding the maximum allowable quantity per control area for use-open systems in Table 307.1(1), provided that automatic suppression and other fire protection are provided in accordance with Chapter 9. Class II and IIIA liquids shall also be allowed to be stored in basements provided that automatic suppression and other fire protection are provided in accordance with Chapter 9.

456.8 Automatic sprinkler system. The storage of distilled spirits and wines shall be protected by an approved automatic sprinkler system as required by Chapter 9.

456.9 Hazard identification signs. Unless otherwise exempted, visible hazard identification signs, as specified in NFPA 704 for the for the specific material contained, shall be placed on stationary containers and above-ground tanks; at entrances to locations where hazardous materials are stored, dispensed, used or handled in quantities requiring a permit; and at specific entrances and locations designated by the *building official*.

456.9.1 Maintenance and style. Signs and markings required by Section 456.9 shall not be obscured; shall be in English as a primary language or in symbols allowed by this code; shall be durable; and the size, color and lettering shall be *approved*.

Section 457 Piers and Wharves

OSSC 457

See Section 101.2.1 for the scope of regulation for piers and wharves.

457.1 Scope. This section shall apply to regulated piers and wharves constructed, in whole or in part, of combustible materials and to regulated piers and wharves constructed of noncombustible materials having less than 2-hour fire-resistive protection of the structural elements or pier deck.

457.2 Fire-extinguishing systems. Automatic fire-extinguishing systems shall be installed as specified in Section 903.

457.3 Physical protection. Where sprinkler piping and fire-extinguishing equipment are subject to damage by floating debris, barriers shall be provided to exclude or protect against such debris. Protection from corrosion and freezing shall be provided where necessary.

457.4 Subdivision of substructures. All substructures of piers shall have the under-deck area subdivided by:

1. Transverse fire walls at intervals not exceeding 450 feet (137 169 mm) and a maximum area of 50,000 square feet (4625 m²) extending from the low water line to the deck. Where superstructures bridge a required fire wall, the fire wall shall

extend to the roof of the superstructure as required for fire walls in accordance with Chapter 7.

2. Transverse fire stops located between fire walls, spacing between fire walls, and fire stops shall not exceed 1550 feet (47 720 mm). Fire stops shall fit tightly against the pier deck and around any structural members of pipes that pass through the fire stop so that an effective barrier to fire and draft is maintained. Fire stops shall extend to the water line. Where aprons or platforms are built along the sides of a pier, fire stops shall extend to the outside edge of such aprons or platforms.

457.5 Detailed requirements. Fire walls shall be of reinforced concrete having a fire-resistance rating of 4 hours or other materials of equivalent stability and fire resistance. Fire stops shall be constructed of wood planking built up to a thickness of 4 inches (102 mm) and securely fastened to the structural frame or other construction having equivalent stability and fire resistance.

457.6 Superstructures. Except as provided in this section, superstructures located on piers and wharves shall be classified for occupancy and type of construction and constructed according to this code.

Section 458 Mausoleums and Columbariums

OSSC 458

458.1 Materials. Materials of construction of mausoleums and columbariums shall be as set forth in this code for Type I or II buildings without use of combustible materials.

Exception: Interior doors and frames and interior frames for glass screens may be constructed of wood.

458.1.1 Construction. All crypt walls and crypt floor slabs shall be constructed of poured-in-place reinforced concrete, without honeycombs.

Exception: Crypt opening slabs and the separation slabs between upper and lower spaces of a companion crypt may be installed after entombment and shall be of concrete or mineral-type material.

After entombment, the crypt opening shall be sealed in a manner to be odor tight. Crypt walls and floor slabs shall be not less than 3 inches (76 mm) thick.

458.1.2 Loading. Each crypt, including each crypt in companion crypts, shall be designed for a minimum total live load of 600 pounds (272 kg) for each individual human remains. No crypt shall contain more than four individual human remains.

458.1.3 Other methods and materials. Other methods and materials may be considered as set forth in Section 104.11, provided that they have similar qualities of permanence, odor tightness and fire resistance as those identified in this subsection.

458.1.4 Other occupancies. Areas used for assembly shall be classified and constructed as required in this code.

Exception: Occupancy separations are not required between mausoleums/columbariums and other occupancies.

458.1.5 Pressure relief. A pressure-relief passage shall be provided leading from each crypt to the roof above the structure. This pressure-balancing shaft shall be located near the rear of each crypt and shall be sealed until the time of entombment and then opened before the crypt is sealed. The rooftop opening shall not be located less than 10 feet (3048 mm) from any cemetery property line. This pressure-relief passage shall be continued to a gravel sump below the lowest crypt slab.

CHAPTER 5 GENERAL BUILDING HEIGHTS AND AREAS

Section 502 Building Address

IBC 502.1 **502.1 Address identification.** New and existing buildings shall be provided with *approved* address identification. The address identification shall be legible and placed in a position that is visible from the street or road fronting the property. Address identification characters shall contrast with their background. Address numbers shall be Arabic numbers or alphabetical letters. Numbers shall not be spelled out. Each character shall be a minimum of 4 inches (102 mm) high with a minimum stroke width of 1/2 inch (12.7 mm). ~~Where required by the fire code official, address identification shall be provided in additional approved locations to facilitate emergency response. Where access is by means of a private road and the building address cannot be viewed from the public way, a monument, pole or other approved sign or means shall be used to identify the structure. Address identification shall be maintained.~~

Section 503 General Building Height and Area Limitations

IBC 503.1.4 **503.1.4 Occupied roofs.** A roof level or portion thereof shall be permitted to be used as an occupied roof provided the occupancy of the roof is an occupancy that is permitted by Table 504.4 for the story immediately below the roof. The area of the occupied roofs shall not be included in the building area as regulated by Section 506. An occupied roof shall not be included in the *building height* or number of *stories* as regulated by Section 504, provided that the *penthouses* and other enclosed *rooftop structures* comply with Section 1511.

Exceptions: (*Exception 1 remains unchanged*)

2. Assembly occupancies shall be permitted on roofs of open parking garages of Type I or Type II construction, in accordance with the exception to Section 903.2.1.6.

Section 504 Building Height and Number of Stories

IBC Table 504.4

**TABLE 504.4
ALLOWABLE NUMBER OF STORIES ABOVE GRADE PLANE^{a, b}**

(All other parts of Table 504.4 remain unchanged)

OCCUPANCY CLASSIFICATION	TYPE OF CONSTRUCTION												
	See Footnotes	Type I		Type II		Type III		Type IV			Type V		
		A	B	A	B	A	B	A	B	C	HT	A	B
S-2, <u>S-3</u>	NS	UL	11	5	3	4	3	4	4	4	5	4	2
	S	UL	12	6	4	5	4	12	8	5	6	5	3

Section 506 Building Area

IBC Table 506.2

**TABLE 506.2
ALLOWABLE AREA FACTOR (A_r= NS, S1, S13R, S13D or SM, as applicable) IN SQUARE FEET^{a, b}**

(All other parts of Table 506.2 remain unchanged)

OCCUPANCY CLASSIFICATION	SEE FOOTNOTES	TYPE OF CONSTRUCTION											
		Type I		Type II		Type III		Type IV			Type V		
		A	B	A	B	A	B	A	B	C	HT	A	B
S-2, <u>S-3</u>	NS	UL	79,000	39,000	26,000	39,000	26,000	115,500	77,000	48,125	38,500	21,000	13,500
	S1	UL	316,000	156,000	104,000	156,000	104,000	462,000	308,000	192,500	154,000	84,000	54,000
	SM	UL	237,000	117,000	78,000	117,000	78,000	346,500	231,000	144,375	115,500	63,000	40,500

Section 508 Mixed Use and Occupancy

IBC 508.1 508.1 General. Each portion of a building shall be individually classified in accordance with Section 302.1. Where a building contains more than one occupancy group, the building or portion thereof shall comply with the applicable provisions of Section 508.2, 508.3, 508.4 or 508.5, or a combination of these sections.

Exceptions:

1. Occupancies separated in accordance with Section 510.
2. Where required by Table 415.6.5, areas of Group H-1, H-2 and H-3 occupancies shall be located in a *detached building* or structure.
3. Uses within live/work units, complying with Section 508.5, are not considered separate occupancies.
4. Uses within a winery are exempt from occupancy separation requirements where complying with one of the following:
 - 4.1. An automatic sprinkler system is provided throughout the fire area.
 - 4.2. Both a fire alarm system, with manual pull stations, and an automatic smoke detection system are installed throughout the building.

Incidental uses in accordance with Section 509, and storage rooms greater than 750 square feet (70 m²) in floor area where wine is stored in wood or cardboard cases, are not exempt from separation requirements.

IBC Table 508.4

**TABLE 508.4
REQUIRED SEPARATION OF OCCUPANCIES (HOURS)^f**

(All other parts of Table 508.4 remain unchanged)

OCCUPANCY	A, E		I-1 ^a , I-3, I-4		I-2		Ra		F-2, S-2 ^b , S-3, U		B ^o , F-1, M, S-1		H-1		H-2		H-3, H-4		H-5	
	S	NS	S	NS	S	NS	S	NS	S	NS	S	NS	S	NS	S	NS	S	NS	S	NS
F-2, S-2 ^b , S-3, U	N	1	1	2	2	NP	1c	2c	N	N	1	2	NP	NP	3	4	2	3	2	NP

OSSC 508.5.7.1 508.5.7.1 Detached dwellings or townhouses. Live/work units located within detached one-family and two-family dwellings or townhouses regulated by the Residential Code shall be provided with an automatic sprinkler system complying with Section 903.3.1.3.

CHAPTER 6

TYPES OF CONSTRUCTION

Section 601 General

IBC Table 601

TABLE 601
FIRE-RESISTANCE RATING REQUIREMENTS FOR BUILDING ELEMENTS (HOURS)

(All other parts of Table 601 remain unchanged)

BUILDING ELEMENT	TYPE I		TYPE II		TYPE III		TYPE IV				TYPE V	
	A	B	A	B	A	B	A	B	C	HT	A	B
Primary structural frame ^{fi} (see Section 202)	3 ^{a,b,h}	2 ^{a,b,c}	1 ^{b,c}	0 ^c	1 ^{b,c}	0	3 ^a	2 ^a	2 ^a	HT	1 ^{b,c}	0

For SI: 1 foot = 304.8 mm.

- Roof supports: Fire-resistance ratings of primary structural frame and bearing walls are permitted to be reduced by 1 hour where supporting a roof only. [This reduction is not applicable to occupied roofs or to roofs supporting rooftop structures regulated by Section 1511, vegetative roofs and landscaped roofs.](#)
- Except in Group F-1, H, M and S-1 occupancies, fire protection of structural members in roof construction shall not be required, including protection of primary structural frame members, roof framing and decking where every part of the roof construction is 20 feet or more above any floor immediately below. Fire-retardant-treated wood members shall be allowed to be used for such unprotected members.
- In all occupancies, heavy timber complying with Section 2304.11 shall be allowed for roof construction, including primary structural frame members, where a 1-hour or less fire-resistance rating is required.
- Not less than the fire-resistance rating required by other sections of this code.
- Not less than the fire-resistance rating based on fire separation distance (see Table 705.5).
- Not less than the fire-resistance rating as referenced in Section 704.10.
- Heavy timber bearing walls supporting more than two floors or more than a floor and a roof shall have a fire resistance rating of not less than 1 hour.
- [For the purpose of determining the fire-resistance rating of joints, penetrations, openings and ducts in concrete floor and roof two-way slabs having direct connections to the columns, the fire-resistance rating for associated secondary members shall be used.](#)
- [All reinforcing steel and post-tensioning tendons in concrete floor and roof two-way slabs having direct connections to the columns shall have concrete coverage adequate to provide the fire-resistance rating required for primary structural frame elements.](#)

Section 602 Construction Classification

IBC 602.4.2.2.2 602.4.2.2.2 Protected area. Interior faces of *mass timber* elements, including the inside face of exterior *mass timber walls* and *mass timber roofs*, shall be protected in accordance with Section 602.4.2.2.1.

Exceptions: Unprotected portions of mass timber ceilings and walls complying with Section 602.4.2.2.4 and the following:

- Unprotected portions of mass timber ceilings and walls complying with one of the following:
 - Unprotected portions of mass timber ceilings, including attached beams, shall be permitted and shall be limited to an area [less than or](#) equal to ~~20-100~~ percent of the floor area in any dwelling unit or fire area.
 - Unprotected portions of mass timber walls, including attached columns, shall be permitted and shall be limited to an area [less than or](#) equal to 40 percent of the floor area in any dwelling unit or fire area.

(Exceptions 1.3 and 2 remains unchanged)

IBC 602.4.2.2.4 602.4.2.2.4 Separation distance between unprotected mass timber elements. In each *dwelling unit* or *fire area*, unprotected portions of *mass timber walls* ~~and ceilings~~ shall be not less than 15 feet (4572 mm) from unprotected portions of other walls ~~and ceilings, measured horizontally along the ceiling and from other unprotected portions of walls~~ measured horizontally along the floor.

CHAPTER 7

FIRE AND SMOKE PROTECTION FEATURES

Section 705 Exterior Walls

IBC Table 705.5

TABLE 705.5
FIRE-RESISTANCE RATING REQUIREMENTS FOR EXTERIOR WALLS BASED ON FIRE SEPARATION DISTANCE^{a, d, g}

(All other parts of Table 705.5 remain unchanged)

FIRE SEPARATION DISTANCE = X (feet)	TYPE OF CONSTRUCTION	OCCUPANCY GROUP H ^e	OCCUPANCY GROUP F-1, M, S-1 ^f	OCCUPANCY GROUP A, B, E, F-2, I, R ⁱ , S-2, S-3, U ^h

IBC 705.8.6

705.8.6 Vertical exposure. Opening protectives of buildings shall comply with Sections 705.8.6.1 and 705.8.6.2.

705.8.6.1 Vertical exposure for buildings on the same lot. For buildings on the same lot, opening protectives having a *fire protection rating* of not less than $\frac{3}{4}$ hour shall be provided in every opening that is less than 15 feet (4572 mm) vertically above the roof of an adjacent building or structure ~~based on assuming an imaginary line between them~~. The opening protectives are required where the ~~fire separation distances from the imaginary line to each building or structure are~~ distance between the buildings or structures is less than 15 feet (4572 mm).

Exceptions:

1. Opening protectives are not required where the lower roof assembly of the adjacent building or structure has a *fire-resistance rating* of not less than 1 hour for a minimum distance of 10 feet (3048 mm) from the *exterior wall* facing the imaginary line and the entire length and span of the supporting elements for the fire-resistance-rated roof assembly has a *fire-resistance rating* of not less than 1 hour.
2. Buildings on the same lot and considered as portions of one building in accordance with Section 705.3 are not required to comply with Section 705.8.6.1.

705.8.6.2 Vertical exposure for buildings on separate lots. New buildings erected less than 15 feet (4572 mm) from existing buildings on separate lots shall comply with one of the following:

1. In addition to opening protectives required elsewhere in this code, where a new building is to be erected adjacent to an existing building, all opening protectives in the exterior wall of the new building are required to have a fire protection rating of not less than $\frac{3}{4}$ hour where these opening protectives are less than 15 feet (4572 mm) vertically above the roof of the existing building or structure. The opening protectives are required where the distance between the buildings or structures is less than 15 feet (4572 mm).
2. Where a new building is to be erected adjacent to an existing building and the roof of the new building is at a lower elevation than the existing building, the roof construction of the new building shall have a fire-resistance rating of not less than 1 hour for a minimum distance of 10 feet (3048 mm) from the exterior wall facing the existing building. The entire length and span of the supporting elements for the fire-resistance-rated roof assembly shall also have a fire-resistance rating of not less than 1 hour. The roof protections are required where the distance between the buildings or structures is less than 15 feet (4572 mm).

Section 706 Fire Walls

IBC 706.1.1 **706.1.1 Party walls.** Any wall located on a *lot line* between adjacent buildings, which is used or adapted for joint service between the two buildings, shall be constructed as a *fire wall* in accordance with Section 706. Party walls shall be constructed without openings and shall create separate buildings.

Exceptions:

- ~~1.~~ Openings in a party wall separating an *anchor building* and a mall shall be in accordance with Section 402.4.2.2.1.
- ~~2.~~ Party walls and fire walls are not required on lot lines dividing a building for ownership purposes where the aggregate height and area of the portions of the building located on both sides of the lot line do not exceed the maximum height and area requirements of this code. For the building official's review and approval, the official shall be provided with copies of dedicated access easements and contractual agreements that permit the owners of portions of the building located on either side of the lot line access to the other side for purposes of maintaining fire and life safety systems necessary for the operation of the building.

IBC 706.5 **706.5 Horizontal continuity.** Fire walls shall be continuous from exterior wall to exterior wall and shall extend not less than 18 inches (457 mm) beyond the exterior surface of exterior walls.

Exceptions: (*Exceptions 1 and 2 remain unchanged*)

3. Fire walls shall be permitted to terminate at the interior surface of noncombustible exterior sheathing where the building on each side of the fire wall is protected by an automatic sprinkler system installed in accordance with Section 903.3.1.1 or 903.3.1.2. The noncombustible exterior sheathing shall extend horizontally for a distance not less than the width of the fire wall at the termination.

Section 711 Floor and Roof Assemblies

IBC 711.2.4 **711.2.4 Fire-resistance rating.** The fire-resistance rating of horizontal assemblies shall comply with Sections 711.2.4.1 through 711.2.4.6 but shall be not less than that required by the building type of construction.

Exception: See Table 601, Notes h and i, for concrete floor and roof two-way slabs having direct connections to the columns.

CHAPTER 8

INTERIOR FINISHES

Section 802 General

IBC 802.4 **802.4 Applicability.** For buildings in flood hazard areas as established ~~in Section 1612.3 by~~ [the flood plain administrator](#), interior finishes, trim and decorative materials below the elevation required by Section 1612 shall be flood-damage-resistant materials.

Section 806 Decorative Materials and Trim

IBC 806.3 **806.3 Occupancy-based requirements.** *Not adopted*
IBC 806.4 through 806.9 *Renumbered accordingly*

OSSC 806.9 **806.9 Motion picture screens.** ~~The screens on which motion pictures are projected in Group A occupancies shall either meet the flame propagation performance criteria of Test Method 1 or 2, as appropriate, of NFPA 701 or comply with the requirements for a Class B interior finish in accordance with Section 803.~~

Section 808 Acoustical Ceiling Systems

IBC 808.1 **808.1 Acoustical ceiling systems.** The quality, design, fabrication and erection of metal suspension systems for acoustical tile and lay-in panel ceilings in buildings or structures shall conform to generally accepted engineering practice, the provisions of this chapter and other applicable requirements of this code.
[See Section 1613.1.1 for the design and construction of suspended acoustical tile and lay-in panel ceiling systems in structures assigned to Seismic Design Category C, D, E or F.](#)

CHAPTER 9

FIRE PROTECTION AND LIFE SAFETY SYSTEMS

Section 901 General

IBC 901.1 **901.1 Scope.** The provisions of this chapter shall specify where *fire protection* and *life safety systems* are required and shall apply to the design, installation, ~~and repair and operation of fire protection and life safety systems.~~ Fire department access, fire-fighting water supply and fire hydrants are not part of the *state building code*.

Provisions that specify maintenance requirements or testing intervals that occur after the issuance of the certificate of occupancy, required by Section 111, are not part of the *state building code* but are printed for the reader's convenience.

~~Fire protection and life safety systems shall be installed, repaired, operated and maintained in accordance with this code and the *International Fire Code*.~~ Any *fire protection or life safety system* for which an exception or reduction to the provisions of this code has been granted and approved shall be considered to be a required system.

Exception: Any *fire protection or life safety system* or portion thereof not required by this code shall be permitted to be installed for partial or complete protection provided that such system meets the requirements of ~~this code~~ the *state building code*.

901.1.1 Fire protection system shop drawings. Shop drawings, plans, specifications or sketches for a *fire protection system* shall be submitted to the *building official* pursuant to the requirements of the *state building code* and ORS Chapter 455 or ORS 479.155 to determine compliance with the *state building code*, including but not limited to fire and life safety standards, which are part of the *state building code*. Shop drawings, plans, specifications or sketches shall be *approved* prior to the start of system installation and shall contain all information as required by the referenced installation standards in Chapter 9.

IBC 901.2 **901.2 Fire protection systems.** *Fire protection or life safety systems* shall be installed and repaired in accordance with this code.

IBC 901.3 **901.3 Modifications.** Persons shall not remove, repair or modify any *fire protection system* installed or maintained under the provisions of this code ~~or the *International Fire Code*~~ without approval by the *building official*.

IBC 901.6 **901.6.1 Automatic sprinkler systems.** *Automatic sprinkler systems* shall be monitored by an *approved* supervising station.

Exceptions:

1. A supervising station is not required for *automatic sprinkler systems* installed in accordance with Section 903.3.1.3 ~~protecting one and two family dwellings.~~
2. Limited area systems in accordance with Section 903.3.8.

901.6.2 ~~901.6.3~~ **Fire alarm systems.** *Fire alarm systems* required by the provisions of Section 907.2 ~~of this code and Sections 907.2 and 907.9 of the *International Fire Code*~~ shall be monitored by an *approved* supervising station in accordance with Section 907.6.6 ~~of this code~~.

Exceptions: *(Exception 1 and 2 remain unchanged)*

3. Supervisory service is not required for *automatic sprinkler systems* installed in accordance with Section 903.3.1.3 ~~in one and two family dwellings.~~

901.6.3 ~~901.6.4~~ **Group H.** Supervision and monitoring of emergency alarm, detection and automatic fire-extinguishing systems in Group H occupancies shall be in accordance with this code ~~the *International Fire Code*.~~

901.7 901.6.2 Integrated testing. Where two or more *fire protection* or *life safety* systems are interconnected, the intended response of subordinate *fire protection* and *life safety* systems shall be verified when required testing of the initiating system is conducted. In addition, integrated testing shall be performed in accordance with Sections [901.7.1](#) and [901.7.2 901.6.2.1](#) and [901.6.2.2](#).

901.7.1 901.6.2.1 High-rise buildings. For high-rise buildings, integrated testing shall comply with NFPA 4, with an integrated test performed prior to issuance of the certificate of occupancy ~~and at intervals not exceeding 10 years, unless otherwise specified by an integrated system test plan prepared in accordance with NFPA 4~~. If an equipment failure is detected during integrated testing, a repeat of the integrated test shall not be required, except as necessary to verify operation of fire protection or life safety functions that are initiated by equipment that was repaired or replaced.

901.7.2 901.6.2.2 Smoke control systems. Where a *fire alarm system* is integrated with a smoke control system as outlined in Section 909, integrated testing shall comply with NFPA 4, with an integrated test performed prior to issuance of the certificate of occupancy ~~and at intervals not exceeding 10 years, unless otherwise specified by an integrated system test plan prepared in accordance with NFPA 4~~. If an equipment failure is detected during integrated testing, a repeat of the integrated test shall not required, except as necessary to verify operation of fire protection or life safety functions that are initiated by equipment that was repaired or replaced.

IBC 901.7 **901.8 901.7 Fire areas.** *Renumbered*

Section 902 Fire Pump and Riser Room Size

IBC 902.1.3 **902.1.3 Environment.** *Automatic sprinkler system* riser rooms and fire pump rooms shall be maintained at a temperature of not less than 40°F (4°C). Heating units shall be permanently installed. Pump and riser rooms heated solely for freeze protection shall be considered low-energy buildings and shall not be considered an unconditioned space, independent of the remainder of the building when applying the Energy Code.

Section 903 Automatic Sprinkler Systems

IBC 903.1.1 **903.1.1 Alternative protection.** Alternative *automatic fire-extinguishing systems* complying with Section 904 shall be permitted instead of *automatic sprinkler system* protection where recognized by the applicable standard and *approved by the fire code official*.

IBC 903.2.4.2 **903.2.4.2 Group F-1 distilled spirits.** An *automatic sprinkler system* shall be provided throughout a Group F-1 *fire area* used for the manufacture of distilled spirits or wine.

IBC 903.2.8.4 **903.2.8.4 Care facilities.** an *automatic sprinkler system* installed in accordance with Section 903.3.1.3 shall be permitted in care facilities ~~with five or fewer individuals~~ in a single-family dwelling.

IBC
Table 903.2.11.6

TABLE 903.2.11.6
ADDITIONAL REQUIRED PROTECTION SYSTEMS
(All other parts of Table 903.2.11.6 remain unchanged.)

SECTION	SUBJECT
IFC	Sprinkler system requirements as set forth in Section 903.2.11.6 of the International Fire Code

OSSC 903.2.11.7

903.2.11.7 Piers or wharves. An automatic sprinkler system shall be installed under regulated piers and wharves, which exceed 200 feet (60 960 mm) in length or 5,000 square feet (465 m²) in area. Such systems shall comply with NFPA 307, *Standard for the Construction and Fire Protection of Marine Terminals, Piers and Wharves*. See Section 101.2.1 for the scope of regulation for piers and wharves.

- IBC 903.2.12** **903.2.12 During construction.** *Not adopted*
- IBC 903.3.1.1.1** **903.3.1.1.1 Exempt locations.** Automatic sprinklers shall not be required in the following rooms or areas where such rooms or areas are protected with an *approved* automatic fire detection system in accordance with Section 907.2 that will respond to visible or invisible particles of combustion. Sprinklers shall not be omitted from a room merely because it is damp, of fire-resistance-rated construction or contains electrical equipment.
(Items 1, and 3-6 remains unchanged)
2. A room or space where sprinklers are considered undesirable because of the nature of the contents, where ~~approved~~ *approved by the fire code official.*
- IBC 903.3.1.2** **903.3.1.2 NFPA 13R sprinkler systems.** *Automatic sprinkler systems* in Group R occupancies shall be permitted to be installed throughout in accordance with NFPA 13R where the Group R occupancy meets all of the following conditions:
1. Four stories or fewer above *grade plane*.
 2. For other than Group R-2 occupancies, the floor level of the highest *story* is 30 feet (9144 mm) or less above the lowest level of required fire department vehicle access.
For Group R-2 occupancies, the roof assembly is less than 45 feet (13716 mm) above the lowest level of required fire department vehicle access. The height of the roof assembly shall be determined by measuring the distance from the lowest required fire vehicle access road surface adjacent to the building to the eave of the highest pitched roof, the intersection of the highest roof to the exterior wall, or the top of the highest parapet, whichever yields the greatest distance.
 3. The floor level of the lowest *story* is 30 feet (9144 mm) or less below the lowest level of required fire department vehicle access.
- The number of stories of Group R occupancies constructed in accordance with Sections 510.2 and 510.4 shall be measured from grade plane.
- IBC 903.3.1.2.1** **903.3.1.2.1 Balconies and decks.** Sprinkler protection shall be provided for exterior balconies, decks and ground floor patios of *dwelling units* and *sleeping units* where either of the following conditions exists:
1. The building is of Type V construction, ~~provided that there is a roof or deck above.~~
(Item 2 and the rest of Section 903.3.1.2.1 remains unchanged)
- IBC 903.3.1.2.3** **903.3.1.2.3 Attics.** *Attic* protection shall be provided as follows:
(Items 1 and 2, 3.1 through 3.4, and 4 remain unchanged)
3. Where located in a building of Type III, Type IV or Type V construction designed in accordance with Section 510.2 or 510.4, attics not required by Item 1 to have sprinklers shall comply with one of the following if the roof assembly is located more than 55 feet (16 764 mm) above the lowest level of required fire department vehicle access needed to meet the provisions in Section 503.
- The height of the roof assembly shall be determined by measuring the distance from the lowest required fire vehicle access road surface adjacent to the building to the eave of the highest pitched roof, the intersection of the highest roof to the exterior wall, or the top of the highest parapet, whichever yields the greatest distance. For the purpose of this measurement, required fire vehicle access roads shall include only those roads that are determined to be required by the fire official ~~necessary for compliance with Section 503 of the International Fire Code.~~
- IBC 903.3.5** **903.3.5 Water supplies.** Water supplies for *automatic sprinkler systems* shall comply with this section and the standards referenced in Section 903.3.1. The potable water supply shall be protected against backflow in accordance with the requirements of this section and the ~~International Plumbing Code~~. For connections to public waterworks systems, the water supply test used for design of *fire protection systems* shall be adjusted to account for seasonal and daily pressure fluctuations based on information from the water supply authority and ~~approved~~ *approved by the fire code official.*

IBC 903.4 **903.4 Sprinkler system supervision and alarms.** Valves controlling the water supply for *automatic sprinkler systems*, pumps, tanks, water levels and temperatures, critical air pressures and waterflow switches on all sprinkler systems shall be electrically supervised by a *listed fire alarm control unit*.

Exceptions:

1. *Automatic sprinkler systems* installed in accordance with Section 903.3.1.3 ~~protecting one and two family dwellings.~~

(Exceptions 2 through 8 remain unchanged)

903.4.1 Monitoring. Alarm, supervisory and trouble signals shall be distinctly different and shall be automatically transmitted to an *approved* supervising station or, where ~~approved by the fire code official~~, shall sound an audible signal at a *constantly attended location*.

(The exception remains unchanged)

IBC 903.5 **903.5 Testing ~~and maintenance~~.** *Automatic sprinkler systems* shall be tested ~~and maintained~~ in accordance with this code ~~the International Fire Code~~.

Section 904 Alternative Automatic Fire-Extinguishing Systems

IBC 904.2 **904.2 Where permitted.** Automatic fire-extinguishing systems installed as an alternative to the required *automatic sprinkler systems* of Section 903 shall be ~~approved by the fire code~~.

IBC 904.2.2 **904.2.2 Commercial hood and duct systems.** Each required commercial kitchen exhaust hood and duct system required by ~~the Section 606 of the International Fire Code or Chapter 5 of the International Mechanical Code~~ to have a Type I hood shall be protected with an approved automatic fire-extinguishing system installed in accordance with this code.

IBC 904.11.3 **904.11.3 Testing ~~and maintenance~~.** *Automatic water mist systems* shall be tested ~~and maintained~~ in accordance with this code ~~the International Fire Code~~.

IBC 904.12 **904.12 Aerosol fire-extinguishing systems.** Aerosol fire-extinguishing systems shall be installed, ~~maintained~~, periodically inspected and tested in accordance with NFPA 2010, and their listing.

Such devices and appurtenances shall be listed and installed in compliance with manufacturers' instructions.

IBC 904.14 **904.14 Domestic cooking facilities.** Cooktops and ranges installed in the following occupancies shall be protected in accordance with Section 904.14.1:

(Items 1 and 2 remain unchanged)

3. In Group R-2 college *dormitories* operated by a college or university for student housing where domestic cooking facilities are installed in accordance with Section 420.11.

Section 905 Standpipe Systems

IBC 905

Note: Consistent with the purpose and scope of application authorized in ORS 455.020, only the installation and construction standards for standpipe hose connections are adopted by the State of Oregon as part of the state building code. Standpipe hose connection locations shall be determined by the fire official.

- IBC 905.3.1** **905.3.1 Height.** Class III standpipe systems shall be installed throughout buildings where any of the following conditions exist:
1. Four or more stories are above or below *grade plane*.
 2. The floor level of the highest *story* is located more than 30 feet (9144 mm) above the lowest level of [required](#) fire department vehicle access.
 3. The floor level of the lowest *story* is located more than 30 feet (9144 mm) below the highest level of [required](#) fire department vehicle access.
- (The exceptions remain unchanged)*
- IBC 905.3.7** **905.3.7 Marinas and boatyards.** *Not adopted and IBC 905.3.8 is renumbered*
- IBC 905.5.3** **905.5.3 Class II system 1-inch hose.** A minimum 1inch (25 mm) hose shall be allowed to be used for hose stations in light-hazard occupancies where investigated and *listed* for this service and where *approved* ~~by the fire code official.~~
- IBC 905.11** **905.11 Locking standpipe outlet caps.** *Not adopted*

Section 906 Portable Fire Extinguishers

IBC 906

[The requirements of Section 906, Portable fire extinguishers, are not adopted by the State of Oregon as part of the state building code, consistent with the purpose and scope of application authorized in ORS 455.020. Local municipalities may not regulate these matters under the authority of this code.](#)

Section 907 Fire Alarm and Detection Systems

- IBC 907.1** **907.1 General.** This section covers the application, installation, performance and [repair](#) ~~maintenance~~ of fire alarm systems and their components.
- 907.1.1 Construction documents.** *Construction documents* for fire alarm systems shall be of sufficient clarity to indicate the location, nature and extent of the work proposed and show in detail that it will conform to the provisions of this code, ~~the International Fire Code;~~ and relevant laws, ordinances, rules and regulations, as determined by the ~~fire code official~~ [building official](#).
- IBC 907.2** **907.2 Where required—new buildings and structures.** An *approved fire alarm system* installed in accordance with the provisions of this code and NFPA 72 shall be provided in new buildings and structures in accordance with Sections 907.2.1 through 907.2.23 and provide occupant notification in accordance with Section 907.5, unless other requirements are provided by another section of this code.
- Not fewer than one manual fire alarm box shall be provided in an *approved* location to initiate a fire *alarm signal* for fire alarm systems employing automatic fire detectors or waterflow detection devices. Where other sections of this code allow elimination of fire alarm boxes due to sprinklers, a single fire alarm box shall be installed. [For Group R-2 occupancies, the manual fire alarm box shall not be located in an area that is open to the public.](#)
- Exceptions:**
- ~~1.—The manual fire alarm box is not required for fire alarm systems dedicated to elevator recall control and supervisory service.~~
 - ~~2.—The manual fire alarm box is not required for Group R-2 occupancies unless required by the fire code official to provide a means for fire watch personnel to initiate an alarm during a sprinkler system impairment event. Where provided, the manual fire alarm box shall not be located in an area that is open to the public.~~

- IBC 907.2.6** **907.2.6 Group I.** A manual *fire alarm system* that activates the occupant notification system in accordance with Section 907.5 shall be installed in Group I occupancies. An automatic smoke detection system that activates the occupant notification system in accordance with Section 907.5 shall be provided in accordance with Sections 907.2.6.1, 907.2.6.2 and 907.2.6.3.3.
- Exceptions:** (*Exception 1 remains unchanged*)
- Occupant notification systems are not required to be activated where private mode signaling installed in accordance with NFPA 72 is *approved* ~~by the fire code official and staff evacuation responsibilities are included in the fire safety and evacuation plan required by Section 404 of the International Fire Code.~~
- IBC 907.2.11** **907.2.11 Single- and multiple-station smoke alarms.** *Listed* single- and multiple-station smoke alarms complying with UL 217 shall be installed in accordance with Sections 907.2.11.1 through 907.2.11.7 and NFPA 72. In accordance with Section 907.5.2.1.3.2, Section 29.5.10 of NFPA 72 shall only apply to sleeping rooms of Group R-1 and R-2 occupancies required by Section 907.2.8 or 907.2.9 to have a fire alarm system.
- IBC 907.2.13.2** **907.2.13.2 Fire department communication system.** Where a wired communication system is permitted by the fire official and approved by the building official in lieu of an in-building two-way emergency responder communication coverage system in accordance with Section 918 ~~Section 510 of the International Fire Code~~, the wired fire department communication system shall be designed and installed in accordance with NFPA 72 and shall operate between a fire command center complying with Section 911, elevators, elevator lobbies, emergency and standby power rooms, fire pump rooms, *areas of refuge* and inside *interior exit stairways*. The fire department communication equipment device shall be provided at each floor level within the *interior exit stairway*. Approval of a wired communication system must be documented on OSSC Form 918 in accordance with Section 918.
- IBC 907.3.3** **907.3.3 Elevator emergency operation.** Automatic fire detectors installed for elevator emergency operation shall be installed in accordance with the provisions of the Elevator Code ASME A17.1/CSA B44 and NFPA 72.
- IBC 907.4.2.5** **907.4.2.5 Protective covers.** The ~~fire code official~~ building official is authorized to require the installation of *listed* manual fire alarm box protective covers to prevent malicious false alarms or to provide the manual fire alarm box with protection from physical damage. The protective cover shall be transparent or red in color with a transparent face to permit visibility of the manual fire alarm box. Each cover shall include proper operating instructions. A protective cover that emits a local *alarm signal* shall not be installed unless *approved*. Protective covers shall not project more than that permitted by Section 1003.3.3.
- IBC 907.5.2.2** **907.5.2.2 Emergency voice/alarm communication systems.** Emergency voice/alarm communication systems required by this code shall be designed and installed in accordance with NFPA 72. The operation of any automatic fire detector, sprinkler waterflow device or manual fire alarm box shall automatically sound an alert tone followed by voice instructions giving *approved* information and directions for a general or staged evacuation ~~in accordance with the building's fire safety and evacuation plans required by Section 404 of the International Fire Code~~. In high-rise buildings, the system shall operate on at least the alarming floor, the floor above and the floor below. Speakers shall be provided throughout the building by paging zones. At a minimum, paging zones shall be provided as follows: (*The rest of 907.5.2.2 remains unchanged*)
- IBC 907.5.2.3.2** **907.5.2.3.2 Groups I-1, ~~and R-1~~ and R-4.** *Habitable spaces* in *dwelling units* and *sleeping units* in Group I-1 and R-1 occupancies ~~in accordance with Table 907.5.2.3.2~~ shall be provided with visible alarm notification in accordance with Table 907.5.2.3.2 and the accessibility requirements of ICC A117.1. Visible alarms shall be activated by the in-room smoke alarm and the building *fire alarm system*, as applicable.

- IBC 907.5.2.3.3** **907.5.2.3.3 Group R-2.** In Group R-2 occupancies required by Section 907 to have a *fire alarm system*, visual alarms shall be provided within common and public areas, and are not required within individual dwelling units.
~~each story that contains dwelling units and sleeping units shall be provided with the capability to support future visible alarm notification appliances in accordance with Chapter 11 of ICC A117.1. Such capability shall accommodate wired or wireless equipment.~~
- 907.5.2.3.3.1 Wired equipment.** *Not adopted*
- IBC 907.6.6** **907.6.6 Monitoring.** Fire alarm systems required by this ~~code chapter or by the International Fire Code~~ shall be monitored by an *approved* supervising station in accordance with NFPA 72.
Exception: Monitoring by a supervising station is not required for:
(Exception 1 and 2 remain unchanged)
3. *Automatic sprinkler systems* installed in accordance with Section 903.3.1.3 ~~in one- and two-family dwellings.~~
- IBC 907.6.6.2** **907.6.6.2 MIY Monitoring.** Direct transmission of alarms associated with monitor it yourself (MIY) transmitters to a public safety answering point (PSAP) shall not be permitted unless approved ~~by the fire code official.~~
- IBC 907.6.6.3** **907.6.6.3 Termination of monitoring service.** *Not adopted*
- IBC 907.8** **907.8 Inspection, testing and maintenance.** *Not adopted*

Section 909 Smoke Control Systems

- IBC 909.5.2** **909.5.2 Testing of leakage area.** Compliance with the maximum total leakage area shall be determined by achieving the minimum air pressure difference across the barrier with the system in the smoke control mode for mechanical smoke control systems utilizing the pressurization method. Compliance with the maximum total leakage area of passive smoke control systems shall be verified through methods such as door fan testing or other methods, as approved ~~by the fire code official.~~
- IBC 909.7** **909.7 Airflow design method.** Where approved ~~by the fire code official~~, smoke migration through openings fixed in a permanently open position, which are located between smoke control zones by the use of the airflow method, shall be permitted. The design airflow shall be in accordance with this section. Airflow shall be directed to limit smoke migration from the fire zone. The geometry of openings shall be considered to prevent flow reversal from turbulent effects. Smoke control systems using the airflow method shall be designed in accordance with NFPA 92.
- IBC 909.8** **909.8 Exhaust method.** Where approved ~~by the fire code official~~ mechanical smoke control for large enclosed volumes, such as in *atriums* or malls, shall be permitted to utilize the exhaust method. Smoke control systems using the exhaust method shall be designed in accordance with NFPA 92.
- IBC 909.9** **909.9 Design fire.** The design fire shall be based on a rational analysis performed by the *registered design professional* and approved ~~by the fire code official~~. The design fire shall be based on the analysis in accordance with Section 909.4 and this section.
- IBC 909.10** **909.10 Equipment.** Equipment including, but not limited to, fans, ducts, automatic *dampers* and balance *dampers*, shall be suitable for its intended use, suitable for the probable exposure temperatures that the rational analysis indicates and as approved ~~by the fire code official~~.

- IBC 909.12.2** **909.12.2 Wiring.** Wiring shall be installed in accordance with *Electrical Code*. ~~In addition to meeting requirements of NFPA 70, all wiring, regardless of voltage, shall be fully enclosed within continuous raceways.~~
- IBC 909.15** **909.15 Control diagrams.** ~~Identical~~ Control diagrams showing all devices in the system and identifying their location and function shall be maintained current and kept on file with the fire code official, the fire department and in the fire command center in a format and manner approved by the fire code official.
- IBC 909.18.8.3.1** **909.18.8.3.1 Report filing.** A copy of the final report shall be ~~filed with the fire code official and an identical copy shall be~~ maintained in an *approved* location at the building.
- IBC 909.19** **909.19 System acceptance.** *Not adopted*
- 909.19 Reserved.**
- IBC 909.20.7.1** **909.20.7.1 Ventilation systems.** *Smokeproof enclosure* ventilation systems shall be independent of other building ventilation systems. The equipment, control wiring, power wiring and ductwork shall comply with one of the following: *(Items 1 through 3 remain unchanged)*
- Exception:**
- ~~1.~~ Control wiring and power wiring located outside of a 2-hour fire barrier construction shall be installed and protected in accordance with the *Electrical Code* and provide a fire resistance rating of not less than 2 hours, using any one of the following methods:
- ~~1.1. Cables used for survivability of required critical circuits shall be listed in accordance with UL 2196 and shall have a fire resistance rating of not less than 2 hours.~~
- ~~1.2. Where encased with not less than 2 inches (51 mm) of concrete.~~
- ~~1.3. Electrical circuit protective systems shall have a fire resistance rating of not less than 2 hours. Electrical circuit protective systems shall be installed in accordance with their listing requirements.~~
- IBC 909.21.7** **909.21.7 Testing.** Testing for performance shall be required in accordance with Section 909.18.8. ~~System acceptance shall be in accordance with Section 909.19.~~

Section 910 Smoke and Heat Removal

- IBC 910.5** **910.5 Maintenance.** *Not adopted*

Section 911 Fire Command Center

- IBC 911.1.1** **911.1.1 Location and access.** The location and access to the fire command center shall be approved by the ~~fire code~~ building official in consultation with the fire official.
- IBC 911.1.3** **911.1.3 Size.** The fire command center shall be not less than 0.015 percent of the total building area of the facility served or 200 square feet (19 m²) in area, whichever is greater, with a minimum dimension of 0.7 times the square root of the room area or 10 feet (3048 mm), whichever is greater. Where a fire command center is required for Group F-1 and S-1 occupancies with a building footprint greater than 500,000 square feet (46 452 m²) in area, the fire command center shall have a minimum size of 96 square feet (9 m²) with a minimum dimension of 8 feet (2348 mm) where approved by the fire code official.

Section 912 Fire Department Connections

IBC 912

Note: Consistent with the purpose and scope of application authorized in ORS 455.020, only the installation and construction standards for standpipe hose connections are adopted by the State of Oregon as part of the state building code. Standpipe hose connection locations shall be determined by the fire official.

IBC 912.2.2 912.2.2 Existing buildings. *Not adopted*

OSSC 912.4.4 **912.4.4 Vehicle impact protection.** ~~Vehicle impact protection required by this code shall be provided by posts that comply with Section 912.4.4.1 or by other approved physical barriers that comply with Section 912.4.4.2.~~

912.4.4.1 Posts. ~~Guard posts shall comply with all of the following requirements:~~

- ~~1. Constructed of steel not less than 4 inches (102 mm) in diameter and concrete filled.~~
- ~~2. Spaced not more than 4 feet (1219 mm) between posts on center.~~
- ~~3. Set not less than 3 feet (914 mm) deep in a concrete footing of not less than a 15-inch (381 mm) diameter.~~
- ~~4. Set with the top of the posts not less than 3 feet (914 mm) above ground.~~
- ~~5. Located not less than 3 feet (914 mm) from the protected object.~~

912.4.4.2 Other barriers. ~~Barriers, other than posts specified in Section 912.4.4.1, that are designed to resist, deflect or visually deter vehicular impact commensurate with an anticipated impact scenario shall be permitted where approved.~~

Section 913 Fire Pumps

IBC 913.1 913.1 General. Where provided, fire pumps for *fire protection systems* shall be installed in accordance with this section and NFPA 20.

Exception: ~~Pumps for automatic sprinkler systems installed in accordance with Section 903.3.1.3, or Section P2904 of the International Residential Code.~~

IBC 913.2.2 913.2.2 Circuits supplying fire pumps. Cables used for survivability of circuits supplying fire pumps shall be installed and protected in accordance with using one of the Electrical Code, Cables, or portions of cables, located within a fire pump room or generator room separated by fire-resistance-rated construction shall not require additional protection.
~~following methods:~~

- ~~1. Cables used for survivability of required critical circuits shall be listed in accordance with UL 2196 and shall have a fire resistance rating of not less than 1 hour.~~
- ~~2. Electrical circuit protective systems shall have a fire resistance rating of not less than 1 hour. Electrical circuit protective systems shall be installed in accordance with their listing requirements.~~
- ~~3. Construction having a fire resistance rating of not less than 1 hour.~~
- ~~4. The cable or raceway is encased in a minimum of 2 inches (51 mm) of concrete.~~

Exception: ~~This section shall not apply to cables, or portions of cables, located within a fire pump room or generator room which is separated from the remainder of the occupancy with fire-resistance-rated construction.~~

Section 915 Carbon Monoxide Detection

IBC 915.1

915.1 General. Carbon monoxide detection shall be installed in new buildings in accordance with Sections 915.1.1 through ~~915.5-915.6~~. Carbon monoxide detection shall be installed in existing buildings in accordance with Chapter ~~34-11 of the International Fire Code~~.

915.1.1 Where required.

915.1.1.1 Group R. Carbon monoxide detection shall be provided in Group R occupancies in the locations specified in Section 915.2.

915.1.1.2 Group I and E. Carbon monoxide detection shall be provided in Group I-1, I-2, and I-4 and R-occupancies and in classrooms in Group E occupancies in the locations specified in Section 915.2 where any of the conditions in Sections 915.1.2 through 915.1.6 exist.

915.1.2 Fuel-burning appliances and fuel-burning fireplaces. Carbon monoxide detection shall be provided in ~~dwelling units, sleeping units~~ and classrooms that contain a fuel-burning appliance or a fuel-burning fireplace.

915.1.3 Fuel burning, forced-air furnaces. Carbon monoxide detection shall be provided in ~~dwelling units~~, sleeping units and classrooms served by a fuel-burning, forced-air furnace.

Exception: Carbon monoxide detection shall not be required in ~~dwelling units, sleeping units~~ and classrooms if a carbon monoxide detector is provided in the first room or area served by each main duct leaving the furnace, and the carbon monoxide alarm signals are automatically transmitted to an approved location.

915.1.4 Fuel-burning appliances outside of ~~dwelling units, sleeping units and classrooms.~~ Carbon monoxide detection shall be provided in ~~dwelling units, sleeping units~~ and classrooms located in buildings that contain fuel-burning appliances or fuel-burning fireplaces.

Exceptions:

1. Carbon monoxide detection shall not be required in ~~dwelling units, sleeping units~~ and classrooms without communicating openings between the fuel-burning appliance or fuel-burning fireplace and the ~~dwelling unit, sleeping unit~~ or classroom.
2. Carbon monoxide detection shall not be required in ~~dwelling units, sleeping units~~ and classrooms where a carbon monoxide detector is provided in one of the following locations:
 - 2.1. In an *approved* location between the fuel-burning appliance or fuel-burning fireplace and the ~~dwelling unit, sleeping unit~~ or classroom.
 - 2.2. On the ceiling of the room containing the fuel-burning appliance or fuel-burning fireplace.

915.1.5 Private garages. Carbon monoxide detection shall be provided in ~~dwelling units, sleeping units~~ and classrooms in buildings with attached *private garages*.

Exceptions:

1. Carbon monoxide detection shall not be required in ~~dwelling units~~, sleeping units and classrooms without communicating openings between the *private garage* and the ~~dwelling unit, sleeping unit~~ or classroom.
2. Carbon monoxide detection shall not be required in ~~dwelling units, sleeping units~~ and classrooms located more than one *story* above or below a *private garage*.
3. Carbon monoxide detection shall not be required where the *private garage* connects to the building through an *open-ended corridor*.
4. Where a carbon monoxide detector is provided in an *approved* location between openings to a *private garage* and ~~dwelling units, sleeping units~~ or classrooms.

- IBC 915.2.1** **915.2.1 Dwelling units.** Carbon monoxide detection shall be installed in *dwelling units in each bedroom or within 15 feet (4572 mm) outside of each bedroom door* ~~outside of each separate sleeping area in the immediate vicinity of the bedrooms.~~ Where a fuel-burning appliance is located within a bedroom or its attached bathroom, carbon monoxide detection shall be installed within the bedroom.
- 915.2.2 Sleeping units.** Carbon monoxide detection shall be installed in *sleeping units*.
- Exception:** Carbon monoxide detection shall be allowed to be installed outside and within 15 feet (4572 mm) of each separate sleeping area ~~in the immediate vicinity of the sleeping unit~~ where the *sleeping unit* or its attached bathroom does not contain a fuel-burning appliance and is not served by a forced air furnace.
- OSSC 915.2.4** **915.2.4 Three or more dwellings.** In addition to the locations required by Sections 915.2.1, carbon monoxide detection shall be installed in any enclosed common areas within buildings containing three or more *dwelling units*.
- IBC 915.4.1** **915.4.1 Power source.** *Carbon monoxide alarms shall* ~~may be battery operated or may~~ receive their primary power from the building wiring system. Plug-in devices securely fastened to the structure and installed in accordance with the manufacturer's installation instructions are deemed to satisfy this requirement. Hardwired and plug-in carbon monoxide alarms shall be equipped with battery backup. ~~where such wiring is served from a commercial source, and when primary power is interrupted, shall receive power from a battery. Wiring shall be permanent and without a disconnecting switch other than that required for overcurrent protection.~~
- Exception:** ~~Where installed in buildings without commercial power, battery powered carbon monoxide alarms shall be an acceptable alternative.~~
- IBC 915.4.4** **915.4.4 Combination alarms.** Combination carbon monoxide/smoke alarms shall be an acceptable alternative to carbon monoxide alarms. Combination carbon monoxide/smoke alarms shall be listed in accordance with UL 217 and UL 2034. Smoke alarm features of combination smoke/carbon monoxide alarms shall be interconnected.
- IBC 915.6** **915.6 Maintenance.** *Not adopted*

Section 918 Emergency Responder Communication Coverage

IBC 918

918.1 General. Where required by this section, construction components of in-building two-way emergency responder communication coverage shall be provided in all new buildings ~~in accordance with Section 510 of the International Fire Code,~~ that meet one of the following criteria:

1. Any building with one or more basements or below-grade building levels.
2. Any underground building.
3. Any building more than five stories in height.
4. Any building 50,000 square feet (4645 m²) in size or larger.

For information about coverage requirements and acceptance testing regulated and enforced by the fire official, see Section 510 of the Oregon Fire Code.

918.1.1 Exceptions. A building meeting the criteria listed in Section 918.1 may be exempted from emergency responder communication coverage construction requirements for the following reasons:

1. Where permitted by the fire official and approved by the *building official*, a wired communication system in accordance with Section 907.2.13.2 shall be permitted to be installed or maintained in lieu of emergency responder communication coverage construction requirements.
2. Where recommended by the *fire official* and approved by the *building official*, construction requirements for an emergency responder communication coverage system are not necessary for the specific building based on the fire official's recommendation.

3. Any building listed in Section 918.1 that, through performance testing as approved by the fire official, meets the communication coverage requirements of Section 510 of the Oregon Fire Code.

918.1.2 Nonrequired systems. Any in-building two-way emergency responder communication coverage system or portion thereof not required by this code shall be permitted to be installed for partial or complete coverage provided that such system meets the requirements of the state building code.

918.2 Technical requirements. Equipment required to provide in-building two-way emergency responder communication coverage shall be listed in accordance with UL 2524.

918.3 Emergency Responder Communication Coverage Checklist (ERCC), OSSC Form 918. A completed Emergency Responder Communication Coverage Checklist, OSSC Form 918, shall be submitted to the building official at the time of initial permit application. OSSC Form 918 is available at Oregon.gov/bcd.

Exception: Where portions of the construction documents demonstrating compliance with Section 918 are being deferred in accordance with Section 107.3.4.1, only Parts I and II of OSSC Form 918 are required to be completed and submitted to the building official at the time of initial permit application.

918.4 Survivability. The following construction components shall be required as specified for the installation of emergency responder communication coverage systems:

1. The backbone, antenna distribution, radiating, or any fiber-optic cables shall be rated as plenum cables.
2. The backbone cables shall be connected to the antenna distribution, radiating, or copper cables using hybrid coupler devices of a value determined by the overall design.
3. Backbone cables shall comply with one of the following:
 - 3.1 Routed through an enclosure with a fire-resistance-rating of not less than 2 hours for buildings four stories or more, and not less than 1 hour for buildings less than four stories. Penetrations shall comply with Section 714. Openings shall be protected in accordance with Section 716, as required for shaft enclosures.
 - 3.2 Listed cables providing a fire-resistance-rating of not less than 2 hours for buildings four stories or more, and not less than 1 hour for buildings less than four stories.
 - 3.3 Provided with approved equivalent alternative protection.

4. The connection between the backbone cable and the antenna cables shall be made within an enclosure with a fire-resistance-rating of not less than 2 hours for buildings four stories or more, and not less than 1 hour for buildings less than four stories. Penetrations shall comply with Section 714. Openings shall be protected in accordance with Section 716, as required for shaft enclosures. Equivalent alternative protection of connections may be provided.

918.5 Signal booster requirements. If used, signal boosters shall meet the following requirements:

1. All signal booster components shall be contained in a National Electrical Manufacturer's Association (NEMA) 4-type waterproof cabinet.
2. Battery systems used for the emergency power source shall be contained in a NEMA 3R or higher-rated cabinet.
3. Equipment shall have FCC or other radio licensing authority certification and be suitable for public safety use prior to installation.
4. Where a donor antenna exists, isolation shall be maintained between the donor antenna and all inside antennas to not less than 20dB greater than the system gain under all operating conditions. Donor antennas shall be permanently affixed to the building unless otherwise approved.
5. Active RF-emitting devices used for in-building two-way emergency responder communication coverage systems shall have built-in oscillation detection and control circuitry.
6. The installation of amplification systems or systems that operate on or provide the means to cause interference on any in-building two-way emergency responder communication coverage network shall be coordinated and approved by the fire official.

918.6 System monitoring. The in-building two-way emergency responder communication coverage system shall be monitored by a listed fire alarm control unit, or where approved by the building official, shall sound an audible signal at a constantly attended on site location. Automatic supervisory signals shall include the following:

1. Loss of normal AC power supply.
2. System battery charger(s) failure.
3. Malfunction of the donor antenna(s).
4. Failure of active RF-emitting device(s).
5. Low-battery capacity at 70-percent reduction of operating capacity.
6. Failure of critical system components.
7. The communications link between the fire alarm system and the in-building two-way emergency responder communication coverage system.
8. Oscillation of active RF-emitting device(s).

918.7 Standby Power. Standby power for in-building two-way emergency responder communication coverage systems shall be in accordance with Chapter 27.

Section 919 Explosion Control

OSSC 919

919.1 General. Explosion control shall be provided in the following locations:

1. Where a structure, room or space is occupied for purposes involving explosion hazards as identified in Table 414.5.1.
2. Where quantities of hazardous materials specified in Table 414.5.1 exceed the maximum allowable quantities in Table 307.1(1).

Such areas shall be provided with explosion (*deflagration*) venting, explosion (*deflagration*) prevention systems or barricades in accordance with this section and NFPA 68, NFPA 69, or NFPA 495, as applicable. *Deflagration* venting shall not be utilized as a means to protect buildings from *detonation* hazards.

919.2 Required deflagration venting. Areas that are required to be provided with *deflagration* venting shall comply with the following:

1. Walls, ceilings and roofs exposing surrounding areas shall be designed to resist a minimum internal pressure of 100 pounds per square foot (psf) (4788 Pa). The minimum internal design pressure shall be not less than five times the maximum internal relief pressure specified in Item 5 of this section.
2. *Deflagration* venting shall be provided only in exterior walls and roofs.

Exception: Where sufficient exterior wall and roof venting cannot be provided because of inadequate exterior wall or roof area, *deflagration* venting shall be allowed by specially designed shafts vented to the exterior of the building.

3. *Deflagration* venting shall be designed to prevent unacceptable structural damage.

Where relieving a *deflagration*, vent closures shall not produce projectiles of sufficient velocity and mass to cause life-threatening injuries to the occupants or other persons on the property or adjacent public ways.

4. The aggregate clear area of vents and venting devices shall be governed by the pressure resistance of the construction assemblies specified in Item 1 of this section and the maximum internal pressure allowed by Item 5 of this section.
5. Vents shall be designed to withstand loads in accordance with this code.

Vents shall consist of any one or any combination of the following to relieve at a maximum internal pressure of 20 pounds per square foot (958 Pa), but not less than the loads required by this code:

- 5.1. Exterior walls designed to release outward.
- 5.2. Hatch covers.
- 5.3. Outward swinging doors.
- 5.4. Roofs designed to uplift.
- 5.5. Venting devices listed for the purpose.

6. Vents designed to release from the exterior walls or roofs of the building when venting a *deflagration* shall discharge directly to the exterior of the building where an unoccupied space not less than 50 feet (15 240 mm) in width is provided between the exterior walls of the building and the lot line.

Exception: Vents complying with Item 7 of this section.

7. Vents designed to remain attached to the building when venting a *deflagration* shall be so located that the discharge opening shall be not less than 10 feet (3048 mm) vertically from window openings and exits in the building and 20 feet (6096 mm) horizontally from exits in the building, from window openings and exits in adjacent buildings on the same lot, and from the lot line.
8. Discharge from vents shall not be into the interior of the building.

919.3 Explosion prevention systems. Explosion prevention systems shall be of an approved type and installed in accordance with the provisions of this code and NFPA 69.

919.4 Deflagration venting. Deflagration venting shall be of an approved type and installed in accordance with the provisions of this code and NFPA 68.

919.5 Barricades. Barricades shall be designed and installed in accordance with NFPA 495.

CHAPTER 10 MEANS OF EGRESS

Section 1002 Alterations

IBC 1002 1002.1 Alterations to existing means of egress. ~~1001.2 Minimum requirements.~~ It shall be unlawful to alter a building or structure in a manner that will reduce the number of *exits* or the minimum width or required capacity of the *means of egress* to less than required by this code. See Chapter 34.

~~[F] SECTION 1002 MAINTENANCE AND PLANS~~

Section 1006 Number of Exits and Exit Access Doorways

IBC 1006.2.2 **1006.2.2.1 Boiler, ~~i~~ncinerator and furnace rooms.** Two *exit access doorways* are required in ~~boiler,~~ incinerator and furnace rooms where the area is over 500 square feet (46 m²) and any fuel-fired equipment exceeds 400,000 British thermal units (Btu) (422 000 KJ) input capacity. Where two *exit access doorways* are required, one is permitted to be a fixed ladder or an *alternating tread device*. *Exit access doorways* shall be separated by a horizontal distance equal to one-half the length of the maximum overall diagonal dimension of the room.

1006.2.2.2 Equipment rooms containing boilers. Equipment rooms containing one or more boilers shall be provided with two *exit access doorways* where the room area is over 500 square feet (46 m²) and there are one or more boilers having a combined fuel capacity of 1,000,000 Btu/hr (293 kW) or more. Where two *exit access doorways* are required, one is permitted to be a fixed ladder or an *alternating tread device*. *Exit access doorways* shall be separated by a horizontal distance greater than or equal to one-half the length of the maximum overall diagonal dimension of the room.

(IBC 1006.2.2.2 is renumbered to 1006.2.2.3)
(IBC 1006.2.2.3 is renumbered to 1006.2.2.4)

1006.2.2.5 ~~1006.2.2.4~~ **Electrical rooms.** The location and number of *exit* or *exit access doorways* shall be provided for electrical rooms in accordance with ~~Section 110.26 of NFPA 70 for electrical equipment rated 1,000 volts or less, and Section 110.33 of the Electrical Code~~ NFPA 70 for electrical equipment rated over 1,000 volts. Panic hardware shall be provided where required in accordance with Section 1010.2.9.2.

(IBC 1006.2.2.5 is renumbered to 1006.2.2.6)
(IBC 1006.2.2.6 is renumbered to 1006.2.2.7)

Section 1010 Doors, Gates and Turnstiles

IBC 1010.2.9.2 **1010.2.9.2 Rooms with electrical equipment.** Exit or exit access doors serving transformer vaults, rooms designated for batteries or energy storage systems, or modular data centers shall be provided in accordance with the Electrical Code ~~be equipped with panic hardware or fire exit hardware.~~ Rooms containing electrical equipment rated 800 amperes or more that contain overcurrent devices, switching devices or control devices and where the exit or exit access door is less than 25 feet (7620 mm) from the equipment working space as required by the Electrical Code ~~NFPA 70~~, such doors shall not be provided with a latch or lock other than *panic hardware* or *fire exit hardware*. The doors shall swing in the direction of egress travel.

IBC 1010.2.14 **1010.2.14 Controlled egress doors in Groups I-1, ~~and I-2~~, R-3 and R-4 facilities providing care.** In facilities subject to licensure by the State of Oregon, electric locking systems, including electro-mechanical locking systems and electromagnetic locking systems, shall be permitted to be locked in the means of egress in Group I-1, ~~or I-2, R-3 or R-4 facilities providing care~~ ~~occupancies~~ where the clinical needs of persons receiving care require their containment. Controlled egress doors shall be permitted in such occupancies where the building is equipped throughout with an automatic sprinkler system in accordance with Section 903.3.1.1 in Groups I-1 and I-2, Section 903.3.1.3 in Group R-3 and Section 903.3.1.2 in group R-4 facilities providing care, or an approved automatic smoke detection system installed in accordance with Section 907, provided that the doors are installed and operate in accordance with all of the following:

(Items 1 through 3 and 6 through 8 remain unchanged)

4. A building occupant shall not be required to pass through more than two ~~one~~ doors equipped with a controlled egress locking system before entering an exit.
- ~~5. The procedures for unlocking the doors shall be described and approved as part of the emergency planning and preparedness required by Chapter 4 of the International Fire Code.~~

Exceptions: *(Exceptions 1 and 2 remain unchanged)*

3. In Group I-1, Condition 2; Group R-3; and Group R-4, Condition 2 facilities providing care, where an exterior refuge area is located within an enclosed yard, special egress locks located on doors or gates serving the refuge area need not automatically deactivate where the refuge area is located not less than 50 feet (15 240 mm) from the building and the doors or gates provide access to a public way. Each such refuge area shall provide not less than 15 square feet (1.39 m²) of net clear area for each occupant, unless the refuge area is located within the public way.

Section 1011 Stairways

IBC 1011.11 **1011.11 Handrails.** *Flights of stairways shall have handrails on each side and shall comply with Section 1014. Where glass is used to provide the handrail, the handrail shall comply with Section 2407.*

Exceptions: *(Exceptions 1 and 2 remain unchanged)*

3. In Group R-3 occupancies, decks, patios and walkways that have a change in elevation consisting of a flight of stairs with three or fewer risers, where the landing depth on each side of the change of elevation is greater than what is required for a landing, do not require handrails.
4. In Group R-3 occupancies, a change in elevation consisting of a ~~single riser~~ flight of stairs with three or fewer risers at an entrance or egress door does not require handrails.
5. Changes in room elevations consisting of a flight of stairs with three or fewer risers within dwelling units and sleeping units in Groups R-2 and R-3 do not require handrails.
6. Where a platform lift is in a stationary position and the floor of the platform lift serves as the upper landing of a stairway, handrails shall not be required on the stairway, provided that all of the following criteria are met:
 - 6.1. The stairway contains not more than two risers.
 - 6.2. A handhold, positioned horizontally or vertically, is located on one side of the stairway adjacent to the top landing.
 - 6.3. The handhold is located not less than 34 inches (864 mm) and not more than 42 inches (1067 mm) above the bottom landing of the stairway.
 - 6.4. The handhold gripping surface complies with Section 1014.3, and is not less than 4.5 inches (114 mm) in length.

IBC 1011.12 **1011.12 Stairway to roof.** In buildings four or more stories above *grade plane*, one *stairway* shall extend to the roof surface unless the roof has a slope steeper than four units vertical in 12 units horizontal (33-percent slope). Such *stairway* shall be marked at street and floor levels with a sign indicating that the *stairway* continues to the roof. Where roofs are used as vegetative roofs or for other purposes, *stairways* shall be provided as required for such occupancy classification.

Exception: Other than where required by Section 1011.12.1, in buildings without an occupied roof access to the roof from the top story shall be permitted to be by an *alternating tread device*, or a ship's ladder ~~or a permanent ladder~~. The *alternating tread device* or *ship's ladder* shall be constructed of noncombustible material, and not less than 30 inches (762 mm) in clear width at or below the required handrails. *Alternating tread devices* shall otherwise comply with Section 1011.14 and *ship's ladders* shall otherwise comply with Section 1011.15.

IBC 1011.12.2 **1011.12.2 Roof access.** Where a stairway is provided to a roof, access to the roof shall be provided through a penthouse complying with Section 1511.2.

Exception: In buildings without an occupied roof, access to the roof shall be permitted to be a roof hatch or trap door. In buildings four or more stories above grade plane, the roof hatch or trap door shall be not less than 16 square feet (1.5 m²) in area and having a minimum dimension of 2 feet (610 mm) 36 inches (914 mm) in width and 8 feet (2438 mm) in length.

Section 1015 Guards

IBC 1015.2 **1015.2 Where required.** *Guards* shall be located along open-sided walking surfaces, including *mezzanines, equipment platforms, aisles, stairs, ramps* and landings that are located more than 30 inches (762 mm) measured vertically to the floor or grade below at any point within 36 inches (914 mm) horizontally to the edge of the open side. *Guards shall be provided at the perimeter of the occupied portions of an occupied roof.* *Guards* shall be adequate in strength and attachment in accordance with Section 1607.9. *(Exceptions remain unchanged)*

IBC 1015.8 **1015.8 Window openings.** Windows in Group R-2 and R-3 buildings including *dwelling units*, where the bottom of the clear opening of an operable window is located less than 36 inches (914 mm) above the finished floor and more than 72 inches (1829 mm) above the finished grade or flat surface not less than 36 inches (914 mm) in width ~~other surface~~ below on the exterior of the building, shall comply with one of the following: *(Items 1 through 4 remain unchanged)*

Section 1017 Exit Access Travel Distance

IBC 1017.8

**TABLE 1017.2
EXIT ACCESS TRAVEL DISTANCE^a**

(All other parts of Table 1017.2 remain unchanged)

- a. See the following sections for modifications to exit access travel distance requirements:
- Section 402.8: For the distance limitation in malls. Section 407.4: For the distance limitation in Group I-2.
 - Sections 408.6.1 and 408.8.1: For the distance limitations in Group I-3.
 - Section 411.2: For the distance limitation in special amusement areas.
 - Section 412.6: For the distance limitations in aircraft manufacturing facilities.
 - Section ~~1006.2.2.3~~ ~~1006.2.2.2~~: For the distance limitation in refrigeration machinery rooms.
 - Section ~~1006.2.2.4~~ ~~1006.2.2.3~~: For the distance limitation in refrigerated rooms and spaces.
 - Section 1006.3.4: For buildings with one exit.
 - Section 1017.2.2: For increased distance limitation in Groups F-1 and S-1.
 - Section 1017.2.3: For increased distance limitation in Group H-5.
 - Section 1030.7: For increased limitation in assembly seating.
 - Section 3103.4: For temporary structures.
 - Section 3104.9: For pedestrian walkways.

- OSSC 1017.2.3** **1017.2.3 Group H-5 increase.** The maximum *exit access* travel distance shall be 300 feet (91 m) in the fabrication areas of Group H-5 occupancies where all of the following conditions are met:
1. The width of the fabrication area is not less than 300 feet (91 m).
 2. The area of the fabrication area is not less than 220,000 square feet (18 600 m²).
 3. The height of the fabrication area measured between the raised metal floor and the clean filter ceiling is not less than 16 feet (4877 mm).
 4. The supply ventilation rate is not less than 20 cfm per square foot, not less than 25 percent fan filter unit (FFU) coverage and is running at full capacity during egress.

Section 1031 Emergency Escape and Rescue

- OSSC 1031.7** **1031.7 Emergency escape and rescue openings under decks, porches and similar projections.** *Emergency escape and rescue openings* shall be permitted to be installed under decks, porches and similar projections, provided that the location of the projection allows the *emergency escape and rescue openings* to be fully opened and provides a path not less than 36 inches (914 mm) in height to a *yard* or court.
- OSSC 1031.8** **1031.8 Emergency escape and rescue openings above lower roof surfaces.** *Emergency escape and rescue openings* located above a portion of roof surface below shall be provided with an unobstructed path, not less than 36 inches (914 mm) in width, from the vertical plane of the opening to the nearest edge of the lower roof, as practicable.

CHAPTER 11

ACCESSIBILITY

Section 1102 Compliance

IBC 1102.1 **1102.1 Design.** Buildings and facilities shall be designed and constructed to be *accessible* in accordance with this code and ICC A117.1, [as detailed in this chapter](#).

1102.1.1 Alternate methods. [The application of Section 104.10 to this chapter shall be limited to the extent that alternate methods of construction, designs or technologies provide substantially equivalent or greater accessibility. Where *approved* by the *building official*, the provisions of the Fair Housing Act Amendments of 1988 may be considered as an alternate method to the criteria outlined in ICC A117.1 as it relates to *covered-multifamily dwellings*.](#)

[ORS 447.220](#) is not a part of this code but is reprinted here for the reader's convenience:

447.220 Purpose. [It is the purpose of ORS 447.210 to 447.280 to make affected buildings, including but not limited to commercial facilities, public accommodations, private entities, private membership clubs and churches, in the state accessible to and usable by persons with disabilities, as provided in the Americans with Disabilities Act, and to make covered multifamily dwellings in the state accessible to and usable by all persons with disabilities, as provided in the Fair Housing Act. In requiring that buildings and facilities be usable by persons with disabilities, it is not the intention of the Legislative Assembly to require that items of personal convenience such as rest rooms, telephones and drinking fountains be provided for members of the public who have disabilities if they are not otherwise provided for members of the public who do not have disabilities. However, pursuant to the Americans with Disabilities Act, the Director of the Department of Consumer and Business Services may provide greater protection to individuals with disabilities by adopting more stringent standards than prescribed by the Americans with Disabilities Act.](#)

1102.1.2 Amendments to ICC A117.1. [The provisions of this section shall be considered amendments to ICC A117.1.](#)

1102.1.2.1 Elevators—ICC A117.1, Section 407. [ICC A117.1, Section 407 is not adopted. Elevators are expressly regulated through the *Elevator Code*.](#)

1102.1.2.2 Limited-use/limited-application elevators (LULA)—ICC A117.1, Section 408. [ICC A117.1, Section 408 is not adopted. LULAs are expressly regulated through the *Elevator Code*.](#)

1102.1.2.3 Private residence elevators—ICC A117.1, Section 409. [ICC A117.1, Section 409 is not adopted. Private residence elevators are expressly regulated through the *Elevator Code*.](#)

1102.1.2.4 Platform lifts—ICC A117.1, Section 410. [ICC A117.1, Section 410 is not adopted. Platform lifts are expressly regulated through the *Elevator Code*.](#)

1102.1.2.5 Door opening force—ICC A117.1, Section 404.2.8. [ICC A117.1, Section 404.2.8 is deleted in its entirety and replaced with the following: The opening force of doors along an *accessible route* shall be as follows:](#)

- [1. Exterior doors: 8¹/₂ pounds-maximum \(lbf\) \(37.8 N\).](#)
- [2. Interior doors: 5 pounds-maximum \(lbf\) \(22.2 N\).](#)

3. Stairway doors at pressurized stair enclosures: 15 pounds maximum (6.8 kg) at exterior doors.

4. Where environmental conditions require greater closing pressure, power-operated doors shall be used within the *accessible route*.

Exception: The force required to retract latch bolts or disengage other devices that hold the door or gate in a closed position shall not apply to panic hardware, delayed egress devices or fire-rated hardware.

1102.1.2.6 Detectable warnings—ICC A117.1, Section 406.6. ICC A117.1, Section 406.6 is deleted in its entirety.

1102.1.2.7 Parking spaces – ICC A117.1 Section 502. ICC A117.1 Sections 502.5, 502.6, 502.10 and 502.11 are adopted. The remaining provisions of ICC A117.1 Section 502 are deleted. *Accessible parking spaces, dimensions, markings and signs shall be designed in compliance with the Standards for Accessible Parking Places set forth by the Oregon Transportation Commission. See ORS 447.233.*

1102.1.2.8 Recreational facilities—ICC A117.1, Chapter 10. ICC A117.1, Chapter 10 is adopted as follows:

1. Section 1001.2.1 General exceptions. Section 1001.2.1 is adopted in its entirety.
2. Section 1001.2.2 Area of sport activity. Section 1001.2.2 is adopted but is restricted in application to sites where buildings and facilities meeting the definition of “*Affected buildings*” are constructed. See ORS 447.210(1).
3. Section 1001.3 Protruding objects. Section 1001.3 is adopted in its entirety.
4. Section 1001.4 Animal containment. Section 1001.4 is adopted but is restricted in application to sites where buildings and facilities meeting the definition of “*Affected buildings*” are constructed. See ORS 447.210(1).
5. Section 1002 Amusement rides. Section 1002 is not adopted. Amusement rides are regulated exclusively through the *Oregon Amusement Ride and Device Specialty Code*.
6. Section 1003 Recreational boating facilities. Section 1003 is not adopted.
7. Section 1004 Exercise machines and equipment. Section 1004 is not adopted.
8. Section 1005 Fishing piers and platforms. Section 1005 is not adopted.
9. Section 1006 Golf facilities. Section 1006 is not adopted.
10. Section 1007 Miniature golf facilities. Section 1007 is adopted but is restricted in application to sites where buildings and facilities meeting the definition of “*Affected buildings*” are constructed. See ORS 447.210(1).
11. Section 1008 Play areas. Section 1008 is adopted but is restricted in application to play structures as governed by Section 424.
12. Section 1009 Swimming pools, wading pools, hot tubs and spas. Section 1009 is not adopted.
13. Section 1010 Shooting ranges. Section 1010 is adopted but is restricted in application to sites where buildings and facilities meeting the definition of “*Affected buildings*” are constructed. See ORS 447.210(1).

1102.1.2.9 Type A unit operable parts – ICC A117.1 Section 1103.9. ICC A117.1, Section 1103.9 is revised by adding the following exception:

Exception: In a kitchen, receptacle outlets are permitted to be located over countertops 25¹/₂ inches maximum in depth, provided that there is at least one countertop with an accessible outlet compliant with this section.

1102.1.2.10 Type B unit operable parts – ICC A117.1 Section 1104.9. ICC A117.1, Section 1103.9 is replaced with the following:

Lighting controls, electrical switches and receptacle outlets, environmental controls, electrical panelboards, and user controls for security or intercom systems shall comply with Sections 309.3 and 1104.1.1.

Exceptions:

1. Receptacle outlets serving a dedicated use.
2. In a kitchen where two or more receptacle outlets are provided above a length of countertop that is uninterrupted by a sink or appliance, only one receptacle outlet shall be required to comply with this section.
3. In a kitchen where a clear floor space for a parallel approach cannot be located at a countertop in a corner between appliances, receptacle outlets over the countertop shall not be required to comply with this section, provided that the countertop area does not exceed 9 square feet (0.835 m²) maximum and there is at least one other countertop with an accessible outlet compliant with this section.
4. In a kitchen where a clear floor space for a parallel approach cannot be located at a countertop between range and refrigerator, receptacle outlets over the countertop shall not be required to comply with this section, provided that the countertop area does not exceed 18 inches (460 mm) in width and there is at least one other countertop with an accessible outlet compliant with this section.
5. Floor receptacle outlets.
6. HVAC diffusers.
7. Controls mounted on ceiling fans.
8. Controls or switches mounted on appliances.
9. Plumbing fixture controls.
10. Reset buttons and shut-offs serving appliances, piping and plumbing fixtures.
11. Where redundant controls other than light switches are provided for a single element, one control in each space shall not be required to comply with this section.
12. Within kitchens and bathrooms, lighting controls, electrical switches and receptacle outlets are permitted to be located over cabinets with countertops 36 inches (915 mm) maximum in height and 25^{1/2} inches (650 mm) maximum in depth.

Section 1103 Scoping Requirements

OSSC 1103.2.15 1103.2.15 Private membership clubs and churches. In accordance with ORS 447.210(1), private membership clubs and churches that have more than one floor level and more than 4,000 square feet (372 m²) in ground area or more than one floor level and more than 20 feet (6096 mm) in height, measured from the top surface of the lowest flooring to the highest interior overhead finish of the building, are required to be accessible.

Section 1104 Accessible Route

IBC 1104.4 **1104.4 Multistory buildings and facilities.** At least one *accessible route* shall connect each accessible *story*, *mezzanine* and occupied roofs in multilevel buildings and *facilities*.

Exceptions: (*Exceptions 1-4 remain unchanged*)

5. In private buildings or facilities that are less than three stories and that have less than 3,000 square feet (279 m²) per story, an accessible route shall not be required to connect stories provided that the building or facility is not a shopping center; shopping mall; professional office of a health care provider; or terminal, depot or other station used for specified public transportation or airport passenger terminal.

6. In a parking garage of fewer than three stories, an *accessible route* need not be provided to an upper or lower floor level provided that all of the *accessible parking spaces* are provided on a floor level with an *accessible route* to an *accessible building entrance* or to another building.
7. In a building of fewer than three *stories*, an *accessible route* need not be provided in the portion of the building that is one of the following occupancy classifications:
 - 7.1. Groups F-1 and F-2.
 - 7.2. Groups H-1, H-2, H-3, H-4 and H-5.
 - 7.3. Group S-1 and 2.
 - 7.4. Group U.
8. In a building of fewer than three *stories* that contains a Group B or M occupancy mixed with a Group F-1 or F-2; Group H-2, H-3, H-4 or H-5; Group S-1 or S-2; or Group U occupancy, an *accessible route* need not be provided if the Group B or M occupancy is less than 3,000 square feet (279 m²) on any floor level without an *accessible route*.
9. In a building of fewer than two *stories*, an elevator need not be provided to a *mezzanine* that is less than 3,000 square feet (279 m²).
10. In a building of fewer than three stories, an *accessible route* need not be provided where ramps, grade-level entries or *accessible horizontal connections* from adjacent buildings are provided to each floor level, provided all facilities, elements and spaces are connected to an *accessible route*.

OSSC 1104.5

1104.5 Elevators required. Elevators shall be provided in all shopping centers; shopping malls; professional offices of health care providers; terminals, depots or other stations used for specified public transportation; airport passenger terminals; and government buildings that are covered by Title II of the *Americans with Disabilities Act*.

Exceptions:

1. Elevators need not be provided in buildings and spaces listed in ORS 447.247(1)(a), which are exempt from the *accessible route* provisions in accordance with Section 1104.4, Exception 4.
2. Elevators need not be provided in buildings and spaces listed in ORS 447.247(1)(b), which are exempt from the *accessible route* provisions of Section 1104.4.
3. Elevators are not required where a terminal, depot or other station used for specified public transportation or airport passenger terminals are provided with an *accessible route* to all portions of the facilities.

ORS 447.247 is not a part of this code but is reprinted here for the reader's convenience:

447.247 Elevators required; criteria; rules.

(1) Elevators are required:

(a) In all shopping centers, shopping malls, professional offices of health care providers and government buildings that are covered by Title II of the *Americans with Disabilities Act*.

(b) In all other commercial facilities, private entities and places of public accommodation covered by Title III of the *Americans with Disabilities Act* that have more than one floor level and more than 3,000 square feet in ground area or that are more than 20 feet in height, measured from the top surface of the lowest flooring to the highest interior overhead finish of the building; and

(c) In all private membership clubs and churches that have more than one floor level and more than 4,000 square feet in ground area or that are more than 20 feet in height, measured from the top surface of the lowest flooring to the highest interior overhead finish of the building.

(2) The Department of Consumer and Business Services may by rule create exceptions to the requirements of this section if this section would require an elevator in a building that would not be required to have an elevator under the provisions of the *Americans with Disabilities Act* or the *Fair Housing Act*.

(1104.5 and 1104.6 are renumbered accordingly)

Section 1106 Parking And Passenger Loading Facilities

IBC 1106.1 **1106.1 General.** Parking shall comply with [ORS 447.233](#) and Sections 1106.2 through [1106.9](#) ~~1106.8~~. Passenger loading zones shall comply with Section [1106.8](#) ~~1106.9~~.

[ORS 447.233\(5\) through \(7\)](#) are not a part of this code but are reprinted here for the reader's convenience:

[447.233 Accessible parking space requirements; inspection of spaces; violation.](#)

(5) The director is authorized to inspect parking spaces and facilities and buildings subject to the provisions of this section, and to do whatever is necessary to enforce the requirements, including the maintenance requirements, of this section. Municipalities and counties may administer and enforce the requirements of this section in the manner provided under ORS 455.148 or 455.150 for administration and enforcement of specialty codes. All plans for parking spaces subject to the provisions of this section must be approved by the director prior to the creation of the spaces.

(6) Requirements adopted under this section do not apply to longterm parking facilities at the Portland International Airport.

(7) Any reported violation of this section shall be investigated by the administrative authority. The administrative authority shall make a final decision and order correction, if necessary, within 30 days of notification. Any aggrieved person may appeal within 30 days of the decision by the administrative authority to the appropriate municipal appeals board or, at the option of the local jurisdiction, directly to the Building Codes Structures Board established under ORS 455.132. The appeal shall be acted upon within 60 days of filing. The decision of the municipal appeals board may be appealed to the board. The board shall act on the appeal within 60 days of filing. All appeals to the board shall be filed in accordance with ORS 455.690.

IBC 1106.6 **1106.6 Van spaces.** For every six or fraction of six accessible parking spaces, at least one shall be a van-accessible parking space. [Where five or more parking spaces are designated accessible, any space that is designated as van accessible shall be reserved for wheelchair users.](#) *(The exception remains unchanged)*

**TABLE 1106.2
ACCESSIBLE PARKING SPACES**

TOTAL PARKING SPACES PROVIDED IN PARKING FACILITIES	REQUIRED MINIMUM NUMBER OF ACCESSIBLE SPACES	NUMBER OF VAN ACCESSIBLE SPACES	"WHEELCHAIR USER ONLY" SPACES
1 to 25	1	<u>1</u>	<u>=</u>
26 to 50	2	<u>1</u>	<u>=</u>
51 to 75	3	<u>1</u>	<u>=</u>
76 to 100	4	<u>1</u>	<u>=</u>
101 to 150	5	<u>=</u>	<u>1</u>
151 to 200	6	<u>=</u>	<u>1</u>
201 to 300	7	<u>=</u>	<u>2</u>
301 to 400	8	<u>=</u>	<u>2</u>
401 to 500	9	<u>=</u>	<u>2</u>
501 to 1,000	2% of total	<u>=</u>	<u>1 in every 6 accessible spaces or portion thereof</u>
1,001 and over	20, plus one for each 100, or fraction thereof, over 1,000	<u>=</u>	<u>1 in every 6 accessible spaces or portion thereof</u>

IBC 1106.7 **1106.7 Location.** Accessible parking spaces shall be located on the shortest [practical accessible route](#) of travel from adjacent parking to an accessible building entrance. In parking facilities that do not serve a particular building, accessible parking spaces shall be located on the shortest route to an accessible pedestrian entrance to the parking facility. Where buildings have multiple accessible entrances with adjacent parking, [accessible](#) parking spaces shall be dispersed and located near the accessible entrances. *(The exceptions remain unchanged)*

OSSC 1106.8

1106.8 Surfaces and identification of parking spaces.

1106.8.1 General. *Accessible* car and van parking spaces shall comply with the surface requirements of ICC ANSI A117.1, Section 502.5. *Accessible* parking spaces, dimensions, markings and signs shall be designed in compliance with the *Standards for Accessible Parking Places* set forth by the Oregon Transportation Commission.

1106.8.2 Identification. Identification of *accessible* parking spaces shall be in accordance with the *Standards for Accessible Parking Places* set forth by the Oregon Transportation Commission.

IBC 1106.8

1106.9 ~~1106.8~~ Parking meters and pay stations. Where parking meters and pay stations serve accessible parking spaces on an affected building site, such parking meters and pay stations shall be *accessible*.

IBC 1106.9

(IBC 1106.9 is renumbered to 1106.10)

(IBC 1106.9.1 and 1106.9.2 are renumbered accordingly)

1106.10.3 Group I-2. In Group I-2 health care occupancies, at least one *accessible* entry shall be under shelter. Every such entry shall include a passenger loading zone.

(IBC 1106.9.3 and 1106.9.4 are renumbered accordingly)

Section 1107 Motor-Vehicle Related Facilities

IBC 1107

SECTION 1107 MOTOR-VEHICLE-RELATED FACILITIES

Not adopted

Reserved

Section 1108 Dwelling Units and Sleeping Units

IBC 1108.5

1108.5 Group I. *Accessible units*, Type A units and *Type B units* shall be provided in Group I occupancies in accordance with Sections 1108.5.1 through 1108.5.5.

1108.5.1 Group I-1. *Accessible units*, Type A units and *Type B units* shall be provided in Group I-1 occupancies in accordance with Sections 1108.5.1.1 and ~~1108.5.1.5-1108.5.1.3~~.

1108.5.1.1 Accessible units in Group I-1, Condition 1. In Group I-1, Condition 1, at least 4 percent, but not less than one, of the *dwelling units* and *sleeping units* shall be *accessible units*. Accessible *dwelling units* and *sleeping units* shall be dispersed among the various classes of units. *(The exceptions remain unchanged)*

1108.5.1.2.1 Assisted living and residential care facilities. All Group I-1, Condition 2 assisted living facilities and residential care facilities shall be provided with roll-in-type shower compartments in accordance with Section 1108.5.1.5.

1108.5.1.3 Type A units. In Group I-1, Condition 2 assisted living facilities and residential care facilities, every *dwelling unit* or *sleeping unit* shall be a *Type A unit* and shall be provided with bathing facilities in accordance with Section 1108.5.1.5.

(IBC 1108.5.1.3 is renumbered to 1108.5.1.4)

1108.5.1.5 Bathing facilities. Bathing facilities in Group I-1, Condition 2 assisted living facilities and residential care facilities shall comply with Section 1108.5.1.5.1 or 1108.5.1.5.2.

1108.5.1.5.1 Bathing facilities within the dwelling or sleeping unit. In all Group I-1,

Condition 2 assisted living facilities and residential care facilities where bathing facilities are provided within the dwelling or sleeping unit, one standard roll-in-type shower compartment shall be provided in each dwelling or sleeping unit. Grab bars shall be provided for water closets and shower compartments.

Exception: The folding seat is permitted to be omitted for standard roll-in-type shower compartments and the shower controls are permitted to be located on the side walls.

1108.5.1.5.2 Bathing facilities outside the dwelling or sleeping unit. In all Group I-1, Condition 2 residential care facilities where bathing facilities are provided outside the dwelling unit or sleeping unit, one standard roll-in-type shower compartment shall be provided in each bathing facility, except in a bathing room where an accessible tub is provided. Grab bars shall be provided for water closets and shower compartments.

Exception: The folding seat is permitted to be omitted for standard roll-in-type shower compartments and the shower controls are permitted to be located on the side walls.

(IBC 1108.5.2 remains unchanged)

1108.5.2.1 Accessible units. At least 50 percent but not less than one of each type of the dwelling units and sleeping units shall be Accessible units.

Exceptions: *(Exceptions 1 and 2 remain unchanged)*

3. In Group I-2, Condition 1 nursing homes, the folding seat is permitted to be omitted for standard roll-in-type shower compartments and the shower controls are permitted to be located on the side walls.

IBC 1108.6.4

1108.6.4 Group R-4. Accessible units, Type A units and Type B units shall be provided in Group R-4 occupancies in accordance with Sections 1108.6.4.1 and ~~1108.6.4.4~~ ~~1108.6.4.2~~. Bedrooms in Group R-4 facilities shall be counted as sleeping units for the purpose of determining the number of units.

1108.6.4.1 Accessible units. In Group R-4, Condition 1, at least one of the sleeping units shall be an Accessible unit. In Group R-4, Condition 2, at least 10 percent, but not less than one ~~two~~ of the sleeping units shall be an Accessible unit. All Group R-4, Condition 2 assisted living facility and residential care dwelling units and sleeping units shall be provided with bathing facilities in accordance with Section 1108.6.4.4.

1108.6.4.2 Type A units. In Group R-4, Condition 2 assisted living facilities and residential care facilities, every dwelling unit or sleeping unit shall be a Type A unit and shall be provided with bathing facilities in accordance with Section 1108.6.4.4.

(IBC 1108.6.4.2 is renumbered to 1108.6.4.3)

1108.6.4.4 Bathing facilities. Bathing facilities in Group R-4, Condition 2 assisted living facilities and residential care facilities shall comply with Section 1108.6.4.4.1 or 1108.6.4.4.2.

1108.6.4.4.1 Bathing facilities within dwelling or sleeping units. In all Group R-4, Condition 2 assisted living facilities and residential care facilities where bathing facilities are provided within the dwelling or sleeping unit, one standard roll-in-type shower compartment shall be provided in each dwelling or sleeping unit. Grab bars shall be provided for water closets and shower compartments.

Exception: The folding seat is permitted to be omitted for standard roll-in-type shower compartments and the shower controls are permitted to be located on the side walls.

1108.6.4.4.2 Bathing facilities outside dwelling or sleeping units. In all Group R-4, Condition 2 residential care facilities where bathing facilities are provided outside the dwelling or sleeping unit, one standard roll-in-type shower compartment shall be provided in each bathing facility, except in a bathing room where an accessible tub is provided. Grab bars shall be provided for water closets and shower compartments.

Exception: The folding seat is permitted to be omitted for standard roll-in-type shower compartments and the shower controls are permitted to be located on the side walls.

IBC 1108.7.5

1108.7.5 Flood hazard areas. Type A units and Type B units shall not be required for

buildings without elevator service that are located in *flood hazard areas* as established in Section 1612.3 and by the flood plain administrator, where the minimum required elevation of the *lowest floor* or lowest supporting horizontal structural member, as applicable, results in all of the following: *(The rest of this section remains unchanged)*

Section 1109 Special Occupancies

IBC 1109.2 **1109.2 Assembly area seating.** A building, room or space used for assembly purposes with *fixed seating* shall comply with Sections 1109.2.1 through 1109.2.5. Lawn seating that is serving an affected building on an affected building site shall comply with Section 1109.2.6. Assistive listening systems shall comply with Section 1109.2.7. Performance areas viewed from assembly seating areas shall comply with Section 1109.2.8. Dining areas shall comply with Section 1109.2.9.

IBC 1109.2.9 **1109.2.9 Dining and drinking areas.** In dining and drinking areas, all interior and exterior floor areas shall be *accessible* and be on an *accessible route*.

Exceptions:

1. An *accessible route* between *accessible* levels and stories above or below is not required where permitted by Section 1104.4, Exception 1.
- ~~2. An accessible route to dining and drinking areas in a mezzanine is not required, provided that the mezzanine contains less than 25 percent of the total combined area for dining and drinking and the same services, and decor are provided in the accessible area.~~
2. In sports facilities, tiered dining areas providing seating required to be *accessible* shall be required to have *accessible routes* serving at least 25 percent of the dining area, provided that *accessible routes* serve *accessible* seating and where each tier is provided with the same services.
3. Employee-only work areas shall comply with Sections 1103.2.2 and 1104.3.1.

1109.2.9.1 Dining surfaces. Where dining surfaces for the consumption of food or drink are provided, at least 5 percent, but not less than one, of the dining surfaces for the seating and standing spaces shall be *accessible* and be distributed throughout the facility and located on a level accessed by an *accessible route*.

Where a bar or counter exceeding 34 inches (864 mm) in height is provided for consumption of food or drink, a structurally integrated portion of the main bar or counter shall be provided, measuring a minimum 60 inches (1524 mm) long or 5 percent of the length, whichever is greater, and 28 to 34 inches (711 to 864 mm) high. Clear floor space for forward approach and knee and toe clearance shall be provided. Flip-up counters, adjacent tables and similar devices shall not be permitted to satisfy this requirement.

Section 1110 Other Features and Facilities

IBC 1110.9 **1110.9 Lifts.** Platform (wheelchair) lifts are permitted to be a part of a required *accessible route* in new construction where indicated in Items 1 through 10. Platform (wheelchair) lifts shall be installed in accordance with ~~ASME A18.1~~ the Elevator Code.

(1 through 5 remain unchanged)

~~6. An accessible route to load and unload areas serving amusement rides.~~

6. An *accessible route* to play components or *soft contained play structures*.

7. An *accessible route* to team or player seating areas serving *areas of sport activity*.

~~9. An accessible route instead of gangways serving recreational boating facilities and fishing piers and platforms.~~

8. An *accessible route* where existing exterior site constraints make use of a *ramp* or elevator infeasible.

IBC 1110.16 **1110.16 Gaming machines and gaming tables.** *Not adopted*

Section 1111 Recreational Facilities

IBC 1111 **1111.1 General.** Recreational facilities on affected building sites shall be provided with accessible features in accordance with Section 1102.1.2.8 and this section ~~1111.2 through 1111.4.~~

(Sections 1111.2 through 1111.3, 1111.4.2 through 1111.4.11, 1111.4.12.3, and 1111.4.14 through 1111.4.14.2 are not adopted. The remaining sections are renumbered accordingly)

1111.2.1 ~~1111.4.1~~ **Area of sport activity.** Each *area of sport activity* shall be on an *accessible route* ~~and shall not be required to be accessible except as provided for in Sections 1111.4.2 through 1111.4.15.~~

1111.2.2 ~~1111.4.12~~ **Miniature golf facilities.** ~~Miniature golf facilities shall comply with Sections 1111.4.12.1 through 1111.4.12.3.~~

Section 1112 Signage

IBC 1112 **1112.1 Signs.** Required accessible elements shall be identified by the International Symbol of Accessibility at the following locations.

1. Accessible parking spaces required by Section 1106.2.

~~**Exception:** Where the total number of parking spaces provided is four or less, identification of accessible parking spaces is not required.~~

(Items 2-10 remain unchanged)

1112.2 Signs identifying toilet or bathing rooms. Signs required by this code in Section 403.4 of the International Plumbing Code identifying toilet rooms and bathing rooms shall be visual characters, raised characters and braille complying with ICC A117.1. Where pictograms are provided as designations for toilet rooms and bathing rooms, the pictograms shall have visual characters, raised characters and braille complying with ICC A117.1.

1112.3 Directional signage. Directional signage indicating the route to the nearest like accessible element shall be provided at the following locations. These directional signs shall include the International Symbol of Accessibility and sign characters shall meet the visual character requirements in accordance with ICC A117.1.

(Item 1-6 remain unchanged)

- ~~6. Where drinking fountains for persons using wheelchairs and drinking fountains for standing persons are not located adjacent to each other, directional signage shall be provided indicating the location of the other drinking fountains.~~

1112.4 Other signs. Signage indicating special accessibility provisions shall be provided as shown.

(Item 1-6 remain unchanged)

- ~~7. Signs identifying the type of access provided on amusement rides required to be accessible by Section 1111.4.8 shall be provided at entries to queues and waiting lines. In addition, where accessible unload areas also serve as accessible load areas, signs indicating the location of the accessible load and unload areas shall be provided at entries to queues and waiting lines. These directional sign characters shall meet the visual character requirements in accordance with ICC A117.1.~~

Section 1113 Clustered Mailboxes

OSSC 1113

1113.1 Accessible routes. Clustered mailboxes on an affected building site shall be connected by an accessible route complying with Sections 402 and 403 of ICC A117.1.

1113.2 Location. Location of clustered mailboxes shall be coordinated with the postal authority having jurisdiction.

1113.2.1 Access to pedestrian circulation. Where an improved walking surface such as a sidewalk is located within 50 feet (15 240 mm) of the pad on which a clustered mailbox unit is located, at least one accessible route shall connect the improved walking surface to the clustered mailbox pad. At least one pedestrian access route shall be provided within 50 feet (15 240 mm) from the vehicular way to the pad on which a clustered mailbox unit is located.

1113.3 Ramps, curb ramps and barriers. Ramps along an accessible route to clustered mailboxes shall comply with Chapter 4 of ICC A117.1.

1113.3.1 Curb ramps. Where the accessible route to clustered mailboxes is obstructed by curbs, curb ramps shall be provided within 50 feet (15 240 mm) of the clustered mailbox location.

1113.3.2 Other barriers. Where barriers such as grass medians, landscaping or loose gravel between the edge of the traveled surface and clustered mailbox pads occur, a solid-surfaced access shall be provided within 50 feet (15 240 mm) of the clustered mailbox location.

1113.4 Turning space at clustered mailbox units. Not less than one turning space shall be provided at the front of each clustered mailbox. The turning space shall comply with ICC A117.1 and shall be either:

1. A circular space having a diameter not less than 72 inches (1829 mm).
2. A T-shaped space within a square not less than 72 inches (1829 mm) per side, with arms and base not less than 48 inches (1219 mm) wide. Each arm of the T shall be clear of obstructions not less than 24 inches (610 mm) in each direction, and the base shall be clear of obstructions not less than 36 inches (914 mm). The turning space shall be permitted to include knee and toe clearances only at the end of either the base or one arm.

1113.5 Clear floor space. Clear floor space in accordance with ICC A117.1, shall be provided at each mailbox within the clustered mailbox location. The required clear space and turning space may overlap.

CHAPTER 12

INTERIOR ENVIRONMENT

Section 1202 Ventilation

IBC 1202.1 **1202.1 General.** Buildings shall be provided with natural ventilation in accordance with Section 1202.5, or mechanical ventilation in accordance with the *International Mechanical Code*.

Where the air infiltration rate in a *dwelling unit* is less than 5 air changes per hour where tested with a blower door at a pressure 0.2 inch w.c. (50 Pa) in accordance with ~~the Energy Code Section R402.4.1.2 of the International Energy Conservation Code—Residential Provisions~~, the *dwelling units* shall be ventilated by mechanical means in accordance with Section 403 of the *International Mechanical Code*. *Ambulatory care facilities* and Group I-2 occupancies shall be ventilated by mechanical means in accordance with Section 407 of the *International Mechanical Code*.

IBC 1202.3 **1202.3 Unvented attic and unvented enclosed rafter assemblies.** Unvented *attics* and unvented enclosed roof framing assemblies created by ceilings applied directly to the underside of the roof framing members/rafters and the structural roof sheathing at the top of the roof framing members shall be permitted where all of the following conditions are met:

(Item 1 through 3 remain unchanged)

4. ~~In Climate Zones 5, 6, 7 and 8, any~~ **Any** *air-impermeable insulation* shall be a Class II vapor retarder or shall have a Class II vapor retarder coating or covering in direct contact with the underside of the insulation.
5. Insulation shall comply with either Item 5.1 or 5.2, and additionally Item 5.3.

(Item 5.1 through 5.1.4 remain unchanged)

~~5.2.—In Climate Zones 1, 2 and 3, air permeable insulation installed in unvented attics shall meet the following requirements:~~

~~5.2.1.—A vapor diffusion port shall be installed not more than 12 inches (305 mm) from the highest point of the roof, measured vertically from the highest point of the roof to the lower edge of the port.~~

~~5.2.2.—The port area shall be greater than or equal to $\frac{1}{600}$ of the ceiling area. Where there are multiple ports in the attic, the sum of the port areas shall be greater than or equal to the area requirement.~~

~~5.2.3.—The vapor permeable membrane in the vapor diffusion port shall have a vapor permeance rating of greater than or equal to 20 perms when tested in accordance with Procedure A of ASTM E96.~~

~~5.2.4.—The vapor diffusion port shall serve as an air barrier between the attic and the exterior of the building.~~

~~5.2.5.—The vapor diffusion port shall protect the attic against the entrance of rain and snow.~~

~~5.2.6.—Framing members and blocking shall not block the free flow of water vapor to the port. Not less than a 2 inch (50 mm) space shall be provided between any blocking and the roof sheathing. Air permeable insulation shall be permitted within that space.~~

~~5.2.7.—The roof slope shall be greater than or equal to 3 units vertical in 12 units horizontal (3:12).~~

~~5.2.8.—Where only air permeable insulation is used, it shall be installed directly below the structural roof sheathing, on top the attic floor, or on top of the ceiling.~~

~~5.2.9.—Where only air permeable insulation is used and is installed directly below the structural roof sheathing, air shall be supplied at a flow rate greater than or equal to 50 cubic feet per minute (23.6 L/s) per 1,000 square feet (93 m²) of ceiling.~~

~~5.3.—The air shall be supplied from ductwork providing supply air to the occupiable space when the conditioning system is operating. Alternatively, the air shall be supplied by a supply fan when the conditioning system is operating. Where preformed insulation board is used as the air impermeable insulation layer, it shall be sealed at the perimeter of each individual sheet interior surface to form a continuous layer.~~

(Exceptions remain unchanged)

IBC Table
1202.3

TABLE 1202.3
INSULATION FOR CONDENSATION CONTROL

CLIMATE ZONE	MINIMUM R-VALUE OF AIR-IMPERMEABLE INSULATION ^a
2B and 3B tile roof only	0 (none required)
1, 2A, 2B, 3A, 3B, 3C	R-5
4C	R-10
4A, 4B	R-15
5	R-20
6	R-25
7	R-30
8	R-35

a. Contributes to, but does not supersede, thermal resistance requirements for attic and roof assemblies in ~~Section C402.2.1 of the International Energy Conservation Code.~~

IBC 1202.4.3 **1202.4.3 Mechanical ventilation.** ~~Mechanical ventilation shall be provided to~~ The ground surface of mechanically ventilated crawl spaces ~~where the ground surface is shall be~~ covered with a Class I vapor retarder. Ventilation shall be in accordance with Section 1202.4.3.1 or 1202.4.3.2.

IBC 1202.4.4 **1202.4.4 Flood hazard areas.** For buildings in *flood hazard areas* as ~~established in Section 1612.3~~ established by the flood plain administrator, the openings for under-floor ventilation shall be deemed as meeting the flood opening requirements of ASCE 24 provided that the ventilation openings are designed and installed in accordance with ASCE 24.

Section 1210 Toilet and Bathroom Requirements

IBC 1210.1 **1210.1 Required fixtures.** The number and type of plumbing fixtures provided in any occupancy shall comply with Chapter 29. See Chapter 11 for accessibility requirements.

IBC 1210.3 **1210.3 Privacy.** Public restrooms shall be visually screened from outside entry or exit doorways to ensure user privacy within the restroom. ~~This provision shall also apply where mirrors would compromise personal privacy.~~ Privacy at water closets, single-user toilet and bathing rooms and urinals shall be provided in accordance with Sections 1210.3.1, ~~and~~ 1210.3.2 and 1210.3.3.

Exception: Visual screening shall not be required for single-occupant toilet rooms with a lockable door.

OSSC 1210.3.2 **1210.3.2 Single-user toilet and bathing rooms.** Doors to single-user toilet and bathing rooms, including family or assisted-use rooms, shall be securable from within the room and shall be provided with a privacy lock and an occupied indicator complying with Section 1010.2.

(IBC 1210.3.2 is renumbered to 1210.3.3)

OSSC 1210.4 **1210.4 Fixture clearances.** The centerline of water closets or bidets shall be not less than 15 inches (381 mm) to any side wall or obstruction, and at a spacing of not less than 30 inches (762 mm) from center to center of any fixture. The clear space in front of water closets and bidets in residential structures shall be not less than 21 inches (533 mm). For all other occupancies, the clear space in front of water closets and bidets shall be not less than 24 inches (610 mm). The centerline of urinals shall be not less than 12 inches (305 mm) from any side wall or partition and at a spacing of not less than 24 inches (610 mm) center to center of other urinals. The clear space from the front of urinals shall be not less than 24 inches (610 mm). Where plumbing fixtures are required to meet the accessibility requirements of this code, the installation shall comply with the requirements of Chapter 11 and ICC A117.1.

CHAPTER 14 EXTERIOR WALLS

Section 1402 Performance Requirements

IBC 1402.6 **1402.6 Flood resistance.** For buildings in *flood hazard areas* as established by the flood plain administrator ~~in Section 1612.3~~, exterior walls extending below the elevation required by Section 1612 shall be constructed with flood-damage-resistant materials.

IBC 1402.7 **1402.7 Flood resistance for coastal high-hazard areas and coastal A zones.** For buildings in *coastal high-hazard areas* and coastal A zones as established by the flood plain administrator ~~in Section 1612.3~~, electrical, mechanical and plumbing system components shall not be mounted on or penetrate through exterior walls that are **designed** to break away under *flood loads*.

Section 1404 Installation of Wall Coverings

IBC 1404.3 **1404.3 Vapor retarders.** Vapor retarder materials shall be classified in accordance with Table 1404.3(1). A vapor retarder shall be provided on the interior side of frame walls in accordance with Tables 1404.3(2) and 1404.3(3), or an approved design using accepted engineering practice for hygrothermal analysis. ~~The appropriate climate zone shall be selected in accordance with Chapter 3 of the International Energy Conservation Code.~~

IBC Table 1404.3(2)

**TABLE 1404.3(2)^{b,c}
VAPOR RETARDER OPTIONS**

CLIMATE ZONE	VAPOR RETARDER CLASS		
	I	II	III ^a
1, 2	Not permitted	Not Permitted	Permitted
3	Not permitted	Permitted	Permitted
3, 4 (except Marine 4)	Not permitted	Permitted	Permitted
Marine 4, 5, 6, 7, 8	Permitted	Permitted	See Table 1404.3(3)

a. See also Section 1404.3.1 and 1404.3.2.

b. Zone Marine 4 includes the following counties: Benton, Clackamas, Clatsop, Columbia, Coos, Curry, Douglas, Jackson, Josephine, Lane, Lincoln, Linn, Marion, Multnomah, Polk, Tillamook, Washington and Yamhill.

c. Zone 5 includes the counties not listed in Zone Marine 4.

IBC Table 1404.3(3)

**TABLE 1404.3(3)
CLASS III VAPOR RETARDERS**

ZONE	CLASS III VAPOR RETARDERS PERMITTED FOR: ^{a,b}
4 ^c	Vented cladding over wood structural panels Vented cladding over fiberboard Vented cladding over gypsum Continuous insulation with <i>R</i> -value \geq R-2.5 over 2 × 4 wall Continuous insulation with <i>R</i> -value \geq R-3.75 over 2 × 6 wall
5 ^d	Vented cladding over wood structural panels Vented cladding over fiberboard Vented cladding over gypsum Continuous insulation with <i>R</i> -value \geq R-5 over 2 × 4 wall Continuous insulation with <i>R</i> -value \geq R-7.5 over 2 × 6 wall
6	Vented cladding over fiberboard Vented cladding over gypsum Continuous insulation with <i>R</i> value \geq R 7.5 over 2 × 4 wall Continuous insulation with <i>R</i> value \geq R 11.25 over 2 × 6 wall
7	Continuous insulation with <i>R</i> value \geq R 10 over 2 × 4 wall Continuous insulation with <i>R</i> value \geq R 15 over 2 × 6 wall
8	Continuous insulation with <i>R</i> value \geq R 12.5 over 2 × 4 wall Continuous insulation with <i>R</i> value \geq R 20 over 2 × 6 wall

(Footnote a. remains unchanged)

b. The requirements in this table apply only to insulation used to control moisture in order to permit the use of Class III vapor retarders. The insulation materials used to satisfy this option also contribute to but do not supersede the thermal envelope requirements of the *International Energy Conservation Code*.

c. Zone Marine 4 includes the following counties: Benton, Clackamas, Clatsop, Columbia, Coos, Curry, Douglas, Jackson, Josephine, Lane, Lincoln, Linn, Marion, Multnomah, Polk, Tillamook, Washington and Yamhill.

d. Zone 5 includes the counties not listed in Zone Marine 4.

IBC Table
1404.3(4)

TABLE 1404.3(4)
CONTINUOUS INSULATION WITH CLASS II VAPOR RETARDER

CLIMATE ZONE	PERMITTED CONDITIONS ^a
3	Continuous insulation with R-value \geq R-2
4, 5, 6	Continuous insulation with R-value \geq R-3 over 2 x 4 wall Continuous insulation with R-value \geq R-5 over 2 x 6 wall
7	Continuous insulation with R-value \geq R-5 over 2 x 4 wall Continuous insulation with R-value \geq R-7.5 over 2 x 6 wall
8	Continuous insulation with R-value \geq R-7.5 over 2 x 4 wall Continuous insulation with R-value \geq R-10 over 2 x 6 wall

(The footnote remains unchanged)

IBC 1404.4

1404.4 Flashing. Flashing shall be installed in such a manner so as to prevent moisture from entering the wall or to redirect that moisture to the surface of the exterior wall finish or to a *water-resistive barrier* complying with Section 1403.2 and that is part of a means of drainage complying with Section 1402.2. Flashing shall be installed at the perimeters of exterior door and window assemblies, penetrations and terminations of *exterior wall* assemblies, *exterior wall* intersections with roofs, chimneys, porches, decks, balconies and similar projections and at built-in gutters and similar locations where moisture could enter the wall. Flashing with projecting flanges shall be installed on both sides and the ends of copings, under sills and continuously above projecting trim. Where self-adhered membranes are used as flashings of *fenestration* in wall assemblies, those self-adhered flashings shall comply with AAMA 711. Where fluid applied membranes are used as flashing for *exterior wall* openings, those fluid applied membrane flashings shall comply with AAMA 714.

Where a Class II vapor retarder is used in combination with foam plastic insulating sheathing installed as continuous insulation on the exterior side of frame walls, the continuous insulation shall comply with Table 1404.3(4) and the Class II vapor retarder shall have a vapor permeance greater than 1 perm when measured by ASTM E96 water method (Procedure B). Use of a Class I interior vapor retarder in frame walls with a Class I vapor retarder on the exterior side shall require an approved design.

Exceptions:

1. Basement walls.
2. Below-grade portion of any wall.
3. [Masonry walls with exposed interior surfaces.](#)
4. [Where exterior continuous rigid insulation is at least 50 percent of the required R-value for that wall assembly, a Class I or Class II vapor retarder may be installed on the interior surface of rigid insulation.](#)
5. Construction where accumulation, condensation or freezing of moisture will not damage the materials.
6. Class I and II vapor retarders with vapor permeance greater than 1 perm when measured by ASTM E96 water method (Procedure B) shall be allowed on the interior side of any frame wall in all climate zones.

IBC 1404.10.3

1404.10.3 Interior adhered masonry veneers. Interior *adhered masonry veneers* shall have a maximum weight of 20 psf (0.958 kg/m²) and shall be installed in accordance with Section 1404.10. Where the interior *adhered masonry veneer* is supported by wood construction, the supporting members shall be designed to limit deflection to ¹/₆₀₀ of the span of the supporting members.

Exception: Where interior *adhered masonry veneer* can be demonstrated to support its own weight and the lateral load for the interior *adhered masonry veneer* is provided through the use of an engineered system, the 20 psf (97.6 kg/m²) limitation does not apply.

IBC 1404.11.4

1404.11.4 Grounding. Grounding of metal *veneers* on buildings shall comply with the requirements of Chapter 27 of this code [Electrical Code](#).

Section 1407 Exterior Insulation and Finish Systems (EIFS)

IBC 1407.4.1 **1407.4.1 EIFS with drainage required.** ~~EIFS with drainage shall have an average minimum drainage efficiency of 90 percent when tested in accordance the requirements of ASTM E2273 and is required on framed walls of Type V construction, Group R1, R2, R3 and R4 occupancies. All EIFS shall be provided with a drainage system.~~

Exception: EIFS without drainage barrier systems are permitted to be used in the following applications:

1. *Repairs to existing barrier systems.*
2. *Architectural features not protecting an interior space.*
3. *Installation on concrete and concrete masonry unit (CMU) surfaces.*

IBC 1407.4.1.1 **1407.4.1.1 Water-resistive barrier.** *Not adopted*

IBC 1407.5 **1407.5 Installation.** Installation of ~~the EIFS and~~ EIFS with drainage shall be in accordance with the EIFS manufacturer's instructions.

CHAPTER 15

ROOF ASSEMBLIES AND ROOFTOP STRUCTURES

Section 1501 General

IBC 1501.1 **1501.1 Scope.** The provisions of this chapter shall govern the design, materials, construction and quality of *roof assemblies*, and *rooftop structures*.

The following information regarding the installation of roof fall protection systems is not part of this code and is provided solely for the reader's consideration:

Integration of roof fall protection systems into the building design is not required by law. For information about worker fall protection systems, designers are encouraged to consult Oregon OSHA administrative rules for worker fall protection systems, located in OAR Chapter 437, Division 3, Subdivision M-1926.502, Fall Protection Systems Criteria and Practices.

Section 1502 Roof Drainage

IBC 1502.1 **1502.1 General.** Design and installation of roof drainage systems shall comply with this section, ~~Section 1611 of this code and Chapter 11 of the *International Plumbing Code*.~~

1502.1.1 General requirements. Where required by the *municipality*, a *drainage system*, which may include gutters, drains or necessary associated piping, shall be installed. Roofs shall be sloped a minimum of 1 unit vertical in 48 units horizontal (2-percent slope) for drainage unless designed for water accumulation in accordance with Section 1611.2 and approved by the *building official*.

1502.1.2 Roof drains. Unless roofs are sloped to drain over roof edges, roof drains shall be installed at each low point of the roof. Roof drains shall be sized and discharged in accordance with the *Plumbing Code*.

1502.1.3 Overflow drains and scuppers. Where roof drains are required, overflow drains shall be installed in accordance with the *Plumbing Code*.

1502.1.4 Concealed piping. Roof drains and overflow drains, where concealed within the construction of the building, shall be installed in accordance with the *Plumbing Code*.

1502.1.5 Over public property. Roof drainage water from a building shall not be permitted to flow over public property.

Exception: Group R-3 and Group U occupancies.

IBC 1502.2 **1502.2 Secondary (emergency overflow) drains or scuppers.** *Not adopted*

IBC 1502.3 **1502.3 Scuppers.** *Not adopted*

IBC 1502.4 **1502.4 Gutters.** *Not adopted*

Section 1504 Performance Requirements

IBC Table 1504.2

TABLE 1504.2
CLASSIFICATION OF STEEP SLOPE ROOF SHINGLES TESTED IN ACCORDANCE WITH ASTM D3161 OR D7158

MAXIMUM BASIC WIND SPEED, V, FROM FIGURES TABLE 1609.3(4) (8) OR ASCE 7 (mph)	MAXIMUM ALLOWABLE STRESS DESIGN WIND SPEED, V_{asd} , FROM Table 1609.3.1 (mph)	ASTM D7158 ^a CLASSIFICATION	ASTM D3161 or UL 7103 CLASSIFICATION
110	85	D, G or H	A, D or F
116	90	D, G or H	A, D or F
129	100	G or H	A, D or F
142	110	G or H	F
155	120	G or H	F
168	130	H	F
181	140	H	F
194	150	H	F

Section 1505 Fire Classification

IBC Table 1505.1

TABLE 1505.1
MINIMUM ROOF COVERING CLASSIFICATION FOR TYPES OF CONSTRUCTION^{a,b}

I-A	I-B	II-A	IIB	III-A	III-B	IV	V-A	V-B
B	B	B	C ^{e,b}	B	C ^{e,b}	B	B	C ^c

For SI: 1 foot = 304.8 mm, 1 square foot = 0.0929 m².

~~a. Unless otherwise required in accordance with the International Wildland-Urban Interface Code or due to the location of the building within a fire district in accordance with Appendix D.~~

~~a,b.~~ Nonclassified roof coverings shall be permitted on buildings of Group R3 and Group U occupancies, where there is a minimum fire-separation distance of 6 feet measured from the leading edge of the roof.

~~b,e.~~ Buildings that are not more than two stories above grade plane and having not more than 6,000 square feet of projected roof area and where there is a minimum 10-foot fire-separation distance from the leading edge of the roof to a lot line on all sides of the building, except for street fronts or public ways, shall be permitted to have roofs of No. 1 cedar or redwood shakes and No. 1 shingles constructed in accordance with Section 1505.7.

IBC 1505.9

1505.9 Rooftop mounted photovoltaic (PV) panel systems. Rooftop mounted *photovoltaic (PV) panel systems* shall ~~be~~ have noncombustible racking and mounting systems, or be tested, listed and identified with a fire classification in accordance with UL 2703. Listed systems shall be installed in accordance with the manufacturer's installation instructions and their listing. The fire classification shall comply with Table 1505.1 based on the type of construction of the building.

Section 1507 Requirements for Roof Coverings

IBC 1507.15

1507.15 Vegetative roofs and landscaped roofs. *Vegetative roofs* and landscaped roofs shall comply with the requirements of this chapter, ~~and~~ Section 1607.14.2.2 ~~and the International Fire Code.~~

OSSC 1507.15.2

~~**1507.15.2 Landscaped roof size.** Landscaped roof areas shall not exceed 15,625 square feet (1452 m²) in size for any single area with a maximum dimension of 125 feet (38 m) in length or width. A minimum 6-foot-wide (1829 mm) clearance consisting of a listed Class A roof assembly tested in accordance with ASTM E108 or UL 790 shall be provided between adjacent landscaped roof areas.~~

OSSC 1507.15.3

~~**1507.15.3 Rooftop structure and equipment clearance.** For all vegetative roofs abutting combustible vertical surfaces, a Class A-rated roof system complying with ASTM E108 or UL 790 shall be achieved for a minimum 6-foot-wide (1829 mm) continuous border placed around rooftop structures and all rooftop equipment, including but not limited to, mechanical and machine rooms, penthouses, skylights, roof vents, solar panels, antenna supports and building service equipment.~~

- IBC 1507.16** **1507.16 Photovoltaic shingles.** The installation of *photovoltaic shingles* shall comply with the provisions of this section [and Section 3111](#).
- IBC 1507.16.8** **1507.16.8 Wind resistance.** *Photovoltaic shingles* shall comply with the classification requirements of Table 1504.2 for the appropriate maximum ~~nominal design~~ [basic](#) wind speed.

Section 1512 Reroofing

- IBC 1512.1** **1512.1 General.** Materials and methods of application used for recovering or replacing an existing *roof covering* shall comply with the requirements of Chapter 15 [and the Energy Code](#).
- Exceptions:**
- ~~1.—Roof replacement or roof recover of existing low-slope roof coverings shall not be required to meet the minimum design slope requirement of 1/4 unit vertical in 12 units horizontal (2-percent slope) in Section 1507 for roofs that provide positive roof drainage.~~
 - ~~2.—Recovering or replacing an existing roof covering shall not be required to meet the requirement for secondary (emergency overflow) drains or scuppers in Section 1502.2 for roofs that provide for positive roof drainage. For the purposes of this exception, existing secondary drainage or scupper systems required in accordance with this code shall not be removed unless they are replaced by secondary drains or scuppers designed and installed in accordance with Section 1502.2.~~
- OSSC 1512.2.2** **[1512.2.2 Reroofing inspection.](#)** [Where required by the building official, an inspection prior to the installation of new roof coverings shall be conducted to verify that the conditions of Section 1512.2.1 are met. The building official may accept inspection reports prepared by an approved agency.](#)
- OSSC 1512.2.3** **[1512.2.3 Final inspection.](#)** [A final inspection and approval shall be obtained from the building official when the reroofing is complete.](#)

CHAPTER 16

STRUCTURAL DESIGN

Section 1603 Construction Documents

- IBC 1603.1** **1603.1 General.** *Construction documents* shall show the size, section and relative locations of structural members with floor levels, column centers and offsets dimensioned. The design loads and other information pertinent to the structural design required by Sections 1603.1.1 through 1603.1.9 shall be indicated on the *construction documents*.
- Exception:** *Construction documents* for buildings constructed in accordance with the *conventional light-frame construction* provisions of Section 2308 shall indicate the following structural design information:
- (Exception 1 – 4 remain unchanged)*
5. Flood design data, if located in *flood hazard areas* established by the flood plain administrator in Section 1612.3.
 6. Design load-bearing values of soils.
 7. Rain load data, where pertinent to the structural design (see Section 1611).
- IBC 1603.1.3** **1603.1.3 Roof snow load data.** The ground snow *load*, p_g , shall be indicated. ~~In areas where the ground snow load, p_g , exceeds 10 pounds per square foot (psf) (0.479 kN/m²),~~ The following additional information shall also be provided, regardless of whether snow *loads* govern the design of the roof: *(The rest of 1603.1.3 remains unchanged)*
- IBC 1603.1.4** **1603.1.4 Wind design data.** The following information related to wind *loads* shall be shown, regardless of whether wind *loads* govern the design of the lateral force-resisting system of the structure:
- (Exception 1 – 4 remain unchanged)*
5. Design wind pressures ~~and their applicable zones with dimensions~~ to be used for exterior component and cladding materials not specifically designed by the *registered design professional* responsible for the design of the structure, pounds per square foot (kN/m²).
- IBC 1603.1.7** **1603.1.7 Flood design data.** For buildings located in whole or in part in *flood hazard areas* as established in Section 1612.3, the documentation pertaining to design, if required in Section 1612.4, shall be included, ~~and the following information, referenced to the datum on the community's Flood Insurance Rate Map (FIRM), shall be shown, regardless of whether flood loads govern the design of the building:~~
- ~~1. Flood design class assigned according to ASCE 24.~~
 - ~~2. In flood hazard areas other than coastal high hazard areas or coastal A zones, the elevation of the proposed lowest floor, including the basement.~~
 - ~~3. In flood hazard areas other than coastal high hazard areas or coastal A zones, the elevation to which any nonresidential building will be dry floodproofed.~~
 - ~~4. In coastal high hazard areas and coastal A zones, the proposed elevation of the bottom of the lowest horizontal structural member of the lowest floor, including the basement.~~
- IBC 1603.1.9** **1603.1.9 Roof rain load data.** Rain intensity, i (in/hr) (cm/hr), shall be shown ~~regardless of whether rain loads govern~~ where pertinent to the structural design (see Section 1611).

Section 1604 General Design Requirements

IBC 1604.4 **1604.4 Analysis.** *Load effects* on structural members and their connections shall be determined by methods of structural analysis that take into account equilibrium, general stability, geometric compatibility and both short- and long-term material properties.

Members that tend to accumulate residual deformations under repeated service *loads* shall have included in their analysis the effects of added deformations expected to occur during their service life.

Any system or method of construction to be used shall be based on a rational analysis in accordance with well-established principles of mechanics. Such analysis shall result in a system that provides a complete *load path* capable of transferring *loads* from their point of origin to the load-resisting elements.

The total lateral force shall be distributed to the various vertical elements of the lateral force-resisting system in proportion to their rigidities, considering the rigidity of all horizontal and vertical elements part of the lateral force-resisting system ~~the horizontal bracing system or diaphragm~~. Rigid elements assumed not to be a part of the lateral force-resisting system are permitted to be incorporated into buildings provided that their effect on the action of the system is considered and they are detailed to accommodate the building drift provided for in the design. A *diaphragm* ~~is~~ may be considered rigid for the purpose of distribution of *story* shear and torsional moment as allowed by ASCE 7 Section 12.3 ~~when the lateral deformation of the diaphragm is less than or equal to two times the average story drift~~. Where required by ASCE 7, provisions shall be made for the increased forces induced on resisting elements of the structural system resulting from torsion due to eccentricity between the center of application of the lateral forces and the center of rigidity of the lateral force-resisting system.

Every structure shall be designed to resist the effects caused by the forces specified in this chapter, including overturning, uplift and sliding. Where sliding is used to isolate the elements, the effects of friction between sliding elements shall be included as a force.

IBC 1604.5 **1604.5 Risk category.** Each building and structure shall be assigned a *risk category* in accordance with Table 1604.5. Where a referenced standard specifies an occupancy category, the *risk category* shall not be taken as lower than the occupancy category specified therein. Where a referenced standard specifies that the assignment of a *risk category* be in accordance with ASCE 7, Table 1.5-1, Table 1604.5 shall be used in lieu of ASCE 7, Table 1.5-1.

~~**Exception:** The assignment of buildings and structures to Tsunami Risk Categories III and IV is permitted to be in accordance with Section 6.4 of ASCE 7.~~

IBC Table 1604.5

**TABLE 1604.5
RISK CATEGORY OF BUILDINGS AND OTHER STRUCTURES**

(All other parts of Table 1604.5 remain unchanged)

RISK CATEGORY	NATURE OF OCCUPANCY
III	Buildings and other structures that represent a substantial hazard to human life in the event of failure, including but not limited to: <ul style="list-style-type: none"> Buildings and other structures containing one or more public-assembly spaces, each having an occupant load greater than 300 and a cumulative occupant load of these public-assembly spaces of greater than 2,500. Buildings and other structures not included in Risk Category IV containing quantities of toxic or explosive materials that: <ul style="list-style-type: none"> Exceed maximum allowable quantities per control area as given in Table 307.1(1) or 307.1(2) or per outdoor control area in accordance with the International Fire Code; and Are sufficient to pose a threat to the public if released.^b
IV	Buildings and other structures designated as essential facilities, including but not limited to: <ul style="list-style-type: none"> Buildings and other structures containing quantities of highly toxic materials that: <ul style="list-style-type: none"> Exceed maximum allowable quantities per control area as given in Table 307.1(2) or per outdoor control area in accordance with the International Fire Code; and Are sufficient to pose a threat to the public if released.^b

Section 1606 Dead Loads

OSSC 1606.4.1 [1606.4.1 Solar-ready roofs](#). Where roofs are required to be provided with a *solar-ready zone*, a collateral *dead load* shall be included in the gravity design of the building in accordance with [Section 3111.4](#).

Section 1607 Live Loads

IBC Table 1607.1

TABLE 1607.1
MINIMUM UNIFORMLY DISTRIBUTED LIVE LOADS, L_o ,
AND MINIMUM CONCENTRATED LIVE LOADS

(All other parts of Table 1604.5 remain unchanged)

OCCUPANCY OR USE		UNIFORM (psf)	CONCENTRATED (pounds)	ALSO SEE SECTION
6.	Catwalks, mechanical rooms , and elevated platforms for maintenance and service access	40 ^d	300	—
33.	Storage warehouses except for one- and two-family dwellings (shall be designed for heavier loads if required for anticipated storage)	Heavy	—	—
		Light		
38.	Exterior foot bridge (where part of the means of egress or an accessible route)	100	1,000	—

(a – c remain unchanged)

d. [Weight of mechanical equipment shall be included as dead loads in accordance with Section 1606.3](#).

IBC 1607.14.2.2 **1607.14.2.2 Occupiable roofs**. Areas of [occupiable roofs](#), ~~other than those used for assembly purposes that are occupiable~~, such as *vegetative roofs*, landscaped roofs ~~or for assembly or other similar purposes~~, and *marquees*, are permitted to have their uniformly distributed *live loads* reduced in accordance with Section 1607.12.

Section 1608 Snow Loads

IBC 1608.1 **1608.1 General**. Design snow *loads* shall be determined in accordance with Chapter 7 of ASCE 7, [as modified](#) ~~but the design roof load shall be not less than that determined by Section 1607-1608.2~~.

IBC 1608.2 **1608.2 Ground snow loads**. *(Not adopted)*
 Table 1608.2 Ground snow loads, p_g , for Alaskan locations *(Not adopted)*
 Figure 1608.2(1) Ground snow loads, p_g , for the United States (psf) *(Not adopted)*
 Figure 1608.2(2) Ground snow loads, p_g , for the United States (psf) *(Not adopted)*

OSSC 1608.2 [1608.2 Modifications to ASCE 7](#). The text of ASCE 7 shall be modified as indicated in Sections 1608.2.1 through 1608.2.5.

[1608.2.1 ASCE 7, Section 7.1](#). Modify ASCE 7, Section 7.1.2, *Symbols*, meaning of p_g , to read as follows:

p_g = [ground snow load as determined from Section 1608.2.2 or 1608.3 of the Building Code](#), in lb/ft² (kN/m²)

[1608.2.2 ASCE 7, Section 7.2](#). Modify ASCE 7, Section 7.2, Ground snow loads, p_g , to read as follows:

Ground snow *loads*, p_g , to be used in the determination of design snow *loads* for roofs shall be those set forth in the online lookup tool at <http://snowload.seao.org/lookup.html> published by the Structural Engineers Association of Oregon. Where the site elevation is higher than the

modeled elevation reported by the online lookup tool, the reported ground snow load values shall be adjusted by adding the specified loads from Table 7.2.

The importance factor times the ground snow load, $I_s p_g$, shall be used as the balanced snow load for snow accumulation surfaces, such as decks, balconies, and other near-ground level surfaces or roofs of subterranean spaces, whose height above the ground surface is less than the depth of the ground snow, h_g ($h_g = p_g / \gamma$).

Exception: Ground snow loads determined in accordance with Section 1608.3 of the Building Code.

**TABLE 7.2
GROUND SNOW LOAD ADJUSTMENT**

REGION	GROUND SNOW ADJUSTMENT LOADS (psf per foot of elevation gain)
Oregon Coast Mountains	0.07
Interior and Willamette Valleys	0.04
Cascade Mountains	0.07
Siskiyou and Kalmiopsis Mountains	0.04
Plains east of the Cascades	0.007
Klamath Basin	0.008
Eastern Oregon Mountains	0.04

1608.2.3 ASCE 7, Section 7.3.4. Modify ASCE 7, Section 7.3.4, Minimum Snow Load for Low-Slope Roofs, p_m , to read as follows:

The roof snow load for monoslope, hip and gable roofs with slopes less than 15 degrees and for curved roofs where the vertical angle from the eaves to the crown is less than 10 degrees shall be not less than 20 psf times the importance factor, I_s , plus the rain-on-snow surcharge determined from Section 7.10. This minimum roof snow load is a separate uniform load case and need not be used in determining or in combination with drift, sliding, unbalanced or partial loads.

1608.2.4 ASCE 7, Section 7.4. Modify ASCE 7, Section 7.4, Sloped Roof Snow Loads, p_s , to add the following:

The sloped roof snow load, p_s , used for design shall be not less than 20 psf times the importance factor, I_s , plus the rain-on-snow surcharge determined from Section 7.10. This minimum sloped roof snow load is a separate uniform load case and need not be used in determination of or in combination with drift, sliding, unbalanced or partial loads.

1608.2.5 ASCE 7, Section 7.10. Modify ASCE 7, Section 7.10, Rain-on-Snow Surcharge Load, to read as follows:

A 5 psf rain-on-snow surcharge shall be added to the minimum roof snow load determined from Sections 7.3.4 and 7.4 where any of the following conditions exist:

1. All roofs having a slope less than or equal to 1 unit vertical in 12 units horizontal (1:12).
2. Roofs of any slope that constrain runoff of the drainage system by parapets or other physical obstructions and are capable of accumulating more than 1 inch of standing water on any part of the roof. Structures with a continuous gutter at the low-point eave or comparable system shall not be considered as having constrained runoff.

Exception: The 5 psf rain-on-snow surcharge need not apply to roofs, of any slope, where all of the following conditions exist:

1. The roof drainage is not constrained.
2. The mapped ground snow load, p_g , is less than 15 psf.
3. The structure lies west of the Coast Range crest or east of the Cascade Range crest. At the most northern point of the Coast Range crest, the dividing line shall be the county line between Clatsop and Columbia counties.

1608.3 Site-specific snow load study. Where ground snow loads determined from Section 1608.2.2 exceed the location-specific threshold loads in Table 1608.3, an approved site-specific snow load study is required to determine the ground snow load used for design. The ground snow load determination from a site-specific study shall be based on an extreme value

statistical analysis of data available in the vicinity of the site using a value with a 2-percent annual probability of being exceeded (50-year mean recurrence interval).

TABLE 1608.3
LOCATIONS AND CRITERIA FOR SITE-SPECIFIC GROUND SNOW LOAD STUDY REQUIREMENT

<u>LOCATION</u>	<u>GROUND SNOW THRESHOLD LOADS FOR SITE-SPECIFIC STUDY (psf)</u>
<u>Oregon Coast Mountains</u>	<u>100</u>
<u>Cascade Mountains</u>	<u>350</u>
<u>Siskiyou and Kalmiopsis Mountains</u>	<u>200</u>
<u>Eastern Oregon Mountains</u>	<u>200</u>

IBC 1608.3 *Renumbered to 1608.4*

Section 1609 Wind Loads

IBC 1609.1.1 **1609.1.1 Determination of wind loads.** Wind loads on every building or structure shall be determined in accordance with Chapters 26 to 30 of ASCE 7 using. ~~The type of opening protection required,~~ the basic design wind speed, V , as determined by Section 1609.3. ~~and~~ The exposure category for a site is permitted to be determined in accordance with Section 1609 or ASCE 7. Wind shall be assumed to come from any horizontal direction and wind pressures shall be assumed to act normal to the surface considered.

Exceptions: *(Exceptions 1 – 3 remain unchanged)*

4. Designs using NAAMM FP 1001. The basic design wind speeds, V , used for the design shall be determined by Section 1609.3.
5. Designs using TIA-222 for antenna-supporting structures and antennas, provided that the horizontal extent of Topographic Category 2 escarpments in Section 2.6.6.2 of TIA-222 shall be 16 times the height of the escarpment. The basic design wind speeds, V , used for the design shall be determined by Section 1609.3.
6. Wind tunnel tests in accordance with ASCE 49 and ~~Sections 31.4 and 31.5~~ Chapter 31 of ASCE 7, as modified by Section 1609.2.

The wind speeds in Table 1609.3 ~~Figures 1609.3(1) through 1609.3(12)~~ are basic design wind speeds, V , and shall be converted in accordance with Section 1609.3.1 to allowable stress design wind speeds, V_{asd} , when the provisions of the standards referenced in Exceptions 4 and 5 are used.

IBC 1609.2 **1609.2 Protection of openings.** *(Not adopted)*
1609.2.1 Louvers. *(Not adopted)*
1609.2.2 Application of ASTM E1996. *(Not adopted)*
1609.2.3 Garage doors. *(Not adopted)*
Table 1609.2 Windborne debris protection fastening ... *(Not adopted)*

OSSC 1609.2 **1609.2 ASCE 7, Section 31.6.1.2. Modify ASCE 7, Section 31.6.1.2, Peer Review Requirements for Wind Tunnel Tests of Roof-Mounted Solar Connectors, last paragraph to read as follows:**

The peer reviewer shall submit a written report to the municipality and the client. The report shall include, at a minimum, statements regarding the following: scope of peer review with limitations defined; status of wind tunnel test at the time of review; conformance of wind tunnel study with requirements of ASCE 49 and Section 31.6.1; conclusion of the reviewer identifying areas that need further review, investigation and/or clarification; recommendations; and statement from the reviewer that in their opinion the results of the wind tunnel tests have correctly been applied to the specific situation/project that the results of the wind tunnel tests

are being applied to and that the final design conforms to the requirements of ASCE 7-16 for the intended use(s).

- IBC 1609.3** **1609.3 Basic design wind speed.** *(Not adopted)*
Figure 1609.3(1) Basic design wind speeds, V, for Risk Category II ... *(Not adopted)*
Figure 1609.3(2) Basic design wind speeds, V, for Risk Category III ... *(Not adopted)*
Figure 1609.3(3) Basic design wind speeds, V, for Risk Category IV ... *(Not adopted)*
Figure 1609.3(4) Basic design wind speeds, V, for Risk Category I ... *(Not adopted)*
Figure 1609.3(5) Basic design wind speeds, V, for Risk Category II ... in Hawaii *(Not adopted)*
Figure 1609.3(6) Basic design wind speeds, V, for Risk Category II ... in Hawaii *(Not adopted)*
Figure 1609.3(7) Basic design wind speeds, V, for Risk Category III ... in Hawaii *(Not adopted)*
Figure 1609.3(8) Basic design wind speeds, V, for Risk Category III ... in Hawaii *(Not adopted)*
Figure 1609.3(9) Basic design wind speeds, V, for Risk Category IV ... in Hawaii *(Not adopted)*
Figure 1609.3(10) Basic design wind speeds, V, for Risk Category IV ...in Hawaii *(Not adopted)*
Figure 1609.3(11) Basic design wind speeds, V, for Risk Category I ... in Hawaii *(Not adopted)*
Figure 1609.3(12) Basic design wind speeds, V, for Risk Category I ... in Hawaii *(Not adopted)*

OSSC 1609.3 **1609.3 Basic design wind speed.** The basic design wind speed, V, in mph, for the determination of the wind loads shall be determined by Table 1609.3. Areas of special wind regions in Table 1609.3 shall be identified using Figure 1609.3.

**OSSC Table
1609.3**

**TABLE 1609.3
BASIC DESIGN WIND SPEED, V, FOR RISK CATEGORY I, II, III AND IV BUILDINGS AND OTHER STRUCTURES**

COUNTY	RISK CATEGORY I BASIC DESIGN WIND SPEED, V (MPH)	RISK CATEGORY II BASIC DESIGN WIND SPEED, V (MPH)	RISK CATEGORY III BASIC DESIGN WIND SPEED, V (MPH)	RISK CATEGORY IV BASIC DESIGN WIND SPEED, V (MPH)
Baker	97	103	110	114
Benton	90	96	102	107
Clackamas	92	98	105	109
Clackamas special wind region ^a	115	120	130	130
Clatsop	91	96	102	107
Clatsop special wind region ^a	125	135	145	145
Columbia	91	97	103	107
Columbia special wind region ^a	115	120	130	130
Coos	89	95	101	106
Coos special wind region ^{a, b}	115 ^b	120 ^b	130 ^b	130 ^b
Crook	93	100	106	111
Crook special wind region ^a	100	110	115	115
Curry	88	94	101	105
Curry special wind region ^a	125	135	145	145
Deschutes	93	99	106	110
Deschutes special wind region ^a	100	110	115	115
Douglas	91	97	103	108
Douglas special wind region ^{a, b}	115 ^b	120 ^b	130 ^b	130 ^b
Gilliam ^d	94 ^d	100 ^d	107 ^d	111 ^d
Grant	95	101	108	113
Harney	94	101	108	112
Hood River ^c	92 ^c	98 ^c	105 ^c	109 ^c
N.45.5° special wind region ^{a,c}	115 ^c	120 ^c	130 ^c	130 ^c
S.45.5° special wind region ^a	100	110	115	115

Jackson	90	96	103	107
Jefferson	93	99	106	110
Jefferson special wind region ^a	100	110	115	115

(continued)

TABLE 1609.3—continued
BASIC DESIGN WIND SPEED, V, FOR RISK CATEGORY I, II, III AND IV BUILDINGS AND OTHER STRUCTURES

COUNTY	RISK CATEGORY I BASIC DESIGN WIND SPEED, V (MPH)	RISK CATEGORY II BASIC DESIGN WIND SPEED, V (MPH)	RISK CATEGORY III BASIC DESIGN WIND SPEED, V (MPH)	RISK CATEGORY IV BASIC DESIGN WIND SPEED, V (MPH)
Josephine	89	95	102	106
Klamath	91	98	104	108
Klamath special wind region ^a	115	120	130	130
Lake	93	99	106	111
Lane	91	98	105	110
Lane special wind region ^{a, b}	115 ^b	120 ^b	130 ^b	130 ^b
Lincoln	90	96	102	106
Lincoln special wind region ^a	125	135	145	145
Linn	92	98	104	108
Malheur	96	102	109	113
Marion	92	98	104	108
Morrow ^d	94 ^d	101 ^d	108 ^d	112 ^d
Multnomah ^c	92 ^c	98 ^c	105 ^c	110 ^c
Multnomah special wind region ^{a, c}	115 ^c	120 ^c	130 ^c	130 ^c
Polk	90	97	103	107
Sherman ^d	93 ^d	99 ^d	106 ^d	111 ^d
Tillamook	91	96	102	107
Tillamook special wind region ^a	125	135	145	145
Umatilla ^c	95 ^c	102 ^c	109 ^c	113 ^c
Union	96	102	109	113
Wallowa	97	103	110	115
Wasco ^d	93 ^d	99 ^d	106 ^d	110 ^d
Wasco special wind region ^a	100	110	115	115
Washington	91	97	103	107
Wheeler	94	100	107	111
Yamhill	91	97	103	107

For SI: 1 mile per hour = 0.45 m/s.

a. Refer to Figure 1609.3 for mapped special wind regions.

b. The basic design wind speed for buildings and structures in this region with full exposure (wind exposure category D) to Ocean winds shall be 125 mph for Risk Category I, 135 mph for Risk Category II, and 145 mph for Risk Categories III and IV.

c. The basic design wind speed for buildings and structures in this region with full exposure (wind exposure category D) to Columbia River Gorge winds shall be 125 mph for Risk Category I, 135 mph for Risk Category II, and 145 mph for Risk Categories III and IV.

d. The basic design wind speed for buildings and structures in this region with full exposure (wind exposure category D) to Columbia River Gorge winds shall be 115 mph for Risk Category I, 120 mph for Risk Category II, and 130 mph for Risk Categories III and IV.

OSSC Figure
1609.3

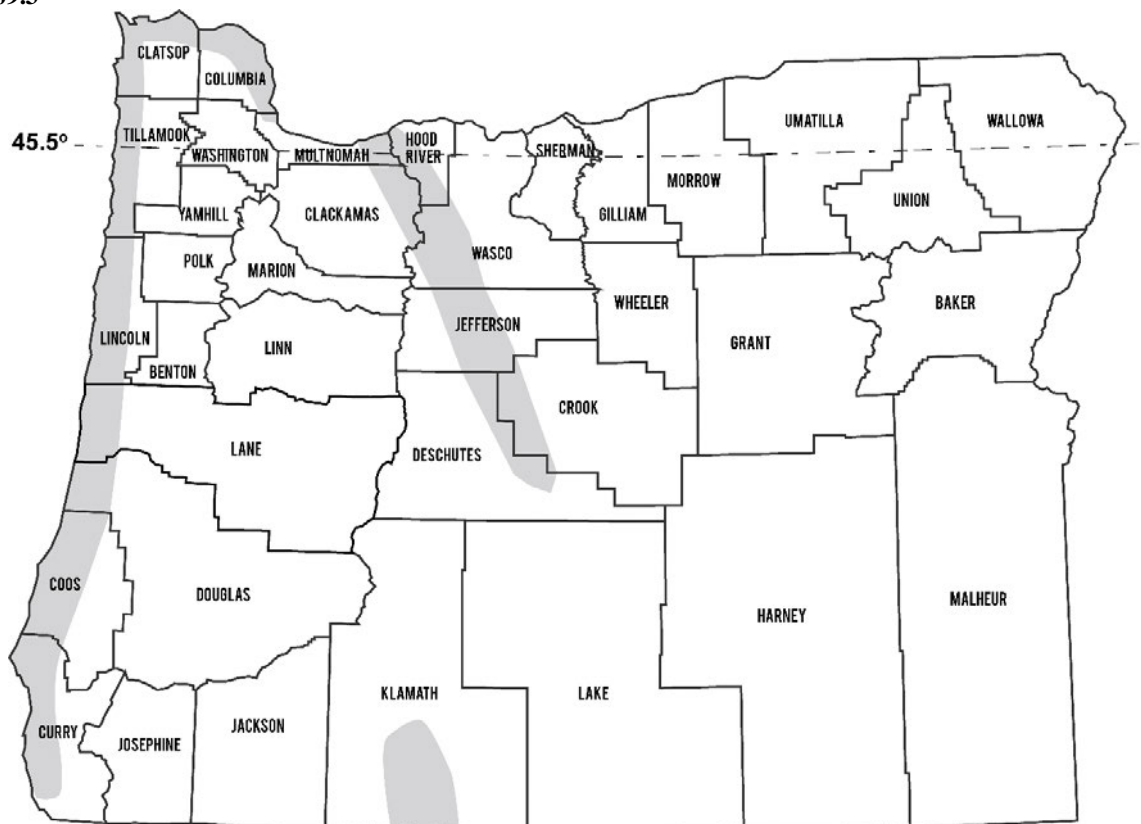


FIGURE 1609.3
OREGON SPECIAL WIND REGIONS^{a,b}

- a. Sites on the periphery of the identified special wind regions shall be verified using <https://hazards.atcouncil.org>.
- b. Basic design wind speeds shall be obtained from Table 1609.3; see Notes b, c and d for buildings and structures with full exposure (wind exposure category D) to Ocean or Columbia River Gorge winds.

IBC 1609.4.2 **1609.4.2 Surface roughness categories.** A ground surface roughness shall be established in accordance with ASCE 7.

(The rest of 1609.4.2 is not adopted)

IBC 1609.4.3 **1609.4.3 Exposure categories.** An exposure category shall be determined in accordance with ASCE 7.

(The rest of 1609.4.3 is not adopted)

Section 1610 Soil Loads and Hydrostatic Pressure

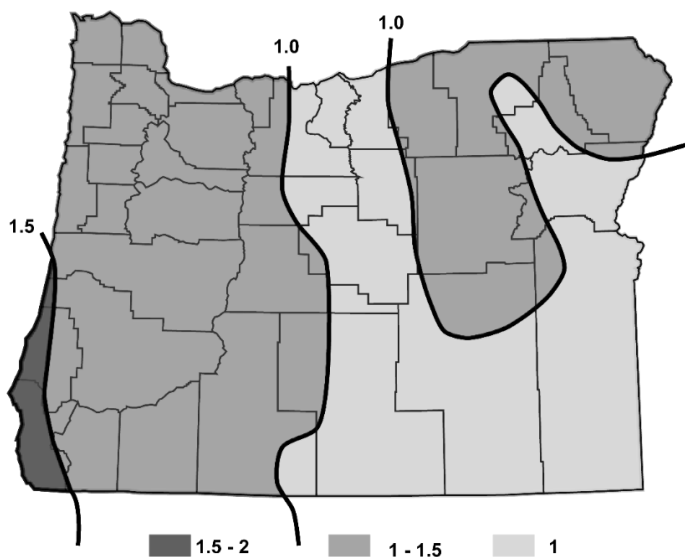
IBC 1610.1 **1610.1 Lateral pressures.** Foundation walls and retaining walls shall be designed to resist lateral soil *loads* from adjacent soil. Soil *loads* specified in Table 1610.1 shall be used as the minimum design lateral soil *loads* unless determined otherwise by a geotechnical investigation in accordance with Section 1803. Foundation walls and other walls in which horizontal movement is restricted at the top shall be designed for at-rest pressure. Retaining walls free to move and rotate at the top shall be permitted to be designed for active pressure. Lateral pressure from surcharge *loads* shall be added to the lateral soil *load*. Lateral pressure shall be increased if expansive soils are present at the site or the retaining wall will support an ascending backfill slope. *(The rest of 1610.1 remains unchanged)*

Section 1611 Rain Loads

IBC 1611.1 **1611.1 Design rain loads.** Each portion of a roof shall be designed to sustain the *load* of rainwater as per the requirements of Chapter 8 of ASCE 7. The design rainfall shall be based on the 100-year 15-minute duration event, ~~or on other rainfall rates determined from approved local weather data.~~ Alternatively, a design rainfall of twice the 100-year hourly rainfall rate indicated in Figures 1611.1(1) through 1611.1(5) shall be permitted.
(The rest of 1611.1 remains unchanged)

IBC Figures 1611.1	Figure 1611.1(1) 100-Year, 1-hour rainfall (inches) Western United States	<i>(Not adopted)</i>
	Figure 1611.1(2) 100-Year, 1-hour rainfall (inches) Central United States	<i>(Not adopted)</i>
	Figure 1611.1(3) 100-Year, 1-hour rainfall (inches) Eastern United States	<i>(Not adopted)</i>
	Figure 1611.1(4) 100-Year, 1-hour rainfall (inches) Alaska	<i>(Not adopted)</i>
	Figure 1611.1(5) 100-Year, 1-hour rainfall (inches) Hawaii	<i>(Not adopted)</i>

OSSC Figure 1611.1



[For SI: 1 inch = 25.4 mm.](#)
[Source: National Weather Service, National Oceanic and Atmospheric Administration, Washington, DC.](#)

FIGURE 1611.1
100-YEAR, 1-HOUR RAINFALL (INCHES) OREGON

Section 1612 Flood Loads

IBC 1612.1 **1612.1 General.** Within *flood hazard areas* as established in Section 1612.3, all new construction of buildings, ~~structures and portions of buildings~~ and structures, including *substantial improvement* and restoration of *substantial damage* to buildings and structures, shall be designed and constructed to resist the effects of flood hazards and *flood loads*. For buildings that are located in more than one *flood hazard area*, ~~as established by the flood plain administrator,~~ the provisions associated with the most restrictive *flood hazard area* shall apply.

IBC 1612.3 **1612.3 Establishment of flood hazard areas.** Where the local governing authority has adopted a flood hazard map and supporting data, the structure design and construction shall be in conformance with Section 1612.4.

~~To establish *flood hazard areas*, the applicable governing authority shall adopt a flood hazard map and supporting data. The flood hazard map shall include, at a minimum, areas of special flood hazard as identified by the Federal Emergency Management Agency in an engineering report entitled "The Flood Insurance Study for [INSERT NAME OF JURISDICTION]," dated [INSERT DATE OF ISSUANCE], as amended or revised with the accompanying Flood Insurance Rate Map (FIRM) and Flood Boundary and Floodway Map (FBFM) and related supporting data along with any revisions thereto. The adopted flood hazard map and supporting data are hereby adopted by reference and declared to be part of this section.~~

IBC 1612.3.1	1612.3.1 Design flood elevations.	<i>Not adopted</i>
IBC 1612.3.2	1612.3.2 Determination of impacts.	<i>Not adopted</i>
IBC 1612.4	<p>1612.4 Flood hazard documentation. The following documentation shall be prepared and sealed by a <i>registered design professional</i> and submitted to the <i>building official</i>:</p> <ol style="list-style-type: none"> 1. For construction in <i>flood hazard areas</i> other than <i>coastal high hazard areas</i> or <i>coastal A zones</i> <u>as established by the flood plain administrator</u>: <i>(Item 1.1. – 1.3 remain unchanged)</i> 2. For construction in <i>coastal high hazard areas</i> and <i>coastal A zones</i> <u>as established by the flood plain administrator</u>: <i>(Item 2.1. – 2.4 remain unchanged)</i> 	

Section 1613 Earthquake Loads

IBC 1613.1	<p>1613.1 Scope. Every structure, and portion thereof, including nonstructural components that are permanently attached to structures and their supports and attachments, shall be designed and constructed to resist the effects of earthquake motions in accordance with Chapters 11, 12, 13, 15, 17 and 18 of ASCE 7 <u>as modified by Section 1613.4</u>, as applicable. The <i>seismic design category</i> for a structure is permitted to be determined in accordance with Section 1613 or ASCE 7. <i>(Exception 1-5 remain unchanged)</i></p>																					
OSSC 1613.1.1	<p><u>1613.1.1 Suspended acoustical tile or lay-in panel ceilings.</u> <u>Suspended acoustical tile or lay-in panel ceilings in structures assigned to <i>Seismic Design Category C, D, E, or F</i> shall meet the prescriptive design provisions of ASCE 7 Section 13.5.6.2 unless designed in accordance with ASCE 7 Section 13.5.6.3 or seismically qualified in accordance with ASCE 7 Section 13.2.5 or 13.2.6.</u></p> <p><u>Exception: Suspended acoustical tile or lay-in panel ceiling areas less than or equal to 144 square feet (13.4 m²) enclosed by walls or soffits, provided that the walls or soffits are laterally braced to the structure above.</u></p>																					
IBC 1613.2.1	<p>1613.2.1 Mapped acceleration parameters. The parameters S_S and S_1, as illustrated in shall be determined from the 0.2 and 1 second spectral response accelerations shown on Figures 1613.2.1(1) and 1613.2.1(2) through 1613.2.1(10), shall be determined using the <u>Applied Technology Council (ATC) Hazards by Location Tool at Hazards.atcouncil.org</u>, with ASCE 7-16 selected as the “Reference Document.” Where S_1 is less than or equal to 0.04 and S_S is less than or equal to 0.15, the structure is permitted to be assigned <i>Seismic Design Category A</i>.</p> <table border="0" style="width: 100%;"> <tr> <td style="width: 80%;">Figure 1613.2.1(1) Risk-targeted ... (MCER) ... United States of 0.2-second ...</td> <td style="text-align: right;"><i>(Not adopted)</i></td> </tr> <tr> <td>Figure 1613.2.1(2) Risk-targeted ... (MCER) ... United States of 0.2-second ...</td> <td style="text-align: right;"><i>(Not adopted)</i></td> </tr> <tr> <td>Figure 1613.2.1(3) Risk-targeted ... (MCER) ... United States of 1-second ...</td> <td style="text-align: right;"><i>(Not adopted)</i></td> </tr> <tr> <td>Figure 1613.2.1(4) Risk-targeted ... (MCER) ... United States of 1-second ...</td> <td style="text-align: right;"><i>(Not adopted)</i></td> </tr> <tr> <td>Figure 1613.2.1(5) Risk-targeted ... (MCER) ... Hawaii of 0.2 and 1-second ...</td> <td style="text-align: right;"><i>(Not adopted)</i></td> </tr> <tr> <td>Figure 1613.2.1(6) Risk-targeted ... (MCER) ... Alaska of 0.2-second ...</td> <td style="text-align: right;"><i>(Not adopted)</i></td> </tr> <tr> <td>Figure 1613.2.1(7) Risk-targeted ... (MCER) ... Alaska of 1.0-second ...</td> <td style="text-align: right;"><i>(Not adopted)</i></td> </tr> <tr> <td>Figure 1613.2.1(8) Risk-targeted ... (MCER) ... Puerto Rico and the US Virgin ...</td> <td style="text-align: right;"><i>(Not adopted)</i></td> </tr> <tr> <td>Figure 1613.2.1(9) risk-targeted ... (MCER) ... Guam /Northern Mariana Islands ...</td> <td style="text-align: right;"><i>(Not adopted)</i></td> </tr> <tr> <td>Figure 1613.2.1(10) Risk-targeted ... (MCER) ... American Samoa ...</td> <td style="text-align: right;"><i>(Not adopted)</i></td> </tr> </table>		Figure 1613.2.1(1) Risk-targeted ... (MCER) ... United States of 0.2-second ...	<i>(Not adopted)</i>	Figure 1613.2.1(2) Risk-targeted ... (MCER) ... United States of 0.2-second ...	<i>(Not adopted)</i>	Figure 1613.2.1(3) Risk-targeted ... (MCER) ... United States of 1-second ...	<i>(Not adopted)</i>	Figure 1613.2.1(4) Risk-targeted ... (MCER) ... United States of 1-second ...	<i>(Not adopted)</i>	Figure 1613.2.1(5) Risk-targeted ... (MCER) ... Hawaii of 0.2 and 1-second ...	<i>(Not adopted)</i>	Figure 1613.2.1(6) Risk-targeted ... (MCER) ... Alaska of 0.2-second ...	<i>(Not adopted)</i>	Figure 1613.2.1(7) Risk-targeted ... (MCER) ... Alaska of 1.0-second ...	<i>(Not adopted)</i>	Figure 1613.2.1(8) Risk-targeted ... (MCER) ... Puerto Rico and the US Virgin ...	<i>(Not adopted)</i>	Figure 1613.2.1(9) risk-targeted ... (MCER) ... Guam /Northern Mariana Islands ...	<i>(Not adopted)</i>	Figure 1613.2.1(10) Risk-targeted ... (MCER) ... American Samoa ...	<i>(Not adopted)</i>
Figure 1613.2.1(1) Risk-targeted ... (MCER) ... United States of 0.2-second ...	<i>(Not adopted)</i>																					
Figure 1613.2.1(2) Risk-targeted ... (MCER) ... United States of 0.2-second ...	<i>(Not adopted)</i>																					
Figure 1613.2.1(3) Risk-targeted ... (MCER) ... United States of 1-second ...	<i>(Not adopted)</i>																					
Figure 1613.2.1(4) Risk-targeted ... (MCER) ... United States of 1-second ...	<i>(Not adopted)</i>																					
Figure 1613.2.1(5) Risk-targeted ... (MCER) ... Hawaii of 0.2 and 1-second ...	<i>(Not adopted)</i>																					
Figure 1613.2.1(6) Risk-targeted ... (MCER) ... Alaska of 0.2-second ...	<i>(Not adopted)</i>																					
Figure 1613.2.1(7) Risk-targeted ... (MCER) ... Alaska of 1.0-second ...	<i>(Not adopted)</i>																					
Figure 1613.2.1(8) Risk-targeted ... (MCER) ... Puerto Rico and the US Virgin ...	<i>(Not adopted)</i>																					
Figure 1613.2.1(9) risk-targeted ... (MCER) ... Guam /Northern Mariana Islands ...	<i>(Not adopted)</i>																					
Figure 1613.2.1(10) Risk-targeted ... (MCER) ... American Samoa ...	<i>(Not adopted)</i>																					
OSSC 1613.3	<p><u>1613.3 Photovoltaic panel systems.</u></p> <p>IBC 1613.3 <i>(Renumbered to 1613.3.1)</i></p> <p><u>1613.3.2 Rigidly attached photovoltaic panel systems.</u> <u>The mass of nonballasted photovoltaic panel systems shall be considered in the seismic design of the supporting structure.</u></p>																					

OSSC 1613.4

1613.3.3 Solar-ready roofs. Where roofs are required to be provided with a *solar-ready zone*, a collateral *dead load* shall be included in the seismic design of the building in accordance with Section 3111.4.

1613.4 Modifications to ASCE 7. The text of ASCE 7 shall be modified as indicated in Sections 1613.4.1 through 1613.4.15.

1613.4.1 ASCE 7, Section 12.2.3.2, Item e. Modify ASCE 7, Section 12.2.3.2, *Two-Stage Analysis Procedure*, Item e to read as follows:

- e. The upper portion is analyzed with the equivalent lateral force or modal response spectrum procedure, and the lower portion is analyzed with the equivalent lateral force procedure. Compliance with Table 12.6-1 shall be based on the height of each portion of the structure analyzed independently.

1613.4.2 ASCE 7, Section 13.1.4, Items 5 and 6. Modify ASCE 7, Section 13.1.4, *Exemptions*, Items 5 and 6 to read as follows:

- 5. Mechanical and electrical components in *Seismic Design Category C* provided that either
 - a. The component Importance factor, I_p , is equal to 1.0 and the component is positively attached to the structure; or
 - b. The component weighs 75 pounds (333N) or less or, in the case of a distribution system, 5 lb/ft (73 N/m) or less.
- 6. Discrete mechanical and electrical components in *Seismic Design Categories D, E and F* that are positively attached to the structure, provided that either
 - a. The component weighs 400 pounds (1,779 N) or less, the center of mass is located 4 feet or less above the adjacent floor or roof level, flexible connections are provided between the component and associated ductwork, piping, and conduit, and the component Importance Factor, I_p , is equal to 1.0; or
 - b. The component weighs 75 pounds (333 N) or less or, in the case of a distribution system, 5 lb/ft (73 N/m) or less;

1613.4.3 ASCE 7, Table 12.2-1, G.2 and footnote q. Modify ASCE 7, Table 12.2-1, *Design Coefficients and Factors for Seismic Force-Resisting Systems*, Item G.2 and add footnote q as follows:

2. Steel ordinary cantilever column systems	14.1	1 ¹ / ₄	1 ¹ / ₄	1 ¹ / ₄	35	35	NP ^a	NP ^a	NP ^a
---	------	-------------------------------	-------------------------------	-------------------------------	----	----	-----------------	-----------------	-----------------

- q. Single-story steel ordinary cantilever column systems in structures assigned to *Seismic Design Category D, E or F* are permitted in penthouse structures not exceeding 20 feet (6096 mm) in height and in single-story buildings up to a structural height, h_n , of 35 feet (10 668 mm), provided that the total effective seismic weight tributary to the roof, including the weight of walls, does not exceed 20 psf (0.96 kN/m²). The weight of the wall included in the 20 psf (0.96 kN/m²) previously noted shall be the seismic weight of the wall tributary to the roof, divided by the roof area.

1613.4.4 ASCE 7, Table 12.2-1 footnote j. Modify ASCE 7, Table 12.2-1, *Design Coefficients and Factors for Seismic Force-Resisting Systems*, footnote j to read as follows:

- j. Steel ordinary concentrically braced frames are permitted in penthouses not exceeding 20 feet (6096 mm) in height and in single-story buildings up to a structural height, h_n , of 60 feet (18 288 mm), provided that the total effective seismic weight tributary to the roof, including the weight of walls, does not exceed 20 psf (0.96 kN/m²). The weight of the wall included in the 20 psf (0.96 kN/m²) previously noted shall be the seismic weight of the wall tributary to the roof, divided by the roof area. In addition, the weight of the exterior wall more than 35 feet (10 668 mm) above the base and tributary to the braced frame shall not exceed 20 psf (0.96 kN/m²).

1613.4.5 ASCE 7, Section 12.2.5.4. Modify ASCE 7, Section 12.2.5.4, *Increased Structural Height Limit for Steel Eccentrically Braced Frames, Steel Special Concentrically Braced Frames, Steel Buckling-Restrained Braced Frames, Steel Special Plate Shear Walls, and Special Reinforced Concrete Shear Walls*, by adding the following exception:

Exception: For application of the provisions in this section only, stories where the story drift ratio measured at the extreme corners of the diaphragm does not exceed 0.25 percent need not be considered in the determination of horizontal structural irregularity Type 1b in Table 12.3-1.

1613.4.6 ASCE 7, Section 12.2.5.6. Modify ASCE 7, Section 12.2.5.6, *Steel Ordinary Moment Frames*.

1613.4.6.1 ASCE 7, Section 12.2.5.6.1, Item a. Modify ASCE 7, Section 12.2.5.6.1, *Seismic Design Category D or E*, Item a to read as follows:

a. Single-story steel ordinary moment frames in structures assigned to *Seismic Design Category D* or *E* are permitted in penthouses not exceeding 20 feet (6096 mm) in height and in buildings up to a structural height, h_n , of 65 feet (19 812 mm), provided that the total effective seismic weight tributary to the roof, including the weight of walls, does not exceed 20 psf (0.96 kN/m²). The weight of the wall included in the 20 psf (0.96 kN/m²) previously noted shall be the seismic weight of the wall tributary to the roof, divided by the roof area. In addition, the weight of the exterior wall more than 35 feet (10 668 mm) above the base and tributary to the moment frame shall not exceed 20 psf (0.96 kN/m²).

Exception: Single-story structures with steel ordinary moment frames whose purpose is to enclose equipment or machinery (including cranes) and whose occupants are engaged in maintenance or monitoring of that equipment, machinery, or their associated processes shall be permitted to be of unlimited height, provided that the total effective seismic weight tributary to the roof, including contribution from walls, equipment or machinery, does not exceed 20 psf (0.96 kN/m²). In addition, the dead load of the exterior wall system, including exterior columns more than 35 feet (10 668 mm) above the base, shall not exceed 20 psf (0.96 kN/m²). For determining compliance with effective seismic weight limitations of the roof and exterior walls, equipment and machinery, including cranes, not self-supporting for all loads, shall be treated as fully tributary to either the roof or adjacent exterior wall (but not both) where located in an exterior bay, or as fully tributary to the adjacent roof where located in an interior bay. The tributary area used for weight distribution of equipment and machinery shall not exceed 600 square feet (56 m²).

1613.4.6.2 ASCE 7, Section 12.2.5.6.2. Modify ASCE 7, Section 12.2.5.6, *Seismic Design Category F*, to read as follows:

Single-story steel ordinary moment frames in structures assigned to *Seismic Design Category F* are permitted in penthouses not exceeding 20 feet (6096 mm) in height and in buildings up to a structural height, h_n , of 65 feet (19 812 mm), provided that the total effective seismic weight tributary to the roof, including the weight of walls, does not exceed 20 psf (0.96kN/m²). The weight of the wall included in the 20 psf (0.96 kN/ m²) previously noted shall be the seismic weight of the wall tributary to the roof, divided by the roof area. In addition, the weight of the exterior wall more than 35 feet (10 668 mm) above the base and tributary to the moment frame shall not exceed 20 psf (0.96 kN/m²).

1613.4.7 ASCE 7, Section 12.2.5.7. Modify ASCE 7, Section 12.2.5.7, *Steel Intermediate Moment Frames*, according to Sections 1613.5.7.1 through 1613.5.7.3.

1613.4.7.1 ASCE 7, Section 12.2.5.7.1, Item a. Modify ASCE 7, Section 12.2.5.7.1, *Seismic Design Category D*, Item a, to read as follows:

a. Single-story steel intermediate moment frames in structures assigned to *Seismic Design Category D* are permitted in penthouses not exceeding 20 feet (6096 mm) in height and in buildings up to a structural height, h_n , of 65 feet (19 812 mm), provided that the total effective seismic weight tributary to the roof, including the weight of walls, does not exceed 20 psf (0.96 kN/m²). The weight of the wall included in the 20 psf (0.96 kN/m²) previously noted shall be the seismic weight of the wall tributary to the roof, divided by

the roof area. In addition, the weight of the exterior wall more than 35 feet (10 668 mm) above the base and tributary to the moment frame shall not exceed 20 psf (0.96 kN/m²).

Exception: Single-story structures with steel intermediate moment frames whose purpose is to enclose equipment or machinery (including cranes) and whose occupants are engaged in maintenance or monitoring of that equipment, machinery or their associated processes, shall be permitted to be of unlimited height, provided that the total effective seismic weight tributary to the roof, including contribution from walls, equipment or machinery, does not exceed 20 psf (0.96 kN/m²). In addition, the dead load of the exterior wall system, including exterior columns more than 35 feet (10 668 mm) above the base, shall not exceed 20 psf (0.96 kN/m²). For determining compliance with effective seismic weight limitations of the roof and exterior walls, equipment and machinery, including cranes, not self-supporting for all loads, shall be treated as fully tributary to either the roof or adjacent exterior wall (but not both) where located in an exterior bay, or as fully tributary to the adjacent roof, where located in an interior bay. The tributary area used for weight distribution of equipment and machinery shall not exceed 600 square feet (56 m²).

1613.4.7.2 ASCE 7, Section 12.2.5.7.2, Item a. Modify ASCE 7, Section 12.2.5.7.2, *Seismic Design Category E*, Item a, to read as follows:

- a. Single-story steel intermediate moment frames in structures assigned to *Seismic Design Category E* are permitted in penthouses not exceeding 20 feet (6096 mm) in height and in buildings up to a structural height, h_n , of 65 feet (19 812 mm), provided that the total effective seismic weight tributary to the roof, including the weight of walls, does not exceed 20 psf (0.96 kN/m²). The weight of the wall included in the 20 psf (0.96 kN/m²) previously noted shall be the seismic weight of the wall tributary to the roof, divided by the roof area. In addition, the weight of the exterior wall more than 35 feet (10 668 mm) above the base and tributary to the moment frame shall not exceed 20 psf (0.96 kN/m²).

Exception: Single-story structures with steel intermediate moment frames whose purpose is to enclose equipment or machinery (including cranes) and whose occupants are engaged in maintenance or monitoring of that equipment, machinery or their associated processes shall be permitted to be of unlimited height, provided that the total effective seismic weight tributary to the roof, including contribution from walls, equipment or machinery, does not exceed 20 psf (0.96 kN/m²). In addition, the dead load of the exterior wall system, including exterior columns more than 35 feet (10 668 mm) above the base, shall not exceed 20 psf (0.96 kN/m²). For determining compliance with effective seismic weight limitations of the roof and exterior walls, equipment and machinery, including cranes, not self-supporting for all loads, shall be treated as fully tributary to either the roof or adjacent exterior wall (but not both) where located in an exterior bay, or as fully tributary to the adjacent roof where located in an interior bay. The tributary area used for weight distribution of equipment and machinery shall not exceed 600 square feet (56 m²).

1613.4.7.3 ASCE 7, Section 12.2.5.7.3, Item a. Modify ASCE 7, Section 12.2.5.7.3, *Seismic Design Category F*, Item a, to read as follows:

- a. Single-story steel intermediate moment frames in structures assigned to *Seismic Design Category F* are permitted in penthouses not exceeding 20 feet (6096 mm) in height and in buildings up to a structural height, h_n , of 65 feet (19 812 mm), provided that the total effective seismic weight tributary to the roof, including the weight of walls, does not exceed 20 psf (0.96 kN/m²). The weight of the wall included in the 20 psf (0.96 kN/m²) previously noted shall be the seismic weight of the wall tributary to the roof, divided by the roof area. In addition, the weight of the exterior wall more than 35 feet (10 668 mm) above the base and tributary to the moment frame shall not exceed 20 psf (0.96 kN/m²).

1613.4.8 ASCE 7, Section 12.3.3.1. Modify ASCE 7, Section 12.3.3.1, *Prohibited Horizontal and Vertical Irregularities for Seismic Design Categories D through F*, by adding the following exception:

Exception: For application of the provisions in this section only, stories where the story drift ratio measured at the extreme corners of the diaphragm does not exceed 0.25 percent need not be considered in the determination of horizontal structural irregularity Type 1b in Table 12.3-1.

1613.4.9 ASCE 7, Section 12.3.3.3. Modify ASCE 7, Section 12.3.3.3, *Elements Supporting Discontinuous Walls or Frames*, to read as follows:

Structural elements and their connections supporting discontinuous walls or frames of structures that have horizontal irregularity Type 4 of Table 12.3-1 or vertical irregularity Type 4 of Table 12.3-2 shall be designed to resist the seismic load effects including overstrength of Section 12.4.3. The connections of discontinuous walls or frames to the supporting members shall be adequate to transmit the forces for which the discontinuous walls or frames were required to be designed.

1613.4.10 ASCE 7, Section 12.7.2, Item 1. Modify ASCE 7, Section 12.7.2, *Effective Seismic Weight*, Item 1, to read as follows:

1. In areas used for storage or in library stack rooms, a minimum of 25 percent of the floor live load shall be included.

Exceptions:

- a. Where the inclusion of storage loads or library stack loads adds not more than 5 percent to the effective seismic weight at that level, it need not be included in the effective seismic weight.
- b. Floor live load in public garages and open parking structures need not be included.

1613.4.11 ASCE 7, Section 12.14.8.1, Item 1. Modify ASCE 7, Section 12.14.8.1, *Seismic Base Shear*, Item 1, to read as follows:

1. In areas used for storage or in library stack rooms, a minimum of 25 percent of the floor live load shall be included.

Exceptions:

- a. Where the inclusion of storage loads or library stack loads adds not more than 5 percent to the effective seismic weight at that level, it need not be included in the effective seismic weight.
- b. Floor live load in public garages and open parking structures need not be included.

1613.4.12 ASCE 7, Section 13.5.6.2.2, Item c. Modify ASCE 7, Section 13.5.6.2.2, *Seismic Design Categories D through F*, by adding an Item c to read as follows:

- c. Ceiling areas of 1,000 square feet (93 m²) or less shall be exempt from the lateral force bracing requirements of ASTM E580, Section 5.2.8.

1613.4.13 ASCE 7, Section 15.4.3. Modify ASCE 7, Section 15.4.3, *Loads*, to read as follows:

The seismic effective weight, W , for nonbuilding structures shall include the dead load and other loads as defined for structures in Section 12.7.2. For purposes of calculating design seismic forces in nonbuilding structures, W also shall include all normal operating contents for items such as tanks, vessels, bins, hoppers and the contents of piping. W shall include 20 percent of snow or ice loads where the flat roof snow load, P_f , or weight of ice, D_i , exceeds 30 psf (1.44 kN/m²), regardless of actual roof or top of structure slope.

1613.4.14 ASCE 7, Section 21.3. Modify ASCE 7, Section 21.3, *Design Response Spectrum*, to read as follows:

The design spectral response acceleration at any period shall be determined from Equation (21.3-1):

$$S_a = \frac{2}{3} S_{aM} \quad (21.3-1)$$

where S_{aM} is the MCE spectral response acceleration obtained from Section 21.1 or 21.2.

The design spectral response acceleration at any period shall not be taken as less than 80 percent of S_a determined in accordance with Section 11.4.6, where F_a and F_v are determined as follows:

- (i) For Site Classes A, B, and C: F_a and F_v are determined using Tables 11.4-1 and 11.4-2, respectively;

(ii) For Site Class D: F_a is determined using Table 11.4-1, and F_v is taken as 2.4 for $S_1 < 0.2$ or 2.5 for $S_1 \geq 0.2$; and

(iii) For Site Class E: F_a is determined using Table 11.4-1 for $S_s < 1.0$ or taken as 1.0 for $S_s \geq 1.0$, and F_v is taken as 4.2 for $S_1 < 0.1$ or 4.0 for $S_1 > 0.1$.

Exception: For Site Classes D and E, the value of F_v may be determined using straight-line interpolation between the value determined from ASCE 7, Section 21.3, without the provisions of this exception and the value determined from Table 1613.2.3(2) in the *Building Code*, based on the relative hazard contribution from the Cascadia Subduction Zone interface sources. The values of F_v from ASCE 7, Section 21.3, without the provisions of this exception and Table 1613.2.3(2) in the *Building Code*, shall be associated with a relative hazard contribution from the Cascadia Subduction Zone interface sources of zero (0) percent and 100 percent, respectively. The relative hazard contribution shall be determined using the USGS Unified Hazard Tool and the 2014 National Seismic Hazard Map model data for the 2-percent probability of occurrence in 50-year hazard, a spectral period of one (1) second and the soil site class for the site. All Cascadia Subduction Zone interface sources shall be summed and divided by the sum of the deaggregated hazards which contribute a minimum of 1 percent to the hazard. A site-specific PSHA at spectral periods greater than 1 second that are consistent with the first modal period of the structure can substitute the USGS Unified Hazard Tool when geotechnical peer review is included in the project.

For sites classified as Site Class F requiring site-specific analysis in accordance with Section 11.4.7, the design spectral response acceleration at any period shall not be less than 80 percent of S_a determined for Site Class E in accordance with Section 11.4.5.

Exception: Where a different site class can be justified using the site-specific classification procedures in accordance with Section 20.3.3, a lower limit of 80 percent of S_a for the justified site class shall be permitted to be used.

1613.4.15 ASCE 7, Section 13.4.5, Exceptions. Modify ASCE 7, Section 13.4.5, *Power-Actuated Fasteners*, Exceptions to read as follows:

Exceptions:

1. Power-actuated fasteners in concrete used for support of acoustical tile or lay-in panel suspended ceiling applications and distribution systems where the service load on any individual fastener does not exceed 90 pounds (400 N); and
2. Power-actuated fasteners in steel where the service load on any individual fastener does not exceed 250 pounds (1112 N).

1613.5 Earthquake recording instrumentation. In *Seismic Design Category D, E or F*, every new building over six stories above grade in height with an aggregate floor area of 60,000 square feet (5574m²) or more, and every building over 10 stories in height regardless of the floor area, shall be provided with an approved system with not less than three approved recording accelerographs. The accelerographs shall be interconnected for common start and common timing.

Exception: In lieu of installing the earthquake recording instrumentation as outlined in this section, the applicant is permitted to make a deposit of an equivalent cost to the Earthquake Recording Instrument Fund in the Oregon Department of Geology and Mineral Industries (DOGAMI). Proof of this deposit shall be provided to the *building official*.

1613.5.1 Location. The instruments shall be located in the lowest floor level, midportion, and near the top of the building. (Upper-level instruments shall be positioned to record earthquake motions at mutually orthogonal directions; for example, N-S and E-W directions.) Each instrument shall be located so that access is maintained at all times and is unobstructed by room contents. A sign stating "MAINTAIN CLEAR ACCESS TO THIS INSTRUMENT" shall be posted in a conspicuous location. Agents of DOGAMI are considered deputies of the *building official* with jurisdiction and shall have access to accelerographs. If access to accelerographs is denied, DOGAMI shall have recourse to remedies provided by law.

1613.5.2 Maintenance. Maintenance and service of the instruments shall be provided by the owner of the building, subject to the approval of the *building official* and DOGAMI. Data produced by the instruments shall be made available to the *building official* on request.

1613.5.3 Records. Noninterpretive seismic data recorded by the accelerographs shall be filed with DOGAMI. Copies of individual records shall be made available by DOGAMI to the public on request and payment of an appropriate fee.

Note: Where strong motion accelerographs are required and installed in a building, the *building official* shall notify DOGAMI and indicate the address and location of the accelerographs within the building. DOGAMI can be reached at: 800 NE Oregon St., Suite 965, Portland, OR 97232.

Section 1615 Tsunami Loads

IBC 1615.1 **1615.1 General.** The design and construction of *Tsunami Risk Category III and IV buildings and other structures located in the Tsunami Design Zones defined in the Tsunami Design Geodatabase* shall be in accordance with Chapter 6 of ASCE 7, except as modified by [Section 1615.2](#) ~~this code~~.

OSSC 1615.2 **1615.2 Modifications to ASCE 7, Chapter 6.** The text of Chapter 6 of ASCE 7 shall be modified as indicated in Sections 1615.2.1 through 1615.2.11.

1615.2.1 ASCE 7 Section 6.1.1. Modify ASCE 7, Section 6.1.1, *Scope*, to read as follows: *Tsunami Risk Category III and IV buildings and other structures, as defined in Chapter 2 of the Building Code, located within the Tsunami Design Zone shall be designed for the effects of Maximum Considered Tsunami, including hydrostatic and hydrodynamic forces, waterborne debris accumulation and impact loads, subsidence, and scour effects in accordance with this chapter.*

Tsunami Design Zone shall be determined using the ASCE Tsunami Design Geodatabase of geocoded reference points shown in Figure 6.1-1. The ASCE Tsunami Design Geodatabase of geocoded reference points of Runup and associated Inundation Limits of the Tsunami Design Zone is available at [asce7tsunami.online].

Designated nonstructural components and systems associated with Tsunami Risk Category IV buildings and other structures subject to this chapter shall be located above, protected from, or otherwise designed for inundation in accordance with Section 6.15 so that they are able to provide their essential functions immediately following the Maximum Considered Tsunami event.

1615.2.2 ASCE 7 Section 6.2. Modification to ASCE 7, Section 6.2, *Definitions*.

1615.2.2.1. The following terms are deleted:

~~**CRITICAL EQUIPMENT OR CRITICAL SYSTEMS.**~~

~~**CRITICAL FACILITY.**~~

~~**NONBUILDING CRITICAL FACILITY STRUCTURE.**~~

~~**TSUNAMI VERTICAL EVACUATION REFUGE STRUCTURE.**~~

1615.2.2.2. Modify the term *Tsunami Risk Category*, to read as follows:

TSUNAMI RISK CATEGORY. See definitions in Chapter 2 of the *Building Code*.

1615.2.3 ASCE 7 Section 6.4. ASCE 7, Section 6.4, *Tsunami Risk Categories*, is deleted.

1615.2.4 ASCE Section 6.5.1. Modify ASCE 7, Section 6.5.1, *Tsunami Risk Category II and III Buildings and Other Structures*, to read as follows:

6.5.1 Tsunami risk category III buildings and other structures. The Maximum Considered Tsunami inundation depth and tsunami flow velocity characteristics at a Tsunami Risk Category III building or other structure shall be determined by using the Energy Grade Line Analysis of Section 6.6 using the inundation limit and runup elevation of the Maximum Considered Tsunami given in Figure 6.1-1.

The site-specific Probabilistic Tsunami Hazard Analysis (PTHA) in Section 6.7 shall be permitted as an alternate to the Energy Grade Line Analysis. Site-specific velocities determined by PTHA shall be subject to the limitation in Section 6.7.6.8.

1615.2.5 ASCE Section 6.5.1.1. ASCE 7, Section 6.5.1.1, *Runup Evaluation for Areas Where No Map Values Are Given*, is deleted.

1615.2.6 ASCE Section 6.5.2. Modify the exception to ASCE 7, Section 6.5.2, *Tsunami Risk Category IV Buildings and Other Structures*, to read as follows:

Exception: A site-specific Probabilistic Tsunami Hazard Analysis need not be performed where the inundation depth resulting from the Energy Grade Line Analysis is determined to be less than 12 ft (3.66 m) at any point within the location of the *Tsunami Risk Category IV* structure.

1615.2.7 ASCE 7 Section 6.8.2. Modify ASCE 7, Section 6.8.2, *Performance of Tsunami Risk Category III Critical Facilities and Tsunami Risk Category IV Buildings and Other Structures*, to read as follows:

6.8.2 Performance of Tsunami Risk Category IV buildings and other structures. *Tsunami Risk Category IV* buildings and other structures located within the Tsunami Design Zone shall be designed in accordance with the following requirements.

1. The operational nonstructural components and equipment of the building necessary for essential functions and the elevation of the bottom of the lowest horizontal structural member at the level supporting such components and equipment shall be above the inundation elevation of the Maximum Considered Tsunami.
2. Structural components and connections in occupiable levels and foundations shall be designed in accordance with Immediate Occupancy Structural Performance criteria. Occupiable levels shall be permitted where the elevation equals or exceeds the Maximum Considered Tsunami inundation elevation.

1615.2.8 ASCE 7 Table 6.8-1. Modify ASCE 7, Table 6.8-1, *Tsunami Importance Factors for Hydrodynamic and Impact Loads*, to read as follows:

Table 6.8-1 Tsunami Important Factors for Hydrodynamic and Impact Loads

<u>Tsunami Risk Category</u>	<u>I_{su}</u>
<u>III</u>	<u>1.25</u>
<u>IV</u>	<u>1.25</u>

1615.2.9 ASCE 7 Section 6.11. Modify the last paragraph of ASCE 7, Section 6.11, *Debris Impact Loads*, to read as follows:

Tsunami Risk Category IV buildings and other structures determined to be in the hazard zone for strikes by ships and barge in excess of 88,000 lb (39,016 kg) Deadweight Tonnage (DWT), as determined by the procedure of Section 6.11.5, shall be designed for impact by these vessels in accordance with Section 6.11.7.

1615.2.10 ASCE 7 Section 6.11.7. Modify the first sentence of ASCE 7, Section 6.11.7, *Extraordinary Debris Impacts*, to read as follows:

Where the maximum inundation depth exceeds 12 feet (3.66 m), extraordinary debris impacts of the largest deadweight tonnage vessel with ballasted draft less than the inundation depth within the debris hazard region of piers and wharves defined in Section 6.11.5 shall be assumed to impact the perimeter of *Tsunami Risk Category IV* buildings and other structures anywhere from the base of the structure up to 1.3 times the inundation depth plus the height to the deck of the vessel.

1615.2.11 ASCE 7 Section 6.14. ASCE 7, Section 6.14, *Tsunami Vertical Evacuation Refuge Structures*, is deleted.

CHAPTER 17

SPECIAL INSPECTIONS AND TESTS

Section 1704 Special Inspections and Tests, Contractor Responsibility and Structural Observation

IBC 1704.2.5.1 **1704.2.5.1 Fabricator approval.** *Special inspections* during fabrication are not required where the work is done on the premises of a fabricator *approved* to perform such work without *special inspection*. Approval shall be based on review of the fabricator's written fabrication procedures and quality control manuals that provide a basis for control of materials and workmanship, with periodic auditing of fabrication and quality control practices by [a nationally recognized accrediting authority](#) ~~an approved agency or the building official~~. At completion of fabrication, the *approved fabricator* shall submit a *certificate of compliance* to the owner or the owner's authorized agent for submittal to the *building official* as specified in Section 1704.5 stating that the work was performed in accordance with the *approved construction documents*.

Section 1705 Required Special Inspections and Tests

IBC 1705.2 **1705.2 Steel construction.** The *special inspections* and nondestructive testing of steel construction in buildings, structures, and portions thereof shall be in accordance with this section [and Table 1705.2](#).

Exceptions:

1. *Special inspections* of the steel fabrication process shall not be required where the fabrication process for the entire building or structure does not include any welding, thermal cutting or heating operation of any kind. In such cases, the fabricator shall be required to submit a detailed procedure for material control that demonstrates the fabricator's ability to maintain suitable records and procedures such that, at any time during the fabrication process, the material specification and grade for the main stress-carrying elements are capable of being determined. Mill test reports shall be identifiable to the main stress-carrying elements where required by the *approved construction documents*.
2. [The special inspector need not be continuously present during welding of the following items, provided that the materials, welding procedures and qualifications of welders are verified prior to the start of the work; periodic inspections are made of the work in progress; and a visual inspection of all welds is made prior to completion or prior to shipment of shop welding:](#)
 - 2.1. [Single-pass fillet welds not exceeding \$\frac{5}{16}\$ inch \(7.9 mm\) in size.](#)
 - 2.2. [Floor and roof deck welding.](#)
 - 2.3. [Welded studs where not installed with an automatically timed stud welding machine in accordance with Section 7 of AWS D1.1.](#)
 - 2.4. [Welded sheet steel for cold-formed steel members.](#)
 - 2.5. [Welding of stairs and railing systems.](#)
3. [For welded studs installed with an automatically timed stud welding machine and in accordance with Section 7 of AWS D1.1, the special inspector need not be continuously present during installation of welded studs subject to the following provisions:](#)
 - 3.1. [The special inspector shall perform a visual inspection of all welded studs in accordance with Sections 7 and 7.8.1 of AWS D1.1. Visual inspection of welded studs installed with an automatically timed stud welding machine may take place either in the fabrication shop prior to completion or prior to shipment, or on-site prior to coverage.](#)
 - 3.2. [The fabricator shall submit a certificate of compliance to the building official stating that the work was performed in accordance with the approved construction documents.](#)

1705.2.1.1 Modifications to AISC 360, Chapter N. The following provisions in AISC 360, Chapter N, are not adopted:

1. Section N4, Item 2. *Quality Assurance Inspector Qualifications.*
2. Section N5, Item 2. *Quality Assurance.*
3. Section N5, Item 3. *Coordinated Inspection.*
4. Section N5, Item 4. *Inspection of Welding.*
5. Section N6. *Approved Fabricators and Erectors.*
6. Section N7. *Nonconforming Material and Workmanship.*

1705.2.1.2 High strength bolting. In addition to the quality assurance inspection requirements contained in AISC 360, Section N5, Item 6, *Inspection of High Strength Bolting*, the requirements of Table 1705.2 shall apply.

TABLE 1705.2
REQUIRED VERIFICATION AND INSPECTION OF STEEL CONSTRUCTION

VERIFICATION AND INSPECTION	CONTIN- UOUS	PER- IODIC	REFERENCED STANDARD ^a
1. Material verification of high-strength bolts, nuts and washers:			
a. Identification markings to conform to ASTM standards and specified in the approved construction documents.	—	X	AISC 360, Section A3.3 and applicable ASTM material standards
b. Manufacturer's certificate of compliance required.	—	X	—
2. Inspection of high-strength bolting:			
a. Snug-tight joints.	—	X	AISC 360, Section M2.5
b. Pretensioned and slip-critical joints using turn-of-nut with matchmarking, twist-off bolt or direct tension indicator methods of installation.	—	X	
c. Pretensioned and slip-critical joints using turn-of-nut without matchmarking or calibrated wrench methods of installation.	X	—	
3. Material verification of structural steel:			
a. For structural steel, identification markings to conform to AISC 360.	—	X	AISC 360, Section N2.1
b. For other steel, identification markings to conform to ASTM standards specified in the approved construction documents.	—	X	Applicable ASTM material standards
c. Manufacturer's certified test reports.	—	X	—
4. Material verification of cold-formed steel deck:			
a. Manufacturer's certified test reports.	—	X	—
5. Material verification of weld filler materials:			
a. Identification markings to conform to AWS specification in the approved construction documents.	—	X	AISC 360, Section A3.5 and applicable AWS A5 documents
b. Manufacturer's certificate of compliance required.	—	X	—
6. Inspection of welding:			
a. Structural steel and cold-formed steel deck:			
1) Complete and partial joint penetration groove welds.	X	—	AWS D1.1
2) Multi-pass fillet welds.	X	—	
3) Single-pass fillet welds $> \frac{5}{16}$ ".	X	—	
4) Plug and slot welds.	X	—	
5) Single-pass fillet welds $> \frac{5}{16}$ ".	—	X	
6) Floor and roof deck welds.	—	X	AWS D1.3
b. Reinforcing steel:			
1) Verification of weldability of reinforcing steel other than ASTM A706.	—	X	AWS D1.4, ACI 318 Section 26.6.4
2) Reinforcing steel resisting flexural and axial forces in intermediate and special moment frames, and boundary elements of special structural walls of concrete and shear reinforcement.	X	—	
3) Shear reinforcement.	X	—	
4) Other reinforcing steel.	—	X	
7. Inspection of steel frame joint details for compliance:			
a. Details such as bracing and stiffening.	—	X	—
b. Member location.	—	X	
c. Application of joint details at each connection.	—	X	

For SI: 1 inch = 25.4 mm.

- a. Where applicable, see also Section 1705.13, Special inspections for seismic resistance.

IBC 1705.3

1705.3 Concrete construction. *Special inspections* and tests of concrete construction shall be performed in accordance with this section and Table 1705.3.

Exceptions: *Special inspections* and tests shall not be required for:

(Exceptions 1 and 3 through 5 remain unchanged)

2. Continuous concrete footings supporting walls of buildings three stories or less above *grade plane* that are fully supported on earth or rock where:
 - 2.1. The footings support walls of *light-frame construction*; and either
 - 2.2. The footings are designed in accordance with Table 1809.7; or
 - 2.3. The structural design of the footing is based on a ~~specified~~-compressive strength, f'_c , not more than 2,500 pounds per square inch (psi) (17.2 MPa), regardless of the compressive strength specified in the *approved construction documents* or used in the footing construction.

**TABLE 1705.3
REQUIRED SPECIAL INSPECTIONS AND TESTS OF CONCRETE CONSTRUCTION**

TYPE	CONTINUOUS SPECIAL INSPECTION	PERIODIC SPECIAL INSPECTION	REFERENCED STANDARD ^a	IBC REFERENCE
3. Inspect anchors cast in concrete.	—	X	ACI 318: 17.8.2 <u>17.2.5</u>	—
4. Inspect anchors post-installed in hardened concrete members. ^b				
a. Adhesive anchors installed in horizontally or upwardly inclined orientations to resist sustained tension loads.	X	—	ACI 318: 17.8.2.4 <u>17.2.5</u>	—
b. Mechanical anchors and adhesive anchors not defined in 4. ^a	—	X	ACI 318: 17.8.2 <u>17.2.5</u>	—

For SI: 1 inch = 25.4 mm.

- a. Where applicable, see Section 1705.13.
- b. Specific requirements for special inspection shall be included in the research report for the anchor issued by an approved source in accordance with ~~17.8.2-17.2.5~~ in ACI 318, or other qualification procedures. Where specific requirements are not provided, special inspection requirements shall be specified by the registered design professional and shall be approved by the building official prior to the commencement of the work.

IBC 1705.10

1705.10 Structural integrity of deep foundation elements. Whenever there is a ~~reasonable doubt as to~~ documented concern submitted to the municipality regarding the structural integrity of a *deep foundation* element, or where notification of such concern is provided by the registered design professional in responsible charge, the building official is authorized to require an engineering assessment ~~shall be required~~. The engineering assessment shall include tests for defects performed in accordance with ASTM D4945, ASTM D5882, ASTM D6760 or ASTM D7949, or other *approved method*.

IBC 1705.13.1.1

1705.13.1.1 Seismic force-resisting systems. *Special inspections* of structural steel in the *seismic force-resisting systems* in buildings and structures assigned to *Seismic Design Category* B, C, D, E or F shall be performed in accordance with Section 1705.2 and the quality assurance requirements of AISC 341, Chapter J. *(The exceptions remain unchanged)*

IBC 1705.13.1.2

1705.13.1.2 Structural steel elements. *Special inspections* of *structural steel elements* in the *seismic force-resisting systems* of buildings and structures assigned to *Seismic Design Category* B, C, D, E or F other than those covered in Section 1705.13.1.1, including struts, *collectors*, chords and foundation elements, shall be performed in accordance with Section 1705.2 and the quality assurance requirements of AISC 341, Chapter J. *(The exceptions remain unchanged)*

IBC 1705.13.5

1705.13.5 Architectural components. *Periodic special inspection* is required for the erection and fastening of exterior cladding, interior and exterior nonbearing walls and interior and exterior *vener* in structures assigned to *Seismic Design Category* D, E or F.

Exception: *Periodic special inspection* is not required for the following:

1. Exterior cladding, interior and exterior nonbearing walls and interior and exterior *vener* 30 feet (9144 mm) or less in height above grade or walking surface.
2. Exterior cladding and interior and exterior *vener* weighing 5 psf (0.24 kN/m²) or less.
3. Interior and exterior nonbearing walls ~~assemblies~~ weighing 15 psf (0.72 kN/m²) or less.

- IBC 1705.14.2** **1705.14.2 Nonstructural components.** For structures assigned to *Seismic Design Category B, C, D, E or F*, where the requirements of Section 13.2.1 of ASCE 7 for nonstructural components, supports or attachments are met by seismic qualification as specified in Item 2 therein, the *registered design professional* shall specify on the *approved construction documents* the requirements for seismic qualification by analysis, testing or experience data. Where seismic qualification is met by testing or experience data, certificates of compliance for the seismic qualification prepared by or reviewed and accepted by a registered design professional shall be submitted to the *building official* as specified in Section 1704.5.
- IBC 1705.14.3** **1705.14.3 Designated seismic systems.** ~~Where Risk Category III or IV-For~~ structures located in assigned to Seismic Design Category C, D, E or F have mechanical, electrical or plumbing components of the and with designated seismic systems that are subject to the requirements of Section 13.2.1 or 13.2.2 of ASCE 7 and meet the requirements for seismic qualification as specified in Item 2 of Section 13.2.1 therein-certification, the *registered design professional* shall specify on the *approved construction documents* the requirements to be met for seismic qualification by analysis, testing or experience data as specified therein. Certificates of compliance for seismic qualification, prepared by or reviewed and accepted by a registered design professional and demonstrating fulfillment of the seismic certification requirements from the manufacturer of each mechanical, electrical or plumbing component of the designated seismic system, documenting that the requirements are met shall be submitted to the *building official* as specified in Section 1704.5.
- OSSC 1705.21** **1705.21 Radon mitigation inspections.** Where radon mitigation systems are required by Section 1811, special inspections shall be provided in accordance with Sections 1705.21.1 and 1705.21.2.
- 1705.21.1 Soil-gas-retarder membrane.** After the subfloor preparation inspection and prior to the placement of concrete, a special inspector shall verify that the soil-gas-retarder membrane installation conforms with Section 1811.2.2.
- 1705.21.2 Sealing of construction joints, penetrations, cracks and other connections.** After the placement of concrete, a special inspector shall verify conformance with Section 1811.2.3.2.

Section 1708 In-Situ Load Tests

- IBC 1708.1** **1708.1 General.** Whenever there is a ~~reasonable doubt as to~~ documented concern submitted to the municipality regarding the stability or load-bearing capacity of a completed building, structure or portion thereof for the expected *loads*, or where notification of such concern is provided by the registered design professional in responsible charge, the building official is authorized to require an engineering assessment ~~shall be required~~. The engineering assessment shall involve either a structural analysis or an in-situ load test, or both. The structural analysis shall be based on actual material properties and other as-built conditions that affect stability or load-bearing capacity, and shall be conducted in accordance with the applicable design standard. The in-situ load tests shall be conducted in accordance with Section 1708.2. If the building, structure or portion thereof is found to have inadequate stability or load-bearing capacity for the expected *loads*, modifications to ensure structural adequacy or the removal of the inadequate construction shall be required.

Section 1709 Preconstruction Load Tests

- IBC 1709.5.3** **1709.5.3 Windborne debris protection.** *Not adopted*
- IBC 1709.5.3.1** **1709.5.3.1 Impact protective systems testing and labeling.** *Not adopted*

CHAPTER 18

SOILS AND FOUNDATIONS

Section 1803 Geotechnical Investigations

IBC 1803.1 **1803.1 General.** Geotechnical investigations shall be conducted in accordance with Section 1803.2 and reported in accordance with Section 1803.6. Where required by the *building official* or where geotechnical investigations involve in-situ testing, laboratory testing or engineering calculations, such investigations shall be conducted by a *registered design professional*.

Sites for structures and facilities defined by ORS 455.447 as *major structures* or *Risk Category III* or *IV* buildings and other structures shall be evaluated on a site-specific basis for vulnerability to seismic-induced geologic hazards as required by Section 1803.3.2.

OSSC 1803.3.2 **1803.3.2 Site-specific seismic hazard investigation.** Sites for structures and facilities defined by ORS 455.447 as *major structures* or *Risk Category III* or *IV* buildings and other structures shall be evaluated on a site-specific basis for vulnerability to seismic-induced geologic hazards and reported in accordance with Section 1803.6.1. The degree of detail of investigation shall be compatible with the type of development and geologic complexity, and the structural system required by other parts of this code. This evaluation shall be done by an especially qualified engineer or engineering geologist registered by the state to practice as such. Such an evaluation and report may require the services of persons especially qualified in fields of engineering seismology, earthquake geology or geotechnical engineering.

1803.3.2.1 Design earthquake. Building sites required to be investigated as provided in Section 1803.3.2 shall, at a minimum, address earthquakes from:

1. A shallow crustal earthquake on real or assumed faults near the site, subject to evaluation. The minimum design earthquake shall in no case be considered less than a moment magnitude of 6.0 or the design earthquake ground motion acceleration determined in accordance with Section 1613.
2. A deep earthquake with a moment magnitude greater than 7.0 on the seismogenic part of the subducting plate of the Cascadia Subduction Zone.
3. An earthquake on the seismogenic part of the interface between the Juan de Fuca Plate and the North American Plate on the Cascadia Subduction Zone with a minimum moment magnitude of 8.5.

OSSC 1803.6.1 **1803.6.1 Site-specific seismic hazard report.** In addition to the reporting requirements of Section 1803.6, for building sites requiring a site-specific seismic hazard investigation per Section 1803.3.2, the report shall include, but not be limited to, the following:

1. A geologic profile of the site extending to bedrock, either measured or estimated.
2. An explanation of the regional geologic, tectonic and seismic settings.
3. A literature review of the regional seismic or earthquake history (i.e., potential seismic source, maximum credible earthquakes, recurrence intervals, etc.).
4. Selection criteria for seismic sources and recommendations for a design earthquake.
5. Selection criteria and recommended ground response, including local amplification effects.
6. An evaluation of the site-specific seismic hazards, including earthquake-induced landslide, liquefaction, settlement and subsidence, fault rupture, seiche, tsunami inundation, and other seismic hazards at the site, including the effects of local geology and topography.

In addition to Items 1 through 6, the *building official* may require other reports and calculations to be provided by seismologists, geophysicists or professional engineers to evaluate the *seismic hazards*. Such additional investigation may include a study of aerial photographs; a review of local groundwater data, penetrometer results, and geophysical surveys; and further actions such as making exploratory borings, trenching across faults or suspicious zones, and laboratory testing of soil and rock.

1803.6.1.1 Site-specific seismic hazard report review. Provision shall be made by the *municipality* for qualified review of the site-specific seismic hazard report for conformance with Section 1803. Persons *approved* to do such review shall have qualifications deemed equivalent to the person who prepared the report. This review may be by the *municipality's* staff, a consultant firm or a committee established by the *municipality*. With the approval of the *building official*, the owner may provide a peer review. Where the review is provided by a party other than the *municipality's* staff, the review shall consist of a written summary of the reviewer's assessment of the overall adequacy of the site report and a listing of additional questions or factors that need to be addressed.

Section 1804 Excavation, Grading and Fill

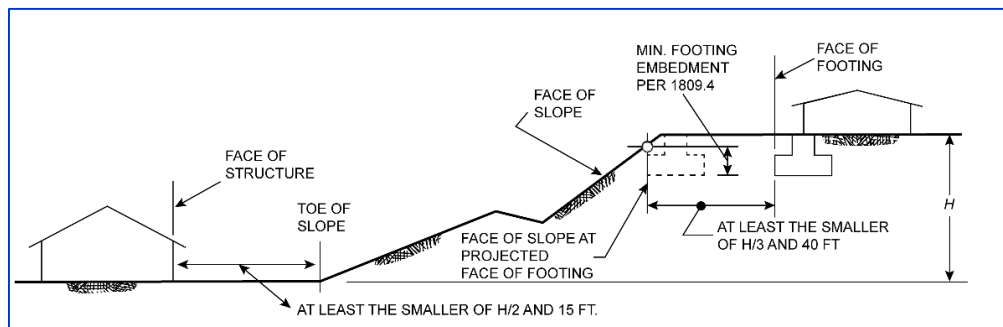
IBC 1804.5 **1804.5 Grading and fill in flood hazard areas.** In flood hazard areas established by the flood plain administrator, grading, fill or both shall be approved by the flood plain administrator.

~~In flood hazard areas established in Section 1612.3, grading, fill or both, shall not be approved:
(The rest of this section is deleted)~~

OSSC 1804.8 **1804.8 Under-floor drainage.** Where required by the building official, the ground under any building or portion thereof shall be sloped to a low point and drainage facilities shall be installed to provide positive drainage from the area under the building. The drainage facilities shall be in accordance with the Plumbing Code. If the premises abut a curbed street, or a storm sewer is available, and if the grade is favorable, a gravity drainage system from under the building shall extend to the gutter, storm sewer or other approved means. Crawl space drains may be connected to a footing drain.

Section 1808 Foundations

IBC Figure 1808.7.1



For SI: 1 foot = 304.8 mm.

**FIGURE 1808.7.1
FOUNDATION CLEARANCES FROM SLOPES**

OSSC 1808.8.5.1 **1808.8.5.1 Grounding of foundation reinforcement.** Where concrete reinforcing bars are installed in concrete footings, a grounding electrode system for each building or structure provided with electrical service shall be installed in accordance with the Electrical Code.

Section 1809 Shallow Foundations

IBC 1809.5.1 **1809.5.1 Frost protection at required exits.** For sites located at elevations above 4,000 feet (1219.2 m), frost protection shall be provided at exterior landings for all required exits with outward-swinging doors. ~~Frost protection shall only be required to the extent necessary to ensure the unobstructed opening of the required exit doors.~~

Section 1811 Radon Control Methods—Public Buildings

OSSC 1811

1811.1 Scope. The provisions of this section apply to new public buildings constructed in Baker, Clackamas, Hood River, Multnomah, Polk, Washington and Yamhill Counties, for which initial building permits are issued on or after April 1, 2013.

Exception: Public buildings of Group R-2 or R-3 occupancy classifications shall comply with Section 1812.

Public buildings shall, at a minimum, be provided with a passive soil depressurization (PSD) radon gas mitigation system in accordance with this section. PSD slab-on-grade construction shall comply with Section 1811.2. Active soil depressurization systems (ASD) shall comply with Sections 1811.2 and Section 1811.3. Public buildings using crawl space construction shall comply with the crawl space provisions of Section 1812 except that radon vent pipes shall be not less than 6 inches (152 mm) in diameter.

Exceptions: Public buildings described in Items 1 through 6 are exempt from compliance with this section. Elevated buildings that comply with all provisions of Item 7 are exempt from compliance with other portions of this section.

1. Temporary structures.
2. Freestanding greenhouses used exclusively for the cultivation of live plants.
3. Open-air viewing stands, grandstands and bleachers.
4. Farm structures used only for storage or to shelter animals.
5. Buildings with Groups S, H, and U occupancies, and special industrial occupancies in accordance with Section 503.1.1.
6. Buildings equipped with a mechanical ventilation system providing a minimum outside air rate of 20 percent and a ventilation rate of one of the following:
 - 6.1. 6 air changes per hour.
 - 6.2. 1 cfm per square foot of floor area.
7. Elevated buildings that satisfy all of the following conditions:
 - 7.1. The structure shall be separated from the ground by a vertical separation, measured between the final grade and the lower surface of the floor, of at least 18 inches (457 mm).
 - 7.2. All pilings, posts, piers or other supports shall be solid, or if hollow, shall be capped by a solid masonry unit or sealed at the surface of the soil with a construction complying with all applicable portions of Section 1811.2.4.

7.3. Enclosures of any kind, including but not limited to chases, storage rooms, elevator shafts and stairwells, which connect between the soil and the structure, shall comply with all applicable provisions of Section 1811.2 and shall have a soil contact area of less than 5 percent of the projected building floor area.

7.4. The perimeter of the structure, from the ground plane to the lower surface of the lowest floor shall be completely open for ventilation.

1811.2 Slab-on-grade. The design and installation of slab-on-grade PSD systems shall incorporate the five requirements as listed here. The design and construction requirements for each are detailed in the respective sections that follow.

1. Subfloor preparation: Place a layer of gas-permeable material under all concrete slabs.
2. Soil-gas-retarder membrane: The membrane shall be placed to minimize seams and to cover all of the soil below the building floor. Seal major radon entry routes, including slab and foundation joints/cracks, as well as utility and pipe penetrations.
3. Concrete placement: Follow specifications to limit the uncontrolled cracking of floor slabs, including mix design, placing practices and curing practices.
4. Subslab barriers: Eliminate barriers to subslab airflow such as subslab walls or provide subslab soil exhaust systems for each area.
5. Subslab soil exhaust system ducts (vent pipes): Install a 6-inch (152 mm) diameter or equivalent subslab soil exhaust system duct from the radon suction pit to the outdoors.

1811.2.1 Subfloor preparation. To ensure the proper extension of the pressure field under the entire building, a layer of gas-permeable material shall be placed under all concrete slabs. The gas-permeable layer shall consist of one of the following:

1. A layer of aggregate complying with this section.
2. A uniform layer of sand (native or fill) a minimum of 4 inches (102 mm) thick, overlain by a layer or strips of geotextile drainage matting designed to allow the lateral flow of soil gases.
3. Other materials, systems or floor designs with demonstrated capability to permit depressurization across the entire subfloor area.

1811.2.1.1 Aggregate. A 4-inch to 6-inch (102 mm to 152 mm) layer of clean, coarse aggregate without fines shall be placed beneath the slab. Where approved, pressure field extension may be accomplished through the use of mats or a gas conveyance piping system in accordance with Section 1811.3.4.

1811.2.1.1.1 Aggregate specifications. Crushed aggregate shall meet Size #5 specifications as defined in ASTM C33, *Standard Specification for Concrete Aggregates*. Such aggregate shall be in the range of 1/2 to 1-inch (13 mm to 25 mm) diameter with less than 10 percent passing through a 1/2-inch (13 mm) sieve and has a free void space of approximately 50 percent.

1811.2.1.1.2 Aggregate placement. Place a minimum of 4 to 6 inches (102 mm to 152 mm) of aggregate evenly under the entire slab. If the aggregate is placed on top of a material with excessive fines and compaction of the aggregate is required for structural or other code considerations, a geotextile fabric or an additional reinforced vapor retarder is permitted to be placed beneath the aggregate. Where gas conveyance piping systems are installed, aggregate must extend a minimum of 2 inches (51 mm) over the top of the piping.

1811.2.2 Soil-gas-retarder membrane. A soil-gas-retarder membrane shall be placed over the aggregate or other permeable material prior to placement of the slab in accordance with Section 1811.2.

1811.2.2.1 Materials. Acceptable soil-gas-retarder membranes shall consist of a single layer of polyethylene, not less than 0.010 inch (10 mils) thick with a maximum perm rating of 0.3. Polyvinyl chloride (PVC); ethylene propylene diene monomer (EPDM); neoprene; or other nondeteriorating, nonporous material may be used in lieu of polyethylene, provided that the installed thickness of the alternate material has greater or equal tensile strength, resistance to water-vapor transmission, resistance to puncture, and resistance to deterioration determined in accordance with ASTM E154 and ASTM E1745. The membrane shall be placed to minimize seams and to cover all of the soil below the building floor.

1811.2.2.2 Tape. Tape used to install the soil-gas retarder shall have a minimum width of 2 inches (25 mm) and shall be pressure-sensitive vinyl or other nondeteriorating pressure-sensitive tape compatible with the surfaces being joined. Paper tape and/or cloth tape shall not be used for these purposes.

1811.2.2.3 Mastic. Mastic used to install the soil-gas retarder shall be compatible with the surfaces being joined and shall be installed in accordance with the manufacturer's recommendations for the materials, surface conditions and temperatures involved. Mastic may be used to join sections of membrane to one another or to elements of the building foundation, or to seal penetrations in the membrane.

1811.2.2.4 Installation. The soil-gas retarder shall be placed under the entire soil-contact area of the floor in a manner that minimizes the required number of joints and seams. Care shall be taken to prevent damage to the membrane during the construction process.

Note: In buildings incorporating the subslab portions of an active soil-depressurization system, the soil-gas retarder serves an important second purpose: to prevent mastic, cement or other materials from blocking the pressure distribution manifolds or pits.

1811.2.2.5 Seams. Seams between portions of the soil-gas retarder shall maintain a minimum of 12 inches (305 mm) of lap when concrete is placed. This may be accomplished by securing the lapped edges of the membrane with tape or mastic or using larger unsecured overlaps prior to placing concrete.

1811.2.2.6 Slab edges and joints. The soil-gas retarder shall fully cover the soil beneath the building floor. Where the slab edge is cast against a foundation wall or grade beam, the soil-gas retarder shall contact the foundation element and shall not extend vertically into the slab more than one-half the slab thickness.

1811.2.2.7 Penetrations. At all points where pipes, conduits, reinforcing bars or other objects pass through the soil-gas-retarder membrane, the membrane shall be fitted to within 1/2 inch (13 mm) of the penetration and sealed with tape or mastic to the penetration.

Where penetrations occur within 24 inches (610 mm) of a soil-depressurization-system mat or pit, the gap between the penetrating object and the soil-gas retarder shall be taped closed. Where necessary to meet this requirement, a second layer of the membrane, cut so as to provide a minimum 12-inch (305 mm) lap on all sides, shall be placed over the object and shall be sealed to the soil-gas retarder with a continuous band of tape.

1811.2.2.8 Punctures, cuts and tears. All damaged portions of the soil-gas-retarder membrane shall be sealed with tape or with a patch made from the same or compatible material, cut so as to provide a minimum 12-inch (305 mm) lap from any opening and taped continuously about its perimeter.

1811.2.2.9 Mastics. Mastic may be used to join sections of soil-gas retarder to one another or to elements of the building foundation, or to seal penetrations in the soil-gas retarder, provided that mastic is kept at least 24 inches (610 mm) from any portion of a soil-depressurization-system mat or pit. Only tape may be used to seal the soil-gas-retarder membrane within 24 inches (610 mm) of a soil-depressurization-system mat or pit.

1811.2.2.10 Repairs. Where portions of an existing slab have been removed, a soil-gas-retarder membrane shall be carefully fitted to the opening and all openings between the membrane and the soil closed with tape or mastic prior to replacement of the slab. Special care must be exercised to ensure that mastic does not enter any portion of a soil-depressurization system located beneath the slab.

1811.2.3 Concrete slabs—General. Concrete slabs shall be constructed in accordance with the provisions of Chapter 19.

1811.2.3.1 Compressive strength. Design strength for all concrete mixes used in the construction of slab-on-grade floors shall be a minimum of 3,000 psi at 28 days and shall be designed, delivered and placed in accordance with ASTM C94.

1811.2.3.2 Sealing of construction joints, penetrations, cracks, and other connections. Sealing of construction joints, penetrations, cracks, and other connections shall be in accordance with Sections 1811.2.3.2.1 through 1811.2.3.2.4.

1811.2.3.2.1 Sealants. Sealants shall be selected and installed in compliance with ASTM C920, *Standard Specification for Elastomeric Joint Sealant*, and ASTM C1193, *Standard Guide for Use of Joint Sealants*.

1. Sealant materials shall be compatible with the materials they join, including curing compounds and admixtures, and with materials that will be applied over them, including floor finishing materials.
2. Field-molded sealants shall be installed in sealant reservoirs proportioned, cleaned of laitance and prepared in accordance with the manufacturer's recommendations.

Note: For elastomeric sealants, this generally requires the installation of a bond breaker.

3. Where the installed sealant is not protected by a finished floor or other protective surface, it shall be suitable to withstand the traffic to which it will be exposed.
4. Waterstops shall be preformed using polyvinyl chloride or other noncorrosive material.

1811.2.3.2.2 Joints. All joints between sections of concrete floor slabs, between the floor slab and a wall or other vertical surface, or between a section of floor and another object that passes through the slab shall be sealed to prevent soil gas entry in accordance with the provisions of this section. Joint design depends on the amount and type of movement that the joint must withstand. No portion of any joint shall be covered or rendered inaccessible unless the seal has first been inspected and approved. All such joints shall be sealed prior to the issuance of a certificate of occupancy.

1. Butt joints. All nonbonded butt joints shall be sealed to prevent radon entry using an elastomeric sealant or a waterstop as specified in Section 1811.2.3.2.1. The sealant reservoir shall be sufficiently large to prevent failure of the sealant or waterstop, but in no case shall the sealant reservoir be less than $\frac{1}{4}$ inch by $\frac{1}{4}$ inch (6.4 mm by 6.4 mm) in cross-section.

2. Lap joints. All nonbonded lap joints shall be sealed with either a field-molded or preformed elastomeric sealant or with a flexible waterstop as specified in Section 1811.2.3.2.1. The lap joint shall be sufficiently large to prevent failure of the sealant or waterstop, but in no case shall the sealant reservoir be less than $\frac{1}{2}$ inch by $\frac{1}{2}$ inch (12.7 mm by 12.7 mm) in cross-section.
3. Isolation joints. All nonbonded isolation joints shall be sealed with either a field-molded or preformed elastomeric sealant or with a flexible waterstop as specified in Section 1811.2.3.2.1. Isolation joints shall be sufficiently large to prevent failure of the sealant or waterstop, but in no case shall the sealant reservoir be less than $\frac{1}{2}$ inch by $\frac{1}{2}$ inch (12.7 mm by 12.7 mm) in cross-section.
4. Control or contraction joints. Control or contraction joints may be used to limit cracking of floor slabs. In locations where, continued movement of the slab portions can be reasonably expected, flexible sealants must be installed in reservoirs complying with the requirements of Item 1 on butt joints, or a flexible waterstop must be used.
5. Construction joints. All bonded construction joints shall be sealed to prevent radon entry using either a rigid or an elastomeric sealant, or a waterstop as previously specified. Where movement of the joint is not prevented by continuous reinforcing and tie bars, flexible sealants must be installed in reservoirs complying with the requirements of Item 2 on lap joints, or a flexible waterstop must be used.

1811.2.3.2.3 Cracks. All cracks in concrete slabs that are supported on soil or span over exposed soil and are used as floors for conditioned spaces or enclosed spaces adjacent to or connected to conditioned spaces shall be sealed against radon entry in accordance with the provisions of this section and Section 1811.2.3.2.1.

Note: Sealing should occur as late in the construction process as possible.

1. Cracks greater than $\frac{1}{4}$ inch (6.4 mm) wide, all cracks that exhibit vertical displacement, all cracks that connect weakened zones in the slab such as vertical penetrations or reentrant corners, and all cracks that cross changes in materials or planes in the structure shall be sealed with a flexible field-molded elastomeric sealant installed in accordance with Section 1811.2.3.2.2, Item 3, on isolation joints.
2. Cracks greater than $\frac{1}{16}$ inch (1.6 mm) in width that do not meet any of the conditions described in Item 1 shall be enlarged to contain a sealant reservoir not less than $\frac{1}{4}$ inch by $\frac{1}{4}$ inch (6.4 mm by 6.4 mm) in cross-section along the entire length of the crack and shall be sealed with a flexible, field-molded elastomeric sealant installed in accordance with Section 1811.2.3.2.2, Item 1, on butt joints.

3. Cracks less than $\frac{1}{16}$ inch (1.6 mm) in width that do not meet any of the conditions described in Item 1 may be left unsealed.

1811.2.3.2.4 Stakes, pipe penetrations and other objects. All objects that pass through the slab shall be sealed gastight. A sealant reservoir, appropriately dimensioned to accommodate any differential movement between the object and the concrete, shall be formed continuously around the object, and the joint shall be sealed with a field-molded elastomeric sealant as prescribed for Section 1811.2.3.2.1, Item 3, on isolation joints and in accordance with the provisions of Section 1811.2.3.2.1. Where pipes or other penetrations are separated from the concrete by flexible sleeves, the sleeve shall be removed to provide bonding of the sealant to the object. Where stakes are used to support plumbing, electrical conduits or other objects that will penetrate the slab, the stakes shall be solid, nonporous and resistant to decay, corrosion and rust. Special care must be taken to avoid honeycombing between multiple or ganged penetrations.

1. Large utility service openings through the slab shall be sealed gastight. For slab-on-grade construction, this can be accomplished by fully covering the exposed soil with a vapor-retarder membrane, covered to a depth of not less than 1 inch (25 mm) with an elastomeric sealant. Alternatively, the opening may be closed with an expansive concrete or hydraulic cement to within $\frac{1}{2}$ inch (12.7 mm) of the top of the slab, and the remaining $\frac{1}{2}$ inch (12.7 mm) filled with an elastomeric sealant. Where the opening connects to a crawl space, the opening shall be closed with sheet metal or other rigid impermeable materials and sealed with an elastomeric sealant compatible with materials and conditions.
2. Openings made through existing slabs must be sealed to meet the appropriate provisions of this section. If the opening is partially repaired with concrete, any resulting crack shall be sealed in accordance with the Section 1811.2.3.2.3.
3. Any sump located in a habitable portion of a building and connecting to the soil, either directly or through drainage piping, shall be lined with a gasketed lid. The lid shall be attached so as to provide a gastight seal between the sump and the access space above. Where interior footing drainage systems extend out beneath the footing, the drain must be sealed airtight where it passes beneath the footing.

1811.2.4 Walls in contact with soil gas. Walls separating below-grade conditioned space from the surrounding earth or from a crawl space or other enclosed space with an exposed earth floor shall be isolated from the soil as required by this section. Foundation walls consisting of cavity walls or constructed of hollow masonry products, or of any material in such a way as to create an airspace within the wall, shall be capped at the floor level of the first finished floor they intersect. The cap shall be either at least 8 inches (203 mm) of solid concrete or concrete-filled block, or a cap that provides airflow resistance at least equal to the adjacent floor. No crack, honeycomb, duct joint, pipe, conduit chase or other opening in the wall shall be allowed to connect soil gas to a conditioned space or to an enclosed space adjacent to or connected to a conditioned space.

1811.2.4.1 Materials. Walls governed by the provisions of this section shall be constructed of reinforced concrete or solid reinforced masonry construction.

1811.2.4.2 Waterproofing. Walls governed by the provisions of this section shall be constructed with a continuous waterproofing membrane applied in accordance with Section 1805.3.2.

1811.2.4.2.1 Utility penetrations. All below-grade utility penetrations through walls in partial or full contact with the soil shall be closed and sealed with an approved sealant material (see Section 1811.2.3.2.1). This seal shall be made on both faces of the wall. Where conduits or ducts do not provide a continuous and gastight separation from the soil, the end of the conduit or duct must be sealed in accordance with the provisions of Section 1811.2.3.2.1 to prevent soil gas entry.

1811.2.4.3 Doors and service openings. Doors, hatches or removable closures of any kind that can create an opening between the interior and a crawl space shall be gasketed and installed with a latch or other permanent fastening device.

1811.2.5 Subslab soil exhaust system ducts (SSESD). SSESDs shall be provided in accordance with this section and shall run continuous from below the slab to the termination point described in Section 1811.2.5.5. Each SSESD shall consist of one 6-inch (152 mm) diameter solid pipe.

Exception: For other than active soil-depressurization systems, multiple pipes providing the same cross-sectional area may be used.

All annular spaces between the SSESD and the floor slab shall be sealed airtight. In addition, all SSESD joints shall be sealed airtight. Penetrations of SSESDs through fire-resistive construction shall comply with the applicable sections of Chapter 7 of this code. SSESDs shall be located within the building's insulated envelope and may be combined above the slab, where the cross-sectional area of all combined SSESDs is maintained to the required termination point.

1811.2.5.1 Location. One SSES D shall be installed for every 2,000 square feet (186 m²), or portion thereof, of building subslab area served. Where subslab areas are isolated by subslab walls, each subslab area shall be provided with separate SSES Ds.

1811.2.5.2 Materials. SSES D material shall be air duct material *listed and labeled* to the requirements of UL 181 for Class 0 air ducts or piping materials that comply with the *Plumbing Code* as building sanitary drainage and vent pipe.

1811.2.5.3 Grade. SSES Ds shall not be trapped and shall have a slope of not less than one-eighth unit vertical in 12 units horizontal (1-percent slope).

1811.2.5.4 Subslab aperture. SSES Ds shall be embedded vertically into the subslab aggregate or other permeable material before the slab is cast. A “T” fitting or equivalent method shall be used to ensure that the SSES D opening remains within the subslab permeable material. Alternatively, the SSES D shall be inserted directly into an interior perimeter drain tile loop or through a sealed sump cover where the sump is exposed to the subslab aggregate or connected to it through a drainage system.

1811.2.5.5 Termination. SSES Ds shall extend through the roof and terminate at least 12 inches (305 mm) above the roof and at least 10 feet (3048 mm) from any operable openings or air intake.

1811.2.5.6 Identification. All exposed and visible interior SSES Ds shall be permanently identified with at least one label on each floor and in accessible attics. The label shall be a tag, stencil or other approved marking that states: “Radon Reduction System.”

1811.2.5.7 Combination foundations. Combination basement/crawl space or slab-on-grade/crawl space foundations shall have separate SSES Ds installed in each type of foundation area. Each SSES D shall terminate above the roof or shall be connected to a single SSES D that terminates above the roof.

1811.3 Active soil depressurization (ASD). ASD systems shall comply with Section 1811.2, as modified by this section.

1811.3.1 Design. ASD systems shall comply with this section or may be designed by a *registered design professional* in accordance with accepted engineering practices for the mitigation of radon.

1811.3.2 ASD SSES D location. One SSES D shall be installed for every 4,000 square feet (372 m²), or portion thereof, of building subslab area served by an ASD system. Subslab areas isolated by subslab wall footings shall be provided with separate SSES Ds in the number as required in this section.

Exception: One SSES D shall be installed for every 15,000 square feet (1393 m²), or portion thereof, of building subslab area served by an ASD system utilizing a gas conveyance piping system complying with Section 1811.3.4. Subslab areas isolated by subslab wall footings shall be provided with separate SSES Ds.

1811.3.3 SSES D blower sizing. Each SSES D shall be equipped with a blower having a minimum capacity as follows:

1. 200 cubic feet per minute (CFM) for SSES Ds connected to a gas conveyance piping system complying with Section 1811.3.4.
2. 100 CFM for all other ASD systems.

1811.3.3.1 Alarms. ASD SSES D blowers shall be equipped with an audible alarm located in a normally occupied location to indicate fan malfunction.

1811.3.4 Gas conveyance piping systems (GCPS). Gas conveyance piping systems (GCPS) shall incorporate a perforated pipe system connected to a centralized plenum box. One length of perforated pipe shall be provided for each 50 linear feet (15 240 mm), or portion thereof, of the area to be served, measured in any right angle to the perimeter. Pipe lengths shall terminate not farther than 5 feet (1524 mm) from an exterior wall footing or interior wall cutoff footing (see Figure 1811.3.4). The pipe shall be embedded in the middle of a gravel trench that is not less than 12 inches wide by 8 inches deep (305 mm by 203 mm), with the perforation holes oriented to allow for both the free conveyance of gas into the pipe and the drainage of any condensation that may collect. The piping shall be a standard 3-inch (76 mm) diameter perforated pipe as used for typical subterranean drain systems. The piping system shall be installed such that it will intersect at a centralized plenum box that is not less than 24 square inches (15 484 mm²) by 8 inches deep (203 mm) that will allow the free flow of soil gas into an SSES D complying with Section 1811.2.5.

Where the exception for the installation of one SSES D for every 15,000 square feet (1393 m²) is used, the 24 square inches (15 484 mm²) by 8 inches deep (203 mm) plenum box shall be eliminated. In lieu of the plenum box, all piping at intersections and at the transition to the SSES D shall be positively connected such that no air leakage occurs at the pipe joints.

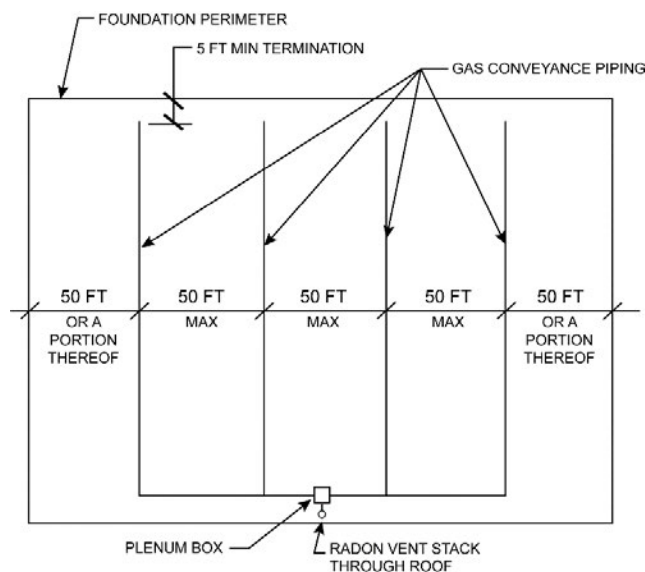


FIGURE 1811.3.4
GAS CONVEYANCE PIPING

Section 1812 Radon Control Methods—Group R-2 and R-3 Occupancies

OSSC 1812

1812.1 Scope. The provisions of this section apply to new Group R-2 and R-3 occupancies constructed in Baker, Clackamas, Hood River, Multnomah, Polk, Washington and Yamhill Counties for which initial building permits are issued on or after April 1, 2011.

1812.2 General. The following construction techniques are intended to resist radon entry and prepare the building for post-construction radon mitigation. See Figure 1812.2(1), 812.2(2), and 1812.2(3).

1812.2.1 Subfloor preparation. A layer of gas-permeable material shall be placed under all concrete slabs and other floor systems that directly contact the ground and are within the walls of the living spaces of the building to facilitate future installation of a subslab depressurization system, if needed. The gas-permeable layer shall consist of one of the following:

1. A uniform layer of clean aggregate not less than 4 inches (102 mm) thick. The aggregate shall consist of material that will pass through a 2-inch (51 mm) sieve and be retained by a 1/4-inch (6.4 mm) sieve.
2. A uniform layer of sand (native or fill) not less than 4 inches (102 mm) thick, overlaid by a layer or strips of geotextile drainage matting designed to allow the lateral flow of soil gases.
3. Other materials, systems or floor designs with demonstrated capability to permit depressurization across the entire subfloor area.

1812.2.2 Soil-gas retarder. A minimum 6-mil (0.15 mm) [or 3-mil (0.075 mm) cross-laminated] polyethylene or equivalent flexible sheeting material shall be placed on top of the gas-permeable layer prior to casting the slab or placing the floor assembly to serve as a soil-gas retarder by bridging any cracks that develop in the slab or floor assembly and to prevent concrete from entering the void spaces in the aggregate base material. The sheeting shall cover the entire floor area with separate sections of sheeting lapped at least 12 inches (305 mm). The sheeting shall fit closely around any pipe, wire or other penetrations of the material. All punctures or tears in the material shall be sealed or covered with additional sheeting.

1812.2.3 Entry routes. Potential radon entry routes shall be closed in accordance with Sections 1812.2.3.1 through 1812.2.3.10.

1812.2.3.1 Floor openings. Annular spaces around bathtubs, showers, water closets, pipes, wires or other objects that penetrate concrete slabs or other floor assemblies shall be filled with a polyurethane caulk or equivalent sealant applied in accordance with the manufacturer's recommendations.

1812.2.3.2 Concrete joints. All control joints, isolation joints, construction joints and any other joints in concrete slabs or between slabs and foundation walls shall be sealed with a caulk or sealant. Gaps and joints shall be cleared of loose material and filled with polyurethane caulk or other elastomeric sealant applied in accordance with the manufacturer's recommendations.

1812.2.3.3 Condensate drains. Condensate drains shall be trapped or routed through nonperforated pipe to daylight.

1812.2.3.4 Sumps. Sump pits open to soil or serving as the termination point for subslab or exterior drain tile loops shall be covered with a gasketed or otherwise sealed lid. Sumps used as the suction point in a subslab depressurization system shall have a lid designed to accommodate the vent pipe. Sumps used as a floor drain shall have a lid equipped with a trapped inlet.

1812.2.3.5 Foundation walls. Hollow block masonry foundation walls shall be constructed with either a continuous course of solid masonry, one course of masonry grouted solid, or a solid concrete beam at or above finished ground surface to prevent passage of air from the interior of the wall into the living space. Where a brick veneer or other masonry ledge is installed, the course immediately below that ledge shall be sealed. Joints, cracks or other openings around all penetrations of both exterior and interior surfaces of masonry block or wood foundation walls below the ground surface shall be filled with polyurethane caulk or equivalent sealant. Penetrations of concrete walls shall be filled.

1812.2.3.6 Dampproofing. The exterior surfaces of portions of concrete and masonry block walls below the ground surface shall be dampproofed in accordance with Section 1805.2.

1812.2.3.7 Air-handling units. Air-handling units in crawl spaces shall be sealed to prevent air from being drawn into the unit.

Exception: Units with gasketed seams or units that are otherwise sealed by the manufacturer to prevent leakage.

1812.2.3.8 Ducts. Ductwork passing through or beneath a slab shall be of seamless material unless the air-handling system is designed to maintain continuous positive pressure within such ducting. Joints in such ductwork shall be sealed to prevent air leakage.

Ductwork located in crawl spaces shall have all seams and joints sealed by closure systems in accordance with Section 603.9 of the *Mechanical Code*. Where fan systems circulate air to living spaces, all ductwork located in the crawl space shall be positive-pressure ductwork.

1812.2.3.9 Crawl space floors. Openings around all penetrations through floors above crawl spaces shall be caulked or otherwise filled to prevent air leakage.

1812.2.3.10 Crawl space access. Access doors and other openings or penetrations between basements and adjoining crawl spaces shall be closed, gasketed or otherwise filled to prevent air leakage.

1812.2.4 Crawl space mitigation system. In buildings with crawl space foundations, a system complying with Section 1812.2.4.1 shall be installed during construction.

Exception: Buildings in which an approved mechanical crawl space ventilation system or other equivalent system is installed.

1812.2.4.1 Passive submembrane depressurization system.

1812.2.4.1.1 Ventilation. Crawl spaces shall be provided with vents to the exterior of the building. The minimum net area of ventilation openings shall be not less than 1 square foot for each 150 square feet (0.67m² for each 100 m²) of crawl space area. Ventilation openings shall otherwise comply with Section 1202.4. Operable louvers, dampers, or other means to temporarily stop the ventilation shall not be permitted.

1812.2.4.1.2 Soil-gas retarder. The soil in crawl spaces shall be covered with a continuous soil-gas retarder in conformance with Section 1812.2.2. The soil-gas retarder shall extend to all foundation walls enclosing the crawl space area.

1812.2.4.1.3 Vent pipe. A vent pipe complying with the requirements of Section 1812.2.6 for subslab soil exhaust system ducts.

1812.2.5 Passive subslab depressurization system (basement or slab-on-grade). In basement or slab-on-grade buildings, subslab soil exhaust system ducts complying with Section 1812.2.6 shall be installed during construction.

1812.2.6 Subslab soil exhaust system ducts (SSESD). SSESDs shall be provided in accordance with this section and shall run continuous from below the soil-gas retarder to the termination point described in Section 1812.2.6.5. SSESDs shall consist of one 3- or 4-inch diameter solid pipe or multiple pipes providing the same cross-sectional area. All annular spaces between the SSESD and floor slabs or soil-gas retarders shall be sealed airtight. In addition, all SSESD joints shall be sealed airtight. Penetrations of SSESDs through fire-resistive construction shall comply with the applicable sections of Chapter 7 of this code. SSESDs shall be located within the building's insulated envelope and may be combined above the slab where the cross-sectional area of all combined SSESDs is maintained to the required termination point.

1812.2.6.1 Location. One SSESD shall be installed for every 2,000 square feet (186 m²), or portion thereof, of building subslab or crawl space area served. Where subslab areas are isolated by subslab walls, each subslab area shall be provided with separate SSESDs. SSESDs shall connect to a single duct that terminates above the roof or each individual SSESD shall terminate separately above the roof.

1812.2.6.2 Materials. SSES material shall be air duct material *listed and labeled* to the requirements of UL 181 for Class 0 air ducts, or piping materials that comply with the *Plumbing Code* as building sanitary drainage and vent pipe.

1812.2.6.3 Grade. SSESs shall not be trapped and shall have a slope of not less than one-eighth unit vertical in 12 units horizontal (1-percent slope).

1812.2.6.4 Subslab aperture. SSESs shall be embedded vertically into the subslab aggregate or other permeable material prior to casting a slab. A “T” fitting or equivalent method shall be used to ensure that the SSES opening remains within the gas permeable material. Alternatively, the SSES shall be inserted directly into an interior perimeter drain tile loop or through a sealed sump cover where the sump is exposed to the subslab aggregate or connected to it through a drainage system.

1812.2.6.5 Termination. SSESs shall be extended up through the building floors, and terminate not less than 12 inches (305 mm) above the surface of the roof in a location not less than 10 feet (3048 mm) away from any window or other opening into the conditioned spaces of the building that is less than 2 feet (610 mm) below the exhaust point, and 10 feet (3048 mm) from any window or other opening in adjoining or adjacent buildings.

1812.2.6.6 Identification. All exposed and visible interior SSESs shall be permanently identified with at least one label on each floor and in accessible attics. The label shall be by means of a tag, stencil or other approved marking that states: “Radon Reduction System.”

1812.2.6.7 SSES accessibility. SSESs shall be accessible for future fan installation through an attic or other area outside the habitable space.

Exception: The SSES need not be accessible in an attic space where an approved rooftop electrical supply is provided for future use.

1812.2.6.8 Combination foundations. Combination basement/crawl space or slab-on-grade/crawl space foundations shall have separate radon vent pipes installed in each type of foundation area. Each radon vent pipe shall terminate above the roof or shall be connected to a single vent that terminates above the roof.

1812.2.7 Building depressurization. Joints in air ducts and plenums in unconditioned spaces shall meet the requirements of Section 603 of the *Mechanical Code*. Thermal envelope air infiltration requirements shall comply with the *Energy Code*. Fireblocking shall meet the requirements contained in Section 718.2.

1812.2.8 Power source. To provide for future installation of an active submembrane or subslab depressurization system, an electrical circuit terminated in an approved box shall be installed during construction in the attic or other anticipated location of vent pipe fans. An electrical supply shall also be accessible in anticipated locations of system failure alarms.

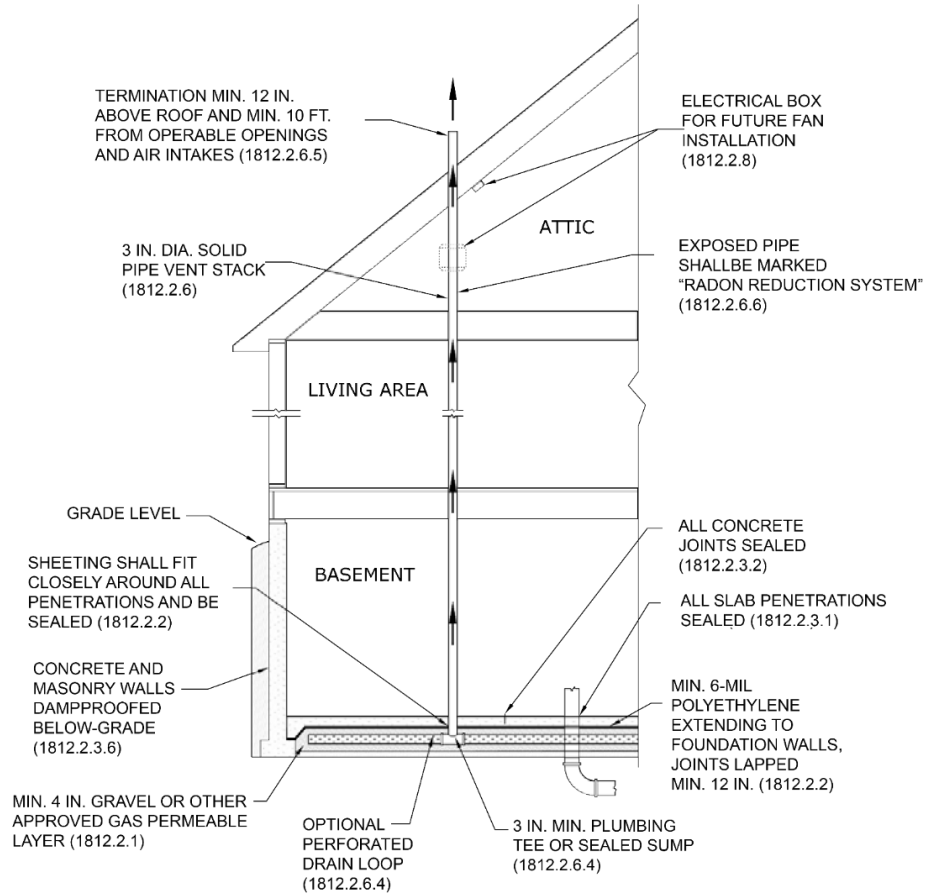


FIGURE 1812.2(1)
RADON-RESISTANT CONSTRUCTION FOR BASEMENT FOUNDATIONS

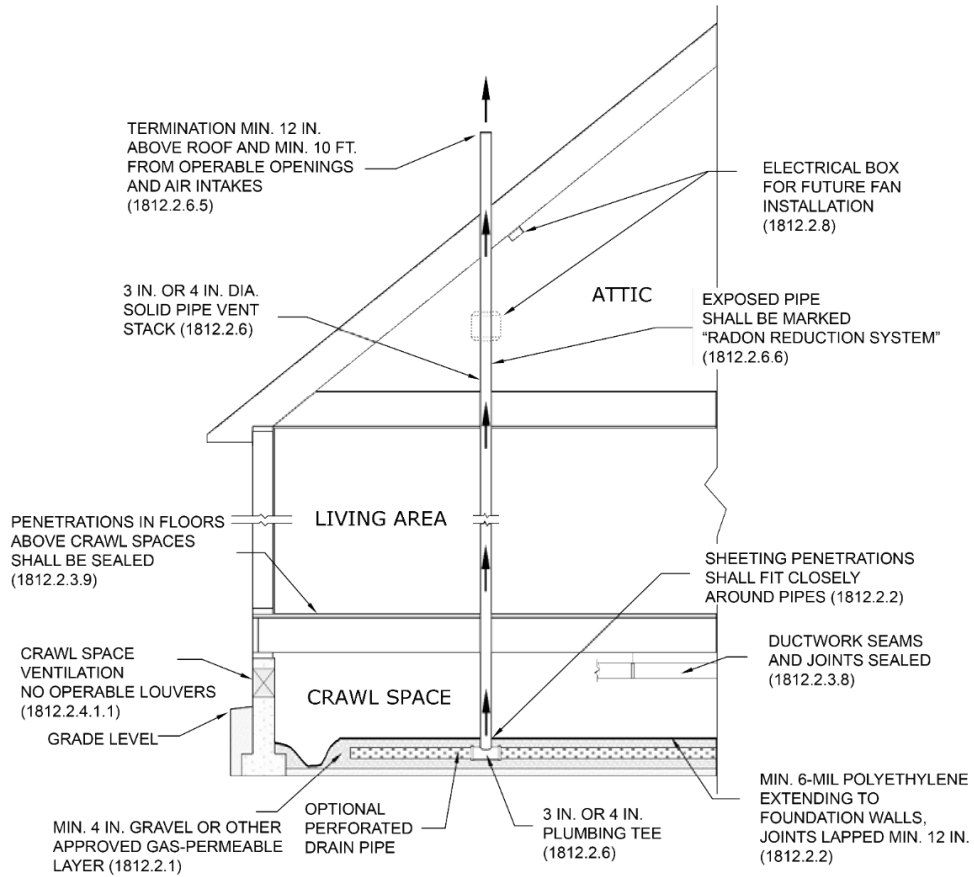


FIGURE 1812.2(3)
RADON-RESISTANT CONSTRUCTION FOR CRAWL SPACE FOUNDATIONS

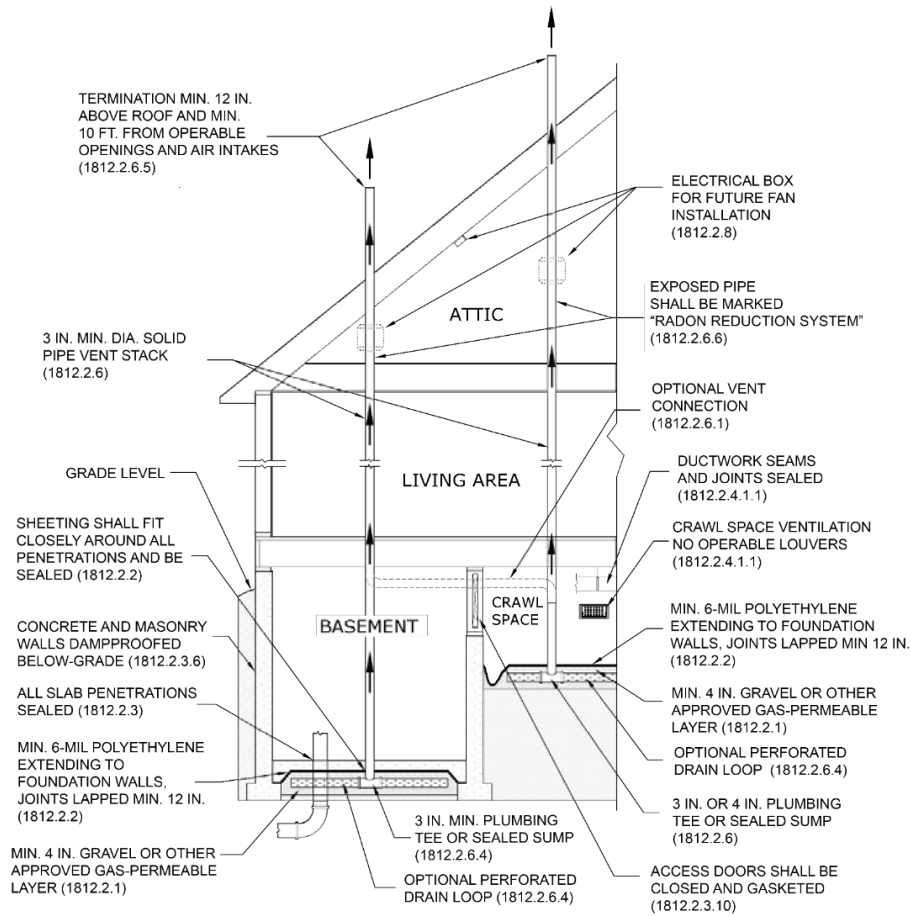


FIGURE 1812.2(2)
RADON-RESISTANT CONSTRUCTION FOR COMBINATION BASEMENT/CRAWL SPACE FOUNDATIONS

CHAPTER 19

CONCRETE

Section 1905 Modifications to ACI 318

- IBC 1905.1.1** **1905.1.1 ACI 318, Section 2.3.** Modify existing definitions and add the following definitions to ACI 318, Section 2.3. *(The rest of Section 1905.1.1 remains unchanged)*
- DETAILED PLAIN CONCRETE STRUCTURAL WALL.** A wall complying with the requirements of Chapter 14, including [Section 14.6.2](#) *as added by Section 1905.1.6*.
- IBC 1905.1.4** **1905.1.4 ACI 318, Section 18.11.** Modify ACI 318, Section 18.11.2.1 to read as follows:
- 18.11.2.1 – [Special structural walls constructed using precast concrete shall satisfy all the requirements of 18.10 for cast-in-place special structural walls in addition to 18.5.2, except 18.10.2.4 shall not apply for precast walls where deformation demands are concentrated at the panel joints.](#)
- IBC 1905.1.8** **1905.1.8 ACI 318, Section ~~17.10~~ ~~17.2.3~~.** Modify ACI 318 Sections 17.10.5.2, 17.10.5.3(d) and 17.10.6.2 to read as follows: *(The rest of Section 1905.1.8 remains unchanged)*

CHAPTER 21

MASONRY

Section 2101 General

- IBC 2101.2** **2101.2 Design methods.** Masonry shall comply with the provisions of TMS 402, TMS 403 or TMS 404 as well as applicable requirements of this chapter. Design loads shall be determined in accordance with Chapter 16.
- IBC 2101.3** **2101.3 Special inspection.** Where required, the special inspections and tests of masonry shall be in accordance with as defined in Chapter 17, or an itemized testing and inspection program shall be provided that meets or exceeds the requirements of Chapter 17.

Section 2103 Masonry Construction Materials

- IBC 2103.2.4** **2103.2.4 Mortar for adhered masonry veneer.** Mortar for use with *adhered masonry veneer* shall conform to ASTM C270 for Type N or S, or shall comply with ANSI A118.4 or A118.15 for ~~latex~~-modified ~~Portland-dry-set~~ cement mortar. The cementitious bond coat shall comply with ANSI A118.4 or A118.15.

Section 2104 Construction

- OSSC 2104.1.3** **2104.1.3 TMS 602, Articles 3.2 F, cleanouts.** Modify Article 3.2 F and 3.2 F.2 as follows:
- 3.2 F.** Provide cleanouts in bottom course of masonry for each grout pour where the grout pour height exceeds 5.33 feet (1625 mm).
- Exception:** The grout pour height requiring cleanouts may be increased where special approved construction procedures are used to keep the bottom and sides of the grout spaces clean and clear prior to grouting.
- 3.2 F.2.** Construct cleanouts with an opening of sufficient size to permit removal of debris. The minimum opening dimension shall be 3 inches (76.2 mm).
- Cleanout constructed with an opening height of 1¹/₈ inches (28.58 mm) plus ³/₈-inch (9.5 mm) mortar bed joint thickness [1¹/₂ inches (38.1 mm) total height] and an opening width of 4¹/₄ inches (108 mm) in length shall be permitted.

Section 2107 Allowable Stress Design

- IBC 2107.2.1** **2107.2.1 Lap splices.** The minimum length of lap splices for reinforcing bars in tension or compression, l_d , shall be:
- $l_d = 0.002db f_s$ **(Equation 21-1)**
- For SI: $l_d = 0.29db f_s$
- but not less than 12 inches (305 mm) and need not be greater than $72d_b$. The length of the lapped splice shall be not less than 40 bar diameters.
- (The rest of Section 2107.2.1 remains unchanged)*

Section 2109 Empirical Design of Adobe Masonry

- IBC 2109.2.4.8.2** **2109.2.4.8.2 Vapor permeance.** Plaster and finish assemblies shall have a vapor permeance of not less than 5 perms.
- Exception:** Insulation products applied to the exterior of *stabilized adobe* masonry walls in Climate Zones ~~2B, 3B, 4B and 5B~~ shall not have a vapor permeance requirement.

CHAPTER 22

STEEL

Section 2209 Steel Storage Racks

IBC 2209.3 **2209.3 Inspection Certification.** For rack storage structures that are 8 feet (2438 mm) in height or greater to the top *load* level and assigned to *Seismic Design Category* D, E, or F, special inspections shall be provided in accordance with Section 1705.13.7. ~~at completion of the storage rack installation, a certificate of compliance shall be submitted to the owner or the owner's authorized agent stating that the work was performed in accordance with approved construction documents.~~

CHAPTER 23

WOOD

Section 2304 General Construction Requirements

IBC 2304.11.4.1 **2304.11.4.1 Cross-laminated timber roofs.** *Cross-laminated timber roofs shall be not less than 3 inches (76 mm) nominal in actual thickness and shall be continuous from support to support and mechanically fastened to one another.*

IBC Table 2304.10.2

TABLE 2304.10.2 FASTENING SCHEDULE


DESCRIPTION OF BUILDING ELEMENTS	NUMBER AND TYPE OF FASTENER ^a	SPACING AND LOCATION	
Wood structural panels (WSP), subfloor, roof and interior wall sheathing to framing and particleboard wall sheathing to framing^a			
		Edges (inches)	Intermediate supports (inches)
31. ¹⁹ / ₃₂ " – ³ / ₄ "	8d common (2½" × 0.131"); or deformed (2" × 0.113") (subfloor and wall)	6	12
	8d common or deformed (2½" × 0.131" × 0.281" head) (roof) or RSR5-01 (2 ³ / ₈ " × 0.113") nail (roof) ^d	6 ^e	6 ^e
	2 ³ / ₈ " × 0.113" × 0.266" head nail; or 2" 16 gage staple, ⁷ / ₁₆ " crown (subfloor and wall)	4	8

(Portions of Table 2308.6.3(1) not shown remain unchanged)

Section 2308 Conventional Light-Frame Construction

IBC Table 2308.6.3(1)

TABLE 2308.6.3(1) BRACING METHODS

METHODS, MATERIAL	MINIMUM THICKNESS	FIGURE	CONNECTION CRITERIA ^a	
			Fasteners	Spacing
WSP Wood structural panel	3/8" in accordance with Table 2308.6.3(2) or 2308.6.3(3)		Table 2304.10.2 Exterior sheathing per Table 2304.6.1	6" edges 12" field
			Interior sheathing per Table 2304.10.1	Varies by fastener

(The other parts of Table 2308.6.3(1) remain unchanged)

CHAPTER 24

GLASS AND GLAZING

Section 2407 Glass in Handrails and Guards

IBC 2407.1.4 2407.1.4 Glazing in windborne debris regions. *Not adopted*

Section 2409 Glass in Walkways, Elevator Hoistways and Elevator Cars

IBC 2409.4 2409.4 Glass in elevator cars. Glass in elevator cars shall be in accordance with this section [and the Elevator Code](#).

CHAPTER 25 GYPSUM BOARD, GYPSUM PANEL PRODUCTS AND PLASTER

Section 2508 Gypsum Construction

IBC Table 2508.6

**TABLE 2508.6
SHEAR CAPACITY FOR HORIZONTAL WOOD-FRAME GYPSUM BOARD DIAPHRAGM CEILING ASSEMBLIES**

MATERIAL	THICKNESS OF MATERIAL (MINIMUM) (inches)	SPACING OF FRAMING MEMBERS (inches)	SHEAR VALUE ^{a, b} (PLF OF CEILING)	MINIMUM FASTENER SIZE
Gypsum board or gypsum panel product	1/2	16 o.c.	90	5d cooler or wallboard nail; 1 ⁵ / ₈ -inch long; 0.086-inch shank; ¹⁵ / ₆₄ -inch head ^c
Gypsum board or gypsum panel product	1/2	24 o.c.	70	5d cooler or wallboard nail; 1 ⁵ / ₈ -inch long; 0.086-inch shank; ¹⁵ / ₆₄ -inch head ^c

For SI: 1 inch = 25.4 mm, 1 pound per foot = 14.59 N/m.

- a. Values are not cumulative with other horizontal diaphragm values and are for short-term wind or seismic loading. Values shall be reduced 25 percent for normal loading.
- b. Values shall be reduced 50 percent in Seismic Design Categories D, E and F.
- c. 1¹/₄-inch, No. 6 Type S or W screws are permitted to be substituted for the listed nails. [1⁵/₈-inch, No. 6 Type S or W screws are permitted to be substituted for the listed nails where the material thickness is ⁵/₈-inch.](#)

CHAPTER 26 PLASTIC

Section 2603 Foam Plastic Insulation

IBC 2603.4.1.12 **2603.4.1.12 Interior signs.** Foam plastic used for interior signs in *covered mall buildings* in accordance with Section 402.6.4 shall be permitted without a thermal barrier. ~~Foam plastic signs that are not affixed to interior building surfaces shall comply with Chapter 8 of the *International Fire Code*.~~

Section 2611 Light-Transmitting Plastic Interior Signs

IBC 2611.1 **2611.1 General.** Light-transmitting plastic interior signs shall be limited as specified in Sections 2606 and 2611.2 through 2611.4. [See Section 101.2 for the scope of regulation for signs.](#)
Exception: Light-transmitting plastic interior wall signs in *covered and open mall buildings* shall comply with Section 402.6.4.

CHAPTER 27 ELECTRICAL

Section 2701 General

IBC 2701.1 **2701.1 Scope.** The provisions of this chapter and the Electrical Code ~~NFPA 70~~ shall govern the design, construction, erection and installation of the electrical components, appliances, equipment and systems used in buildings and structures covered by this code. The Electrical Code shall govern the design, installation, ~~the International Fire Code, the International Property Maintenance Code and NFPA 70 shall govern the use and maintenance of electrical components, appliances, equipment and systems. The International Existing Building Code and NFPA 70 shall govern the~~ alteration, repair, relocation, replacement and addition of electrical components, appliances, or equipment and systems.

Section 2702 Emergency and Standby Power Systems

IBC 2702.1.8 **2702.1.8 Group I-2 occupancies.** In Group I-2 occupancies located in *flood hazard areas* established by the flood plain administrator in accordance with ~~in~~ Section 1612.3, where new essential electrical systems are installed, and where new essential electrical system generators are installed, the systems and generators shall be located and installed in accordance with ASCE 24. Where connections for hookup of temporary generators are provided, the connections shall be located at or above the elevation required in ASCE 24.

IBC 2702.2.15 **2702.2.15 Membrane structures.** Standby power shall be provided for auxiliary inflation systems in permanent membrane structures as required in Section 3102.8.2. Standby power shall be provided for a duration of not less than 4 hours. ~~Auxiliary inflation systems in temporary air-supported and air-inflated membrane structures shall be provided in accordance with Section 3103.10.4 of the International Fire Code.~~

IBC 2702.3 **2702.3 Critical circuits.** Required critical circuits shall be installed and protected in accordance with the Electrical Code and provide a fire-resistance rating of not less than 1 hour.

~~using one of the following methods:~~

- ~~1. Cables, used for survivability of required critical circuits, that are listed in accordance with UL 2196 and have a fire resistance rating of not less than 1 hour.~~
- ~~2. Electrical circuit protective systems having a fire resistance rating of not less than 1 hour. Electrical circuit protective systems are installed in accordance with their listing requirements.~~
- ~~3. Construction having a fire resistance rating of not less than 1 hour.~~

IBC 2702.4 **2702.4 Maintenance.** *Not adopted*

Section 2703 Electrical Room Signage

OSSC 2703.1 **2703.1 Labeling.** Doors into electrical control panel rooms shall be marked with a plainly visible and legible sign stating "ELECTRICAL ROOM" or similar approved wording.

CHAPTER 28

MECHANICAL SYSTEMS

Section 2802 Fuel Oil Storage Systems

OSSC 2802

2802.1 Fuel oil storage systems. Fuel oil storage systems shall be installed in accordance with this code. Fuel oil piping systems shall be installed in accordance with the *Mechanical Code*.

2802.1.1 Fuel oil storage inside buildings. Fuel oil storage inside buildings shall comply with Section 444 or Sections 2802.1.1.1 through 2802.1.1.7.

2802.1.1.1 Quantity limits. One or more fuel oil storage tanks containing Class II or III *combustible liquid* shall be permitted in a building. The aggregate capacity of all tanks shall not exceed the following:

1. 660 gallons (2498 L) in unsprinklered buildings, where stored in a tank complying with UL 80, UL 142 or UL 2085.
2. 1,320 gallons (4997 L) in buildings equipped with an *automatic sprinkler system* in accordance with Section 903.3.1.1, where stored in a tank complying with UL 142. The tank shall be *listed* as a secondary containment tank, and the secondary containment shall be monitored visually or automatically.
3. 3,000 gallons (11,356 L) in buildings equipped with an automatic sprinkler system in accordance with Section 903.3.1.1, where stored in protected above-ground tanks complying with UL 2085 and Section 444.4.1.7.5. The tank shall be *listed* as a secondary containment tank, as required by UL 2085, and the secondary containment shall be monitored visually or automatically.

2802.1.1.2 Restricted use and connection. Tanks installed in accordance with Section 2802.1.1 shall be used to supply only fuel oil to fuel-burning equipment, generators or fire pumps installed in accordance with Section 2802.1.1. Connections between tanks and equipment supplied by such tanks shall be made using closed piping systems in accordance with the *Mechanical Code*.

2802.1.1.3 Applicability of maximum allowable quantity and control area requirements. The quantity of *combustible liquid* stored in tanks complying with Section 2802.1.1 shall not be counted toward the maximum allowable quantity set forth in Table 307.1(1), and such tanks shall not be required to be located in a *control area*.

2802.1.1.4 Installation. Tanks and piping systems shall be installed in accordance with Section 915 and Chapter 13, both of the *Mechanical Code*, as applicable.

2802.1.1.5 Separation. Rooms containing fuel oil tanks for internal combustion engines shall be separated from the remainder of the building by *fire barriers, horizontal assemblies*, or both, with a minimum 1-hour fire-resistance rating with 1-hour fire-protection-rated *opening protectives* constructed in accordance with this code.

Exception: Rooms containing protected aboveground tanks complying with Section 444.4.1.7.5 shall not be required to be separated from surrounding areas.

2802.1.1.6 Spill containment. Tanks exceeding 60 gallon (227 L) capacity or an aggregate capacity of 1,000 gallons (3785 L) that are not provided with integral secondary containment shall be provided with spill containment sized to contain a release from the largest tank.

2802.1.1.7 Tanks in basements. Tanks in *basements* shall be located not more than two stories below grade plane.

2802.2 Emergency signs. Refrigeration units or systems having a *refrigerant* circuit containing more than 220 pounds (100 kg) of Group A1 or 30 pounds (14 kg) of any other group *refrigerant* shall be provided with *approved* emergency signs, charts and labels in accordance with NFPA 704. Hazard signs shall be in accordance with the *Mechanical Code* for the classification of *refrigerants* listed therein.

2802.3 Refrigerant detection. Machinery rooms shall be provided with a *refrigerant* detector with an audible and visible alarm. Where ammonia is used as the *refrigerant*, detection shall comply with II.A.R. 2. For *refrigerants* other than ammonia, *refrigerant* detection shall comply with Section 2802.3.

2802.3.1 Refrigerants other than ammonia. A detector, or a sampling tube that draws air to a detector, shall be provided at an *approved* location where *refrigerant* from a leak is expected to accumulate. The system shall be designed to initiate audible and visible alarms inside and outside each entrance to the refrigerating machinery room and transmit a signal to an *approved* location where the concentration of *refrigerant* detected exceeds the lesser of the following:

1. The corresponding TLV-TWA values provided in the *Mechanical Code* for the *refrigerant* classification.
2. Twenty-five percent of the *lower flammable limit (LFL)*.

Detection of a *refrigerant* concentration exceeding the upper detection limit or 25 percent of the *lower flammable limit (LFL)*, whichever is lower, shall stop *refrigerant* equipment in the machinery room in accordance with Section 1106 of the *Mechanical Code*.

2802.4 Emergency pressure control system. Permanently installed *refrigeration systems* containing more than 6.6 pounds (3 kg) of flammable, *toxic* or *highly toxic refrigerant* or ammonia shall be provided with an emergency pressure control system in accordance with Sections 2802.4.1 and 2802.4.2.

2802.4.1 Automatic crossover valves. Each high- and intermediate-pressure zone in a *refrigeration system* shall be provided with a single automatic valve providing a crossover connection to a lower pressure zone. Automatic crossover valves shall comply with Sections 2802.4.1.1 through 2802.4.1.3.

2802.4.1.1 Overpressure limit set point. Automatic crossover valves shall be arranged to automatically relieve excess system pressure to a lower pressure zone if the pressure in a high- or intermediate-pressure zone rises to within 90 percent of the set point for emergency pressure relief devices.

2802.4.1.2 Manual operation. Where required by the *building official*, automatic crossover valves shall be capable of manual operation.

2802.4.1.3 System design pressure. *Refrigeration system* zones that are connected to a higher-pressure zone by an automatic crossover valve shall be designed to safely contain the maximum pressure that can be achieved by interconnection of the two zones.

2802.4.2 Automatic emergency stop. An automatic emergency stop feature shall be provided in accordance with Sections 2802.4.2.1 and 2802.4.2.2.

2802.4.2.1 Operation of an automatic crossover valve. Operation of an automatic crossover valve shall cause all compressors on the affected system to immediately stop. Dedicated pressure-sensing devices located immediately adjacent to crossover valves shall be permitted as a means for determining operation of a valve. To ensure that the automatic crossover valve system provides a redundant means of stopping compressors in an overpressure condition, high-pressure cutout sensors associated with compressors shall not be used as a basis for determining operation of a crossover valve.

2802.4.2.2 Overpressure in low-pressure zone. The lowest pressure zone in a *refrigeration system* shall be provided with a dedicated means of determining a rise in system pressure to within 90 percent of the set point for emergency pressure relief devices. Activation of the overpressure sensing device shall cause all compressors on the affected system to immediately stop.

2802.5 Discharge and termination of pressure relief and purge systems. Pressure relief devices, fusible plugs and purge systems discharging to the atmosphere from *refrigeration systems* containing *flammable, toxic or highly toxic refrigerants* or ammonia shall comply with Sections 2802.5.1 through 2802.5.7.

2802.5.1 Fusible plugs and rupture members. Discharge piping and devices connected to the discharge side of a fusible plug or rupture member shall have provisions to prevent plugging the pipe in the event the fusible plug or rupture member functions.

2802.5.2 Flammable refrigerants. Systems containing more than 6.6 pounds (3 kg) of flammable *refrigerants* having a density equal to or greater than the density of air shall discharge vapor to the atmosphere only through an *approved* treatment system in accordance with Section 2802.5.5 or a flaring system in accordance with Section 2802.5.6. Systems containing more than 6.6 pounds (3 kg) of flammable *refrigerants* having a density less than the density of air shall be permitted to discharge vapor to the atmosphere provided that the point of discharge is located outside of the structure at not less than 15 feet (4572 mm) above the adjoining grade level and not less than 20 feet (6096 mm) from any window, *ventilation* opening or *exit*.

2802.5.3 Toxic and highly toxic refrigerants. Systems containing more than 6.6 pounds (3 kg) of *toxic or highly toxic refrigerants* shall discharge vapor to the atmosphere only through an *approved* treatment system in accordance with Section 2802.5.5 or a flaring system in accordance with Section 2802.5.6.

2802.5.4 Ammonia refrigerant. Systems containing more than 6.6 pounds (3 kg) of ammonia *refrigerant* shall discharge vapor to the atmosphere in accordance with one of the following methods:

1. Directly, where the *building official* determines, on review of an engineering analysis, that a fire, health or environmental hazard would not result from atmospheric discharge of ammonia. The engineering analysis shall be prepared without charge to the *municipality*, by a qualified engineer, specialist, laboratory or safety specialty organization acceptable to the *building official*. The analysis shall be prepared by and bear the stamp of a *registered design professional*.
2. Through an *approved* treatment system in accordance with Section 2802.5.5. Through a flaring system in accordance with Section 2802.5.6.
4. Through an *approved* ammonia diffusion system in accordance with Section 2802.5.7.
5. By other *approved* means.

Exception: Ammonia/water absorption systems containing less than 22 pounds (10 kg) of ammonia and for which the ammonia circuit is located entirely outdoors.

2802.5.5 Treatment systems. Treatment systems shall be designed to reduce the allowable discharge concentration of the *refrigerant* gas to not more than 50 percent of the IDLH at the point of exhaust. Treatment systems shall be in accordance with Section 447.

2802.5.6 Flaring systems. Flaring systems for incineration of flammable *refrigerants* shall be designed to incinerate the entire discharge. The products of *refrigerant* incineration shall not pose health or environmental hazards. Incineration shall be automatic upon initiation of discharge, shall be designed to prevent blowback and shall not expose structures or materials to threat of fire. Standby fuel, such as LP-gas, and standby power shall have the capacity to operate for one and one-half the required time for complete incineration of *refrigerant* in the system. Standby electrical power, where required to complete the incineration process, shall be in accordance with Section 2702.

2802.5.7 Ammonia diffusion systems. Ammonia diffusion systems shall include a tank containing 1 gallon of water for each pound of ammonia (8.3 L of water for each 1 kg of ammonia) that will be released in 1 hour from the largest relief device connected to the discharge pipe. The water shall be prevented from freezing. The discharge pipe from the pressure relief device shall distribute ammonia in the bottom of the tank, but not lower than 33 feet (10,058 mm) below the maximum liquid level. The tank shall contain the volume of water and ammonia without overflowing.

2802.6 Mechanical ventilation exhaust. Exhaust from mechanical *ventilation* systems serving refrigeration machinery rooms containing *flammable, toxic or highly toxic refrigerants*, other than ammonia, capable of exceeding 25 percent of the LFL or 50 percent of the IDLH shall be equipped with *approved* treatment systems to reduce the discharge concentrations to those values or lower.

Exception: *Refrigeration systems* containing Group A2L complying with Section 2802.8.

2802.7 Electrical equipment. Where *refrigerant* of Groups A2, A3, B2 and B3, as defined in the *Mechanical Code*, are used, refrigeration machinery rooms shall conform to the Class I, Division 2 hazardous location classification requirements of the *Electrical Code*.

Exception:

1. Ammonia machinery rooms that are provided with *ventilation* in accordance with Section 1106.3 of the *Mechanical Code*.
2. Machinery rooms for systems containing Group A2L *refrigerants* that are provided with *ventilation* in accordance with Section 2802.8.

2802.8 Special requirements for Group A2L refrigerant machinery rooms. Machinery rooms with systems containing Group A2L *refrigerants* that do not comply with the Class I, Division 2, hazardous location classification electrical requirements of the *Electrical Code*, as permitted by Section 2802.7, Exception 2, shall comply with Sections 2802.8.1 through 2802.8.3.

2802.8.1 Ventilation system activation. *Ventilation* shall be activated by the refrigerant detection system in the machinery room. Refrigerant detection shall be in accordance with Section 2802.3 and all of the following:

1. The detectors shall activate at or below a *refrigerant* concentration of 25 percent of the *LFL*.
2. Upon activation, the detection system shall activate the emergency *ventilation* system in Section 2802.8.3.
3. The detection, signaling and control circuits shall be supervised.

2802.8.2 Emergency ventilation system. An emergency *ventilation* system shall be provided at the minimum exhaust rate specified in ASHRAE 15 or Table 2802.8.2. Shut down of the emergency *ventilation* system shall be by manual means.

**TABLE 2802.8.2
MINIMUM EXHAUST RATE**

REFRIGERANT	Q (m ³ /sec)	Q (cfm)
R32	15.4	32,600
R143a	13.6	28,700
R444A	6.46	13,700
R444B	10.6	22,400
R445A	7.83	16,600
R446A	23.9	50,700
R447A	23.8	50,400
R451A	7.04	15,000
R451B	7.05	15,000
R1234yf	7.80	16,600
R1234ze(E)	5.92	12,600

2802.8.3 Emergency ventilation system discharge. The point of discharge to the atmosphere shall be located outside the structure at not less than 15 feet (4572 mm) above the adjoining grade level and not less than 20 feet (6096 mm) from any window, *ventilation* opening or exit.

CHAPTER 29 PLUMBING SYSTEMS

Section 2901 General

IBC 2901.1 **2901.1 Scope.** The provisions of this chapter ~~and the *International Plumbing Code*~~ shall govern the location, availability, signage and minimum number ~~design, construction, erection and installation~~ of plumbing fixtures ~~components, appliances, equipment and systems~~ used in *buildings* and structures covered by this code. Toilet and bathing rooms shall be constructed in accordance with Section 1209. The *Plumbing Code* shall govern the installation. ~~1210. Private sewage disposal systems shall conform to the *International Private Sewage Disposal Code*. The *International Fire Code*, the *International Property Maintenance Code* and the *International Plumbing Code* shall govern the use and maintenance of plumbing components, appliances, equipment and systems. The *International Existing Building Code* and the *International Plumbing Code* shall govern the alteration, repair, relocation, replacement and addition of plumbing components, *appliances, equipment* and systems.~~

Section 2902 Minimum Plumbing Facilities

IBC 2902.1 **2902.1 Minimum number of fixtures.** Plumbing fixtures shall be provided in the minimum number as shown in Table 2902.1 based on the actual use of the building or space. Uses not ~~specifically listed~~ ~~shown~~ in Table 2902.1 shall be considered individually by the building official code official ~~and shall reflect the use of the space being served by the fixtures.~~ The number of occupants shall be determined by this code.

IBC 2902.1.1 **2902.1.1 Fixture calculations.** To determine the *occupant load* of each sex, the total *occupant load* shall be divided in half. To determine the required number of fixtures, the fixture ratio or ratios for each fixture type shall be applied to the *occupant load* of each sex in accordance with Table 2902.1. Fractional numbers resulting from applying the fixture ratios of Table 2902.1 shall be rounded up to the next whole number. For calculations involving multiple occupancies, such fractional numbers for each occupancy shall first be summed and then rounded up to the next whole number.

Exceptions: (*Exceptions 1 and 3 remain unchanged*)

2. Where multiple-user facilities are designed to serve all genders, the minimum fixture count shall be calculated 100 percent, based on total *occupant load*. In such multiple-user user facilities, each fixture type shall be in accordance with ICC A117.1 ~~and each urinal that is provided shall be located in a stall.~~

IBC Table 2902.1

**TABLE 2902.1
MINIMUM NUMBER OF REQUIRED PLUMBING FIXTURES^a
(See Sections 2902.1.1 and 2902.2)**

No.	CLASSIFICATION	DESCRIPTION	WATER CLOSETS SEE SECTION 424.2 OF THE INTERNATIONAL PLUMBING CODE (Urinals may replace water closets at a ratio of 1 urinal per 2/3 water closet)		LAVATORIES		BATHTUBS/ SHOWERS	DRINKING FOUNTAINS ^b (SEE SECTION 410 OF THE INTERNATIONAL PLUMBING CODE)	OTHER
			Male	Female	Male	Female			
			1	Assembly ^f	Theaters and other buildings for the performing arts and motion pictures ^d	1 per 125			
Nightclubs, bars, taverns, dance halls and buildings for similar purposes ^d	1 per 40	1 per 40			1 per 75		—	1 per 500 1 per floor	1 service sink
Restaurants, banquet halls and food courts ^d	1 per 75	1 per 75			1 per 200		—	1 per 500 1 per floor	1 service sink
Casino gaming areas	1 per 100 for the first 400 and 1 per 250 for the remainder exceeding 400	1 per 50 for the first 400 and 1 per 150 for the remainder exceeding 400			1 per 250 for the first 750 and 1 per 500 for the remainder exceeding 750		—	1 per 1,000 1 per floor	1 service sink

**TABLE 2902.1—(continued)
MINIMUM NUMBER OF REQUIRED PLUMBING FIXTURES.
(See Sections 2902.1.1 and 2902.2)**

No.	CLASSIFICATION	DESCRIPTION	WATER CLOSETS <i>SEE SECTION 424.2 OF THE INTERNATIONAL PLUMBING CODE (Urinals may replace water closets at a ratio of 1 urinal per 2/3 water closet)</i>		LAVATORIES		BATHTUBS/ SHOWERS	DRINKING FOUNTAINS ^g <i>(SEE SECTION 410 OF THE INTERNATIONAL PLUMBING CODE)</i>	OTHER
			Male	Female	Male	Female			
1	Assembly ^f	Auditoriums without permanent seating, art galleries, exhibition halls, museums, lecture halls, libraries, arcades and gymnasiums ^d	1 per 125	1 per 65	1 per 200		—	1 per 500 <u>1 per floor</u>	1 service sink
		Passenger terminals and transportation facilities ^d	1 per 500	1 per 500	1 per 750		—	1 per 1,000 <u>1 per floor</u>	1 service sink
		Places of worship and other religious services <u>without fixed seating</u> ^d	<u>1 per 120</u>	<u>1 per 60</u>	<u>1 per 200</u>		—	1 per 1,000 <u>1 per floor</u>	1 service sink
		Places of worship and other religious services <u>with fixed seating</u> ^d	1 per 150	1 per 75	1 per 200		—	1 per 1,000 <u>1 per floor</u>	1 service sink
		Coliseums, arenas, skating rinks, pools and tennis courts for indoor sporting events and activities	1 per 75 for the first 1,500 and 1 per 120 for the remainder exceeding 1,500	1 per 40 for the first 1,520 and 1 per 60 for the remainder exceeding 1,520	1 per 200	1 per 150	—	1 per 1,000 <u>1 per floor</u>	1 service sink
		Stadiums, amusement parks, bleachers and grandstands for outdoor sporting events and activities ^f	1 per 75 for the first 1,500 and 1 per 120 for the remainder exceeding 1,500	1 per 40 for the first 1,520 and 1 per 60 for the remainder exceeding 1,520	1 per 200	1 per 150	—	1 per 1,000 <u>1 per floor</u>	1 service sink
2	Business ^f	Buildings for the transaction of business, professional services, other services involving merchandise, office buildings, banks, light industrial, ambulatory care and similar uses	1 per 25 for the first 50 and 1 per 50 for the remainder exceeding 50		1 per 40 for the first 80 and 1 per 80 for the remainder exceeding 80		—	1 per 100	1 service sink ^e
3	Educational	Educational facilities	1 per 50		1 per 50		—	1 per 100 <u>1 per floor</u>	1 service sink
4	Factory and industrial	Structures in which occupants are engaged in work fabricating, assembly or processing of products or materials	1 per 100		1 per 100		—	1 per 400	1 service sink
5	Institutional	Custodial care facilities	1 per 10		1 per 10		1 per 8	1 per 100	1 service sink
		Medical care recipients in hospitals and nursing homes ^b	1 per room ^c		1 per room ^c		1 per 15	1 per 100	1 service sink
		Employees in hospitals and nursing homes ^b	1 per 25		1 per 35		—	1 per 100	—
		Visitors in hospitals and nursing homes	1 per 75		1 per 100		—	1 per 500	—
		Prisons ^b	1 per cell		1 per cell		1 per 15	1 per 100	1 service sink
		Reformatories, detention centers and correctional centers ^b	1 per 15		1 per 15		1 per 15	1 per 100	1 service sink
		Employees in reformatories, detention centers and correctional centers ^b	1 per 25		1 per 35		—	1 per 100	—
		Adult day care and child day care	1 per 15		1 per 15		1	1 per 100	1 service sink

(continued)

TABLE 2902.1—continued
MINIMUM NUMBER OF REQUIRED PLUMBING FIXTURES^a
(See Sections 2902.1.1 and 2902.2)

No.	CLASSIFICATION	DESCRIPTION	WATER CLOSETS <i>SEE SECTION 424.2 OF THE INTERNATIONAL PLUMBING CODE (Urinals may replace water closets at a ratio of 1 urinal per 2/3 water closet)</i>		LAVATORIES		BATHTUBS/ SHOWERS	DRINKING FOUNTAINS ^a <i>(SEE SECTION 410 OF THE INTERNATIONAL PLUMBING CODE)</i>	OTHER
			Male	Female	Male	Female			
6	Mercantile	Retail stores, service stations, shops, salesrooms, markets and shopping centers	1 per 500		1 per 750		—	1 per 1,000	1 service sink
7	Residential	Hotels, motels, boarding houses (transient)	1 per sleeping unit		1 per sleeping unit		1 per sleeping unit	—	1 service sink
		Dormitories, fraternities, sororities and boarding houses (not transient)	1 per 10		1 per 10		1 per 8	1 per 100	1 service sink
		Apartment house	1 per dwelling unit		1 per dwelling unit		1 per dwelling unit	—	1 kitchen sink per dwelling unit; 1 automatic clothes washer connection per 20 dwelling units
		One- and two-family dwellings and lodging houses with five or fewer guestrooms	1 per dwelling unit		1 per 10		1 per dwelling unit	—	1 kitchen sink per dwelling unit; 1 automatic clothes washer connection per dwelling unit
		Congregate living facilities with 16 or fewer persons	1 per 10		1 per 10		1 per 8	1 per 100	1 service sink
8	Storage	Structures for the storage of goods, warehouses, storehouses and freight depots, low and moderate hazard	1 per 100		1 per 100		—	1 per 1,000	1 service sink

- a. The fixtures shown are based on one fixture being the minimum required for the number of persons indicated or any fraction of the number of persons indicated. The number of occupants shall be determined by this code.
- b. Toilet facilities for employees shall be separate from facilities for inmates or care recipients.
- c. A single-user toilet room with one water closet and one lavatory serving not more than two adjacent patient sleeping units shall be permitted, provided that each patient sleeping unit has direct access to the toilet room and provisions for privacy for the toilet room user are provided.
- d. The occupant load for seasonal outdoor seating and entertainment areas shall be included when determining the minimum number of facilities required.
- ~~e. For business and mercantile classifications with an occupant load of 15 or fewer, a service sink shall not be required.~~
- ~~f. The required number and type of plumbing fixtures for outdoor swimming pools shall be in accordance with Section 609 of the International Swimming Pool and Spa Code.~~
- e. A drinking fountain need not be provided in a drinking or dining establishment.
- f. Amenity spaces, leasing offices and storage spaces accessed only by the occupants of Group R-2 dwelling units and their guests, building leasing agents and their staff, or building maintenance personnel may be provided a single-user toilet room for up to the first 100 occupants.

IBC 2902.2 **2902.2 Separate facilities.** Where plumbing fixtures are required, separate facilities shall be provided for each sex.

Exceptions: *(Exception 1 and 3 remain unchanged)*

- 2. Separate facilities shall not be required in structures or tenant spaces with a total occupant load, including both employees and customers, of ~~30~~ 15 or fewer. One single-user toilet room shall be permitted.

4. Separate facilities shall not be required in business occupancies in which the maximum *occupant load*, including both employees and customers, is ~~25~~ 50 or fewer. One single-user toilet room shall be permitted.
5. Separate facilities shall not be required where the operational needs of a facility necessitate other approved configurations.
6. Separate facilities shall not be required to be designated by sex where single-user toilet rooms are provided in accordance with Section 2902.1.2.
7. Separate facilities shall not be required where rooms having both water closets and lavatory fixtures are designed for use by both sexes and ~~privacy water closet and urinal~~ privacy is installed in accordance with ~~Chapter 12-Section 405.3.4 of the International Plumbing Code~~. Urinals shall be located in an area visually separated from the remainder of the facility or each urinal that is provided shall be located in a stall.

IBC 2902.3 **2902.3 Employee and public toilet facilities.** For structures and tenant spaces intended for public utilization, customers, patrons and visitors shall be provided with public toilet facilities. Employees associated with structures and tenant spaces shall be provided with toilet facilities. The number of plumbing fixtures located within the required toilet facilities shall be provided in accordance with Section 2902 for all users. Employee toilet facilities shall be either separate or combined employee and public toilet facilities.

Exception: Public toilet facilities shall not be required for:

(Exception 1 and 2 remain unchanged)

3. Noncustomarily occupied structures with public access, where approved by the building official.

IBC 2902.3.3 **2902.3.3 Location of toilet facilities in occupancies other than malls.** In occupancies other than covered and *open mall buildings*, the required public and employee toilet facilities shall be located not more than one *story* above or below the space required to be provided with toilet facilities, and the path of travel to such facilities shall not exceed a distance of 500 feet (152 m).

Exceptions:

1. In Group B (other than dining and drinking establishments), F, H, M and S occupancies, toilet facilities may be located in an adjacent building on the same lot. The path of travel to such facilities shall not exceed a distance of 300 feet (91 440 mm) and shall be served by an accessible route.
2. The location and maximum distances of travel to required employee facilities in factory and industrial *occupancies* shall be permitted to exceed that required by this section, provided that the location and maximum distances of travel are *approved*.
3. The location and maximum distances of travel to required public and employee facilities in Group S *occupancies* shall be permitted to exceed that required by this section, provided that the location and maximum distances of travel are *approved*.

IBC 2902.4 **2902.4 Signage.** Required public facilities shall be provided with signs that designate the sex where separate facilities are as required, unless otherwise approved by the building official ~~Section 2902.2~~. Signs shall be readily visible and located near the entrance to each toilet facility. Signs for *accessible* toilet facilities shall comply with Section 1112.

2902.5 Drinking fountain location. *Not adopted*
2902.6 Small occupancies. *Not adopted*
2902.7 Service sink location. *Not adopted*

Section 2903 Installation of Fixtures

IBC 2903 **Installation of fixtures.** *Not adopted*

All the provisions in IBC Section 2903 are deleted.

CHAPTER 30

ELEVATORS AND CONVEYING SYSTEMS

Section 3001 General

- IBC 3001.2** **3001.2 Emergency elevator communication systems for the deaf...** *Not adopted*
- IBC 3001.3** **~~3001.2~~ ~~3001.3~~ Referenced standards.** Except as otherwise provided for in this code, the design, construction, installation, *alteration, repair* and maintenance of elevators and conveying systems and their components shall conform to the [Elevator Code adopted under OAR 918-400-0455 applicable standard specified in Table 3001.3 and ASCE 24 for construction in flood hazard areas established in Section 1612.3.](#)
- [All references to the adopted elevator safety standard, ASME A17.1, are governed by the Elevator Code. Inspections and plan review are performed only by inspectors authorized by the state. References to ASME A17.1 in this chapter are provided for clarification.](#)
- Table 3001.3 Elevators and conveying systems and components.** *Not adopted*
- IBC 3001.4** **~~3001.3~~ ~~3001.4~~ Accessibility.** Passenger elevators required to be *accessible* or to serve as part of an *accessible* means of egress shall comply with Sections 1009 and [the Elevator Code 1110.8.](#)
- IBC 3001.5** **~~3001.4~~ ~~3001.5~~ Change in use.** A change in use of an elevator from freight to passenger, passenger to freight, or from one freight class to another freight class shall comply with [the Elevator Code Section 8.7 of ASME A17.1/CSA B44.](#)

Section 3002 Hoistway Enclosures

- IBC 3002.5** **3002.5 Emergency doors.** Where an elevator is installed in a single blind hoistway or on the outside of a building, there shall be installed in the blind portion of the hoistway or blank face of the building, an emergency door in accordance with [the Elevator Code ASME A17.1/CSA B44.](#)
- IBC 3002.9** **3002.9 Plumbing and mechanical systems.** Plumbing and mechanical systems shall not be located in an elevator [shaft except as allowed by the Elevator Code hoistway enclosure.](#)
- Exception:** ~~Floor drains, sumps and sump pumps shall be permitted at the base of the hoistway enclosure provided that they are indirectly connected to the plumbing system.~~

Section 3003 Emergency Operations

- IBC 3003.1** **3003.1 Standby power.** In buildings and structures where standby power is required or furnished to operate an elevator, the operation shall be in accordance with Sections 3003.1.1 through 3003.1.4. [Elevators under standby power shall operate as required by the Elevator Code.](#)
- IBC 3003.1.3** **3003.1.3 Two or more elevators.** Where two or more elevators are controlled by a common operating system, all elevators shall automatically transfer to standby power within 60 seconds after failure of normal power where the standby power source is of sufficient capacity to operate all elevators at the same time. [The operation of all elevators shall comply with the Elevator Code](#) ~~Where the standby power source is not of sufficient capacity to operate all elevators at the same time, all elevators shall transfer to standby power in sequence, return to the designated landing and disconnect from the standby power source. After all elevators have been returned to the designated level, not less than one elevator shall remain operable from the standby power source.~~
- IBC 3003.2** **3003.2 Fire fighters' emergency operation.** Elevators shall be provided with Phase I emergency recall operation and Phase II emergency in-car operation in accordance with [the Elevator Code ASME A17.1/CSA B44.](#)

IBC 3003.3 **3003.3 Standardized fire service elevator keys.** All elevators shall be equipped to operate with a standardized fire service elevator key in accordance with the [Elevator International Fire Code](#).

Section 3004 Conveying Systems

IBC 3004.1 **3004.1 General.** Escalators, moving walks, conveyors, personnel hoists and material hoists shall comply with [the Elevator Code](#) ~~the provisions of Sections 3004.2 through 3004.4.~~

Section 3005 Machine Rooms

IBC 3005.1 **3005.1 Access.** An *approved* means of access shall be provided to elevator machine rooms, control rooms, control spaces and machinery spaces [as required by the Elevator Code](#).

Section 3007 Fire Service Access Elevator

IBC 3007.1 **3007.1 General.** Where required by Section 403.6.1, every floor above and including the lowest level of fire department vehicle access of the building shall be served by fire service access elevators complying with Sections 3007.1 through 3007.9. Except as modified in this section, fire service access elevators shall be installed in accordance with this chapter and [the Elevator Code](#) ~~ASME A17.1/CSA B44. (Exceptions remain unchanged)~~

IBC 3007.8.1 **3007.8.1 Protection of wiring or cables.** Wires or cables that are located outside of the elevator hoistway and machine room and that provide normal or standby power, control signals, communication with the car, lighting, heating, air conditioning, *ventilation* and fire-detecting systems to fire service access elevators shall be [installed and protected in accordance with the Electrical Code and provide a fire-resistance rating of not less than 2 hours.](#) ~~using one of the following methods:~~

- ~~1.— Cables used for survivability of required critical circuits shall be listed in accordance with UL 2196 and shall have a fire-resistance rating of not less than 2 hours.~~
- ~~2.— Electrical circuit protective systems shall have a fire-resistance rating of not less than 2 hours. Electrical circuit protective systems shall be installed in accordance with their listing requirements.~~
- ~~3.— Construction having a fire-resistance rating of not less than 2 hours.~~

Exception: Wiring and cables to control signals are not required to be protected provided that wiring and cables do not serve Phase II emergency in-car operations.

Section 3008 Occupant Evacuation Elevators

IBC 3008.1.3 **3008.1.3 Fire safety and evacuation plan.** *Not adopted.*

IBC 3008.1.4 **[3008.1.3](#) ~~3008.1.4~~ Operation.** The occupant evacuation elevators shall be used for occupant self-evacuation in accordance with the occupant evacuation operation requirements in [the Elevator Code](#) ~~ASME A17.1/CSA B44~~ and the building's fire safety and evacuation plan.

IBC 3008.6.4 **3008.6.4 Lobby size.** Each occupant evacuation elevator lobby shall have minimum floor area as follows:

(Items 1 and 2 remain unchanged)

Exception: The size of lobbies serving multiple banks of elevators shall have the minimum floor area *approved* on an individual basis ~~and shall be consistent with the building's fire safety and evacuation plan.~~

IBC 3008.7.1 **3008.7.1 Elevator recall.** The *fire command center* or an alternate location *approved* by the fire department shall be provided with the means to manually initiate a Phase I Emergency Recall of the occupant evacuation elevators in accordance with [the Elevator Code](#) ~~ASME A17.1/CSA B44.~~

IBC 3008.8.2 **3008.8.2 Protection of wiring or cables.** Wires or cables that are located outside of the elevator hoistway, machine room, control room and control space and that provide normal or standby power, control signals, communication with the car, lighting, heating, air conditioning, ventilation and fire-detecting systems to occupant evacuation elevators shall be installed and protected in accordance with the *Electrical Code* and provide a fire-resistance rating of not less than 2 hours.

~~using one of the following methods:~~

- ~~1.—Cables used for survivability of required critical circuits shall be listed in accordance with UL 2196 and shall have a fire-resistance rating of not less than 2 hours.~~
- ~~2.—Electrical circuit protective systems shall have a fire-resistance rating of not less than 2 hours. Electrical circuit protective systems shall be installed in accordance with their listing requirements.~~
- ~~3.—Construction having a fire-resistance rating of not less than 2 hours.~~

Exception: Wiring and cables to control signals are not required to be protected provided that wiring and cables do not serve Phase II emergency in-car operation.

CHAPTER 31

SPECIAL CONSTRUCTION

Section 3101 General

IBC 3101.1 **3101.1 Scope.** The provisions of this chapter shall govern regulated special building construction including membrane structures, temporary structures, *pedestrian walkways* and tunnels, automatic *vehicular gates, awnings* and *canopies, marquees*, signs, towers, antennas, swimming pool enclosures and barriers, solar energy systems and *intermodal shipping containers*. See Section 101.2 for the detailed scope of regulation.

Section 3102 Membrane Structures

OSSC 3102.3.2 **3102.3.2 Flame propagation performance testing and certification.** The owner or agent shall file with the building official a certificate provided by the product manufacturer to verify that the materials have been tested and certified by an approved testing laboratory. The certificate shall indicate that the floor coverings, tents, membrane structures and their appurtenances, which include sidewalls, drops and tarpaulins, are composed of materials meeting the flame propagation performance of Test Method 2 of NFPA 701. Additionally, it shall indicate that the bunting and combustible decorative materials and effects are composed of material meeting the flame propagation performance criteria of Test Method 1 or Test Method 2 of NFPA 701, as applicable. Alternatively, the materials shall be treated with a flame retardant in an approved manner and meet the flame propagation performance criteria of the applicable test method of NFPA 701. The certificate shall indicate compliance with the testing requirements of NFPA 701, Chapter 16. The flame propagation performance criteria shall be effective for the period specified by the permit.

3102.3.3 Label. Membrane structures or tents shall have a permanently affixed label bearing the following:

1. The identification of size and fabric or material.
2. The names and addresses of the manufacturers of the tent or air-supported structure.
3. A statement that the fabric or material meets the requirements of Section 3102.3.2.
4. If treated, the date the fabric or material was last treated with flame-retardant solution, the trade name or kind of chemical used in treatment, name of person or firm treating the fabric or material, and name of testing agency and test standard by which the fabric or material was tested.
5. If untreated, a statement that no treatment was applied when the fabric or material met the requirements of Section 3102.3.2.

OSSC 3102.9 **3102.9 Certification.** The certification required by Section 3102.3.2 shall contain all of the information specified in Section 3102.3.2.

3102.10 Combustible materials. Hay, straw, shavings or similar combustible materials shall not be located within any tent or membrane structure containing an assembly occupancy, except the materials necessary for the daily feeding and care of animals. Sawdust and shavings utilized for a public performance or exhibit shall not be prohibited provided that the sawdust and shavings are kept damp. Combustible materials shall not be permitted under stands or seats at any time.

3102.11 Smoking. Smoking shall not be permitted in tents or membrane structures. Approved "No Smoking" signs shall be conspicuously posted.

3102.12 Open or exposed flame. Open flame or other devices emitting flame, fire or heat or any flammable or combustible liquids, gas, charcoal or other cooking device or any other unapproved devices shall not be permitted inside the tent or membrane structure while open to the public unless approved by the building official.

3102.13 Spot lighting. Spot or effect lighting shall be only by electricity, and all combustible construction located within 6 feet (1829 mm) of such equipment shall be protected with *approved* noncombustible insulation not less than 9¹/₄ inches (235 mm) thick.

3102.14 Safety film. Motion pictures shall not be displayed in *tents* or *membrane structures* unless the motion picture film is safety film.

3102.15 Clearance. There shall be a clearance of not less than 3 feet (914 mm) between the fabric envelope and all contents located inside *membrane structures*.

3102.16 Occupant load factors. The *occupant load* allowed in an assembly structure, or portion thereof, shall be determined in accordance with Chapter 10.

3102.17 Heating and cooking equipment. Heating and cooking equipment shall be in accordance with Sections 3102.17.1 through 3102.17.7.

3102.17.1 Installation. Heating or cooking equipment, tanks, piping, hoses, fittings, valves, tubing and other related components shall be installed as specified in the *Mechanical Code* and shall be *approved* by the *building official*.

3102.17.2 Venting. Gas, liquid and solid fuel-burning equipment designed to be vented shall be vented to the outside air as specified in the *Mechanical Code*. Such vents shall be equipped with *approved* spark arresters where required.

Where vents or flues are used, all portions of the *tent* or *membrane structure* shall be not less than 12 inches (305 mm) from the flue or vent.

3102.17.3 Location. Cooking and heating equipment shall not be located within 10 feet (3048 mm) of *exits* or combustible materials.

3102.17.4 Cooking tents. *Tents* with sidewalls or drops where cooking is performed shall be separated from other *tents* or *membrane structures* by not less than 20 feet (6096 mm).

3102.17.5 Electrical heating and cooking equipment. Electrical heating and cooking equipment shall comply with the *Electrical Code*.

3102.17.6 LP-gas equipment. LP-gas equipment such as *containers*, tanks, piping, hoses, fittings, valves, tubing and other related components shall be *approved* and in accordance with this code.

3102.17.7 Flammable and combustible liquids. The storage of flammable and *combustible liquids* and the use of flammable-liquid-fueled equipment shall be in accordance with this code.

Section 3103 Temporary Structures

IBC 3103.1 **3103.1 General.** The provisions of Sections 3103.1 through 3103.4 shall apply to structures erected for a period of less than 180 days. Detached tents and other membrane structures erected for a period of less than 180 days are regulated by the fire official and not regulated by this section.

Section 3107 Signs

IBC 3107.1

See Section 101.2 for the scope of regulation for signs.

3107.1 General. Regulated signs shall be designed and constructed in accordance with this code.

Section 3108 Telecommunication and Broadcast Towers

IBC 3108

[See Section 101.2 for the scope of regulation for towers.](#)

3108.1 General. [Regulated](#) towers shall be designed and constructed in accordance with the provisions of TIA 222. Towers shall be designed for seismic loads; exceptions related to seismic design listed in Section 2.7.3 of TIA 222 shall not apply. In Section 2.6.6.2 of TIA 222, the horizontal extent of Topographic Category 2, escarpments, shall be 16 times the height of the escarpment.

Exception: Single free-standing poles used to support antennas not greater than 75 feet (22 860 mm), measured from the top of the pole to grade, shall not be required to be noncombustible.

3108.2 Location and access. [Regulated](#) towers shall be located such that guy wires and other accessories shall not cross or encroach on any street or other public space, or over above-ground electric utility lines, or encroach on any privately owned property without the written consent of the owner of the encroached-upon property, space or above-ground electric utility lines. Towers shall be equipped with climbing and working facilities in compliance with TIA 222. Access to the tower sites shall be limited as required by applicable OSHA, FCC and EPA regulations.

Section 3109 Swimming Pools, Spas And Hot Tubs

IBC 3109.1

3109.1 General. The design and construction of [barriers for residential](#) swimming pools [that are accessory to four or fewer dwelling units](#) shall comply with the *International Swimming Pool and Spa Code*. [Public swimming pools are not governed by this code. Please reference OAR Chapter 333, Division 60 concerning public swimming pools as promulgated by the Department of Human Services under the authority established in ORS Chapter 448.](#)

Section 3111 Solar Energy Systems

IBC 3111.1

3111.1 General. Solar energy systems shall comply with the requirements of this section.

3111.1.1 Wind resistance. Rooftop-mounted *photovoltaic panel systems* and solar thermal collectors shall be designed [for wind loads](#) in accordance with Section 1609.

[Wind loads for rooftop-mounted photovoltaic panels and modules and solar thermal collectors are permitted to be determined by wind tunnel tests in accordance with ASCE 7 Sections 31.6 and 31.7.](#)

Exception: [Installations that comply with the provisions of Section 3111.3.5.3.](#)

3111.1.2 Roof live load. Roof structures that provide support for solar energy systems shall be designed in accordance with Section 1607.14.4.

Exception: [Installations that comply with the provisions of Section 3111.3.5.3.](#)

IBC 3111.2

3111.2 Solar thermal systems. Solar thermal systems shall be designed and installed in accordance with this [code](#), the *Plumbing Code*, the *Mechanical Code* and the [manufacturer's installation instructions](#). Where light-transmitting plastic covers are used, solar thermal collectors shall be designed in accordance with Section 2606.12.

IBC 3111.3

3111.3 Photovoltaic solar energy systems. *Photovoltaic* solar energy systems shall be designed and installed in accordance with this [code](#), the [Electrical Code](#) and the *manufacturer's installation instructions*.

3111.3.1 Equipment. *Photovoltaic panels and modules* shall be *listed* and *labeled* in accordance with UL 1703 or with both UL 61730-1 and UL 61730-2. Inverters shall be *listed* and *labeled* in accordance with UL 1741. [Photovoltaic racking and associated attachment components shall comply with one of the following:](#)

1. Certified to UL 1703 by a nationally recognized testing laboratory and installed in accordance with the *manufacturer's installation instructions*.
2. Designed by a *registered design professional*.
3. Field evaluation by an *approved field evaluation firm*.
4. Approval by the *building official*.

3111.3.1.1 Corrosion resistance. All components of the *photovoltaic solar energy system* exposed to the weather shall be constructed of *approved corrosion-resistant materials*.

3111.3.2 Fire classification. Rooftop-mounted *photovoltaic panel systems* shall have noncombustible racking and mounting systems or have a fire classification in accordance with Section 1505.9. *Building-integrated photovoltaic (BIPV) systems* installed as *roof coverings* shall have a fire classification in accordance with Section 1505.8.

Exception: Detached one- and two-family *dwelling*s and *townhouses* classified as a Group R-3 or Group U occupancies are permitted to comply with the applicable provisions of the *Residential Code*.

3111.3.3 Building-integrated photovoltaic (BIPV) systems. *BIPV systems* installed as *roof coverings* shall be designed and installed in accordance with Section 1507.

Exception: Detached one- and two-family *dwelling*s and *townhouses* classified as a Group R-3 or Group U occupancies are permitted to comply with the applicable provisions of the *Residential Code*.

3111.3.4 Photovoltaic panel system location. The location of *photovoltaic* components, *racking*, support structures and attachments shall be in accordance with Sections 3111.3.4.1 through 3111.3.4.9.

3111.3.4.1 Zoning requirements. The installation of *photovoltaic panel systems* shall comply with the zoning requirements of the *municipality*.

3111.3.4.2 Flood hazard areas. The installation of *photovoltaic panel systems* within *flood hazard areas*, as established by the *flood plain administrator*, shall comply with this code.

Exception: Detached one- and two-family *dwelling*s and *townhouses* classified as a Group R-3 or Group U occupancies are permitted to comply with Section R322 of the *Residential Code*.

3111.3.4.3 Building egress. *Photovoltaic panel systems* shall not be installed in locations that would restrict or otherwise prevent the use of the required *means of egress* and *emergency escape and rescue openings*.

3111.3.4.4 Light and ventilation. *Photovoltaic panel systems* shall not be installed in locations that would restrict the required light or ventilation.

3111.3.4.5 Rooftop vent and drain clearances. *Photovoltaic panel systems* shall not be installed in locations that would restrict the function of plumbing or mechanical vents, skylights, drains or other rooftop features.

3111.3.4.6 Mechanical equipment clearances. *Photovoltaic panel systems* shall be installed with a clearance of not less than 30 inches (762 mm) around mechanical equipment requiring service or maintenance. The applicable provisions of the *Mechanical Code* and *Electrical Code* apply to installations of *photovoltaic panel systems*.

Exception: Detached one- and two-family *dwelling*s and *townhouses* classified as a Group R-3 or Group U occupancies, are permitted to comply with the applicable mechanical provisions of the *Residential Code*.

3111.3.4.7 Roof drainage. *Photovoltaic panel systems* shall not be installed in a manner that would obstruct roof drainage. Vertical *supports* or roof penetrations are not permitted within 12 inches (305 mm) of each side of the low point of the valley. The *photovoltaic modules* or *racking* are permitted to extend into the valley not more than 6 inches (152 mm) from the valley low point where a clearance of not less than 3 inches (76 mm) above the surface of the roof is provided.

3111.3.4.8 Fire fighter access and escape. To provide access and escape for fire fighters, the location of rooftop-mounted *photovoltaic modules* shall comply with the requirements of Section 3111.3.4.8.1 through 3111.3.4.8.5.2.

3111.3.4.8.1 Pathway requirements. All *photovoltaic* installations shall be provided with *pathways* not less than 36 inches (914 mm) in width along not less than three sides of the *solar roof plane*. The bottom edge of a roof plane with a slope greater than two units vertical in 12 units horizontal (2:12) shall not be used as a *pathway*. All *pathways* shall be located over a structurally supported area and measured from the edge of the roof and horizontal ridge to the *photovoltaic array* or any portion thereof.

Exceptions:

1. Structures with a *photovoltaic array* area of 1,000 square feet (92.90 m²) or less installed on a roof with a slope greater than two units vertical in 12 units horizontal (2:12) with an intersecting *adjacent roof plane* and where no dimension of the array is greater than 150 feet (45 720 mm) in length or width:
 - 1.1. Where the *photovoltaic array* does not exceed 25 percent, measured in plan view, of the total roof area of the structure, an unobstructed *pathway* not less than 12 inches (305 mm) shall be provided along each side of any horizontal ridge.
 - 1.2. Where the *photovoltaic array* exceeds 25 percent, measured in plan view, of the total roof area of the structure, an unobstructed *pathway* not less than 36 inches (914 mm) from ridge to eave over a structurally supported area shall be provided; in addition to an unobstructed *pathway* not less than 12 inches (305 mm) along each side of any horizontal ridge.
2. *Pathways* are not required on *nonoccupied accessory structures*, provided that they are separated from occupied structures by not less than 60 inches (3048 mm) or by a minimum two-hour fire-rated assembly.
3. *Townhouses* providing fire separation as required by the applicable code at the time of construction may be considered one structure and are permitted to comply with the provisions of Section 3111.3.4.8.1, Exception 1.1.

3111.3.4.8.2 Intermediate pathway locations. Roof planes that include a *photovoltaic array* greater than 150 feet (45 720 mm) in length or width shall have additional intermediate *pathways*.

For every 150 feet (45 720 mm) of *photovoltaic array*, including offset *photovoltaic modules* or angled installations, an intermediate *pathway* not less than 36 inches (914 mm) in width separating the *photovoltaic array*, shall be provided. The square footage of a *photovoltaic array* shall not exceed 22,500 square feet (2092 m²) without the installation of an intermediate *pathway*.

3111.3.4.8.2.1 Where required. Where a system is required to have intermediate *pathways*, all *pathways* shall have one or more *cutouts* located adjacent to the *pathway*. No point on the *pathway* shall be more than 25 feet (7620 mm) from a *cutout*.

3111.3.4.8.3 Prohibited pathway locations. *Pathways* shall not be located within 12 inches (305 mm) of the low point of a valley.

3111.3.4.8.4 Smoke and heat vents. Where smoke and heat vents have been installed in accordance with Chapter 9 and Section 435, a *pathway* not less than 36 inches (914 mm) in width shall be provided to and around each vent for fire department access, maintenance and testing of these vents.

3111.3.4.8.5 Electrical component location. Electrical components shall be located in accordance with Sections 3111.3.4.8.5.1 and 3111.3.4.8.5.2.

3111.3.4.8.5.1 Disconnects, J-boxes, combiner boxes or gutters. Disconnects, J-boxes, combiner boxes or gutters shall not be located in any required *pathway* or *cutout*.

3111.3.4.8.5.2 Raceways. Raceways on flat roofs that cross a required *pathway* shall be bridged to avoid tripping hazards. Raceways shall not be permitted in required *pathways* on roof slopes greater than two units vertical in 12 units horizontal (2:12) (17-percent slope).

3111.3.4.9 Alternate installations. In accordance with Section 104.10, an alternative material, design, location, method of construction, or means of safe fire fighter access and egress may be approved.

3111.3.5 Structural. *Photovoltaic components, racking, support structures and attachments shall be in accordance with the provisions of this section.*

3111.3.5.1 Photovoltaic module attachment. *Photovoltaic modules shall be attached in accordance with the manufacturer's installation instructions and to account for all loads, including dead loads, snow loads, wind loads and seismic loads, as prescribed by this code.*

3111.3.5.2 Photovoltaic racking. *Photovoltaic racking shall comply with Sections 3111.3.5.2.1 through 3111.3.5.2.3 or Section 3111.3.5.3.*

3111.3.5.2.1 Building penetrations. *All penetrations shall be flashed or sealed in a manner that prevents moisture from entering the wall and roof.*

3111.3.5.2.2 Structural support and attachment. *Photovoltaic racking and racking supports shall be positively attached to the structural components or blocking in accordance with this section. Photovoltaic racking and racking supports shall be installed in accordance with manufacturer's specifications or designed in accordance with this code and mounted in accordance with one of the following:*

1. Installed in accordance with manufacturer's installation instructions and designed in accordance with this code.
2. Positively attached to the structural components or blocking through the use of screws, bolts, J-bolts or other approved means. Such attachment shall not be accomplished by the use of toenails or nails subject to withdrawal. Photovoltaic racking and racking supports shall be mounted to structural components and shall not be attached to wall or roof coverings, trim or structural sheathing as a means of structural support.
3. Attached to standing seam metal roofs with connectors in accordance with manufacturer's installation instructions.
4. Certified nonpenetrating or minimally penetrating systems installed in accordance with the manufacturer's installation instructions.

3111.3.5.2.3 Rooftop-mounted photovoltaic racking. *Rooftop-mounted photovoltaic racking shall comply with Section 3111.3.1 and be designed in accordance with accepted engineering practice, and constructed and installed to safely support all loads, including dead loads, snow loads, wind loads and seismic loads as prescribed by this code.*

Exception: *Prescriptive installations complying with Section 3111.3.5.3.*

3111.3.5.3 Prescriptive installations. *Rooftop-mounted installations on Risk Category I or Risk Category II structures of conventional light-frame construction that comply with this section shall qualify as prescriptive and shall not require an engineered design where all of the following criteria are met:*

1. Structure requirements:

1.1. For other than detached one- and two-family dwellings and townhouses classified as Group R-3 and Group U occupancies, the following criteria shall be met:

1.1.1. The ground snow load, p_g , as determined by Section 1608, does not exceed 50 psf.

1.1.2. The wind exposure category, as determined by Section 1609.4, is Exposure Category B or C.

1.1.3. The basic design wind speed, V , as determined by Section 1609.3, does not exceed 120 mph for Exposure Category C sites or 135 mph for Exposure Category B sites.

1.1.4. Existing supporting roof framing is conventional light-frame construction with pre-engineered trusses or rafters spaced at not more than 24 inches (610 mm) on center.

1.1.5. Existing roof rafters and ceiling joists comply with Sections 2308.7.1, 2308.7.2 and 2308.7.3. Where rafter spans, as determined by Section 2308.7.2, are based on purlins provided between the ridge and eave, such purlins shall be supported by braces to bearing partitions in accordance with Section 2308.7.7 and Figure 3111.3.5.3.1(1). Where ceiling joists do not run parallel to rafters, rafters are tied across with rafter ties complying with Section 2308.7.3.1.

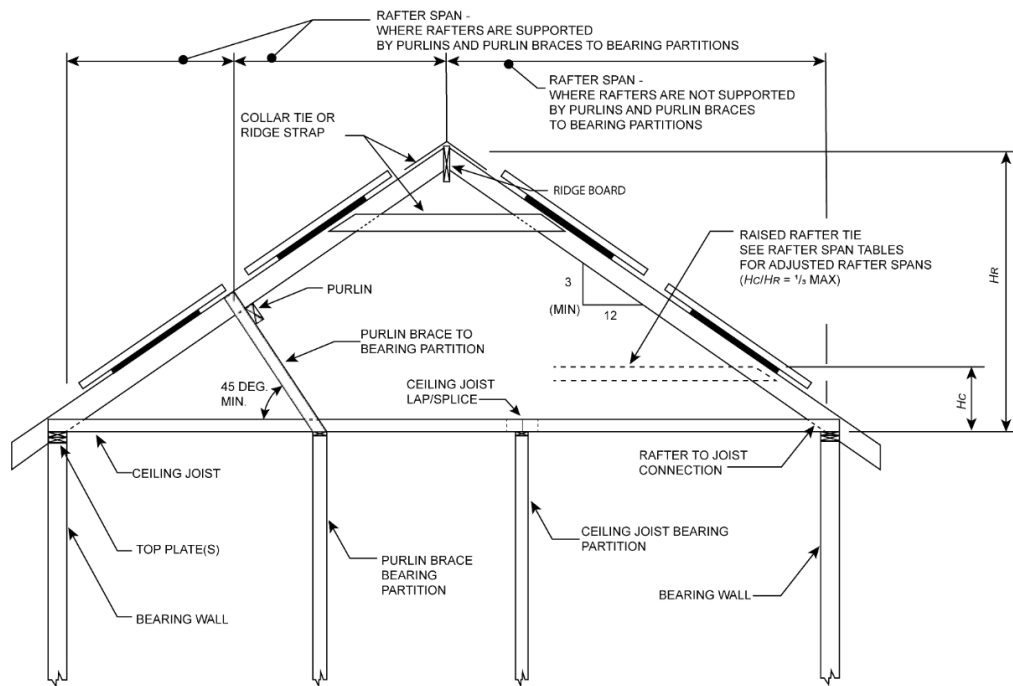
2.3.2. Shall be not more than 18 inches (457 mm) in width.

2.3.3. Shall be attached with a minimum of #10 screws at 24 inches (610 mm) on center.

2.3.4. Shall be installed over minimum ½-inch (12.7 mm) nominal wood structural panels attached to framing with 8d nails at 6 inches (153 mm) on center at panel edges and 12 inches (305 mm) on center field nailing.

6. Height: *Module* height above roof shall be not more than 18 inches (457 mm) from the top of the *module* to the roof surface and shall be in accordance with Figures 3111.3.5.3(2) and 3111.3.5.3(3).

7. Submittal requirement: *Construction documents* shall not be required where the *permit applicant* has demonstrated on a form approved by the State of Oregon, Building Codes Division, that the proposed installation complies with Section 3111.3.4.8 and this section.

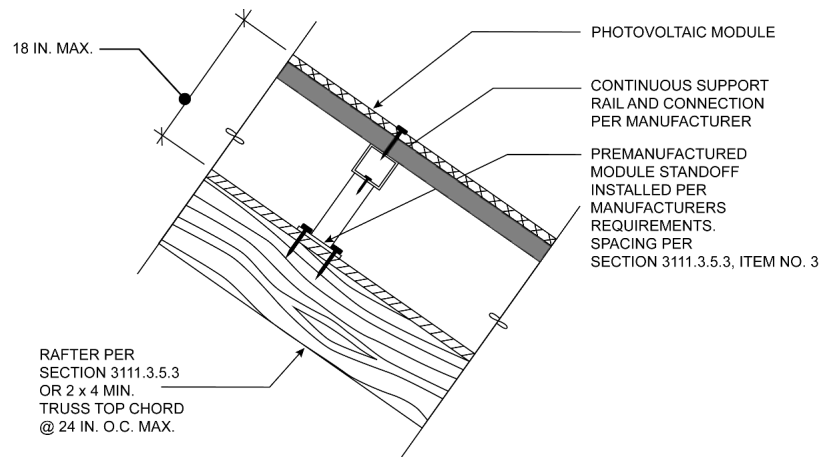


For SI: 1 inch = 25.4 mm, 1 foot = 305 mm, 1 degree = 0.018 rad.

H_c = Height of ceiling joists or rafter ties measured vertically above the top of rafter support walls.

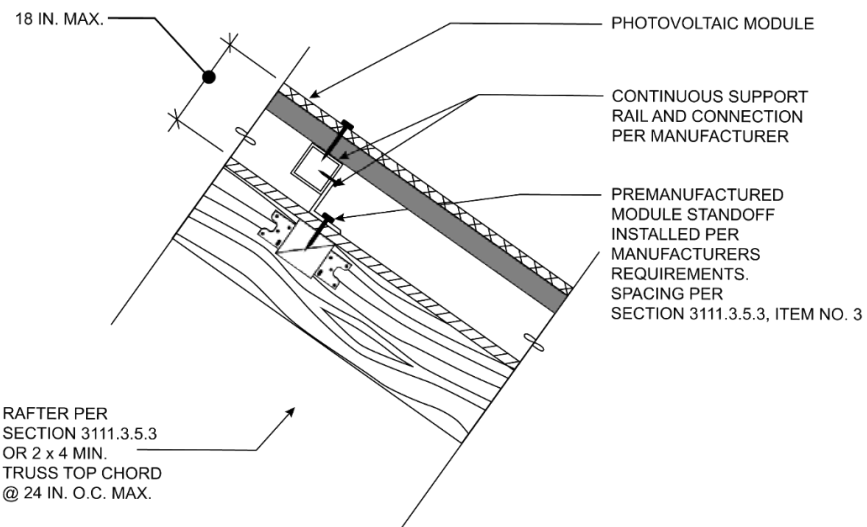
H_r = Height of roof ridge measured vertically above the top of rafter support walls.

FIGURE 3111.3.5.3(1)
BRACED ROOF RAFTERS FOR PRESCRIPTIVE ROOFTOP-MOUNTED PHOTOVOLTAIC PANEL SYSTEMS



For SI: 1 inch = 25.4 mm

FIGURE 3111.3.5.3(2)
PHOTOVOLTAIC RACKING AND MODULE ATTACHMENT TO RAFTERS OR TRUSSES



For SI: 1 inch = 25.4 mm

FIGURE 3111.3.5.3(3)
PHOTOVOLTAIC RACKING AND MODULE ATTACHMENT TO BLOCKING

OSSC 3111.4 **3111.4 Solar-ready.**

3111.4.1 Definitions. The following terms are defined in Chapter 2.

ADJACENT ROOF PLANE.

ROOF AREA.

SOLAR-READY ZONE.

TOTAL SOLAR RESOURCE FRACTION (TSRF).

3111.4.2 Solar-ready construction. Newly constructed buildings shall be provided with a solar-ready zone complying with Section 3111.4.1 through 3111.4.9.

Exceptions:

1. Group U occupancies.

2. A building with a permanently installed, on-site renewable energy system.
3. A building with a *Total Solar Resource Fraction (TSRF)* of less than 80 percent, as documented and submitted by the *registered design professional* and approved by the *building official*.
4. A building where the *registered design professional* submits documentation identifying that the *solar-ready zone* required by Section 3111.4.3 is infeasible because of structural configuration, extensive rooftop equipment, skylights, *vegetative roof* areas, other obstructions, or other unique design limitations, and where such documentation is *approved*.

3111.4.3 Solar-ready zone. A *solar-ready zone* shall be located on the roof of buildings that are oriented between 110 degrees and 270 degrees of true north or have low-slope roofs (roof slope < 2:12).

3111.4.4 Construction document requirements for solar-ready zones. Construction documents for *solar-ready zones* shall indicate all of the following:

1. The location and size of the *solar-ready zone*.
2. The future interconnection pathway and termination in accordance with Section 3111.4.8.
3. The location requirements, including but not limited to, future fire fighter access and escape pathways as required by Section 3111.3.4.
4. The structural design loads for roof *dead load* and roof *live load* in accordance with Section 3111.4.7.
5. Other data necessary to identify conformance.

3111.4.5 Solar-ready zone area. The total *solar-ready zone* area shall be not less than 40 percent of the *roof area* calculated as the horizontally projected gross *roof area* less the area covered by skylights, occupied roof decks, *vegetative roof* areas and mandatory access or set back areas as required by Section 3111.3.4. Where more than one *solar-ready zone* is identified, each zone shall be not less than 8 feet (2438 mm) in any dimension and be not less than 80 square feet (744 m²) in area.

3111.4.6 Obstructions. *Solar-ready zones* shall be free from obstructions, including, but not limited to, pipes, mechanical exhaust vents, ducts, HVAC equipment, required equipment clearances, skylights and rooftop-mounted equipment.

Exception: Plumbing vents are permitted to be located in the *solar-ready zone*.

3111.4.7 Roof loads and documentation. A collateral *dead load* of not less than 5 pounds per square foot (5 psf) (0.24 kN/m²) applied uniformly over the *solar-ready zone* shall be included in the gravity and seismic design calculations for the building.

3111.4.8 Interconnection pathway and termination. Construction documents for *solar-ready zones* shall indicate pathways for routing of conduit or piping, sized in accordance with the *Electrical Code*, from the *solar-ready zone* to an electrical service panel or other *approved location*.

3111.4.8.1 Reserved area at pathway termination. Construction documents shall indicate wall or floor area, or a combination thereof, intended to accommodate the future placement of inverters, meters, and similar equipment. This space shall be provided adjacent to the interconnection pathway termination location required by Section 3111.4.8.

3111.4.9 Electrical service reserved space. The main electrical service panel, or other *approved electrical panel* serving the *solar-ready zone*, shall have a reserved space to allow installation of a dual-pole circuit breaker for future solar electric and a dual-pole circuit breaker for future installation. These spaces shall be labeled "For Future Solar."

Section 3113 Temporary Special Event Structures

OSSC 3113 **3113.1 General.** Temporary special event structures shall comply with Sections 3102.3.1 through 3102.3.3.3, Sections 3113.2 through 3113.6 and ANSI E1.21.

3113.2 Approval. Temporary special event structures in excess of 400 square feet (37 m²) shall not be erected, operated or maintained for any purpose without first obtaining approval and a permit from the *building official*.

3113.3 Use period. Temporary special event structures erected in accordance with ANSI E1.21 shall not be erected for a period of more than six consecutive weeks.

3113.4 Required documents. The following documents shall be submitted to the *building official* for review before a permit is *approved*:

1. Construction documents: *Construction documents* shall be prepared by a *registered design professional* in accordance with this code and ANSI E1.21 where applicable. *Construction documents* shall include:

1.1. A summary sheet showing the building code used, design criteria, loads and support reactions.

1.2. Detailed construction and installation drawings.

1.3. Design calculations.

1.4. Operating limits of the structure explicitly outlined by the *registered design professional*, including environmental conditions and physical forces.

1.5. Effects of additive elements such as video walls, supported scenery, audio equipment, and vertical and horizontal coverings.

1.6. Means for adequate stability, including specific requirements for guying and cross-bracing, ground anchors or ballast for different ground conditions.

2. Designation of responsible party: The *owner* of the temporary special event structure shall designate in writing a person to have responsibility for the temporary special event structure on the site. The designated person shall have sufficient knowledge of the construction documents, manufacturer's recommendations and operations plan to make judgments regarding the structure's safety and to coordinate with the *building official*.

3. Operations plan: The operations plan shall reflect manufacturer's operational guidelines, procedures for environmental monitoring and actions to be taken under specified conditions consistent with the *construction documents*.

3113.5 Inspections. Inspections shall comply with Sections 110, 3113.5.1 and 3113.5.2.

3113.5.1 Independent inspector. The *owner* of a temporary special event structure shall employ a qualified, independent *approved agency* or individual to inspect the installation of a temporary special event structure.

3113.5.2 Inspection report. The inspecting agency or individual shall furnish an inspection report to the *building official*. The inspection report shall indicate that the temporary special event structure was inspected and was or was not installed in accordance with the approved *construction documents*. Discrepancies shall be brought to the immediate attention of the installer for correction. Where any discrepancy is not corrected, it shall be brought to the attention of the *building official* and the designated responsible party.

3113.6 Means of egress. The *means of egress* for temporary special event structures shall comply with Chapter 10.

CHAPTER 32

ENCROACHMENTS INTO THE PUBLIC RIGHT-OF-WAY

IBC 3201

The requirements of Chapter 32 are not adopted by the State of Oregon, Building Codes Division, as part of this code. Local *municipalities* may not regulate these matters under the authority of this code. A *municipality* may have authority outside of this code to regulate these matters locally, where not preempted.

The provisions of IBC Chapter 32 are deleted.

CHAPTER 33

SAFEGUARDS DURING CONSTRUCTION

Section 3301 General

IBC 3301.1 **3301.1 Scope.** The provisions of this chapter shall govern safety during construction ~~and the protection of adjacent public and private properties.~~

[Occupied and existing structures under state law related to building inspection programs.](#)

[Note: This information is provided for building official use and is not intended to provide direction to any other form of government outside of a building official operating under State of Oregon Building Codes Division's laws and rules. Questions regarding this information should be addressed through local counsel.](#)

[Under ORS 476.030 and Chapter 455, building officials are prohibited from requiring corrections or any changes to an existing structure that is maintained in conformity with the state building code regulations in effect at the time of construction. Under ORS Chapters 476 and 455, occupied structures that have no valid certificate of occupancy do not fall under the delegated authority from the State of Oregon, Building Codes Division. No state authority exists for building officials to access buildings or require corrections for structures unless a permit application is on file. References within the state building code that provide access and investigative authority to building officials are rescinded and are not valid.](#)

IBC 3301.2 **3301.2 Storage and placement.** *Not adopted*

IBC 3301.2.1 **3301.2.1 Structural and construction loads.** *Not adopted*

Section 3302 Construction Safeguards

IBC 3302.2 **3302.2 Manner of removal.** *Not adopted*

IBC 3302.3 **3302.3 Fire safety during construction.** *Not adopted*

Section 3303 Demolition

IBC 3303

[Consistent with the purpose and scope of application authorized in ORS 455.020, the requirements of Section 3303 of the IBC are not adopted by the State of Oregon, Building Codes Division, as part of this code.](#)

[Municipalities may not regulate these matters under the authority of this code. A municipality may have authority outside of this code to regulate these matters locally, where not preempted.](#)

(The provisions of IBC Section 3303 is deleted)

Section 3305 ~~Sanitary~~ Reserved

IBC 3305 *(The provisions of IBC Section 3305 is deleted)*

Section 3306 ~~Protection of Pedestrians~~ Reserved

IBC 3306 *(The provisions of IBC Section 3306 is deleted)*

Section 3307 Protection of Adjoining Property

IBC 3307

Consistent with the purpose and scope of application authorized in ORS 455.020, the requirements of Section 3307 of the IBC are not adopted by the State of Oregon, Building Codes Division, as part of this code.

Municipalities may not regulate these matters under the authority of this code. A municipality may have authority outside of this code to regulate these matters locally, where not preempted.

(The provisions of IBC Section 3307 is deleted)

Section 3308 Temporary Use of Streets, Alleys and Public Property

IBC 3308

Consistent with the purpose and scope of application authorized in ORS 455.020, the requirements of Section 3308 of the IBC are not adopted by the State of Oregon, Building Codes Division, as part of this code.

Municipalities may not regulate these matters under the authority of this code. A municipality may have authority outside of this code to regulate these matters locally, where not preempted.

(The provisions of IBC Section 3308 is deleted)

Section 3309 Fire Extinguishers

IBC 3309

Consistent with the purpose and scope of application authorized in ORS 455.020, the requirements of Section 3309 of the IBC are not adopted by the State of Oregon, Building Codes Division, as part of this code.

Municipalities may not regulate these matters under the authority of this code. A municipality may have authority outside of this code to regulate these matters locally, where not preempted.

(The provisions of IBC Section 3309 is deleted)

Section 3310 Means of Egress

IBC 3310.1

3310.1 Stairways required. Where building construction exceeds 40 feet (12 192 mm) in height above the lowest level of required fire department vehicle access, a temporary or permanent stairway shall be provided. As construction progresses, such stairway shall be extended to within one floor of the highest point of construction having secured decking or flooring.

IBC 3310.2

3310.2 Maintenance of means of egress. *Means of egress* and required *accessible means of egress* shall be maintained at all times during construction, ~~demolition,~~ remodeling or alterations and additions to any building. *(The exception remains unchanged)*

Section 3311 Standpipes

IBC 3311

Consistent with the purpose and scope of application authorized in ORS 455.020, only the installation and construction standards for standpipe hose connections are adopted by the State of Oregon as part of this code.

Standpipe hose connection locations shall be determined by the fire official.

(The provisions of IBC Section 3311 is deleted)

Section 3313 Water Supply for Fire Protection

IBC 3313

Consistent with the purpose and scope of application authorized in ORS 455.020, the requirements of Section 3313 are not adopted by the State of Oregon, Building Codes Division, as part of this code. Local municipalities may not regulate these matters under the authority of this code.

(The provisions of IBC Section 3313 is deleted)

Section 3314 Fire Watch During Construction

IBC 3314

Consistent with the purpose and scope of application authorized in ORS 455.020, the requirements of Section 3314 are not adopted by the State of Oregon, Building Codes Division, as part of this code. Local municipalities may not regulate these matters under the authority of this code.

(The provisions of IBC Section 3314 is deleted)

CHAPTER 34

EXISTING BUILDINGS

Section 3401 General

3401.1 Scope. The provisions of this [chapter](#) shall apply to the *repair, alteration, change of occupancy, addition* to and relocation of *existing buildings*.

3401.2 Purpose. The intent of this [chapter](#) is to provide flexibility to permit the use of alternative approaches to achieve compliance with minimum requirements to provide a reasonable level of safety, health, property protection and general welfare insofar as they are affected by the *repair, alteration, change of occupancy, addition* and relocation of *existing buildings*.

3401.3 Applicability. This [chapter](#) shall apply to the *repair, alteration, change of occupancy, addition* and relocation of *existing buildings*, regardless of occupancy, subject to the criteria of Sections [3401.3.1 through 3401.3.4](#).

3401.3.1 Buildings not previously occupied. A building or portion of a building that has not been previously occupied or used for its intended purpose, in accordance with the [code](#) in existence at the time of its completion, shall be permitted to comply with the provisions of the [code](#) in existence at the time of its original *permit* unless such *permit* has expired. Subsequent *permits* shall comply with [the requirements of this code](#) for new construction.

3401.3.2 Buildings previously occupied. The legal occupancy of any building existing on the date of adoption of this code shall be permitted to continue without change, except as is specifically covered in this code.

3401.3.3 Discontinued use and vacancy. [The continuation of a legal occupancy shall be permitted regardless of the length of vacancy or discontinuation of use provided such continuation is not subject to a required change of occupancy.](#)

3401.3.4 Change of occupancy. A building shall not be used or occupied in whole or in part, and a *change of occupancy* of a building or portion thereof shall not be made until the *building official* has issued a certificate of occupancy therefor as provided herein. Issuance of a certificate of occupancy shall not be construed as an approval of a violation of the provisions of this code or of other [laws. Discontinued use of a legal occupancy, in](#)

[accordance with Section 3401.3.3, shall not require issuance of a new certificate of occupancy upon continuation of the use. See Chapter 1 for certificate of occupancy requirements.](#)

3401.4 Correction of violations of other codes. *Repairs or alterations* mandated by any property, housing or fire safety maintenance code, or mandated by any [licensure rule adopted pursuant to law, and outside the scope and authority of the state building code](#), shall conform only to the requirements of that code, rule, ordinance or [licensure](#), and shall not be required to conform to this [chapter](#) unless the code requiring such *repair or alteration* so provides.

[Repairs and alterations shall require a permit where specified by this code. Nothing in this code limits a local municipality's ability to require application of its own ordinances, or to enforce its own ordinances unless preempted.](#)

3401.4.1 Permits required. Any owner or owner's authorized agent who intends to *repair*, add to, alter, relocate, or *change the occupancy* of a building shall first make application to the *building official* and obtain the required *permit*. [Any owner or owner's authorized agent who intends to repair an existing fire protection system or life safety system shall first notify the local building official and obtain any necessary building permit, where required by the municipality.](#)

3401.4.2 Emergency repairs. Where *repairs* must be performed in an emergency situation, the *permit* application shall be submitted within the next [five working business days](#) to the *building official*.

3401.5 Repairs. [Application or notice to the building official is not required for repairs to structures and items listed in Section 105.2, provided that such repairs do not include any of the following:](#)

- [1. The removal or cutting away of any wall, partition, floor, ceiling or portion thereof.](#)
- [2. The removal, modification or cutting of any structural beam or load-bearing support.](#)
- [3. The removal or change of any required means of egress elements or rearrangement of parts of a building that would affect the existing egress path.](#)
- [4. Any addition to, alteration of, replacement or relocation of any standpipe.](#)

Section 3402 Definitions

3402.1 General. [See Chapter 2 for defined terms.](#)

Section 3403 Provisions for All Compliance Methods

3403.1 Administration.

3403.1.1 Applicability. *The repair, alteration, change of occupancy, addition or relocation of all existing buildings shall comply with Section 3403.1.2, 3403.1.3 or 3403.1.4. The provisions of this section shall apply to all alterations, repairs, additions, relocation of structures and changes of occupancy regardless of compliance method.*

3403.1.1.1 Bleachers, grandstands and folding and telescopic seating. Existing bleachers, grandstands and folding and telescopic seating shall comply with ICC 300.

ICC 300 Sections 501.2, 502, 503 and 504 are not adopted.

3403.1.2 Repairs. *Repairs shall comply with the requirements of this section and Section 3404. Repairs to historic buildings need only comply with Section 3412.*

3403.1.3 Alteration, addition or change of occupancy. *The alteration, addition or change of occupancy of all existing buildings shall comply with this section and one of the methods listed in Section 3403.1.3.1, 3403.1.3.2 or 3403.1.3.3 as selected by the applicant. Sections 3403.1.3.1 through 3403.1.3.3 shall not be applied in combination with each other.*

Exception: Subject to the approval of the *building official*, alterations complying with the laws in existence at the time the *building* or the affected portion of the *building* was built shall be considered in compliance with the provisions of this *chapter*. New structural members added as part of the *alteration* shall comply with the requirements of this code for new construction. This exception shall not apply to the following:

1. *Alterations* for accessibility required by Section 3403.6.
2. *Alterations* that constitute *substantial improvement* in *flood hazard areas*, established by the flood plain administrator, which shall comply with Sections 3405.3.2, 3407.1.3 or 3413.1.3.1.
3. Structural provisions of Sections 3403.4, 3405, 3407.6, 3408.5 and 3409.6.

3403.1.3.1 Prescriptive compliance method. *Alterations, additions and changes of occupancy complying with Section 3405 shall be considered in compliance with the provisions of this chapter.*

3403.1.3.2 Work area compliance method. *Alterations, additions and changes of occupancy complying with the applicable requirements of Sections 3406 through 3412 shall be considered in compliance with the provisions of this chapter.*

3403.1.3.3 Performance compliance method. *Alterations, additions and changes of occupancy complying with Section 3413 shall be considered in compliance with the provisions of this chapter.*

3403.1.4 Relocated buildings. Relocated buildings shall comply with ORS 455.410.

ORS 455.410 is not part of this code but is reprinted here for the reader's convenience:

455.410 Relocated buildings; substantial compliance required; permits. (1) Existing buildings or structures which are removed from their foundation and relocated to another site within this state shall be in substantial compliance as defined in subsections (2) and (3) of this section.

(2) "Substantial compliance" means compliance with local construction codes in effect as of the original permit date of the building or structure, or where there was no permitting required at the time of original construction, with basic health and safety standards, as described in the closest dated Uniform Housing Code, as published by the International Conference of Building Officials as of the date of construction. Only the insulation, overhead and underneath the structure, shall be upgraded to the current insulation requirements of the state building code, or to the maximum extent possible subject to the design of the structure. Nothing in this statute shall be construed to mean that all heating, plumbing and electrical systems shall be replaced with systems meeting current standards for new construction, except that any life-threatening deficiencies in those systems shall be repaired, notwithstanding that the cost of rehabilitation may exceed 50 percent of the value of the structure before rehabilitation.

(3) All foundation and basement construction on the structure and any remodeling at the new location shall be constructed subject to all applicable local current building and safety codes, or where none exist, with the applicable standards as described in the Uniform Housing Code described in subsection (2) of this section.

(4) All moved houses shall be provided with either battery-operated or hard-wired smoke detection devices located in accordance with the provisions of the code.

(5) Nothing in this section is intended to permit any person to move a structure unless the person first consults the appropriate building inspection authority and obtains all required permits.

3403.2 General provisions.

3403.2.1 Dangerous conditions. The *building official* shall have the authority to require the elimination of conditions deemed *dangerous*.

3403.2.2 Additional codes. *Alterations, repairs, additions and changes of occupancy to existing buildings and structures shall comply with the provisions for alterations, repairs, additions and changes of occupancy, respectively, in this chapter and the Energy Code, Mechanical Code and Electrical Code.*

3403.2.2.1 Additional codes in health care. In existing Group I-2 occupancies, ambulatory health care facilities, outpatient clinics and hyperbaric facilities, alterations, repairs, additions and changes of occupancy to, or relocation of, existing buildings and structures shall also comply with the applicable provisions of NFPA 99 within the scope of this code.

3403.2.3 Existing materials. Materials already in use in a building in compliance with requirements or approvals in effect at the time of their erection or installation shall be permitted to remain in use unless determined by the [building official](#) to be *unsafe*.

3403.2.4 New and replacement materials. Except as otherwise required or permitted by this [chapter](#), materials permitted [by this code](#) for new construction shall be used. Like materials shall be permitted for *repairs* and *alterations*, provided that *unsafe* conditions are not created. *Hazardous materials* shall not be used where [the new construction provisions of this code do](#) not permit their use in buildings of similar occupancy, purpose and location.

3403.2.4.1 New structural members and connections. New structural members and connections shall comply with the [new construction provisions of this code for](#) buildings of similar structure, purpose and location.

Exception: Where alternative design criteria are specifically permitted [by this chapter](#).

3403.2.5 Occupancy and use. Where determining the appropriate application of the referenced sections of this [chapter](#), the occupancy and use of a building shall be determined in accordance with Chapter 3.

3403.3 Reserved.

3403.4 Structural design loads and evaluation and design procedures.

3403.4.1 Live loads. Where an *addition* or *alteration* does not result in increased design *live load*, existing gravity load-carrying structural elements shall be permitted to be evaluated and designed for *live loads approved* prior to the *addition* or *alteration*. If the *approved live load* is less than that required by Section 1607, the area designated for the nonconforming *live load* shall be posted with placards of *approved* design indicating the *approved live load*. Where the *addition* or *alteration* results in increased design *live load*, the *live load* required by Section 1607 shall be used.

3403.4.2 Reserved.

3403.4.3 Seismic evaluation and design procedures. Where required, seismic evaluation or design shall be based on the procedures and criteria in this section, regardless of which compliance method is used.

3403.4.3.1 Compliance with full seismic forces. Where compliance requires the use of full seismic forces, the criteria shall be in accordance with one of the following:

1. [The new construction provisions of this code using one hundred percent of the prescribed seismic forces.](#) Where the existing seismic force-resisting system is a type that can be designated as “Ordinary,” values of R , Ω_0 and C_d used for analysis in accordance with Chapter 16 shall be

those specified for structural systems classified as “Ordinary” in accordance with Table 12.2-1 of ASCE 7, unless it can be demonstrated that the structural system will provide performance equivalent to that of a “Detailed,” “Intermediate” or “Special” system.

2. ASCE 41, using a Tier 3 procedure and the two-level performance objective in [Table 3403.4.3.1](#) for the applicable *risk category*.

**TABLE 3403.4.3.1
PERFORMANCE OBJECTIVES FOR USE IN ASCE 41 FOR
COMPLIANCE WITH FULL SEISMIC FORCES**

RISK CATEGORY (Based on Table 1604.5)	STRUCTURAL PERFORMANCE LEVEL FOR USE WITH BSE-1N EARTHQUAKE HAZARD LEVEL	STRUCTURAL PERFORMANCE LEVEL FOR USE WITH BSE-2N EARTHQUAKE HAZARD LEVEL
I	Life Safety (S-3)	Collapse Prevention (S-5)
II	Life Safety (S-3)	Collapse Prevention (S-5)
III	Damage Control (S-2)	Limited Safety (S-4)
IV	Immediate Occupancy (S-1)	Life Safety (S-3)

3403.4.3.2 Compliance with reduced seismic forces. Where seismic evaluation and design [are](#) permitted to use reduced seismic forces, the criteria used shall be in accordance with one of the following:

1. The [new construction provisions of this code](#) using 75 percent of the prescribed forces. Values of R , Ω_0 and C_d used for analysis shall be as specified in Section [3403.4.3.1](#).
2. ASCE 41, using the performance objective in [Table 3403.4.3.2](#) for the applicable *risk category*.

3403.5 In-situ load tests.

3403.5.1 General. Where used, in-situ load tests shall be conducted in accordance with Section 1708.

3403.6 Accessibility for existing buildings.

3403.6.1 Scope. The provisions of Sections [3403.6.1 through 3403.6.16](#) apply to *repairs*, *change of occupancy*, *additions* and *alterations* to existing [affected buildings](#), [historic buildings](#), and [covered multifamily dwellings](#).

3403.6.2 Design. Buildings and *facilities* shall be designed and constructed to be accessible in accordance with this [chapter](#) and the *alteration* and *existing building* provisions in ICC A117.1, as applicable. [See Chapter 11 for scoping of ICC A117.1.](#)

3403.6.3 Prohibited reduction in accessibility. An *alteration* that decreases or has the effect of decreasing accessibility of a building, *facility* or element, thereof, below the requirements [of this code](#) for new construction at the time of the *alteration* is prohibited. The number of accessible elements need not exceed that required [by this code](#) for new construction at the time of *alteration*.

TABLE 3403.4.3.2
PERFORMANCE OBJECTIVES FOR USE IN ASCE 41 FOR COMPLIANCE WITH REDUCED SEISMIC FORCES

RISK CATEGORY (Based on Table 1604.5)	STRUCTURAL PERFORMANCE LEVEL FOR USE WITH BSE-1E EARTHQUAKE HAZARD LEVEL (See Note d)	STRUCTURAL PERFORMANCE LEVEL FOR USE WITH BSE-2E EARTHQUAKE HAZARD LEVEL (See Note e)
I	Life Safety (S-3). See Note a	Collapse Prevention (S-5)
II	Life Safety (S-3). See Note a	Collapse Prevention (S-5)
III	Damage Control (S-2). See Note a	Limited Safety (S-4). See Note b
IV	Immediate Occupancy (S-1)	Life Safety (S-3). See Note c

- a. For Risk Categories I, II and III, the Tier 1 and Tier 2 procedures need not be considered for the BSE-1E earthquake hazard level.
- b. For Risk Category III, the Tier 1 screening checklists shall be based on the Collapse Prevention, except that checklist statements using the Quick Check provisions shall be based on *MS*-factors that are the average of the values for Collapse Prevention and Life Safety.
- c. For Risk Category IV, the Tier 1 screening checklists shall be based on Collapse Prevention, except that checklist statements using the Quick Check provisions shall be based on *MS*-factors for Life Safety.
- d. The BSE-1E shall be taken in accordance with ASCE 41 except that the spectral acceleration at any period shall not be taken less than 75 percent of the BSE-1N.
- e. The BSE-2E shall be taken in accordance with ASCE 41 except that the spectral acceleration at any period shall not be taken less than 75 percent of the BSE-2N.

3403.6.4 Extent of application. An *alteration* of an existing *facility* shall not impose a requirement for greater accessibility than that which would be required for new construction.

3403.6.5 Change of occupancy. Existing buildings that undergo a *change of occupancy* shall comply with Section 3403.6.7. Unless additions or alterations are made to the building or facility, change of occupancy alone shall not require compliance with the provisions of Chapter 11.

Exception: Type B *dwelling* or *sleeping units* required by Section 1108 are not required to be provided in existing buildings and facilities undergoing a *change of occupancy* or *alteration*.

3403.6.6 Additions. Provisions for new construction shall apply to *additions*. An *addition* that affects the accessibility to, or contains an area of, a *primary function* shall comply with the requirements in Section 3403.6.7.1.

3403.6.7 Alterations. A *facility* that is altered shall comply with the applicable provisions in Chapter 11 and the applicable provisions of Sections 3403.6.7.1 through 3403.6.7.16, unless *technically infeasible*. Where compliance with this section is *technically infeasible*, the *alteration* shall provide access to the maximum extent technically feasible.

3403.6.7.1 Alterations affecting an area containing a primary function. Where an *alteration* affects the accessibility to or contains an area of *primary function*, the route to the *primary function* area shall be accessible. The *accessible route* to the *primary function* area shall include toilet facilities and drinking fountains serving the area of *primary function*.

Exceptions:

1. The costs of providing the *accessible route* to the *altered area* are not required to exceed 25 percent of the costs of the *alterations* affecting the area of *primary function*. See ORS 447.241.

2. This provision does not apply to *alterations* limited solely to windows, hardware, operating controls, electrical outlets and signs.
3. This provision does not apply to *alterations* limited solely to mechanical systems, electrical systems, installation or *alteration* of *fire protection systems* and abatement of *hazardous materials*.
4. This provision does not apply to *alterations* undertaken for the primary purpose of increasing the accessibility of a *facility*.
5. This provision does not apply to altered areas limited to Type B *dwelling* and *sleeping units*.

3403.6.7.2 Accessible means of egress. *Accessible means of egress* required by Chapter 10 are not required to be added in existing *facilities*.

3403.6.7.3 Alteration of Type A units. The *alteration* to Type A individually owned *dwelling units* within a Group R-2 occupancy shall be permitted to meet the provision for a Type B *dwelling unit*.

3403.6.7.4 Reserved.

3403.6.7.5 Entrances. Where an *alteration* includes *alterations* to an entrance that is not accessible, and the *facility* has an accessible entrance, the altered entrance is not required to be accessible unless required by Section 3403.6.7.1. Signs complying with Section 1112 shall be provided.

3403.6.7.6 Accessible route. Exterior *accessible routes*, including curb ramps located on an *affected building site*, shall be not less than 36 inches (914 mm) minimum in width.

3403.6.7.7 Elevators. Altered elements of existing elevators shall comply with the *Elevator Code*.

3403.6.7.8 Platform lifts. Platform (wheelchair) lifts installed in accordance with the *Elevator Code* shall be permitted as a component of an *accessible route*.

3403.6.7.9 Stairways and escalators in existing buildings. Where an escalator or stairway is added where none existed previously and major structural modifications are necessary for installation, an *accessible route* complying with Section 1104.4 is required between levels served by such escalator or stairway.

3403.6.7.10 Determination of number of units. Where Chapter 11 requires accessible *Type A* or *Type B* units and where such units are being altered or added, the number of accessible *Type A* and *Type B* units shall be determined in accordance with Sections [3403.6.7.10.1 through 3403.6.7.10.3](#).

3403.6.7.10.1 Accessible dwelling or sleeping units. Where Group I-1, I-2, I-3, R-1, R-2 or R-4 *dwelling* or *sleeping units* are being altered or added, the requirements of Section 1108 for *accessible units* apply only to the [number of units](#) being altered or added.

Where Group R-2 *dwelling* or *sleeping units* are being added through an *addition*, the requirements of Section 1108 for *accessible units* apply only to the number of units being added.

3403.6.7.10.2 Type A dwelling or sleeping units. Where more than 20 Group R-2 *dwelling* or *sleeping units* are being altered or added, the requirements of Section 1108 for *Type A* units apply only to the [number of units](#) being altered or added.

Exceptions:

1. Where existing bathing facilities are being altered in both Group I-1, Condition 2 residential care facilities without memory care endorsement and Group R-4, Condition 2 residential care facilities without memory care endorsement, one in ten existing bathing facilities shall be required to meet the roll-in type shower compartment requirements of Section 1108 if a common bathing facility is provided outside the *dwelling* or *sleeping unit*.
2. In covered multifamily dwellings, *Type A* units shall apply only to the number of units being added through an *addition*.

3403.6.7.10.3 Type B dwelling or sleeping units. Where four or more Group I-1, I-2, R-1, R-2, R-3 or R-4 *dwelling* or *sleeping units* are being added through an *addition*, the requirements of Section 1108 for *Type B* units apply only to the [number of units](#) being added.

3403.6.7.11 Toilet rooms. Where it is *technically infeasible* to alter existing toilet rooms to be accessible, one accessible single-user toilet room or one accessible family or assisted-use toilet room constructed in accordance with Section 1110.2.1 is permitted. This toilet room shall be located on the same floor and in the same area as the existing toilet rooms. At the inaccessible toilet rooms, directional

signs indicating the location of the nearest such toilet room shall be provided. These directional signs shall include the International Symbol of Accessibility, and sign characters shall meet the visual character requirements in accordance with ICC A117.1.

3403.6.7.12 Bathing rooms. Where it is *technically infeasible* to alter existing bathing rooms to be accessible, one accessible single-user bathing room or one accessible family or assisted-use bathing room constructed in accordance with Section 1110.2.1 is permitted. This accessible bathing room shall be located on the same floor and in the same area as the existing bathing rooms. At the inaccessible bathing rooms, directional signs indicating the location of the nearest such bathing room shall be provided. These directional signs shall include the International Symbol of Accessibility, and sign characters shall meet the visual character requirements in accordance with ICC A117.1.

3403.6.7.13 Additional toilet and bathing facilities. In assembly and mercantile occupancies, where additional toilet fixtures are added, not fewer than one accessible family or assisted-use toilet room shall be provided where required by Section 1110.2.1. In recreational *facilities*, where additional bathing rooms are being added, not fewer than one family or assisted-use bathing room shall be provided where required by Section 1110.2.1.

3403.6.7.14 Dressing, fitting and locker rooms. Where it is *technically infeasible* to provide accessible dressing, fitting or locker rooms at the same location as similar types of rooms, one accessible room on the same level shall be provided. Where separate-sex *facilities* are provided, accessible rooms for each sex shall be provided. Separate-sex *facilities* are not required where only unisex rooms are provided.

3403.6.7.15 Reserved.

3403.6.7.16 Historic structures. Where compliance with the requirements for *accessible routes*, entrances or toilet rooms would threaten or destroy the historic significance of the historic structure, as determined by the *building official after consultation with the appropriate historic preservation officer*, the alternative requirements of Sections [3403.6.7.16.1 through 3403.6.7.16.5](#) for that element shall be permitted.

Exceptions:

- Accessible means of egress* required by Chapter 10 are not required to be provided in historic structures.
- The altered element or space is not required to be on an *accessible route*, unless required by Sections [3403.6.7.16.1 or 3403.6.7.16.2](#).

3403.6.7.16.1 Site arrival points. Not fewer than one exterior *accessible route*, including curb ramps located within an affected building site, from a site arrival point to an accessible entrance, shall be provided and shall not be less than 36 inches (914 mm) minimum in width.

3403.6.7.16.2 Multiple-level buildings and facilities. An *accessible route* from an accessible entrance to public spaces on the level of the accessible entrance shall be provided.

3403.6.7.16.3 Entrances. Where an entrance cannot be made accessible in accordance with Section 3406.7.5, an accessible entrance that is unlocked while the building is occupied shall be provided, or a locked accessible entrance with a notification system or remote monitoring shall be provided.

The route of travel for the accessible entry shall not pass through hazardous areas, storage rooms, closets, kitchens or spaces used for similar purposes.

Signs complying with Section 1112 shall be provided at the public entrances and the accessible entrance.

3403.6.7.16.4 Toilet facilities. Where toilet rooms are provided and alteration of the toilet rooms would adversely affect the historical significance of the building, not fewer than one accessible single-user toilet room or one accessible family or assisted-use toilet room complying with Section 1110.2.1 shall be provided.

3403.6.7.16.5 Bathing facilities. Where bathing rooms are provided and alteration of the bathing rooms would adversely affect the historical significance of the building, not fewer than one accessible single-user bathing room or one accessible family or assisted-use bathing rooms complying with Section 1110.2.1 shall be provided.

3403.6.7.16.6 Type A units. The *alteration* to Type A individually owned *dwelling units* within a Group R-2 occupancy shall be permitted to meet the provision for a Type B *dwelling unit*.

3403.6.7.16.7 Type B units. Type B *dwelling or sleeping units* required by Section 1108 are not required to be provided in *historic buildings*.

3403.7 Smoke alarms and fire alarms.

3403.7.1 Smoke alarms. Where an *alteration, addition, change of occupancy* or relocation of a building is made to an existing building or structure of a Group R or I-1 occupancy, the existing building shall be provided with smoke alarms in accordance with this section.

Exception: Work classified as Level 1 *alterations* in accordance with Section 3407.

3403.7.1.1 Single- and multiple-station smoke alarms. Where required by the selected compliance path, single- and multiple-station *smoke alarms* shall be installed in existing Group I-1 and R occupancies in accordance with Sections 3403.7.1.1.1 through 3403.7.1.1.3.

3403.7.1.1.1 Where required. Existing Group I-1 and R occupancies shall be provided with single-station *smoke alarms* in accordance with Section 907.2.11. Interconnection and power sources shall be in accordance with Sections 3403.7.1.2 and 3403.7.1.3, respectively.

Exceptions:

1. Where the code that was in effect at the time of construction required *smoke alarms* and *smoke alarms* complying with those requirements are already provided.
2. Where *smoke alarms* have been installed in occupancies and dwellings that were not required to have them at the time of construction, additional *smoke alarms* shall not be required provided that the existing *smoke alarms* comply with requirements that were in effect at the time of installation.
3. Where *smoke detectors* connected to a *fire alarm system* have been installed as a substitute for *smoke alarms*.

3403.7.1.1.2 Interconnection. Where more than one *smoke alarm* is required to be installed within an individual *dwelling unit* or *sleeping unit*, the *smoke alarms* shall be interconnected in such a manner that the activation of one alarm will activate all of the alarms in the individual unit. Physical interconnection of *smoke alarms* shall not be required where *listed* wireless alarms are installed and all alarms sound upon activation of one alarm. The alarm shall be clearly audible in all bedrooms over background noise levels with all intervening doors closed.

Exceptions:

1. Interconnection is not required in buildings that are not undergoing *alterations, repairs* or construction of any kind.
2. *Smoke alarms* in existing areas are not required to be interconnected where *alterations or repairs* do not result in the removal of interior wall or ceiling finishes exposing the structure, unless there is an *attic, crawl space or basement* available that could provide access for interconnection without the removal of interior finishes.

3403.7.1.1.3 Power source. *Single-station smoke alarms* shall receive their primary power from the building wiring, provided that such wiring is served from a commercial source and shall be equipped with a battery backup. *Smoke alarms* with integral strobes that are not equipped with battery backup shall be connected to an emergency electrical system. *Smoke alarms* shall emit a signal when the batteries are low. Wiring shall be permanent and without a disconnecting switch other than as required for overcurrent protection.

Exceptions:

1. *Smoke alarms* are permitted to be solely battery operated in existing buildings where construction is not taking place.
2. *Smoke alarms* are permitted to be solely battery operated in buildings that are not served from a commercial power source.
3. *Smoke alarms* are permitted to be solely battery operated in existing areas of buildings undergoing alterations or repairs that do not result in the removal of interior walls or ceiling finishes exposing the structure, unless there is an attic, crawl space or basement available that could provide access for building wiring without the removal of interior finishes.

3403.7.2 Fire alarms.

3403.7.2.1 Fire alarm systems. Where required by the selected compliance path, an approved fire alarm system shall be installed in existing buildings and structures in accordance with Sections 3403.7.2.1.1 through 3403.7.2.1.6 and provide occupant notification in accordance with Section 907.5 unless other requirements are specified by other sections of this chapter.

Exception: Occupancies with an existing, previously approved fire alarm system.

3403.7.2.1.1 Group E. A fire alarm system shall be installed in existing Group E occupancies in accordance with Section 907.2.3.

Exceptions:

1. A manual fire alarm system is not required in a building with a maximum area of 1,000 square feet (93 m²) that contains a single classroom and is located not closer than 50 feet (15,240 mm) from another building.
2. A manual fire alarm system is not required in Group E occupancies with an occupant load less than 50.

3403.7.2.1.2 Group I-1. An automatic fire alarm system shall be installed in existing Group I-1 facilities in accordance with Section 907.2.6.1.

Exception: Where each sleeping room has a means of egress door opening directly to an exterior egress balcony that leads directly to the exits in accordance with Section 1021, and the building is not more than three stories in height.

3403.7.2.1.3 Group I-2. In existing Group I-2 occupancies, an automatic fire alarm system shall be installed in accordance with Section 907.2.6.

Exception: Manual fire alarm boxes in patient sleeping areas shall not be required at exits if located at all nurses' control stations or other constantly attended staff locations, provided that manual fire alarm boxes are visible with ready access, and travel distances required in Section 907.4.2.1 are not exceeded.

3403.7.2.1.4 Group I-3. An automatic and manual fire alarm system shall be installed in existing Group I-3 occupancies in accordance with Section 907.2.6.3.

3403.7.2.1.5 Group R-1. A fire alarm system and smoke alarms shall be installed in existing Group R-1 occupancies in accordance with Sections 3403.7.2.1.5.1 through 3403.7.2.1.6.

3403.7.2.1.5.1 Group R-1 hotel and motel manual fire alarm system. A manual fire alarm system that activates the occupant notification system in accordance with Section 907.5 shall be installed in existing Group R-1 hotels and motels more than one story in height or with more than 20 sleeping units.

Exceptions:

1. A manual fire alarm system is not required in buildings less than two stories in height where all sleeping units, attics and crawl spaces are separated by 1-hour fire-resistance-rated construction and each sleeping unit has direct access to a public way, egress court or yard.
2. A manual fire alarm system is not required in buildings not more than three stories in height with not more than 20 sleeping units and equipped throughout with an automatic sprinkler system installed in accordance with Section 903.3.1.1 or 903.3.1.2.
3. Manual fire alarm boxes are not required throughout the building where the following conditions are met:
 - 3.1. The building is equipped throughout with an automatic sprinkler system installed in accordance with Section 903.3.1.1 or 903.3.1.2.
 - 3.2. The notification appliances will activate upon sprinkler water flow.

3.3. Not less than one *manual fire alarm box* is installed at an *approved* location.

3403.7.2.1.5.1.1 Group R-1 hotel and motel automatic smoke detection system. An *automatic smoke detection system* that activates the occupant notification system in accordance with Section 907.5 shall be installed in existing Group R-1 hotels and motels throughout all interior *corridors* serving sleeping rooms not equipped with an *approved, supervised automatic sprinkler system* installed in accordance with Section 903.

Exception: An *automatic smoke detection system* is not required in buildings that do not have interior *corridors* serving *sleeping units* and where each *sleeping unit* has a *means of egress* door opening directly to an *exit* or to an exterior *exit access* that leads directly to an *exit*.

3403.7.2.1.5.2 Group R-1 boarding and rooming houses manual fire alarm system. A *manual fire alarm system* that activates the occupant notification system in accordance with Section 907.5 shall be installed in existing Group R-1 boarding and rooming houses.

Exception: Buildings less than two *stories* in height where all *sleeping units, attics* and crawl spaces are separated by 1-hour fire-resistance-rated construction and each *sleeping unit* has direct access to a *public way, egress court* or *yard*.

3403.7.2.1.5.2.1 Group R-1 boarding and rooming houses automatic smoke detection system. An *automatic smoke detection system* that activates the occupant notification system in accordance with Section 907.5 shall be installed in existing Group R-1 boarding and rooming houses throughout all interior *corridors* serving *sleeping units* not equipped with an *approved, supervised sprinkler system* installed in accordance with Section 903.

Exception: Buildings equipped with single-station *smoke alarms* meeting or exceeding the requirements of Section 907.2.11.1 and where the *fire alarm system* includes not less than one *manual fire alarm box* per floor arranged to initiate the alarm.

3403.7.2.1.6 Group R-2. A *manual fire alarm system* that activates the occupant notification system in accordance with Section 907.5 shall be installed in existing Group R-2 occupancies more than three *stories* in height or with more than 16 *dwelling* or *sleeping units*.

Exceptions:

1. Where each living unit is separated from other contiguous living units by *fire barriers* having a *fire-resistance rating* of not less than $\frac{3}{4}$ hour, and where each living unit has either its own independent *exit* or its own independent *stairway* or ramp discharging at grade.
2. A separate *fire alarm system* is not required in buildings that are equipped throughout with an *approved supervised automatic sprinkler system* installed in accordance with Section 903.3.1.1 or 903.3.1.2 and having a local alarm to notify all occupants.
3. A *fire alarm system* is not required in buildings that do not have interior *corridors* serving *dwelling units* and are protected by an *approved automatic sprinkler system* installed in accordance with Section 903.3.1.1 or 903.3.1.2 provided that *dwelling units* either have a *means of egress* door opening directly to an exterior *exit access* that leads directly to the *exits* or are served by open-ended *corridors* designed in accordance with Section 1027.6, Exception 3.
4. A *fire alarm system* is not required in buildings that do not have interior *corridors* serving *dwelling units*, do not exceed three *stories* in height and comply with both of the following:
 - 4.1. Each *dwelling unit* is separated from other contiguous *dwelling units* by *fire barriers* having a *fire-resistance rating* of not less than $\frac{3}{4}$ hour.
 - 4.2. Each *dwelling unit* is provided with *hardwired, interconnected smoke alarms* as required for new construction in Section 907.2.11.

3403.8 Carbon monoxide detection.

3403.8.1 Carbon monoxide alarms. Where a *building permit* is required for the reconstruction, alteration or repair of a Group R occupancy, and where an addition, alteration, change of occupancy or relocation of a building is made to Group I-1, I-2, and I-4 occupancies and classrooms of Group E occupancies, *carbon monoxide alarms* shall be installed in accordance with Section 915.

Exceptions:

1. Work involving the *exterior surfaces* of buildings, such as the replacement of roofing or siding, the addition or replacement of windows or doors, or the addition of porches or decks.
2. Work classified as Level 1 *alterations* in accordance with [Section 3407](#).
3. ~~*Carbon monoxide alarms are permitted to be solely battery operated where the code that was in effect at the time of construction did not require carbon monoxide detectors to be provided.*~~
4. ~~*Carbon monoxide alarms are permitted to be solely battery operated in dwelling units that are not served from a commercial power source.*~~
5. ~~*A carbon monoxide detection system in accordance with Section 915.5 shall be an acceptable alternative to carbon monoxide alarms.*~~

3403.9 Group R-2 apartment house substantial alteration or damage. Where *substantial alterations* are made or *substantial damage* occurs to an existing nonsprinklered Group R-2 apartment house, designed and constructed under the provisions of this code, an *approved automatic sprinkler system* complying with [Section 903.3.1.2](#) shall be installed only in the substantially altered or damaged *dwelling units*. Where more than 50 percent of the *dwelling units* within a building are substantially altered or damaged, the entire Group R-2 occupancy shall be provided with an *automatic sprinkler system* complying with [Section 903.3.1.2](#), or equivalent.

For the purposes of this section, where an *automatic sprinkler system* complying with [Section 903.3.1.2](#) is installed, a fire department connection shall not be required.

3403.10 Additions and replacements of exterior wall coverings and exterior wall envelopes.

3403.10.1 General. The provisions of [this section](#) apply to all *alterations, repairs, additions, relocations* of structures and *changes of occupancy* regardless of compliance method.

3403.10.2 Additions and replacements. Where an *exterior wall covering* or *exterior wall envelope* is added or replaced, the materials and methods used shall comply with the requirements for new construction in Chapter 14 and Chapter 26 if the added or replaced *exterior wall covering* or *exterior wall envelope* involves two or more contiguous *stories* and comprises more than 15 percent of the total wall area on any side of the building.

Section 3404 Repairs

3404.1 General.

3404.1.1 Scope. *Repairs* shall comply with the requirements of this [section](#). *Repairs* to *historic buildings* need only comply with [Section 3412](#).

3404.1.1.1 Bleachers, grandstands and folding and telescopic seating. *Repairs* to existing bleachers, grandstands and folding and telescopic seating shall comply with ICC 300.

[ICC 300 Sections 501.2, 502, 503 and 504](#) are not [adopted](#).

3404.1.2 Compliance. The work shall not make the building less compliant than it was before the *repair* was undertaken.

[Devices or safeguards required by this code shall be repaired in accordance with the edition of code under which the device or safeguard was installed. To determine compliance with this subsection, the building official shall have the authority to require a building or structure to be reinspected.](#)

[Work on nondamaged components that is necessary for the required repair of damaged components shall be considered a part of the repair and shall not be subject to the requirements for alterations. Repairs exempt from permit in accordance with Section 105.2 or 3401 are not required to comply with Section 3404.](#)

[Where it becomes necessary to repair all or a portion of a legally existing building that has been damaged by a cause outside of the control of the building owner, including but not limited to fire, wind, flood, earthquake and other similar damage where, prior to the damage, the legally existing building did not contain unsafe conditions, the building may be reconstructed exactly as it existed prior to the damage, where the requirements of this subsection are met. Structural repairs shall comply with the requirements of Section 3404.5. Where unsafe conditions existed prior to the damage occurring, the building may be reconstructed as it existed prior to the damage provided the unsafe conditions are corrected, as determined by the building official. The absence of fire-resistance-rated construction, related building components, automatic sprinkler systems and other life safety features shall not be deemed to be an unsafe condition where such systems and construction methods were not required at the time the building was originally constructed or modified through permit.](#)

3404.1.3 Flood hazard areas. In flood hazard areas [established by the flood plain administrator](#), *repairs* that constitute *substantial improvement* shall require that the building comply with Section 1612.

3404.2 Building elements and materials.

3404.2.1 Glazing in hazardous locations. Replacement glazing in hazardous locations shall comply with the safety glazing requirements [of this code for new construction](#).

Exception: Glass block walls, louvered windows and jalousies repaired with like materials.

3404.3 Fire protection.

3404.3.1 General. *Repairs* shall be done in a manner that maintains the level of *fire protection* provided.

3404.3.2 Substantial damage of Group R-2 apartment houses. [Fire protection shall be provided in Group R-2 apartment houses with substantial damage in accordance with Section 3403.9.](#)

3404.4 Means of egress.

3404.4.1 General. *Repairs* shall be done in a manner that maintains the level of protection provided for the *means of egress*.

3404.5 Structural.

3404.5.1 General. Structural *repairs* shall be in compliance with this section and [Section 3404.1.2](#).

3404.5.2 Repairs to damaged buildings. *Repairs* to damaged buildings shall comply with this section.

3404.5.2.1 Repairs for less than substantial structural damage. Unless otherwise required by this section, for damage less than *substantial structural damage*, the damaged [structural](#) elements shall be permitted to be restored to their predamage condition. [Where either of the following conditions exist, repair of the damaged structural elements shall comply with the requirements of this code for new construction:](#)

- [1. The damage is deemed dangerous.](#)
- [2. The damaged structural elements, in their predamage condition, have a demand-capacity ratio greater than 1.5 for ASD load combinations or 1.3 for LRFD load combinations as determined by Section 1605, using dead loads and live loads determined in accordance with Sections 1606 and 1607.](#)

3404.5.2.1.1 Snow damage. Structural components whose damage was caused by or related to snow load effects shall be repaired, replaced or altered to satisfy the requirements of Section 1608.

3404.5.2.2 Reserved.

3404.5.2.3 Substantial structural damage to vertical elements of the lateral force-resisting system. A building that has sustained *substantial structural damage* to the vertical elements of its lateral force-resisting system shall be evaluated in accordance with [Section 3404.5.2.3.1](#), and either repaired in accordance with [Section 3404.5.2.3.2](#) or repaired and retrofitted in accordance with [Section 3404.5.2.3.3](#), depending on the results of the evaluation.

Exception: Buildings assigned to Seismic Design Category A, B or C whose *substantial structural damage* was not caused by earthquake need not be evaluated or retrofitted for load combinations that include earthquake effects.

3404.5.2.3.1 Evaluation. The building shall be evaluated by a *registered design professional*, and the evaluation findings shall be submitted to the *building official*. The evaluation shall establish whether the damaged building, if repaired to its predamage state, would comply with the *new construction provisions of this code* for load combinations that include wind or earthquake effects, except that the seismic forces shall be the reduced seismic forces.

3404.5.2.3.2 Extent of repair for compliant buildings. If the evaluation establishes that the building in its predamage condition complies with the provisions of Section [3404.5.2.3.1](#), then the damaged elements shall be permitted to be restored to their predamage condition.

3404.5.2.3.3 Extent of repair for noncompliant buildings. If the evaluation does not establish that the building in its predamage condition complies with the provisions of Section [3404.5.2.3.1](#), then the building shall be retrofitted to comply with the provisions of this section. The wind *loads* for the *repair* and *retrofit* shall be those required by the building code in effect at the time of original construction, unless the damage was caused by wind, in which case the wind loads shall be in accordance with [the new construction provisions of this code](#). The seismic *loads* for this *retrofit* design shall be those required by the building code in effect at the time of original construction, but not less than the reduced seismic forces.

3404.5.2.4 Substantial structural damage to gravity load-carrying components. Gravity load-carrying components that have sustained *substantial structural damage* shall be rehabilitated to comply with the applicable [gravity load provisions for new construction in this code](#). Undamaged gravity load-carrying components that receive *gravity loads* from rehabilitated components shall also be rehabilitated if required to comply with the design loads of the *rehabilitation* design.

3404.5.2.4.1 Lateral force-resisting elements. Regardless of the level of damage to vertical elements of the lateral force-resisting system, if *substantial structural damage* to gravity load-carrying components was caused primarily by wind or seismic effects, then the building shall be evaluated in accordance with Section [3404.5.2.3.1](#) and, if noncompliant, retrofitted in accordance with Section [3404.5.2.3.3](#).

Exception: Buildings assigned to Seismic Design Category A, B or C whose *substantial structural damage* was not caused by earthquake need not be evaluated or retrofitted for load combinations that include earthquake effects.

3404.5.2.5 Substantial structural damage to snow load-carrying components. Where *substantial structural damage* to any snow load-carrying components is caused by or related to snow *load* effects, any components required to carry snow *loads* on roof framing of similar construction shall be repaired, replaced or retrofitted to satisfy the requirements of Section 1608.

3404.5.2.6 Flood hazard areas. In *flood hazard areas* [established by the flood plain administrator](#), buildings that have sustained *substantial damage* shall be brought into compliance with Section 1612.

Section 3405 Prescriptive Compliance Method

3405.1 General.

3405.1.1 Scope. The provisions of this [section](#) shall control the *alteration, addition and change of occupancy* of *existing buildings* and structures, including *historic buildings* and structures as referenced in Section [3403.1.3.1](#).

3405.1.1.1 Compliance with other methods. *Alterations, additions and changes of occupancy to existing buildings* and structures shall comply with the provisions of this chapter or with one of the methods provided in Section [3403.1.3](#).

3405.1.2 Fire-resistance ratings. Where *approved* by the [building official](#), in buildings where an *automatic sprinkler system* installed in accordance with Section 903.3.1.1 or 903.3.1.2 has been added, and the building is now sprinklered throughout, the required *fire-resistance ratings* of building elements and materials shall be permitted to meet the requirements of the current building code. The building is required to meet the other applicable requirements [of this code for new construction](#).

Plans, investigation and evaluation reports, and other data shall be submitted indicating which building elements and materials the applicant is requesting the [building official](#) to review and approve for determination of applying the current building code *fire-resistance ratings*. Submitted evaluation reports shall identify any special construction features that impact required *fire-resistance ratings*, including fire-resistance-rated assemblies and smoke-resistive assemblies, conditions of occupancy, *means of egress conditions*, *approved modifications* or *approved alternative materials*, design and methods of construction, and equipment applying to the building.

3405.2 Additions.

3405.2.1 General. *Additions* to any building or structure shall comply with the requirements [of this code](#) for new construction. *Alterations* to the *existing building* or structure shall be made to ensure that the *existing building* or structure together with the *addition* are not less complying with the provisions of [this code for new construction](#) than the *existing building* or structure was prior to the *addition*. An *existing building* together with its *additions* shall comply with the height and area provisions of Chapter 5.

3405.2.2 Reserved.

3405.2.3 Flood hazard areas. For buildings and structures in *flood hazard areas* established [by the flood plain administrator](#), any *addition* that constitutes *substantial improvement* of the *existing structure* shall comply with the flood design requirements [of this code](#) for new construction, and all aspects of the *existing structure* shall be brought into compliance with the requirements [of this code](#) for new construction for flood

design.

For buildings and structures in *flood hazard areas* established [by the flood plain administrator](#) any *additions* that do not constitute *substantial improvement* of the *existing structure* are not required to comply with the flood design requirements [of this code](#) for new construction.

3405.2.4 Existing structural elements carrying gravity load. Any existing gravity load-carrying structural element for which an *addition* and its related *alterations* cause an increase in design [gravity load](#) of more than 5 percent shall be replaced or altered as needed to carry the [design](#) gravity loads required by [this code](#) for new structures. Any existing gravity load-carrying structural element whose vertical load-carrying capacity is decreased as part of the *addition* and its related *alterations* shall be considered to be an altered element subject to the requirements of Section [3405.3.3](#). Any existing element that will form part of the lateral load path for any part of the *addition* shall be considered to be an existing lateral load-carrying structural element subject to the requirements of Section [3405.2.5](#).

3405.2.5 Existing structural elements carrying lateral load. Where the *addition* is structurally independent of the *existing structure*, existing lateral load-carrying structural elements shall be permitted to remain unaltered. Where the *addition* is not structurally independent of the *existing structure*, the *existing structure* and its *addition* acting together as a single structure shall be shown to meet the requirements of Sections 1609 and 1613 using full seismic forces.

Exception: Any existing lateral load-carrying structural element whose demand-capacity ratio with the *addition* considered is not more than 10 percent greater than its demand-capacity ratio with the *addition* ignored shall be permitted to remain unaltered. For purposes of calculating demand-capacity ratios, the demand shall consider applicable load combinations with design lateral loads or forces in accordance with Sections 1609 and 1613.

3405.2.6 Enhanced classroom acoustics. In Group E occupancies, enhanced classroom acoustics shall be provided in all classrooms in the *addition* with a volume of 20,000 cubic feet (565 m³) or less. Enhanced classroom acoustics shall comply with the reverberation time in Section 808 of ICC A117.1.

3405.3 Alterations.

3405.3.1 General. *Alterations* to any building or structure shall comply with the requirements of [this code](#) for new construction. *Alterations* shall be such that the *existing building* or structure is not less complying with the provisions of [this code for new construction](#) than the *existing building* or structure was prior to the *alteration*.

Exceptions:

1. An existing stairway shall not be required to comply with the requirements of Section 1011 where the existing space and construction does not allow a reduction in pitch or slope.
2. Handrails otherwise required to comply with Section 1011.11 shall not be required to comply with the requirements of Section 1014.6 regarding full extension of the handrails where such extensions would [obstruct egress paths](#) because of plan configuration.
3. Where provided in below-grade transportation stations, existing and new escalators shall be permitted to have a clear width of less than 32 inches (815 mm).

3405.3.2 Flood hazard areas. For buildings and structures in *flood hazard areas* established [by the flood plain administrator](#), any *alteration* that constitutes *substantial improvement* of the *existing structure* shall comply with the flood design requirements [of this code](#) for new construction, and all aspects of the *existing structure* shall be brought into compliance with the requirements [of this code](#) for new construction for flood design.

For buildings and structures in *flood hazard areas* established [by the flood plain administrator](#), any *alterations* that do not constitute *substantial improvement* of the *existing structure* are not required to comply with the flood design requirements [of this code](#) for new construction.

3405.3.3 Existing structural elements carrying gravity load. Any existing gravity load-carrying structural element for which an *alteration* causes an increase in design [gravity load](#) of more than 5 percent shall be replaced or altered as needed to carry the [design gravity loads](#) required by [this code](#) for new structures. Any existing gravity load-carrying structural element whose gravity load-carrying capacity is decreased as part of the *alteration* shall be shown to have the capacity to resist the applicable design [gravity loads](#) required by [this code](#) for new structures.

Exception: Buildings in which the increased *dead load* is due entirely to the addition of a second layer of *roof covering* weighing 3 pounds per square foot (0.1437 kN/m²) or less over an existing single layer of *roof covering*.

3405.3.4 Existing structural elements carrying lateral load. Except as permitted by Section [3405.3.13](#), where the *alteration* increases design lateral loads, results in a prohibited structural irregularity as defined in ASCE 7, or decreases the capacity of any existing lateral load-carrying structural element, the structure of the altered building or structure shall meet the requirements of Sections 1609 and 1613. Reduced seismic forces shall be permitted.

Exceptions:

1. Any existing lateral load-carrying structural element whose demand-capacity ratio with the *alteration* considered is not more than 10 percent greater than its demand-capacity ratio with the *alteration* ignored shall be permitted to remain unaltered. For purposes of calculating demand-capacity ratios, the demand shall consider applicable load combinations with design lateral loads or forces in accordance with Sections 1609 and 1613. Reduced seismic forces shall be permitted.
2. *Buildings* in which the increase in the demand-capacity ratio is due entirely to the addition of rooftop-supported mechanical equipment individually having an operating weight less than 400 pounds (181.4 kg) and where the total additional weight of all rooftop equipment placed after initial construction of the *building* is less than 10 percent of the roof *dead load*. For purposes of this exception, “roof” shall mean the roof level above a particular *story*.

[3405.3.5 through 3405.3.12 Reserved.](#)

3405.3.13 Voluntary lateral force-resisting system alterations. Structural *alterations* that are intended exclusively to improve the lateral force-resisting system and are not required by other sections of this [chapter](#) shall not be required to meet the requirements of Section 1609 or 1613, provided that all of the following apply:

1. The capacity of existing structural systems to resist forces is not reduced.
2. New structural elements are detailed and connected to existing or new structural elements as required by [this code](#) for new construction.
3. New or relocated nonstructural elements are detailed and connected to existing or new structural elements as required by [this code](#) for new construction.
4. The *alterations* do not create a structural irregularity as defined in ASCE 7 or make an existing structural irregularity more severe.

3405.3.14 Smoke compartments. In Group I-2 occupancies where the *alteration* is on a *story* used for sleeping rooms for more than 30 care recipients, the *story* shall be divided into not less than two compartments by smoke barrier walls in accordance with Section 407.5 as required for new construction.

[3405.3.15 Reserved.](#)

3405.3.16 Enhanced classroom acoustics. In Group E occupancies, where the *work area* exceeds 50 percent of the *building area*, enhanced classroom acoustics shall be provided in all classrooms with a volume of 20,000 cubic feet (565 m³) or less. Enhanced classroom acoustics shall comply with the reverberation time in Section 808 of ICC A117.1.

3405.3.17 Locking arrangements in educational occupancies. In Group E occupancies, Group B educational occupancies and Group I-4 occupancies, egress doors with locking arrangements designed to keep intruders from entering the room shall comply with Section 1010.2.8.

3405.3.18 Two-way communication systems. Where the *work area* for alterations exceeds 50 percent of the *building area* and the building has elevator service, a two-way communication system shall be provided where required by Section 1009.8.

3405.4 Fire escapes.

3405.4.1 Where permitted. Fire escapes shall be permitted only as provided for in Sections [3405.4.1.1 through 3405.4.1.4](#).

3405.4.1.1 New buildings. Fire escapes shall not constitute any part of the required *means of egress* in new buildings.

3405.4.1.2 Existing fire escapes. Existing fire escapes shall continue to be accepted as a component in the *means of egress* in existing buildings only.

3405.4.1.3 New fire escapes. New fire escapes for existing buildings shall be permitted only where exterior stairways cannot be utilized because of *lot lines* limiting stairway size or because of sidewalks, alleys or roads at grade level. New fire escapes shall not incorporate ladders or access by windows.

3405.4.1.4 Limitations. Fire escapes shall comply with this section and shall not constitute more than 50 percent of the required number of *exits* nor more than 50 percent of the required exit capacity.

3405.4.2 Location. Where located on the front of the building and where projecting beyond the building line, the lowest landing shall be not less than 7 feet (2134 mm) or more than 12 feet (3658 mm) above grade, and shall be equipped with a counterbalanced stairway to the street. In alleyways and thoroughfares less than 30 feet (9144 mm) wide, the clearance under the lowest landing shall be not less than 12 feet (3658 mm).

3405.4.3 Construction. The fire escape shall be designed to support a *live load* of 100 pounds per square foot (4788 Pa) and shall be constructed of steel or other *approved noncombustible materials*. Fire escapes constructed of wood not less than nominal 2 inches (51 mm) thick are permitted on buildings of Type V construction. Walkways and railings located over or supported by combustible roofs in buildings of Type III and IV construction are permitted to be of wood not less than nominal 2 inches (51 mm) thick.

3405.4.4 Dimensions. Stairways shall be not less than 22 inches (559 mm) wide with risers not more than, and treads not less than, 8 inches (203 mm) and landings at the foot of stairways not less than 40 inches (1016 mm) wide by 36 inches (914 mm) long, located not more than 8 inches (203 mm) below the door.

3405.4.5 Opening protectives. Doors and windows within 10 feet (3048 mm) of fire escape stairways shall be protected with $\frac{3}{4}$ -hour opening protectives.

Exception: Opening protection shall not be required in buildings equipped throughout with an *approved automatic sprinkler system*.

3405.5 Windows and emergency escape openings.

3405.5.1 Replacement windows. The installation or replacement of windows shall be as required [by this code](#) for new installations.

3405.5.2 Window opening control devices on replacement windows. In Group R-2 or R-3 buildings containing *dwelling units*, window opening control devices or fall prevention devices complying with ASTM F2090 shall be installed where an existing window is replaced and where all of the following apply to the replacement window:

1. The window is operable.
2. One of the following applies:
 - 2.1. The window replacement includes replacement of the sash and frame.
 - 2.2. The window replacement includes the sash only where the existing frame remains.
3. In Group R-2 or R-3 buildings containing *dwelling units*, the bottom of the clear opening of the window opening is at a height less than 36 inches (915 mm) above the finished floor.
4. The window will permit openings that will allow passage of a 4-inch-diameter (102 mm) sphere when the window is in its largest opened position.
5. The vertical distance from the bottom of the clear opening of the window opening to the finished grade or other surface below, on the exterior of the building, is greater than 72 inches (1829 mm).

Exception: Operable windows where the bottom of the clear opening of the window opening is located more than 75 feet (22 860 mm) above the finished grade or other surface below, on the exterior of the room, space or building, and that are provided with window fall prevention devices that comply with ASTM F2006.

3405.5.3 Replacement window emergency escape and rescue openings. Where windows are required to provide *emergency escape and rescue openings* in Group R-2 and R-3 occupancies replacement windows shall be exempt from the requirements of Section 1031.3, provided that the replacement window is the manufacturer's largest standard size window that will fit within the existing frame or existing rough opening. The replacement window shall be permitted to be of the same operating style as the existing window or a style that provides for an equal or greater window opening area than the existing window.

3405.5.3.1 Control devices. Window opening control devices or fall prevention devices complying with ASTM F2090 shall be permitted for use on windows required to provide *emergency escape and rescue openings*. After operation to release the control device allowing the window to fully open, the control device shall not reduce the net clear opening area of the window unit. *Emergency escape and rescue openings* shall be operational from the inside of the room without the use of keys or tools.

3405.5.4 Bars, grilles, covers or screens. Bars, grilles, covers, screens or similar devices are permitted to be placed over *emergency escape and rescue openings*, bulkhead enclosure or window wells that serve such openings, provided all of the following conditions are met:

1. The minimum net clear opening size complies with the code that was in effect at the time of construction.
2. Such devices shall be releasable or removable from the inside without the use of a key, tool or force greater than that which is required for normal operation of the escape and rescue opening.
3. Where such devices are installed, they shall not reduce the net clear opening of the emergency escape and rescue openings.
4. *Smoke alarms* shall be installed in accordance with [Section 307](#).

3405.6 Change of occupancy.

3405.6.1 Compliance. A *change of occupancy* shall not be made in any building unless that building is made to comply with the [new construction](#) requirements of [this code](#) for the use or occupancy. *Changes of occupancy* in a building or portion thereof shall be such that the *existing building* is not less complying with the provisions of this code than the *existing building* or structure was prior to the change. Subject to the approval of the [building official](#), changes of occupancy shall be permitted without complying with all of the requirements of this code for the new occupancy, provided that the new occupancy is [not more](#) hazardous, based on life and fire risk, than the existing occupancy.

[Unless additions or alterations are made to the building or facility, change of occupancy alone shall not require compliance with the provisions of Chapter 11. Changes in occupancy resulting in multifamily dwellings need not comply with accessible design requirements for covered multifamily dwellings, except where an addition occurs, in accordance with Section 3403.6.](#)

Exception: The building need not be made to comply with Chapter 16 unless required by Section [3405.6.5](#).

3405.6.1.1 Change in the character of use. A change [in character of use](#) with no *change of occupancy* classification shall not be made to any structure that will subject the structure to any special provisions [of this code](#), without approval of the [building official](#). Compliance shall be only as necessary to meet the specific provisions and is not intended to require the entire building be brought into compliance.

3405.6.2 Certificate of occupancy. A certificate of occupancy shall be issued where it has been determined that the requirements for the new occupancy classification have been met.

3405.6.3 Stairways. An existing stairway shall not be required to comply with the requirements of Section 1011 where the existing space and construction does not allow a reduction in pitch or slope.

3405.6.4 Existing emergency escape and rescue openings. Where a *change of occupancy* would require an *emergency escape and rescue opening* in accordance with Section 1031.1, operable windows serving as the *emergency escape and rescue opening* shall comply with the following

1. An existing operable window shall provide a minimum net clear opening of 4 square feet (0.38 m²) with a minimum net clear opening height of 22 inches (559 mm) and a minimum net clear opening width of 20 inches (508 mm).
2. A replacement window where such window complies with both of the following:
 - 2.1. The replacement window meets the size requirements in Item 1.
 - 2.2. The replacement window is the manufacturer's largest standard size window that will fit within the existing frame or existing rough opening. The replacement window shall be permitted to be of the same operating style as the existing window or a style that provides for an equal or greater window opening area than the existing window.

3405.6.5 Structural. Any building undergoing a *change of occupancy* shall satisfy the requirements of this section.

3405.6.5.1 Live loads. Structural elements carrying tributary *live loads* from an area with a *change of occupancy* shall satisfy the requirements of Section 1607. Design *live loads* for areas of new occupancy shall be based on Section 1607. Design *live loads* for other areas shall be permitted to use previously *approved design live loads*.

Exception: Structural elements whose demand-capacity ratio considering the *change of occupancy* is not more than 5 percent greater than the demand-capacity ratio based on previously *approved live loads* need not comply with this section.

3405.6.5.2 Snow and wind loads. Where a *change of occupancy* results in a structure being assigned to a higher *risk category*, the entire structure shall satisfy the requirements of Sections 1608 and 1609 for the new *risk category*.

Exception: Where the area of the new occupancy is less than 10 percent of the *building area*, compliance with this section is not required.

3405.6.5.3 Seismic loads (seismic force-resisting system). Where a *change of occupancy* results in a building being assigned to a higher *risk category*, or where the change is from a Group S or Group U occupancy to any occupancy other than Group S or Group U, the entire structure shall satisfy the requirements of Section 1613 for the new *risk category* using full seismic forces.

Exceptions:

1. Specific seismic detailing requirements of Section 1613 for a new structure shall not be required to be met where the seismic performance is shown to be equivalent to that of a new structure. A demonstration of equivalence shall consider the regularity, overstrength, redundancy and ductility of the structure.
2. Where a *change of use* results in a building being reclassified from *Risk Category I* or *II* to *Risk Category III* and the seismic coefficient, S_{DS} , is less than 0.33, compliance with this section is not required.
3. Where the change is from a Group S or Group U occupancy and there is no change of *risk category*, use of reduced seismic forces shall be permitted.

3405.6.5.4 Reserved.

3405.6.6 Enhanced classroom acoustics. In Group E occupancies, where the *work area* exceeds 50 percent of the *building area*, enhanced classroom acoustics shall be provided in all classrooms with a volume of 20,000 cubic feet (565 m³) or less. Enhanced classroom acoustics shall comply with the reverberation time in Section 808 of ICC A117.1.

3405.7 Historic buildings.

3405.7.1 General. Alterations and additions necessary for the preservation, restoration, rehabilitation or continued use of a building or structure may be made without conformance to all the requirements of this code when authorized by the building official, provided that:

1. The building or structure has been designated by official action of the legally constituted authority of the municipality as having special historical or architectural significance.
2. Any unsafe conditions are corrected.
3. The restored building or structure will be no more hazardous based on life safety, fire safety and sanitation than the existing building.
4. The building official seeks the advice of the State of Oregon historic preservation officer. In case of appeals related to historic buildings, the local appeals board or the appropriate state appeals board shall seek the advice of the State of Oregon historic preservation officer.

3405.7.2 Reserved.

3405.7.3 Flood hazard areas. Within *flood hazard areas* established by the flood plain administrator, where the work proposed constitutes *substantial improvement*, the building shall be brought into compliance with Section 1612.

Exception: *Historic buildings* meeting any of the following criteria need not be brought into compliance:

1. Listed or preliminarily determined to be eligible for listing in the National Register of Historic Places.
2. Determined by the Secretary of the US Department of Interior as contributing to the historical significance of a registered historic district or a district preliminarily determined to qualify as an historic district.
3. Designated as historic under a state or local historic preservation program that is approved by the Department of Interior.

3405.7.4 Structural. *Historic buildings* shall comply with the applicable structural provisions of Section 3405.

Exception: The building official shall be authorized to accept existing floors and existing *live loads* and to approve operational controls that limit the *live load* on any floor.

3405.7.5 Substantial structural damage. Repair of substantial structural damage is not required to comply with Sections 3404.5.2.3, and 3404.5.2.4. *Substantial structural damage* shall be repaired in accordance with Section 3404.5.2.1.

Section 3406 Classification of Work

3406.1 General.

3406.1.1 Scope. The provisions of [Sections 3406.1.1 through 3406.7.2](#) shall be used in conjunction with [Sections 3407, 3408, 3409, 3410, 3411, and 3412](#) and shall apply to the *alteration, addition and change of occupancy* of *existing structures*, including historic and moved structures, as referenced in [Section 3403.3.2](#). The work performed on an *existing building* shall be classified in accordance with this [section](#).

3406.1.1.1 Compliance with other alternatives. *Alterations, additions and changes of occupancy to existing structures* shall comply with the provisions of [Sections 3407, 3408, 3409, 3410, 3411, and 3412](#) or with one of the alternatives provided in [Section 3403.1.3](#).

3406.1.2 Work area. The *work area*, as defined in Chapter 2, shall be identified on the construction documents.

3406.2 Alteration—Level 1.

3406.2.1 Scope. Level 1 *alterations* include the removal and replacement or the covering of existing materials, elements, *equipment* or *fixtures* using new materials, elements, *equipment* or *fixtures* that serve the same purpose.

3406.2.2 Application. Level 1 *alterations* shall comply with the provisions of [Section 3407](#).

3406.3 Alteration—Level 2.

3406.3.1 Scope. Level 2 *alterations* include the addition or elimination of any door or window, the reconfiguration or extension of any system, or the installation of any additional equipment, and shall apply where the *work area* is equal to or less than 50 percent of the *building area*.

3406.3.2 Application. Level 2 *alterations* shall comply with the provisions of [Section 3407](#) for Level 1 *alterations* as well as the provisions of [Section 3408](#).

3406.4 Alteration—Level 3.

3406.4.1 Scope. Level 3 *alterations* apply where the *work area* exceeds 50 percent of the *building area*.

3406.4.2 Application. Level 3 *alterations* shall comply with the provisions of [Sections 3407 and 3408](#) for Level 1 and 2 *alterations*, respectively, as well as the provisions of [Sections 3409](#).

3406.5 Change of occupancy.

3406.5.1 Scope. *Change of occupancy* provisions apply where the activity is classified as a *change of occupancy* as defined in Chapter 2.

3406.5.2 Application. *Changes of occupancy* shall comply with the provisions of [Sections 3410](#).

3406.6 Additions.

3406.6.1 Scope. Provisions for *additions* shall apply where work is classified as an *addition* as defined in Chapter 2.

3406.6.2 Application. *Additions to existing buildings* shall comply with the provisions of [Section 3411](#).

3406.7 Historic buildings.

3406.7.1 Scope. *Historic building* provisions shall apply to *buildings* classified as historic as defined in Chapter 2.

3406.7.2 Application. Except as specifically provided for in [Section 3412](#), *historic buildings* shall comply with applicable provisions of this [chapter](#) for the type of work being performed.

Section 3407 Alterations—Level 1

3407.1 General.

3407.1.1 Scope. Level 1 *alterations* as described in Section [3406.2](#) shall comply with the requirements of this [section](#). Level 1 *alterations to historic buildings* shall comply with this [section](#), except as modified in [Section 3412](#).

3407.1.2 Conformance. An *existing building* or portion thereof shall not be altered such that the building becomes less [compliant with the new construction provisions of this code than the existing building was prior to the alteration](#).

Exception: Where the current level of safety or sanitation is proposed to be reduced, the portion altered shall conform to the requirements [of this code for new construction](#).

3407.1.3 Flood hazard areas. In *flood hazard areas established by the flood plain administrator*, alterations that constitute *substantial improvement* shall require that the building comply with Section 1612.

3407.2 Building elements and materials.

3407.2.1 Interior finishes. Newly installed interior wall and ceiling finishes shall comply with Chapter 8.

3407.2.2 Interior floor finish. New interior floor finish, including new carpeting used as an interior floor finish material, shall comply with Section 804.

3407.2.3 Interior trim. Newly installed interior trim materials shall comply with Section 806.

3407.2.4 Window opening control devices on replacement windows. In Group R-2 or R-3 buildings containing *dwelling units*, window opening control devices complying with ASTM F2090 shall be installed where an existing window is replaced and where all of the following apply to the replacement window:

1. The window is operable.
2. One of the following applies:
 - 2.1. The window replacement includes replacement of the sash and frame.
 - 2.2. The window replacement includes the sash only where the existing frame remains.
3. [The bottom of the clear opening of the window opening is at a height less than 36 inches \(915 mm\) above the finished floor.](#)
4. The window will permit openings that will allow passage of a 4-inch-diameter (102 mm) sphere when the window is in its largest opened position.
5. The vertical distance from the bottom of the clear opening of the window opening to the finished grade or other surface below, on the exterior of the building, is greater than 72 inches (1829 mm).

Exception: Operable windows where the bottom of the clear opening of the window opening is located more than 75 feet (22 860 mm) above the finished grade or other surface below, on the exterior of the room, space or building, and that are provided with window fall prevention devices that comply with ASTM F2006.

3407.2.5 Replacement window for emergency escape and rescue openings. Where windows are required to provide *emergency escape and rescue openings* in Group R-2 and R-3 occupancies replacement windows shall be exempt from the requirements of Section 1031.3 provided that the replacement window is the manufacturer's largest standard size window that will fit within the existing frame or existing rough opening.

3407.2.5.1 Control devices. Window opening control devices or fall prevention devices complying with ASTM F2090 shall be permitted for use on windows required to provide *emergency escape and rescue openings*. After operation to release the control device allowing the window to fully open, the control device shall not reduce the net clear opening area of the window unit. *Emergency escape and rescue openings* shall be operational from the inside of the room without the use of keys or tools.

3407.2.6 Bars, grilles, covers or screens. Bars, grilles, covers, screens or similar devices are permitted to be placed over emergency escape and rescue openings, bulkhead enclosure or window wells that serve such openings, provided all of the following conditions are met:

1. The minimum net clear opening size complies with the code that was in effect at the time of construction.
2. Such devices shall be releasable or removable from the inside without the use of a key, tool or force greater than that which is required for normal operation of the [emergency escape and rescue opening](#).
3. Where such devices are installed, they shall not reduce the net clear opening of the *emergency escape and rescue openings*.
4. *Smoke alarms* shall be installed in accordance with Section 907.2.11.

3407.2.7 Materials and methods. New work shall comply with the materials and methods requirements [of this code for new construction](#), as applicable, that specify material standards, detail of installation and connection, joints, penetrations and continuity of any element, component or system in the building.

3407.3 Reserved.

3407.4 Reserved.

3407.5 Reroofing.

3407.5.1 General. Reroofing shall comply with Section 1512.

3407.6 Structural.

3407.6.1 General. Where *alteration* work includes replacement of equipment that is supported by the building or where a *reroofing permit* is required, the provisions of this section shall apply.

3407.6.2 Addition or replacement of roofing or replacement of equipment. Any existing gravity load-carrying structural element for which an *alteration* causes an increase in design gravity load of more than 5 percent shall be replaced or altered as needed to carry the design gravity loads required by this code for new structures.

Exception: Buildings in which the increased *dead load* is due entirely to the addition of a second layer of *roof covering* weighing 3 pounds per square foot (0.1437 kN/m²) or less over an existing single layer of *roof covering*.

Section 3408 Alterations—Level 2

3408.1 General.

3408.1.1 Scope. Level 2 *alterations* as described in Section 3406.3 shall comply with the requirements of this section.

Exception: Buildings in which the reconfiguration is exclusively the result of compliance with the accessibility requirements of Section 3403.6.7.1 shall be permitted to comply with Section 3407.

3408.1.2 Alteration Level 1 compliance. In addition to the requirements of this section, all work shall comply with the requirements of Section 3407.

3408.1.3 System installations. Requirements related to *work area* are not applicable where the Level 2 *alterations* are limited solely to one or more of the following:

1. Mechanical systems, electrical systems, *fire protection systems* and abatement of *hazardous materials*.
2. Windows, hardware, operating controls, electrical outlets and signs.
3. *Alterations* undertaken for the primary purpose of increasing the accessibility of a *facility*.

3408.1.4 Compliance. New construction elements, components, systems and spaces shall comply with the requirements of this code for new construction.

Exceptions:

1. Where windows are added, they are not required to comply with the light and ventilation requirements of this code for new construction.
2. The length of dead-end *corridors* in newly constructed spaces shall only be required to comply with the provisions of Section 3408.4.7.
3. The minimum ceiling height of the newly created habitable and *occupiable spaces* and *corridors* shall be 7 feet (2134 mm).
4. New structural members and connections shall be permitted to comply with alternative design criteria in accordance with Section 3403.2.

3408.2 Building elements and materials.

3408.2.1 Scope. The requirements of this section are limited to *work areas* in which Level 2 *alterations* are being performed and shall apply beyond the *work area* where specified.

3408.2.2 Vertical openings. Existing vertical openings shall comply with the provisions of Sections 3408.2.2.1, 3408.2.2.2 and 3408.2.2.3.

3408.2.2.1 Existing vertical openings. Existing interior vertical openings connecting two or more floors shall be enclosed with *approved* assemblies

having a *fire-resistance rating* of not less than 1 hour with *approved* opening protectives.

Exceptions:

1. Where vertical opening enclosure is not required by this code for new construction.
2. Interior vertical openings other than stairways may be blocked at the floor and ceiling of the *work area* by installation of not less than 2 inches (51 mm) of solid wood or equivalent construction.
3. The enclosure shall not be required where:
 - 3.1. Connecting the main floor and mezzanines; or
 - 3.2. All of the following conditions are met:
 - 3.2.1. The communicating area has a low-hazard occupancy or has a moderate-hazard occupancy that is protected throughout by an *automatic sprinkler system*.
 - 3.2.2. The lowest or next-to-the-lowest level is a street floor.
 - 3.2.3. The entire area is open and unobstructed in a manner such that it is reasonable to assume that a fire in any part of the interconnected spaces will be readily obvious to all of the occupants.
 - 3.2.4. Exit capacity is sufficient to provide egress simultaneously for all occupants of all levels by considering all areas to be a single floor area for the determination of required exit capacity.
 - 3.2.5. Each floor level, considered separately, has not less than one-half of its individual required exit capacity provided by an *exit* or *exits* leading directly out of that level without having to traverse another communicating floor level or be exposed to the smoke or fire spreading from another communicating floor level.
4. In Group A occupancies, a minimum 30-minute enclosure shall be provided to protect all vertical openings not exceeding three *stories*.
5. In Group B occupancies, a minimum 30-minute enclosure shall be provided to protect all vertical openings not exceeding three *stories*. This enclosure, or the enclosure specified in Section 3408.2.2.1, shall not be required in the following locations:
 - 5.1. Buildings not exceeding 3,000 square feet (279 m²) per floor.
 - 5.2. Buildings protected throughout by an *approved automatic sprinkler system*.

6. In Group E occupancies, the enclosure shall not be required for vertical openings not exceeding three *stories* where the building is protected throughout by an *approved automatic sprinkler system*.
 7. In Group F occupancies, the enclosure shall not be required in the following locations:
 - 7.1. Vertical openings not exceeding three *stories*.
 - 7.2. Special-purpose occupancies where necessary for manufacturing operations and direct access is provided to not fewer than one protected *stairway*.
 - 7.3. Buildings protected throughout by an *approved automatic sprinkler system*.
 8. In Group H occupancies, the enclosure shall not be required for vertical openings not exceeding three *stories* where necessary for manufacturing operations and every floor level has direct access to not fewer than two remote enclosed stairways or other *approved exits*.
 9. In Group M occupancies, a minimum 30-minute enclosure shall be provided to protect all vertical openings not exceeding three *stories*. This enclosure, or the enclosure specified in Section [3408.2.2.1](#), shall not be required in the following locations:
 - 9.1. Openings connecting only two floor levels.
 - 9.2. Occupancies protected throughout by an *approved automatic sprinkler system*.
 10. In Group R-1 occupancies, the enclosure shall not be required for vertical openings not exceeding three *stories* in the following locations:
 - 10.1. Buildings protected throughout by an *approved automatic sprinkler system*.
 - 10.2. Buildings with less than 25 *dwelling units* or *sleeping units* where every sleeping room above the second floor is provided with direct access to a fire escape or other *approved second exit* by means of an *approved exterior door* or window having a sill height of not greater than 44 inches (1118 mm) and where both of the following conditions are met:
 - 10.2.1. Any *exit access* corridor exceeding 8 feet (2438 mm) in length that serves two *means of egress*, one of which is an unprotected vertical opening, shall have not fewer than one of the *means of egress* separated from the vertical opening by a 1-hour *fire barrier*.
 - 10.2.2. The building is protected throughout by an automatic *fire alarm system*, installed and supervised in accordance with the [requirements of this code for new construction](#).
 11. In Group R-2 occupancies, a minimum 30-minute enclosure shall be provided to protect all vertical openings not exceeding three *stories*. This enclosure, or the enclosure specified in Section [3408.2.2.1](#), shall not be required in the following locations:
 - 11.1. Vertical openings not exceeding two *stories* with not more than four *dwelling units* per floor.
 - 11.2. Buildings protected throughout by an *approved automatic sprinkler system*.
 - 11.3. Buildings with not more than four *dwelling units* per floor where every sleeping room above the second floor is provided with direct access to a fire escape or other *approved second exit* by means of an *approved exterior door* or window having a sill height of not greater than 44 inches (1118 mm) and the building is protected throughout by an automatic *fire alarm system* complying with Section [3408.3.4](#).
 12. Group S occupancies where connecting not more than two floor levels or where connecting not more than three floor levels and the structure is equipped throughout with an *approved automatic sprinkler system*.
 13. Group S occupancies where vertical opening protection is not required for open parking garages and ramps.
- [3408.2.2.2](#) Supplemental shaft and floor opening enclosure requirements.** Where the *work area* on any floor exceeds 50 percent of that floor area, the enclosure requirements of Section [3408.2.2](#) shall apply to vertical openings other than stairways throughout the floor.
- Exception:** Vertical openings located in tenant spaces that are entirely outside the *work area*.
- [3408.2.2.3](#) Supplemental stairway enclosure requirements.** Where the *work area* on any floor exceeds 50 percent of that floor area, stairways that are part of the *means of egress* serving the *work area* shall, at a minimum, be enclosed with smoke-tight construction on the highest *work area* floor and all floors below.
- Exception:** Where a stairway enclosure is not required [by this code for new construction](#).

3408.2.3 Smoke compartments. In Group I-2 occupancies where the *work area* is on a *story* used for sleeping rooms for more than 30 care recipients, the *story* shall be divided into not less than two compartments by smoke barrier walls in accordance with Section 407.5 as required for new construction.

3408.2.4 Interior finish. The *interior finish* and trim of walls and ceilings in *exits* and *corridors* in any *work area* shall comply with the requirements [of this code for new construction](#).

Exception: Existing materials that do not comply with the requirements [of this code for new construction](#) shall be permitted to be treated with an approved fire-retardant coating in accordance with the manufacturer's instructions to achieve the required classification. Compliance with this section shall be demonstrated by testing the fire-retardant coating on the same material and achieving the required performance. Where the same material is not available, testing on a similar material shall be permitted.

3408.2.4.1 Supplemental interior finish requirements. Where the *work area* on any floor exceeds 50 percent of the floor area, Section [3408.2.4](#) shall apply to the *interior finish* and trim in *exits* and *corridors* serving the *work area* throughout the floor.

Exception: *Interior finish* within tenant spaces that are entirely outside the *work area*.

3408.2.5 Guards. The requirements of Sections [3408.2.5.1](#) and [2408.2.5.2](#) shall apply in all *work areas*.

3408.2.5.1 Minimum requirement. [Within work areas](#), every portion of a floor, such as a balcony or a loading dock, that is more than 30 inches (762 mm) above the floor or grade below and is not provided with guards, or those in which the existing guards are judged to be in danger of collapsing, shall be provided with guards.

3408.2.5.2 Design. Where there are no guards or where existing guards must be replaced, the guards shall be designed and installed in accordance with the [requirements of this code for new construction](#).

3408.2.6 Fire-resistance ratings. Where *approved* by the [building official](#), buildings where an *automatic sprinkler system* installed in accordance with Section 903.3.1.1 or 903.3.1.2 has been added, and the building is now sprinklered throughout, the required *fire-resistance ratings* of building elements and materials shall be permitted to meet the requirements of [this code](#). The building is required to meet the other applicable requirements [of this code for new construction](#).

Plans, investigation and evaluation reports, and other data shall be submitted indicating which building elements and materials the applicant is requesting the [building official](#) to review and approve for determination of applying the *fire-resistance ratings* [of this code](#). Any special construction features, including

fire-resistance-rated assemblies and smoke-resistive assemblies, conditions of occupancy, means-of-egress conditions, *approved* modifications or *approved* alternative materials, design and methods of construction, and equipment applying to the building that impact required *fire-resistance ratings* shall be identified in the evaluation reports submitted.

3408.3 Fire protection.

3408.3.1 Scope. The requirements of this section shall be limited to *work areas* in which Level 2 *alterations* are being performed, and where specified they shall apply throughout the floor on which the *work areas* are located or otherwise beyond the *work area*.

3408.3.1.1 Corridor ratings. Where an *approved automatic sprinkler system* is installed throughout the *story*, the required *fire-resistance rating* for any corridor located on the *story* shall be permitted to be reduced in accordance with [the requirements of this code for new construction](#). In order to be considered for a corridor rating reduction, such system shall provide coverage for the stairway landings serving the floor and the intermediate landings immediately below.

3408.3.2 Automatic sprinkler systems. *Automatic sprinkler systems* shall be provided in accordance with the requirements of Sections [3408.3.2.1](#) through [3408.3.2.6](#). Installation shall comply with the requirements [of this code for new construction](#).

3408.3.2.1 High-rise buildings. In *high-rise buildings*, *work areas* that have *exits* or *corridors* shared by more than one tenant or that have *exits* or *corridors* serving an *occupant load* greater than 30 shall be provided with *automatic sprinkler protection* in the entire *work area* where the *work area* is located on a floor that has a sufficient sprinkler water supply system from an existing standpipe or a sprinkler riser serving that floor.

3408.3.2.1.1 Supplemental automatic sprinkler system requirements. Where the *work area* on any floor exceeds 50 percent of that floor area, Section [3408.3.2.1](#) shall apply to the entire floor on which the *work area* is located.

Exception: Occupied tenant spaces that are entirely outside the *work area*.

3408.3.2.2 Groups A, B, E, F-1, H, I-1, I-3, I-4, M, R-1, R-2, R-4, S-1 and S-2. In buildings with occupancies in Groups A, B, E, F-1, H, I-1, I-3, I-4, M, R-1, R-2, R-4, S1 and S-2, *work areas* that have *exits* or *corridors* shared by more than one tenant or that have *exits* or *corridors* serving an *occupant load* greater than 30 shall be provided with *automatic sprinkler protection* where both of the following conditions occur:

1. The *work area* is required to be provided with *automatic sprinkler protection* in accordance with the [requirements of this code for new construction](#).

2. The *work area* exceeds 50 percent of the floor area.

Exception: If the building does not have sufficient municipal water supply for design of a fire sprinkler system available to the floor without installation of a new fire pump, *work areas* shall be protected by an *automatic smoke detection system* throughout all *occupiable spaces* other than *sleeping units* or individual *dwelling units* that activates the occupant notification system in accordance with Sections 907.4, 907.5 and 907.6.

3408.3.2.2.1 Mixed uses. In *work areas* containing mixed uses, one or more of which requires *automatic* sprinkler protection in accordance with Section 3408.3.2, such protection shall not be required throughout the *work area* provided that the uses requiring such protection are separated from those not requiring protection by fire-resistance-rated construction having a minimum 2-hour rating for Group H and a minimum 1-hour rating for all other occupancy groups.

3408.3.2.3 Group I-2. In Group I-2 occupancies, an *automatic sprinkler system* installed in accordance with Section 903.3.1.1 shall be provided in the following

1. In Group I-2, Condition 1, throughout the *work area*.
2. In Group I-2, Condition 2, throughout the *work area* where the *work area* is 50 percent or less of the *smoke compartment*.
3. In Group I-2, Condition 2, throughout the *smoke compartment* in which the work occurs where the *work area* exceeds 50 percent of the *smoke compartment*.

3408.3.2.4 Reserved.

3408.3.2.5 Other required automatic sprinkler systems. In buildings and areas listed in Table 903.2.11.6, *work areas* that have *exits* or *corridors* shared by more than one tenant or that have *exits* or *corridors* serving an *occupant load* greater than 30 shall be provided with an *automatic sprinkler system* under the following conditions

1. The *work area* is required to be provided with an *automatic sprinkler system* in accordance with the applicable [requirements of this code for new construction](#); and
2. The building has sufficient municipal water supply for design of an *automatic sprinkler system* available to the floor without installation of a new fire pump.

3408.3.2.6 Supervision. Fire sprinkler systems required by this section shall be supervised by one of the following methods:

1. *Approved* central station system in accordance with NFPA 72.

2. *Approved* proprietary system in accordance with NFPA 72.
3. *Approved* remote station system of the [municipality](#) in accordance with NFPA 72.
4. Where *approved* by the [building official](#), *approved* local alarm service that will cause the sounding of an alarm in accordance with NFPA 72.

Exception: Supervision is not required for the following:

1. Underground key or hub gate valves in roadway boxes.
2. *Halogenated extinguishing systems*.
3. *Carbon dioxide extinguishing systems*.
4. *Dry- and wet-chemical extinguishing systems*.
5. *Automatic sprinkler systems* installed in accordance with NFPA 13R where a common supply main is used to supply both domestic and *automatic sprinkler systems* and a separate shutoff valve for the *automatic sprinkler system* is not provided.

3408.3.3 Standpipes. Where the *work area* includes *exits* or *corridors* shared by more than one tenant and is located more than 50 feet (15 240 mm) above or below the lowest level of [required](#) fire department access, a standpipe system shall be provided. Standpipes shall have an [approved](#) fire department connection with hose connections at each floor level above or below the lowest level of [required](#) fire department access. Standpipe systems shall be installed in accordance with the [requirements of this code for new construction](#).

Exceptions:

1. A pump shall not be required provided that the standpipes are capable of accepting delivery by fire department apparatus of not less than 250 gallons per minute (gpm) at 65 pounds per square inch (psi) (946 L/m at 448 KPa) to the topmost floor in buildings equipped throughout with an *automatic sprinkler system* or not less than 500 gpm at 65 psi (1892 L/m at 448 KPa) to the topmost floor in all other buildings. Where the standpipe terminates below the topmost floor, the standpipe shall be designed to meet (gpm/psi) (L/m/KPa) requirements of this exception for possible future extension of the standpipe.
2. The interconnection of multiple standpipe risers shall not be required.

3408.3.4 Fire alarm and detection. An *approved fire alarm system* shall be installed in accordance with Sections [3408.3.4.1 through 3408.3.4.2](#). Where *automatic* sprinkler protection is provided in accordance with Section [3408.3.2](#) and is connected to the building *fire alarm system*, automatic heat detection shall not be required.

An *approved* automatic fire detection system shall be installed in accordance with the provisions of this code and NFPA 72. Devices, combinations of devices, appliances, and equipment shall be *approved*. The *automatic fire detectors* shall be *smoke detectors*, except that an *approved* alternative type of detector shall be installed in spaces such as boiler rooms, where products of combustion are present during normal operation in sufficient quantity to actuate a *smoke detector*.

3408.3.4.1 Occupancy requirements. A *fire alarm system* shall be installed in accordance with Sections [3408.3.4.1.1 through 3408.3.4.1.6](#). Existing *alarm notification appliances* shall be automatically activated throughout the building. Where the building is not equipped with a *fire alarm system*, *alarm notification appliances* within the *work area* shall be provided and automatically activated.

Exceptions:

1. Occupancies with an existing, previously *approved fire alarm system*.
2. Where selective notification is permitted, *alarm notification appliances* shall be automatically activated in the areas selected.

3408.3.4.1.1 Group E. A *fire alarm system* shall be installed in *work areas* of Group E occupancies [in accordance with Section 3403.7.2](#) for existing Group E occupancies.

3408.3.4.1.2 Group I-1. An automatic *fire alarm system* shall be installed in *work areas* of Group I-1 facilities [in accordance with Section 3403.7.2](#) for existing Group I-1 occupancies.

3408.3.4.1.3 Group I-2. An automatic *fire alarm system* shall be installed throughout Group I-2 occupancies [in accordance with Section 3403.7.2](#).

3408.3.4.1.4 Group I-3. A *fire alarm system* shall be installed in *work areas* of Group I-3 occupancies [in accordance with Section 3403.7.2](#).

3408.3.4.1.5 Group R-1. A *fire alarm system* shall be installed in Group R-1 occupancies [in accordance with Section 3403.7.2](#) for existing Group R-1 occupancies.

3408.3.4.1.6 Group R-2. A *fire alarm system* shall be installed in *work areas* of Group R-2 apartment buildings [in accordance with Section 3403.7.2](#) for existing Group R-2 occupancies.

3408.3.4.2 Supplemental fire alarm system requirements. Where the *work area* on any floor exceeds 50 percent of that floor area, Section [3408.3.4.1](#) shall apply throughout the floor.

Exception: Alarm-initiating and notification appliances shall not be required to be installed in tenant spaces outside of the *work area*.

3408.4 Means of egress.

3408.4.1 Scope. The requirements of this section shall be limited to *work areas* that include *exits* or *corridors* shared by more than one tenant within the *work area* in which Level 2 alterations are being performed, and where specified they shall apply throughout the floor on which the *work areas* are located or otherwise beyond the *work area*.

3408.4.2 General. The *means of egress* shall comply with the requirements of this section.

Exceptions:

1. Where the *work area* and the *means of egress* serving it complies with NFPA 101.
2. *Means of egress* complying with the requirements of the building code under which the building was constructed shall be considered to be compliant *means of egress*.

3408.4.3 Group I-2. In Group I-2 occupancies, in areas where *corridors* are used for movement of care recipients in beds, the clear width of ramps and *corridors* shall be not less than 48 inches (1219 mm).

3408.4.4 Number of exits. The number of *exits* shall be in accordance with Sections [3408.4.4.1 through 3408.4.4.3](#).

3408.4.4.1 Minimum number. Every *story* utilized for human occupancy on which there is a *work area* that includes *exits* or *corridors* shared by more than one tenant within the *work area* shall be provided with the minimum number of *exits* based on the occupancy and the *occupant load* in accordance with the [requirements of this code for new construction](#). In addition, the *exits* shall comply with Sections [3408.4.4.1.1 and 3408.4.4.1.2](#).

3408.4.4.1.1 Single-exit buildings. A single exit or access to a single exit shall be permitted from spaces, any *story* or any occupied roof where one of the following conditions exists:

1. The *occupant load*, number of *dwelling units* and *exit access* travel distance do not exceed the values in [Table 3408.4.4.1.1\(1\) and Table 3408.4.4.1.1\(2\)](#).
2. In Group R-1 or R-2, buildings without an *approved automatic sprinkler system*, individual single-story or multiple-story dwelling or *sleeping units* shall be permitted to have a single exit or access to a single exit from the dwelling or *sleeping unit* provided one of the following criteria are met:
 - 2.1. The *occupant load* is not greater than 10 and the *exit access* travel distance within the unit does not exceed 75 feet (22 860 mm).

- 2.2. The building is not more than three stories in height; all third-story space is part of dwelling with an *exit access* doorway on the second story; and the portion of the *exit access* travel distance from the door to any habitable room within any such unit to the unit entrance doors does not exceed 50 feet (15 240 mm).
3. In buildings of Group R-2 occupancy of any number of stories with not more than four *dwelling units* per floor served by an interior exit stairway; with a smokeproof enclosure in accordance with Sections 909.20 and 1023.12 or an exterior stairway as an *exit*; and where the portion of the *exit access* travel distance from the *dwelling unit* entrance door to the *exit* is not greater than 20 feet (6096 mm).

TABLE 3408.4.4.1.1(1)
STORIES WITH ONE EXIT OR ACCESS TO ONE EXIT FOR R-2 OCCUPANCIES

STORY	OCCUPANCY	MAXIMUM NUMBER OF DWELLING UNITS	MAXIMUM EXIT ACCESS TRAVEL DISTANCE (feet)
Basement, first or second story above grade plane	R-2 ^a	4 dwelling units	50
Third story above grade plane and higher	NP	NA	NA

For SI: 1 foot = 304.8 mm. NP = Not Permitted.
NA = Not Applicable.

a. Group R-2, without an approved *automatic sprinkler system* and provided with emergency escape and rescue openings in accordance with Section 1031.

TABLE 3408.4.4.1.1(2)
STORIES WITH ONE EXIT OR ACCESS TO ONE EXIT FOR OTHER OCCUPANCIES

STORY	OCCUPANCY	MAXIMUM OCCUPANT LOAD PER STORY	MAXIMUM EXIT ACCESS TRAVEL DISTANCE (feet)
First story above or below grade plane	B, F-2, S-2 ^a	35	75
Second story above grade plane	B, F-2, S-2 ^a	35	75
Third story above grade plane and higher	NP	NA	NA

For SI: 1 foot = 304.8 mm. NP = Not Permitted.
NA = Not Applicable.

a. The length of exit access travel distance in a Group S-2 open parking garage shall be not more than 100 feet.

3408.4.4.1.2 Fire escapes required. For other than Group I-2, where more than one *exit* is required, an existing or newly constructed fire escape complying with Section 3408.4.4.1.2.1 shall be accepted as providing one of the required *means of egress*.

3408.4.4.1.2.1 Fire escape access and details. Fire escapes shall comply with all of the following requirements:

1. Occupants shall have unobstructed access to the fire escape without having to pass through a room subject to locking.
2. Access to a new fire escape shall be through a door, except that windows shall be permitted to provide access from single *dwelling units* or *sleeping units* in Group R-1, R-2 and I-1 occupancies or to provide access from spaces having a maximum *occupant load* of 10 in other occupancy classifications.
 - 2.1. The window shall have a minimum net clear opening of 5.7 square feet (0.53 m²) or 5 square feet (0.46 m²) where located at grade.
 - 2.2. The minimum net clear opening height shall be 24 inches (610 mm) and net clear opening width shall be 20 inches (508 mm).
 - 2.3. The bottom of the clear opening shall not be greater than 44 inches (1118 mm) above the floor.
 - 2.4. The operation of the window shall comply with the operational constraints of [this code for new construction](#).
3. Newly constructed fire escapes shall be permitted only where exterior stairways cannot be utilized because of *lot lines* limiting the stairway size or because of the sidewalks, alleys, or roads at grade level.
4. Openings within 10 feet (3048 mm) of fire escape stairways shall be protected by fire assemblies having minimum ³/₄-hour *fire-resistance ratings*.

Exception: Opening protection shall not be required in buildings equipped throughout with an *approved automatic sprinkler system*.
5. In all buildings of Group E occupancy, up to and including the 12th grade, buildings of Group I occupancy, rooming houses and childcare centers, ladders of any type are prohibited on fire escapes used as a required *means of egress*.

3408.4.4.1.2.2 Construction. The fire escape shall be designed to support a *live load* of 100 pounds per square foot (4788 Pa) and shall be constructed of steel or other *approved noncombustible materials*. Fire escapes constructed of wood not less than nominal 2 inches (51 mm) thick are permitted on buildings of Type V construction. Walkways and railings located over or supported by combustible roofs in buildings of Types III and IV construction are permitted to be of wood not less than nominal 2 inches (51 mm) thick.

3408.4.4.1.2.3 Dimensions. Stairways shall be not less than 22 inches (559 mm) wide with risers not more than, and treads not less than, 8 inches (203 mm). Landings at the foot of stairways shall be not less than 40 inches (1016 mm) wide by 36 inches (914 mm) long and located not more than 8 inches (203 mm) below the door.

3408.4.4.2 Mezzanines. Mezzanines undergoing alteration in the *work area* and with an *occupant load* of more than 50 or in which the travel distance to an exit exceeds 75 feet (22 860 mm) shall have access to not fewer than two independent *means of egress*.

Exception: Two independent *means of egress* are not required where the travel distance to an exit does not exceed 100 feet (30 480 mm) and the building is protected throughout with an *automatic sprinkler system*.

3408.4.4.3 Main entrance—Group A. Buildings of Group A with an *occupant load* of 300 or more that are undergoing alteration shall be provided with a main entrance capable of serving as the main exit with an egress capacity of not less than one-half of the total *occupant load*. The remaining *exits* shall be capable of providing one-half of the total required exit capacity.

Exception: Where a main exit is not well defined or where multiple main *exits* are provided, *exits* shall be permitted to be distributed around the perimeter of the building provided that the total width of egress is not less than 100 percent of the required width.

3408.4.5 Egress doorways. Egress doorways in any *work area* shall comply with Sections 3408.4.5.1 through 3408.4.5.5.

3408.4.5.1 Two egress doorways required. Work areas shall be provided with two egress doorways in accordance with the requirements of Sections 3408.4.5.1.1 and 3408.4.5.1.2.

3408.4.5.1.1 Occupant load and travel distance. In any *work area*, all rooms and spaces having an *occupant load* greater than 50 or in which the travel distance to an exit exceeds 75 feet (22 860 mm) shall have not fewer than two egress doorways.

Exceptions:

1. Storage rooms having a maximum *occupant load* of 10.
2. Where the *work area* is served by a single exit in accordance with Section 3408.4.4.1.1.

3408.4.5.1.2 Group I-2. In Group I-2, Condition 2 *work areas* that include altered care suites shall comply with Sections 407.4.4 through 407.4.4.6.2.

3408.4.5.2 Door swing. In the *work area* and in the egress path from any *work area* to the exit discharge, all egress doors serving an *occupant load* greater than 50 shall swing in the direction of exit travel.

3408.4.5.2.1 Supplemental requirements for door swing. Where the *work area* exceeds 50 percent of the floor area, door swing shall comply with Section 3408.4.5.2 throughout the floor.

Exception: *Means of egress* within or serving only a tenant space that is entirely outside the *work area*.

3408.4.5.3 Door closing. In any *work area*, all doors opening onto an exit passageway at grade or an exit stairway shall be self-closing or automatic-closing by listed closing devices.

Exceptions:

1. Where exit enclosure is not required by this code for new construction.
2. *Means of egress* within or serving only a tenant space that is entirely outside the *work area*.

3408.4.5.3.1 Supplemental requirements for door closing. Where the *work area* exceeds 50 percent of the floor area, doors shall comply with Section 804.5.3 throughout the exit stairway from the *work area* to, and including, the level of exit discharge.

3408.4.5.4 Panic and fire exit hardware. In any *work area*, and in the egress path from any *work area* to the exit discharge, in buildings or portions thereof of Group A assembly occupancies with an *occupant load* greater than 100, all required exit doors equipped with latching devices shall be equipped with *approved* panic or fire exit hardware in accordance with Section 1010.2.9.

3408.4.5.4.1 Supplemental requirements for panic hardware. Where the *work area* exceeds 50 percent of the floor area, panic hardware shall comply with Section 3408.4.5.4 throughout the floor.

Exception: *Means of egress* within a tenant space that is entirely outside the *work area*.

3408.4.5.5 Emergency power source in Group I-3. Power-operated sliding doors or power-operated locks for swinging doors shall be operable by a manual release mechanism at the door. Emergency power shall be provided for the doors and locks in accordance with Section 2702.

Exceptions:

1. Emergency power is not required in *facilities* with 10 or fewer locks complying with the exception to Section 408.4.1.
2. Emergency power is not required where remote mechanical operating releases are provided.

3408.4.6 Openings in corridor walls. Openings in corridor walls in any *work area* shall comply with Sections 3408.4.6.1 through 3408.4.6.4.

Exception: Openings in *corridors* where such *corridors* are not required to be rated in accordance with the new construction provisions of this code.

3408.4.6.1 Corridor doors. Corridor doors in the *work area* shall not be constructed of hollow core wood and shall not contain louvers. *Dwelling unit* or *sleeping unit* corridor doors in *work areas* in buildings of Groups R-1, R-2 and I-1 shall be not less than 1³/₈-inch (35 mm) solid core wood or *approved* equivalent and shall not have any glass panels, other than *approved* wired glass or other *approved* glazing material in metal frames. *Dwelling unit* or *sleeping unit* corridor doors in *work areas* in buildings of Groups R-1, R-2 and I-1 shall be equipped with *approved* door closers. Replacement doors shall be 1³/₄-inch (44 mm) solid bonded wood core or *approved* equivalent, unless the existing frame will accommodate only a 1³/₈-inch (35 mm) door.

Exceptions:

1. Corridor doors within a *dwelling unit* or *sleeping unit*.
2. Existing doors meeting the requirements of *Guidelines on Fire Ratings of Archaic Materials and Assemblies* (Resource A) for a rating of 15 minutes or more shall be accepted as meeting the provisions of this requirement.
3. Existing doors in buildings protected throughout with an *approved automatic sprinkler system* shall be required only to resist smoke, be reasonably tight fitting and shall not contain louvers.
4. In group homes with not more than 15 occupants and that are protected with an *approved* automatic detection system, closing devices are not required.
5. Door assemblies having a fire protection rating of not less than 20 minutes.

3408.4.6.2 Transoms. In all buildings of Group I-1, I-2, R-1 and R-2 occupancies, all transoms in corridor walls in *work areas* shall be either glazed with 1/4-inch (6.4 mm) wired glass set in metal frames or other glazing assemblies having a fire protection rating as required for the door and permanently secured in the closed position or sealed with materials consistent with the corridor construction.

3408.4.6.3 Other corridor openings. In any *work area*, unless protected in accordance with Section 716, any other sash, grille or opening in a corridor, and any window in a corridor not opening to the outside air, shall be sealed with materials consistent with the corridor construction.

3408.4.6.3.1 Supplemental requirements for other corridor opening. Where the *work area* exceeds 50 percent of the floor area, Section 3408.4.6.3 shall be applicable to all corridor windows, grills, sashes and other openings on the floor.

Exception: *Means of egress* within or serving only a tenant space that is entirely outside the *work area*.

3408.4.6.4 Supplemental requirements for corridor openings. Where the *work area* on any floor exceeds 50 percent of the floor area, the requirements of Sections 3408.4.6.1 through 3408.4.6.3 shall apply throughout the floor.

3408.4.7 Dead-end corridors. Dead-end *corridors* in any *work area* shall not exceed 35 feet (10 670 mm). In Group I-2 occupancies, dead-end *corridors* shall not exceed 30 feet (9144 mm).

Exceptions:

1. Where dead-end *corridors* of greater length are permitted [by this code for new construction](#).
2. In other than Group A, I-2 and H occupancies, the maximum length of an existing dead-end corridor shall be 50 feet (15 240 mm) in buildings equipped throughout with an automatic *fire alarm system* installed in accordance with [the requirements of this code for new construction](#).
3. In other than Group A, I-2 and H occupancies, the maximum length of an existing dead-end corridor shall be 70 feet (21 356 mm) in buildings equipped throughout with an *automatic sprinkler system* installed in accordance with [the requirements of this code for new construction](#).
4. In other than Group A, I-2 and H occupancies, the maximum length of an existing, newly constructed, or extended dead-end corridor shall not exceed 50 feet (15 240 mm) on floors equipped with an *automatic sprinkler system* installed in accordance with [the requirements of this code for new construction](#).

3408.4.8 Means-of-egress lighting. Means-of-egress lighting shall be in accordance with this section, as applicable.

3408.4.8.1 Artificial lighting required. *Means of egress* in all *work areas* shall be provided with artificial lighting in accordance with the requirements [of this code for new construction](#).

3408.4.8.2 Supplemental requirements for means-of-egress lighting. Where the *work area* on any floor exceeds 50 percent of that floor area, *means of egress* throughout the floor shall comply with Section [3408.4.8.1](#).

Exception: *Means of egress* within or serving only a tenant space that is entirely outside the *work area*.

3408.4.9 Exit signs. Exit signs shall be in accordance with this section, as applicable.

3408.4.9.1 Work areas. *Means of egress* in all *work areas* shall be provided with exit signs in accordance with the requirements [of this code for new construction](#).

3408.4.9.2 Supplemental requirements for exit signs. Where the *work area* on any floor exceeds 50 percent of that floor area, *means of egress* throughout the floor shall comply with Section [3408.4.9.1](#).

Exception: *Means of egress* within a tenant space that is entirely outside the *work area*.

3408.4.10 Handrails. The requirements of Sections [3408.4.10.1](#) and [3408.4.10.2](#) shall apply to handrails from the *work area* floor to, and including, the level of exit discharge.

3408.4.10.1 Minimum requirement. Every required exit stairway that is part of the *means of egress* for any *work area* and that has three or more risers and is not provided with not fewer than one handrail, or in which the existing handrails are judged to be in danger of collapsing, shall be provided with handrails for the full length of the stairway on not fewer than one side. Exit *stairways* with a required egress width of more than 66 inches (1676 mm) shall have handrails on both sides.

3408.4.10.2 Design. Handrails required in accordance with Section [3408.4.10.1](#) shall be designed and installed in accordance with the provisions of [this code for new construction](#).

3408.4.11 Refuge areas. Where *alterations* affect the configuration of an area utilized as a refuge area, the capacity of the refuge area shall not be reduced below the required capacity of the refuge area for horizontal *exits* in accordance with Section 1026.4. Where the horizontal exit also forms a *smoke compartment*, the capacity of the refuge area for Group I-1, I-2 and I-3 occupancies and Group B ambulatory care *facilities* shall not be reduced below that required in Sections 407.5.3, 408.6.2, 420.6.1 and 422.3.2, as applicable.

3408.4.12 Guards. The requirements of Sections [3408.4.12.1](#) and [3408.4.12.2](#) shall apply to guards from the *work area* floor to, and including, the level of exit discharge but shall be confined to the egress path of any *work area*.

3408.4.12.1 Minimum requirement. Every open portion of a stairway, landing, or balcony that is more than 30 inches (762 mm) above the floor or grade below and is not provided with guards, or those portions in which existing guards are judged to be in danger of collapsing, shall be provided with guards.

3408.4.12.2 Design. Guards required in accordance with Section [3408.4.12.1](#) shall be designed and installed in accordance with the [requirements of this code for new construction](#).

3408.5 Structural.

3408.5.1 General. Structural elements and systems within buildings undergoing Level 2 *alterations* shall comply with this section.

3408.5.2 Existing structural elements carrying gravity loads. Any existing gravity load-carrying structural element for which an *alteration* causes an increase in design [gravity load](#) of more than 5 percent shall be replaced or altered as needed to carry the [design gravity loads](#) required by [this code](#) for new structures. Any existing gravity load-carrying structural element whose gravity load-carrying capacity is decreased as part of the *alteration* shall be shown to have the capacity to resist the applicable design [gravity load](#) required by [this code](#) for new structures.

Exceptions:

1. Buildings of Group R occupancy with not more than five *dwelling* or *sleeping units* used solely for residential purposes where the altered building complies with the conventional light-frame construction methods [of this code for new construction](#).
2. Buildings in which the increased *dead load* is attributable to the addition of a second layer of *roof covering* weighing 3 pounds per square foot (0.1437 kN/m²) or less over an existing single layer of *roof covering*.

3408.5.3 Existing structural elements resisting lateral loads. Except as permitted by Section [3408.5.4](#), where the *alteration* increases design lateral *loads*, or where the *alteration* results in prohibited structural irregularity as defined in ASCE 7, or where the *alteration* decreases the capacity of any existing lateral load-carrying structural element, the structure of the altered building or structure shall meet the requirements of Sections 1609 and 1613. Reduced seismic forces shall be permitted.

Exception: Any existing lateral load-carrying structural element whose demand-capacity ratio with the *alteration* considered is not more than 10 percent greater than its demand-capacity ratio with the *alteration* ignored shall be permitted to remain unaltered. For purposes of calculating demand-capacity ratios, the demand shall consider applicable load combinations with design lateral loads or forces in accordance with Sections 1609 and 1613. Reduced seismic forces shall be permitted.

3408.5.4 Voluntary lateral force-resisting system alterations. Structural *alterations* that are intended exclusively to improve the lateral force-resisting system and are not required by other sections of this [chapter](#) shall not be required to meet the requirements of Section 1609 or Section 1613, provided that the following conditions are met:

1. The capacity of existing structural systems to resist forces is not reduced.
2. New structural elements are detailed and connected to existing or new structural elements as required by [this code](#) for new construction.
3. New or relocated nonstructural elements are detailed and connected to existing or new structural elements as required by [this code](#) for new construction.
4. The *alterations* do not create a structural irregularity as defined in ASCE 7 or make an existing structural irregularity more severe.

Section 3409 Alterations—Level 3

3409.1 General.

3409.1.1 Scope. Level 3 *alterations* as described in Section [3406.4](#) shall comply with the requirements of this [section](#).

3409.1.2 Compliance. In addition to the provisions of this [section](#), work shall comply with all of the requirements of [Section 3407 and 3408](#). The requirements of Sections [3408.2, 3408.3, 3408.4 and 3408.5](#) shall apply within all *work areas* whether or not they include *exits* and *corridors* shared by more than one tenant and regardless of the *occupant load*.

Exception: Buildings in which the reconfiguration of space affecting *exits* or shared egress access is exclusively the result of compliance with the accessibility requirements of Section [3403.6.7.1](#) shall not be required to comply with this [section](#).

3409.2 Special use and occupancy.

3409.2.1 High-rise buildings. Any building having occupied floors more than 75 feet (22 860 mm) above the lowest level of [required](#) fire department vehicle access shall comply with the requirements of Sections [3409.2.1.1 and 3409.2.1.2](#).

3409.2.1.1 Recirculating air or exhaust systems. Where a floor is served by a recirculating air or exhaust system with a capacity greater than 15,000 cubic feet per minute (701 m³/s), that system shall be equipped with *approved* smoke and heat detection devices installed in accordance with the *Mechanical Code*.

3409.2.1.2 Elevators. Where there is an elevator or elevators for public use, not fewer than one elevator serving the *work area* shall comply with this section. Existing elevators with a travel distance of 25 feet (7620 mm) or more above or below the main floor or other level of a building and intended to serve the needs of emergency personnel for fire-fighting or rescue purposes shall be provided with emergency operation in accordance with [the Elevator Code](#).

New elevators shall be provided with Phase I emergency recall operation and Phase II emergency in-car operation in accordance with [the Elevator Code](#).

3409.2.2 Boiler and furnace equipment rooms. Boiler and furnace equipment rooms adjacent to or within Group I-1, I2, I-4, R-1, R-2 and R-4 occupancies shall be enclosed by 1-hour fire-resistance-rated construction.

Exceptions:

1. Steam boiler equipment operating at pressures of 15 pounds per square inch gauge (psig) (103.4 kPa) or less is not required to be enclosed.
2. Hot water boilers operating at pressures of 170 psig (1171 kPa) or less are not required to be enclosed.

3. Furnace and boiler equipment with 400,000 British thermal units (Btu) (4.22 × 10⁸ J) per hour input rating or less is not required to be enclosed.
4. Furnace rooms protected with an *automatic sprinkler system* are not required to be enclosed.

3409.3 Building elements and materials.

3409.3.1 Existing shafts and vertical openings.

Existing stairways that are part of the *means of egress* shall be enclosed in accordance with Section [3408.2.2.1](#) from the highest *work area* floor to, and including, the level of exit discharge and all floors below.

3409.3.2 Fire partitions in Group R-3. Fire separation in Group R-3 occupancies shall be in accordance with Section [3409.3.2.1](#).

3409.3.2.1 Separation required. Where the *work area* is in any attached *dwelling unit* in Group R-3 or any multiple single-family dwelling, walls separating the *dwelling units* that are not continuous from the foundation to the underside of the roof sheathing shall be constructed to provide a continuous fire separation using construction materials consistent with the existing wall or complying with the requirements of [this code](#) for new structures. Work shall be performed on the side of the *dwelling unit* wall that is part of the *work area*.

Exception: Where *alterations* do not result in the removal of wall or ceiling finishes exposing the structure, walls are not required to be continuous through concealed floor spaces.

3409.3.3 Interior finish. *Interior finish* in *exits* serving the *work area* shall comply with Section [3408.2.4](#) between the highest floor on which there is a *work area* to the floor of exit discharge.

3409.3.4 Enhanced classroom acoustics. In Group E occupancies, where the *work area* is a Level 3 *alteration*, enhanced classroom acoustics shall be provided in all classrooms with a volume of 20,000 cubic feet (565 m³) or less. Enhanced classroom acoustics shall comply with the reverberation time in Section 808 of ICC A117.1.

3409.4 Fire protection.

3409.4.1 Automatic sprinkler systems. An *automatic sprinkler system* shall be provided in a *work area* where required by Section [3408.3.2](#) or this section.

3409.4.1.1 High-rise buildings. An *automatic sprinkler system* shall be provided in *work areas* where the *high-rise building* has a sufficient municipal water supply for the design and installation of an *automatic sprinkler system* at the site.

3409.4.1.2 Rubbish and linen chutes. Rubbish and linen chutes located in the *work area* shall be provided with *automatic sprinkler system* protection or an *approved* automatic fire-extinguishing system where protection of the rubbish and linen chute would be required under the provisions of [this code](#) for new construction.

3409.4.1.3 Upholstered furniture or mattresses. *Work areas* shall be provided with an *automatic sprinkler system* in accordance with the [new construction provisions of this code](#) where any of the following conditions exist:

1. A Group F-1 occupancy used for the manufacture of upholstered furniture or mattresses exceeds 2,500 square feet (232 m²).
2. A Group M occupancy used for the display and sale of upholstered furniture or mattresses exceeds 5,000 square feet (464 m²).
3. A Group S-1 occupancy used for the storage of upholstered furniture or mattresses exceeds 2,500 square feet (232 m²).

3409.4.1.4 Groups A, B, E, F-1, H, I-1, I-3, I-4, M, R-1, R-2, R-4, S-1 and S-2. In buildings with occupancies in Groups A, B, E, F-1, H, I-1, I-3, I-4, M, R-1, R-2, R-4, S-1 and S-2 *work areas* shall be provided with automatic sprinkler protection where all of the following conditions occur:

1. The *work area* is required to be provided with automatic sprinkler protection in accordance with the [requirements of this code for](#) the new construction.
2. The building site has sufficient municipal water supply for design and installation of an *automatic sprinkler system*.

Exception: If the building site does not have sufficient municipal water supply for design of an *automatic sprinkler system*, *work areas* shall be protected by an *automatic smoke detection system* throughout all *occupiable spaces* other than *sleeping units* or individual *dwelling units* that activates the occupant notification system in accordance with Sections 907.4, 907.5 and 907.6.

3409.4.1.5 Group I-2. In Group I-2 occupancies, an *automatic sprinkler system* installed in accordance with Section [907.2.6](#) shall be provided in the following:

1. In Group I-2, Condition 1, throughout the *work area*.
2. In Group I-2, Condition 2, throughout the *work area* where the *work area* is 50 percent or less of the *smoke compartment*.
3. In Group I-2, Condition 2, throughout the *smoke compartment* in which the work occurs where the *work area* exceeds 50 percent of the *smoke compartment*.

3409.4.1.6 Reserved.

3409.4.1.7 Other required automatic sprinkler systems. In buildings and areas listed in Table 903.2.11.6, *work areas* shall be provided with an *automatic sprinkler system* under the following conditions:

1. The *work area* is required to be provided with an *automatic sprinkler system* in accordance with the [requirements of this code for](#) new construction.
2. The building site has sufficient municipal water supply for design and installation of an *automatic sprinkler system*.

3409.4.2 Fire alarm and detection systems. Fire alarm and detection shall be provided in accordance with Section 907 as required for new construction.

3409.4.2.1 904.2.1 Manual fire alarm systems. Where required by this code [for new construction](#), a manual *fire alarm system* shall be provided throughout the *work area*. Alarm notification appliances shall be provided on such floors and shall be automatically activated as required [by this code for new construction](#).

Exceptions:

1. Alarm-initiating and notification appliances shall not be required to be installed in tenant spaces outside of the *work area*.
2. Visual alarm notification appliances are not required, except where an existing alarm system is upgraded or replaced or where a new *fire alarm system* is installed.

3409.4.2.2 Automatic fire detection. Where required [by this code](#) for new buildings, automatic fire detection systems shall be provided throughout the *work area*.

3409.5 Means of egress.

3409.5.1 General. The *means of egress* shall comply with the requirements of Section [3408.4](#) except as specifically required in Sections [3409.5.2](#) and [3409.5.3](#).

3409.5.2 Means-of-egress lighting. *Means of egress* from the highest *work area* floor to the floor of exit discharge shall be provided with artificial lighting within the exit enclosure in accordance with the requirements of this code [for new construction](#).

3409.5.3 Exit signs. *Means of egress* from the highest *work area* floor to the floor of exit discharge shall be provided with exit signs in accordance with the requirements [of this code for new construction](#).

3409.5.4 Two-way communications systems. In buildings with elevator service, a two-way communication system shall be provided where required by Section 1009.8.

3409.6 Structural.

3409.6.1 General. Where buildings are undergoing Level 3 *alterations*, the provisions of this [Section 3408.5](#) shall apply.

IEBC 906.2 through 906.7 *Not adopted*

3409.7 Energy conservations.

3409.7.1 Minimum requirements. Level 3 *alterations* to *existing buildings* or structures are permitted without requiring the entire building or structure to comply with the energy requirements of the *Energy Code*. The *alterations* shall conform to the energy requirements of the *Energy Code*.

Section 3410 Change of Occupancy

3410.1 General.

3410.1.1 Scope. The provisions of this [section](#) shall apply where a *change of occupancy* occurs, as defined in Section 202.

3410.1.2 Certificate of occupancy. A certificate of occupancy shall be issued where it has been determined that the requirements for the *change of occupancy* have been met.

3410.2 Special use and occupancy.

3410.2.1 Compliance. Where an *existing building* or part of an *existing building* undergoes a *change of occupancy* to one of the special use or occupancy categories as described in Chapter 4, the building shall comply with all of the requirements of Chapter 4 applicable to the special use or occupancy.

3410.2.2 Incidental uses. Where a portion of a building undergoes a *change of occupancy* to one of the incidental uses listed in Table 509.1, the incidental use shall comply with Section 509 applicable to the incidental use.

3410.2.3 Change of occupancy in health care. Where a *change of occupancy* occurs to a Group I-2 or I-1 facility, the *work area* with the *change of occupancy* shall comply with the [new construction requirements of this code](#).

Exception: A change in use or occupancy in the following cases shall not be required to meet the [requirements of this code for new construction](#):

1. Group I-2, Condition 2 to Group I-2, Condition 1.
2. Group I-2 to ambulatory health care.
3. Group I-2 to Group I-1.
4. Group I-1, Condition 2 to Group I-1, Condition 1.

3410.2.4 Storage. In Group I-2 occupancies, equipped throughout with an automatic sprinkler in accordance with Section 903.3.1.1, where a room 250 square feet (23.2 m²) or less undergoes a change in occupancy to a storage room, the room shall be separated from the remainder of the building by construction capable of resisting the passage of smoke in accordance with Section 509.4.2.

3410.3 Building elements and materials.

3410.3.1 General. Building elements and materials in portions of buildings undergoing a *change of occupancy* classification shall comply with Section [3410.11](#).

3410.4 Fire protection.

3410.4.1 General. Fire protection requirements of Section [3410.11](#) shall apply where a building or portions thereof undergo a *change of occupancy* classification or where there is a change of occupancy within a space where there is a different fire protection system threshold requirement in Chapter 9.

3410.5 Means of egress.

3410.5.1 General. *Means of egress* in portions of buildings undergoing a change of occupancy classification shall comply with Section [3410.11](#).

3410.6 Structural.

3410.6.1 Live loads. Structural elements carrying tributary *live loads* from an area with a *change of occupancy* shall satisfy the requirements of Section 1607. Design *live loads* for areas of new occupancy shall be based on Section 1607. Design *live loads* for other areas shall be permitted to use previously *approved design live loads*.

Exception: Structural elements whose demand-capacity ratio considering the *change of occupancy* is not more than 5 percent greater than the demand-capacity ratio based on previously *approved live loads*.

3410.6.2 Snow and wind loads. Where a *change of occupancy* results in a structure being assigned to a higher *risk category*, the structure shall satisfy the requirements of Sections 1608 and 1609 for the new *risk category*.

Exception: Where the area of the new occupancy is less than 10 percent of the *building area*.

3410.6.3 Seismic loads. Where a *change of occupancy* results in a building being assigned to a higher *risk category*, or where the change is from a Group S or Group U occupancy to any occupancy other than Group S or Group U, the building shall satisfy the requirements of Section 1613 for the new *risk category* using full seismic forces.

Exceptions:

1. Where a *change of use* results in a building being reclassified from Risk Category I or II to Risk Category III and the seismic coefficient, S_{DS} , is less than 0.33, compliance with this section is not required.
2. Where the area of the new occupancy is less than 10 percent of the *building area*, the occupancy is not changing from a Group S or Group U occupancy, and the new occupancy is not assigned to Risk Category IV, compliance with this section is not required.
3. Where the change is from a Group S or Group U occupancy and there is no change of *risk category*, use of reduced seismic forces shall be permitted.

3410.6.4 Access to Risk Category IV. Any structure that provides operational access to an adjacent structure assigned to Risk Category IV as the result of a change of occupancy shall itself satisfy the requirements of Sections 1608, 1609 and 1613. For compliance with Section 1613, the full seismic forces shall be used. Where operational access to Risk Category IV is less

than 10 feet (3048 mm) from either an interior *lot line* or from another structure, access protection from potential falling debris shall be provided.

3410.7 through 3410. 9 Reserved.

3410.10 Other requirements.

3410.1.1 Light and ventilation. Light and ventilation shall comply with the requirements of [this code](#) for the new occupancy.

3410.11 Change of occupancy classification.

3410.11.1 General. The provisions of this section shall apply to buildings or portions thereof undergoing a *change of occupancy* classification. This includes a *change of occupancy* classification within a group as well as a *change of occupancy* classification from one group to a different group or where there is a *change of occupancy* within a space where there is a different *fire protection system* threshold requirement in Chapter 9. Such buildings shall also comply with Sections [3410.2 through 3410.10](#).

3410.11.2 Fire protection systems. *Fire protection systems* shall be provided in accordance with Sections [3410.11.2.1 and 3410.11.2.2](#).

3410.11.2.1 Fire sprinkler system. [An automatic sprinkler system shall be provided](#) where a *change in occupancy in a building or* within a space where there is a different fire protection system threshold requirement in Chapter 9 that requires an *automatic fire sprinkler system* to be provided based on the new occupancy in accordance with Chapter 9. The installation of the *automatic sprinkler system* shall be required within the area of the *change of occupancy* and areas of the building not separated horizontally and vertically from the [area of the change of occupancy](#) by one of the following:

1. Nonrated permanent partition and horizontal assemblies.
2. *Fire partition.*
3. *Smoke partition.*
4. *Smoke barrier.*
5. *Fire barrier.*
6. *Fire wall.*

3410.11.2.2 Fire alarm and detection system. Where a *change of occupancy in a building or* within a space where there is a different *fire protection system* threshold requirement in Chapter 9 that requires a fire alarm and detection system to be provided based on the new occupancy in accordance with Chapter 9, such system shall be provided throughout the area where the *change of occupancy* occurs. Existing alarm notification appliances shall be automatically activated throughout the building. Where the building is not equipped with a *fire alarm system*, alarm notification appliances shall [only be required to](#) be provided throughout the area where the

change of occupancy occurs in accordance with Section 907 as required for new construction.

3410.11.3 Interior finish. In areas of the building undergoing the *change of occupancy* classification, the *interior finish* of walls and ceilings shall comply with the requirements of [this code](#) for the new occupancy classification.

3410.11.4 Enhanced classroom acoustics. In Group E occupancies, where the *work area* is a Level 3 *alteration*, enhanced classroom acoustics shall be provided in all classrooms with a volume of 20,000 cubic feet (565 m³) or less. Enhanced classroom acoustics shall comply with the reverberation time in Section 808 of ICC A117.1.

3410.11.5 Means of egress, general. Hazard categories in regard to life safety and *means of egress* shall be in accordance with [Table 3410.11.5](#).

**TABLE 3410.11.5
MEANS OF EGRESS HAZARD CATEGORIES**

RELATIVE HAZARD	OCCUPANCY CLASSIFICATIONS
1 (Highest Hazard)	H
2	I-2; I-3; I-4
3	A; E; I-1; M; R-1; R-2; R-4, Condition 2
4	B; F-1; R-3; R-4, Condition 1; S-1
5 (Lowest Hazard)	F-2; S-2; U

3410.11.5.1 Means of egress for change to a higher-hazard category. Where a change of occupancy classification is made to a higher-hazard category (lower number) as shown in [Table 3410.11.5](#), the *means of egress* shall comply with the requirements of Chapter 10.

Exceptions:

1. Stairways shall be enclosed in compliance with the applicable provisions of Section [3409.3.1](#).
2. Existing stairways including handrails and guards complying with the requirements of [Section 3409](#) shall be permitted for continued use subject to approval of the [building official](#).
3. Any stairway replacing an existing stairway within a space where the pitch or slope cannot be reduced because of existing construction shall not be required to comply with the maximum riser height and minimum tread depth requirements.
4. Existing corridor walls constructed on both sides of wood lath and plaster in good condition or 1/2-inch-thick (12.7 mm) gypsum wallboard shall be permitted. Such walls shall either terminate at the underside of a ceiling of equivalent construction or extend to the underside of the floor or roof next above.

5. Existing *corridor* doorways, transoms and other corridor openings shall comply with the requirements in Sections [3408.4.6.1 through 3408.4.6.4](#).
6. Existing dead-end *corridors* shall comply with the requirements in Section [3408.4.7](#).
7. An operable window complying with Section [3410.11.5.6](#) shall be accepted as an *emergency escape and rescue opening*.

3410.11.5.2 Means of egress for change of use to an equal or lower-hazard category. Where a change of occupancy classification is made to an equal or lesser-hazard category (higher number) as shown in [Table 3410.11.5](#), existing elements of the *means of egress* shall comply with the requirements of Section 905 for the new occupancy classification. Newly constructed or configured *means of egress* shall comply with the requirements of Chapter 10.

Exception: Any stairway replacing an existing stairway within a space where the pitch or slope cannot be reduced because of existing construction shall not be required to comply with the maximum riser height and minimum tread depth requirements.

3410.11.5.3 Egress capacity. Egress capacity shall meet or exceed the *occupant load* as specified in the [new construction provisions of this code](#) for the new occupancy.

3410.11.5.4 Handrails. Existing stairways shall comply with the handrail requirements of Section [3408.4.10](#) in the area of the *change of occupancy* classification.

3410.11.5.5 Guards. Existing guards shall comply with the requirements in Section [3408.4.12](#) in the area of the *change of occupancy* classification.

3410.11.5.6 Existing emergency escape and rescue openings. Where a *change of occupancy* would require an *emergency escape and rescue opening* in accordance with Section 1031, operable windows serving as the *emergency escape and rescue opening* shall comply with the following:

1. An existing operable window shall provide a minimum net clear opening of 4 square feet (0.38 m²) with a minimum net clear opening height of 22 inches (559 mm) and a minimum net clear opening width of 20 inches (508 mm).
2. A replacement window where such window complies with both of the following:
 - 2.1. The replacement window meets the size requirements in Item 1.
 - 2.2. The replacement window is the manufacturer's largest standard size window that will fit within the existing frame or existing rough opening. The replacement window shall be permitted to be of the same operating style as the existing window or a style that provides for

an equal or greater window opening area than the existing window.

3410.11.6 Heights and areas. Hazard categories in regard to height and area shall be in accordance with [Table 3410.11.6](#).

**TABLE 3410.11.6
HEIGHTS AND AREAS HAZARD CATEGORIES**

RELATIVE HAZARD	OCCUPANCY CLASSIFICATIONS
1 (Highest Hazard)	H
2	A-1; A-2; A-3; A-4; I; R-1; R-2; R-4, Condition 2
3	E; F-1; S-1; M
4 (Lowest Hazard)	B; F-2; S-2; A-5; R-3; R-4, Condition 1; U

3410.11.6.1 Height and area for change to a higher-hazard category. Where a change of occupancy classification is made to a higher-hazard category as shown in [Table 3410.11.6](#), heights and areas of buildings and structures shall comply with the requirements of Chapter 5 for the new occupancy classification.

Exception: For *high-rise buildings* constructed in compliance with a previously issued permit, the type of construction reduction specified in Section 403.2.1 is permitted. This shall include the reduction for columns. The *high-rise building* is required to be equipped throughout with an *automatic sprinkler system* in accordance with Section 903.3.1.1.

3410.11.6.1.1 Fire wall alternative. In other than Groups H, F-1 and S-1, *fire barriers* and horizontal assemblies constructed in accordance with Sections 707 and 711, respectively, shall be permitted to be used in lieu of *fire walls* to subdivide the building into separate buildings for the purpose of complying with the area limitations required for the new occupancy where all of the following conditions are met:

1. The buildings are protected throughout with an *automatic sprinkler system* in accordance with Section 903.3.1.1.
2. The maximum allowable area between *fire barriers*, horizontal assemblies or any combination thereof shall not exceed the maximum allowable area determined in accordance with Chapter 5 without an increase allowed for an *automatic sprinkler system* in accordance with Section 506.
3. The *fire-resistance rating* of the *fire barriers* and horizontal assemblies shall be not less than that specified for *fire walls* in Table 706.4.

Exception: Where horizontal assemblies are used to limit the maximum allowable area, the required *fire-resistance rating* of the horizontal assemblies shall be permitted to be reduced by 1 hour provided that the height and number of *stories* increases allowed for an *automatic sprinkler system* by Section 504 are not used for the buildings.

3410.11.6.2 Height and area for change to an equal or lesser-hazard category. Where a change of occupancy classification is made to an equal or lesser-hazard category as shown in Table [3410.11.6](#), the height and area of the *existing building* shall be deemed acceptable.

3410.11.6.3 Fire barriers. Where a *change of occupancy* classification is made to a higher-hazard category as shown in Table [3410.11.6](#), *fire barriers* in separated mixed use buildings shall comply with the fire-resistance requirements [of this code for new construction](#).

Exception: Where the *fire barriers* are required to have a 1-hour *fire-resistance rating*, existing wood lath and plaster in good condition or existing 1/2-inch-thick (12.7 mm) gypsum wallboard shall be permitted.

3410.11.7 Exterior wall fire-resistance ratings. Hazard categories in regard to *fire-resistance ratings* of *exterior walls* shall be in accordance with [Table 3410.11.7](#).

**TABLE 3410.11.7
EXPOSURE OF EXTERIOR WALLS HAZARD CATEGORIES**

RELATIVE HAZARD	OCCUPANCY CLASSIFICATION
1 (Highest Hazard)	H
2	F-1; M; S-1
3	A; B; E; I; R
4 (Lowest Hazard)	F-2; S-2; U

3410.11.7.1 Exterior wall rating for change of occupancy classification to a higher-hazard category. Where a change of occupancy classification is made to a higher hazard category as shown in Table [3410.11.7](#), *exterior walls* shall have *fire resistance* and exterior opening protectives as required by [this code for new construction](#).

Exception: A 2-hour *fire-resistance rating* shall be allowed where the building does not exceed three *stories* in height and is classified as one of the following groups: A-2 and A-3 with an *occupant load* of less than 300, B, F, M or S.

3410.11.7.2 Exterior wall rating for change of occupancy classification to an equal or lesser-hazard category. Where a *change of occupancy* classification is made to an equal or lesser-hazard category as shown in Table [3410.11.7](#), existing *exterior walls*, including openings, shall be accepted.

3410.11.7.3 Opening protectives. Openings in *exterior walls* shall be protected as required by [this code for new construction](#). Where openings in the *exterior walls* are required to be protected because of their distance from the *lot line*, the sum of the area of such openings shall not exceed 50 percent of the total area of the wall in each *story*.

Exceptions:

1. Where the [new construction provisions of this code](#) permit openings in excess of 50 percent.

2. Protected openings shall not be required in buildings of Group R occupancy that do not exceed three *stories* in height and that are located not less than 3 feet (914 mm) from the *lot line*.
3. Exterior opening protectives are not required where an *automatic sprinkler system* has been installed throughout.
4. Exterior opening protectives are not required where the *change of occupancy* group is to an equal or lower hazard classification in accordance with [Table 3410.11.7](#).

3410.11.8 Enclosure of vertical shafts. Enclosure of vertical shafts shall be in accordance with Sections [3410.11.8.1 through 3410.11.8.4](#).

3410.11.8.1 Minimum requirements. Vertical shafts shall be designed to meet the [new construction](#) requirements [of this code](#) for atriums or the requirements of this section.

3410.11.8.2 Stairways. Where a change of occupancy classification is made to a higher-hazard category as shown in [Table 3410.11.5](#), interior stairways shall be enclosed as required [by this code for new construction](#).

Exceptions:

1. In other than Group I occupancies, an enclosure shall not be required for openings serving only one adjacent floor and that are not connected with *corridors* or stairways serving other floors.
2. Unenclosed existing stairways need not be enclosed in a continuous vertical shaft if each *story* is separated from other *stories* by 1-hour fire-resistance-rated construction or *approved* wired glass set in steel frames and all exit *corridors* are sprinklered. The openings between the corridor and the occupant space shall have not fewer than one sprinkler head above the openings on the tenant side. The sprinkler system shall be permitted to be supplied from the domestic water-supply systems, provided that the system is of adequate pressure, capacity and sizing for the combined domestic and sprinkler requirements.
3. Existing penetrations of stairway enclosures shall be accepted if they are protected in accordance with the [new construction provisions of this code](#).

3410.11.8.3 Other vertical shafts. Interior vertical shafts other than stairways, including but not limited to elevator hoistways and service and utility shafts, shall be enclosed as required by [this code for new construction](#) where there is a *change of use* to a higher-hazard category as specified in Table [3410.11.5](#).

Exceptions:

1. Existing 1-hour interior shaft enclosures shall be accepted where a higher rating is required.
2. Vertical openings, other than stairways, in buildings of other than Group I occupancy and connecting less than six *stories* shall not be required to be enclosed if the entire building is provided with an *approved automatic sprinkler system*.

3410.11.8.4 Openings. Openings into existing vertical shaft enclosures shall be protected by fire assemblies having a fire protection rating of not less than 1 hour and shall be maintained self-closing or shall be automatic-closing by actuation of a *smoke detector*. Other openings shall be fire protected in an *approved* manner. Existing fusible link-type automatic door-closing devices shall be permitted in all shafts except stairways if the fusible link rating does not exceed 135°F (57°C).

Section 3411 Additions

3411.1 General.

3411.1.1 Scope. An *addition* to a building or structure shall comply with the [provisions of this code](#) for new construction without requiring the *existing building* or structure to comply with [those](#) requirements or these provisions, except as required by this [section](#). Where an *addition* impacts the *existing building* or structure, that portion shall comply with this [chapter](#).

3411.1.2 Creation or extension of nonconformity. An *addition* shall not create or extend any nonconformity in the *existing building* to which the *addition* is being made with regard to accessibility, structural strength, fire safety, [or means of egress](#).

3411.1.3 Other work. Any *alteration* work within an *existing building* to which an *addition* is being made shall comply with the applicable requirements for the work as classified in [Section 3406](#).

3411.1.4 Enhanced classroom acoustics. In Group E occupancies, enhanced classroom acoustics shall be provided in all classrooms in the *addition* with a volume of 20,000 cubic feet (565 m³) or less. Enhanced classroom acoustics shall comply with the reverberation time in Section 808 of ICC A117.1.

3411.2 Heights and areas.

3411.2.1 Height limitations. An *addition* shall not increase the height of an *existing building* beyond that permitted under the applicable provisions of Chapter 5 for new buildings.

3411.2.2 Area limitations. An *addition* shall not increase the area of an *existing building* beyond that permitted under the applicable provisions of Chapter 5 for new buildings unless fire separation as required [by Chapter 5](#) is provided.

Exception: In-filling of floor openings and nonoccupiable appendages such as elevator and exit stairway shafts shall be permitted beyond that permitted by [this code for new construction](#).

3411.2.3 Fire protection systems. Existing *fire areas* increased by the *addition* shall comply with Chapter 9.

3411.3 Structural.

3411.3.1 Additional gravity loads. Any existing gravity load-carrying structural element for which an *addition* and its related *alterations* cause an increase in design [gravity load](#) of more than 5 percent shall be replaced or altered as needed to carry the [design gravity loads](#) required [by this code](#) for new structures. Any existing gravity load-carrying structural element whose gravity load-carrying capacity is decreased as part of the *addition* and its related *alterations* shall be considered to be an altered element subject to the requirements of Section [3408.5.2](#). Any existing element that will form

part of the lateral load path for any part of the *addition* shall be considered to be an existing lateral load-carrying structural element subject to the requirements of Section [3411.3.2](#).

3411.3.2 Lateral force-resisting system. Where the *addition* is structurally independent of the *existing structure*, existing lateral load-carrying structural elements shall be permitted to remain unaltered. Where the *addition* is not structurally independent of the *existing structure*, the *existing structure* and its *addition* acting together as a single structure shall meet the requirements of Sections 1609 and 1613 using full seismic forces.

Exception: Any existing lateral load-carrying structural element whose demand-capacity ratio with the *addition* considered is not more than 10 percent greater than its demand-capacity ratio with the *addition* ignored shall be permitted to remain unaltered. For purposes of calculating demand-capacity ratios, the demand shall consider applicable load combinations with design lateral loads or forces in accordance with Sections 1609 and 1613.

3411.3.3 Flood hazard areas. *Additions* and *foundations* in *flood hazard areas* [as established by the flood plain administrator](#) shall comply with the following requirements:

1. For horizontal *additions* that are structurally interconnected to the *existing building*:
 - 1.1. If the *addition* and all other proposed work, when combined, constitute *substantial improvement*, the *existing building* and the *addition* shall comply with Section 1612.
 - 1.2. If the *addition* constitutes *substantial improvement*, the *existing building* and the *addition* shall comply with Section 1612.
2. For horizontal *additions* that are not structurally interconnected to the *existing building*:
 - 2.1. The *addition* shall comply with Section 1612.
 - 2.2. If the *addition* and all other proposed work, when combined, constitute *substantial improvement*, the *existing building* and the *addition* shall comply with Section 1612.
3. For vertical *additions* and all other proposed work that, when combined, constitute *substantial improvement*, the *existing building* shall comply with Section 1612.
4. For a raised or extended foundation, if the foundation work and all other proposed work, when combined, constitute *substantial improvement*, the *existing building* shall comply with Section 1612.
5. For a new foundation or replacement foundation, the foundation shall comply with Section 1612.

Section 3412 Historic Buildings

3412.1 General.

3412.1.1 Scope. This section is intended to provide means for the preservation of *historic buildings*. *Historic buildings* shall comply with the provisions of this section relating to their *repair, alteration and change of occupancy*.

3412.1.2 Preservation, restoration, rehabilitation or continued use. Alterations and additions necessary for the preservation, restoration, rehabilitation or continued use of a building or structure may be made without conformance to all the requirements of this code when authorized by the *building official*, provided that:

1. The building or structure has been designated by official action of the legally constituted authority of the *municipality* as having special historical or architectural significance.
2. Any *unsafe* conditions are corrected.
3. The restored building or structure will be no more hazardous based on life safety, fire safety and sanitation than the *existing building*.
4. The *building official* seeks the advice of the State of Oregon historic preservation officer. In case of appeals related to *historic buildings*, the local appeals board or the appropriate state appeals board shall seek the advice of the State of Oregon historic preservation officer.

3412.1.3 Special occupancy exceptions. Where a building in Group R-3 is used for Group A, B or M purposes including exhibits and other public assembly activities, or for museums less than 3,000 square feet (279 m²), the *building official* is authorized to determine that the occupancy is Group B. Adequate *means of egress* in such buildings, including, but not limited to, a means of maintaining doors in an open position to permit egress, a limit on building occupancy to an *occupant load* permitted by the *means of egress* capacity, a limit on occupancy of certain areas or floors, or supervision by a person knowledgeable in the emergency exiting procedures, shall be provided.

3412.1.4 Flood hazard areas. In *flood hazard areas established by the flood plain administrator*, if all proposed work, including *repairs*, work required because of a *change of occupancy*, and *alterations*, constitutes *substantial improvement*, then the *existing building* shall comply with Section 1612.

Exception: If a *historic building* will continue to be a *historic building* after the proposed work is completed, then the proposed work is not considered a *substantial improvement*. For the purposes of this exception, a *historic building* is any of the following:

1. Listed or preliminarily determined to be eligible for listing in the National Register of Historic Places.

2. Determined by the Secretary of the US Department of the Interior to contribute to the historical significance of a registered historic district or a district preliminarily determined to qualify as a historic district.
3. Designated as historic under a state or local historic preservation program that is approved by the Department of the Interior.
4. Designated by official action of the legally constituted authority of the *municipality* as having special historical or architectural significance.

3412.1.5 Reserved.

3412.2 Repairs.

3412.2.1 General. *Repairs* to any portion of a *historic building* or structure shall be permitted with original or like materials and original methods of construction, subject to the provisions of this section. Where it becomes necessary to repair all or a portion of a legally existing *historic building* that has been damaged by a cause outside of the control of the building owner including but not limited to fire, wind, flood, earthquake and other similar damage where, prior to the damage, the legally existing building did not contain *unsafe* conditions, the building may be reconstructed exactly as it existed prior to the damage, where the requirements of this subsection are met. *Hazardous materials*, such as asbestos and lead-based paint, shall not be used where their use in buildings of similar occupancy, purpose and location would not be permitted in the new construction provisions of this code.

3412.2.2 Replacement. Replacement of existing or missing features using original materials shall be permitted. Partial replacement for *repairs* that match the original in configuration, height and size shall be permitted.

Replacement glazing in hazardous locations shall comply with the safety glazing requirements of Chapter 24.

Exception: Glass block walls, louvered windows and jalousies repaired with like materials.

3412.2.3 Substantial structural damage. Repair of substantial structural damage shall be in accordance with Section 3404.5.2.1.

3412.3 Fire safety.

3412.3.1 Scope. *Historic buildings* undergoing *alterations* or *changes of occupancy* shall comply with Section 3412.3.

3412.3.2 General. Every *historic building* that does not conform to the construction requirements specified in this chapter for the occupancy or use and that constitutes a distinct fire hazard as defined herein shall be provided with an *approved* automatic fire-extinguishing system as

determined appropriate by the *building official*. However, an automatic fire-extinguishing system shall not be used to substitute for, or act as an alternative to, the required number of *exits* from any *facility*.

3412.3.3 Means of egress. Existing door openings and corridor and stairway widths less than those specified elsewhere in this *chapter* may be *approved*, provided that, in the opinion of the *building official*, there is sufficient width and height for a person to pass through the opening or traverse the *means of egress*. Where *approved*, the front or main exit doors need not swing in the direction of the path of exit travel, provided that other *approved means of egress* having sufficient capacity to serve the total *occupant load* are provided.

3412.3.4 Transoms. In buildings with *automatic sprinkler systems* of Group R-1, R-2 or R-3, existing transoms in *corridors* and other fire-resistance-rated walls may be maintained if fixed in the closed position. A sprinkler shall be installed on each side of the transom.

3412.3.5 Interior finishes. The existing *interior finishes* shall be accepted where it is demonstrated that they are the historic finishes.

3412.3.6 Stairway enclosure. In buildings of three *stories* or less, exit enclosure construction shall limit the spread of smoke by the use of tight-fitting doors and solid elements. Such elements are not required to have a *fire-resistance rating*.

3412.3.7 One-hour fire-resistant assemblies. Where 1-hour fire-resistance-rated construction is required by these provisions, it need not be provided, regardless of construction or occupancy, where the existing wall and ceiling finish is wood or metal lath and plaster.

3412.3.8 Glazing in fire-resistance-rated systems. Historic glazing materials are permitted in interior walls required to have a 1-hour *fire-resistance rating* where the opening is provided with *approved* smoke seals and the area affected is provided with an *automatic sprinkler system*.

3412.3.9 Stairway railings. Grand stairways shall be accepted without complying with the handrail and guard requirements. Existing handrails and guards at all stairways shall be permitted to remain, provided they are not structurally *dangerous*.

3412.3.10 Guards. Guards shall comply with Sections [3412.3.10.1](#) and [3412.3.10.2](#).

3412.3.10.1 Height. Existing guards shall comply with the requirements of Section [3404.4](#).

3412.3.10.2 Guard openings. The spacing between existing intermediate railings or openings in existing ornamental patterns shall be accepted. Missing elements or members of a *guard* may be replaced in a manner that will preserve the historic appearance of the building or structure.

3412.3.11 Exit signs. Where exit sign or egress path marking location would damage the historic character of the building, alternative exit signs are permitted with approval of the *building official*. Alternative signs shall identify the *exits* and egress path.

3412.3.12 Automatic fire-extinguishing systems. Every *historic building* that cannot be made to conform to the *new construction requirements of this code* for the occupancy or use and that constitutes a distinct fire hazard shall be deemed to be in compliance if provided with an *approved automatic fire-extinguishing system*.

Exception: Where the *building official* approves an alternative *life-safety system*.

3412.4 Change of occupancy.

3412.4.1 General. *Historic buildings* undergoing a *change of occupancy* shall comply with the applicable provisions of [Section 3410](#), except as specifically permitted in this *section*. Where [Section 3410](#) requires compliance with specific requirements of [Section 3407](#), [3408](#), [3409](#) and where those requirements are subject to the exceptions in [Section 3412.2](#), the same exceptions shall apply to this *section*.

3412.4.2 Building area. The allowable floor area for *historic buildings* undergoing a *change of occupancy* shall be permitted to exceed by 20 percent the allowable areas specified in Chapter 5.

3412.4.3 Location on property. Historic structures undergoing a *change of use* to a higher-hazard category in accordance with [Section 3410.11.7](#) may use alternative methods to comply with the fire-resistance and exterior opening protective requirements. Such alternatives shall comply with [Section 3412.1.2](#).

3412.4.4 Occupancy separation. Required occupancy separations of 1 hour may be omitted where the building is provided with an *approved automatic sprinkler system* throughout.

3412.4.5 Roof covering. Regardless of occupancy or use group, roof-covering materials not less than Class C, where tested in accordance with ASTM E108 or UL 790, shall be permitted where a fire-retardant *roof covering* is required.

3412.4.6 Means of egress. Existing door openings and corridor and stairway widths less than those that would be acceptable for nonhistoric buildings under these provisions shall be *approved*, provided that, in the opinion of the *building official*, there is sufficient width and height for a person to pass through the opening or traverse the exit and that the capacity of the exit system is adequate for the *occupant load*, or where other operational controls to limit occupancy are *approved*.

3412.4.7 Door swing. Where *approved* by the *building official*, existing front doors need not swing in the direction of exit travel, provided that other *approved exits* having sufficient capacity to serve the total *occupant load* are provided.

3412.4.8 Transoms. In corridor walls required by these provisions to be fire-resistance rated, existing transoms may be maintained if fixed in the closed position, and fixed wired glass set in a steel frame or other *approved* glazing shall be installed on one side of the transom.

Exception: Transoms conforming to Section [3412.3.4](#) shall be accepted.

3412.4.9 Interior finishes. Where *interior finish* materials are required to comply with the fire test requirements of Section 803.1, existing nonconforming materials shall be permitted to be surfaced with an *approved* fire-retardant coating to achieve the required classification. Compliance with this section shall be demonstrated by testing the fire-retardant coating on the same material and achieving the required fire classification. Where the same material is not available, it shall be permitted to test on a similar material.

Exception: Existing nonconforming materials need not be surfaced with an *approved* fire-retardant coating where the building is equipped throughout with an *automatic sprinkler system* installed in accordance with [Chapter 9](#) and the nonconforming materials can be substantiated as being historic in character.

3412.4.10 One-hour fire-resistant assemblies. Where 1-hour fire-resistance-rated construction is required by these provisions, it need not be provided, regardless of construction or occupancy, where the existing wall and ceiling finish is wood lath and plaster.

3412.4.11 Stairways and guards. Existing stairways shall comply with the requirements of these provisions. The *building official* shall grant alternatives for stairways and guards if alternative stairways are found to be acceptable or are judged to meet the intent of these provisions. Existing stairways shall comply with Section [3412.3](#).

Exception: For buildings less than 3,000 square feet (279 m²), existing conditions are permitted to remain at all stairways and guards.

3412.4.12 Exit signs. The *building official* may accept alternative exit sign locations where the location of such signs would damage the historic character of the building or structure. Such signs shall identify the *exits* and exit path.

3412.4.13 Exit stair live load. Existing historic stairways in buildings changed to a Group R-1 or R-2 occupancy shall be accepted where it can be shown that the stairway can support a 75-pounds-per-square-foot (366 kg/m²) *live load*.

3412.4.14 Natural light. Where it is determined by the *building official* that compliance with the natural light requirements of Section [3410.10.1](#) will lead to loss of historic character or historic materials in the building, the existing level of natural lighting shall be considered to be acceptable.

3412.5 Structural.

3412.5.1 General. *Historic buildings* shall comply with the applicable structural provisions for the work as classified in [Sections 3406](#).

Exception: The *building official* shall be authorized to accept existing floors and existing *live loads* and to approve operational controls that limit the *live load* on any floor.

3412.5.2 Substantial structural damage. *Repair of substantial structural damage* is not required to comply with Sections [3404.5.2.3](#) and [3404.5.2.4](#). *Substantial structural damage* shall be repaired in accordance with Section [3404.5.2.1](#).

3412.6 Relocated buildings.

3412.6.1 Relocated buildings. Relocated *historic buildings* shall [comply with Section 3414](#).

Section 3413 Performance Compliance Methods

3413.1 General.

3413.1.1 Scope. The provisions of this [section](#) shall apply to the *alteration, addition and change of occupancy* of *existing structures*, including historic structures, as referenced in Section [3403.1.3.3](#). [The provisions of this section are intended to maintain or increase the current degree of public safety, health and general welfare in existing buildings while permitting alteration, addition and change of occupancy without requiring full compliance with Section 3405 or Sections 3406 through 3412, except where compliance with other provisions of this chapter is specifically required by this section. The provisions of this section are not mandatory and are intended for optional use by a building owner for elected alterations, additions, and changes of occupancy. Where the provisions of this section are used, the entirety of this section shall apply.](#)

3413.1.1.1 Compliance with other methods. *Alterations, additions and changes of occupancy to existing structures* shall comply with the provisions of this [section](#) or with one of the methods provided in Section [3403.1.3](#).

3413.1.2 Applicability. *Existing buildings* in which there is work involving *additions, alterations or changes of occupancy* shall be made to conform to the requirements of this [section](#) or the provisions of [Section 3406 through 3412](#). The provisions of Sections [3413.1.2.1](#) through [3413.1.2.6](#) shall apply to existing occupancies that will continue to be, or are proposed to be, in Groups A, B, E, F, I-2, M, R and S. These provisions shall also apply to Group U occupancies where such occupancies are undergoing a *change of occupancy* or a partial change in occupancy with separations in accordance with Section [3413.1.2.2](#). These provisions shall not apply to buildings with occupancies in Group H, I-1, I-3 or I-4 [or Group R-3 occupancies constructed in accordance with the Residential Code](#).

3413.1.2.1 Change in occupancy. Where an *existing building* is changed to a new occupancy classification and this section is applicable, the provisions of this section for the new occupancy shall be used to determine compliance with this [chapter](#).

3413.1.2.2 Partial change in occupancy. Where a portion of the building is changed to a new occupancy classification and that portion is separated from the remainder of the building with *fire barrier* or horizontal assemblies having a *fire-resistance rating* as required by Table 508.4 for the separate occupancies, or with *approved* compliance alternatives, the portion changed shall be made to conform to the provisions of this section. Only the portion separated shall be required to be evaluated for compliance.

Where a portion of the building is changed to a new occupancy classification and that portion is not separated from the remainder of the building with *fire barriers* or horizontal assemblies having a *fire-resistance rating* as required by Table 508.4 for the separate occupancies, or with *approved* compliance alternatives, the provisions of this section [that](#) apply to each occupancy shall apply to the entire building. Where there are conflicting provisions, those requirements [that](#) secure the greater public safety shall apply to the entire building or structure.

3413.1.2.3 Additions. *Additions to existing buildings* shall comply with the requirements of [this code](#) for new construction. The combined height and area of the *existing building* and the new *addition* shall not exceed the height and area allowed by Chapter 5. Where a *fire wall* that complies with Section 706 is provided between the *addition* and the *existing building*, the *addition* shall be considered a separate building.

3413.1.2.4 Alterations. An *existing building* or portion thereof shall not be altered in such a manner that results in the building being less [compliant with the new construction provisions of this code than the existing building was prior to the alteration](#).

Exception: Where the current level of safety is proposed to be reduced, the portion altered shall conform to the requirements [of this code for new construction](#).

3413.1.2.5 Escalators. Where escalators are provided in below-grade transportation stations, existing and new escalators shall be permitted to have a clear width of less than 32 inches (815 mm).

3413.1.2.6 Plumbing fixtures. Plumbing fixtures for [alterations, additions and changes of occupancy](#) shall be in accordance with [Chapter 29](#).

3413.1.3 Acceptance. For *repairs, alterations, additions and changes of occupancy to existing buildings* that are evaluated in accordance with this section, compliance with this section shall be accepted by the [building official](#).

3413.1.3.1 Compliance with flood hazard provisions. In *flood hazard areas established by the flood plain administrator*, buildings that are evaluated in accordance with this section shall comply with Section 1612 if the work covered by this section constitutes *substantial improvement*.

3413.1.4 Investigation and evaluation. For proposed work covered by this [section](#), the building owner shall cause the *existing building* to be investigated and evaluated in accordance with the provisions of Sections [3413.1.4.1 through 3413.1.9](#).

3413.1.4.1 Structural analysis. The owner shall have a structural analysis of the *existing building* made to determine the adequacy of structural systems for the proposed *alteration, addition or change of occupancy*. The analysis shall demonstrate that the building with the work completed is capable of resisting the loads specified in Chapter 16.

3413.1.4.2 Submittal. The results of the investigation and evaluation as required in Section 3413.1.4, along with proposed compliance alternatives, shall be submitted to the *building official*.

3413.1.4.3 Determination of compliance. The *building official* shall determine whether the *existing building*, with the proposed *addition, alteration or change of occupancy*, complies with the provisions of this section in accordance with the evaluation process in Sections 3413.1.5 through 3413.1.9.

3413.1.5 Evaluation. The evaluation shall be composed of three categories: fire safety, *means of egress* and general safety, as defined in Sections 3413.1.5.1 through 3413.1.5.3.

3413.1.5.1 Fire safety. Included within the fire safety category are the structural *fire resistance*, automatic fire detection, fire alarm, *automatic sprinkler system* and fire suppression system features of the *facility*.

3413.1.5.2 Means of egress. Included within the *means of egress* category are the configuration, characteristics and support features for *means of egress* in the *facility*.

3413.1.5.3 General safety. Included within the general safety category are the fire safety parameters and the *means of egress* parameters.

3413.1.6 Evaluation process. The evaluation process specified herein shall be followed in its entirety to evaluate *existing buildings* in Groups A, B, E, F, M, R, S and U. For *existing buildings* in Group I-2, the evaluation process specified herein shall be followed and applied to each and every individual *smoke compartment*. Table 3413.1.7 shall be utilized for tabulating the results of the evaluation. References to other sections of this code or other codes indicate that compliance with those sections is required in order to gain credit in the evaluation herein outlined. In applying this section to a building with mixed occupancies, where the separation between the mixed occupancies does not qualify for any category indicated in Section 3413.1.6.16, the score for each occupancy shall be determined, and the lower score determined for each section of the evaluation process shall apply to the entire building or to each *smoke compartment* for Group I-2 occupancies.

Where the separation between the mixed occupancies qualifies for any category indicated in Section 3413.1.6.16, the score for each occupancy shall apply to each portion or *smoke compartment* of the building based on the occupancy of the space.

3413.1.6.1 Building height and number of stories. The value for building height and number of *stories* shall be the lesser value determined by the formula in Section 3413.1.6.1.1. Section 504 shall be used to determine the allowable height and number of *stories* of the building. Subtract the actual building height from the allowable height and divide by 12^{1/2} feet (3810 mm). Enter the height value and its sign (positive or negative) in Table 3413.1.7 under Safety Parameter 3413.1.6.1, Building Height, for fire safety, *means of egress* and general safety. The maximum score for a building shall be 10.

3413.1.6.1.1 Height formula. The following formulas shall be used in computing the building height value.

$$\text{Height value, feet} = \frac{(AH) - (EBH)}{12.5} \times CF \quad (\text{Equation 34-1})$$

$$\text{Height value, stories} = (AS - EBS) \times CF \quad (\text{Equation 34-2})$$

where:

AH = Allowable height in feet (mm) from Section 504.

EBH = Existing building height in feet (mm).

AS = Allowable height in *stories* from Section 504.

EBS = Existing building height in stories.

CF = 1 if $(AH) - (EBH)$ is positive.

CF = Construction-type factor shown in Table 3413.1.6.6(2) if $(AH) - (EBH)$ is negative.

Note: Where mixed occupancies are separated and individually evaluated as indicated in Section 3413.1.6, the values *AH*, *AS*, *EBH* and *EBS* shall be based on the height of the occupancy being evaluated.

3413.1.6.2 Building area. The value for *building area* shall be determined by the formula in Section 3413.1.6.2.2. Section 506 and the formula in Section 3413.1.6.1 shall be used to determine the allowable area of the building. Enter the area value and its sign (positive or negative) in Table 3413.1.7 under Safety Parameter 3413.1.6.2, Building Area, for fire safety, *means of egress* and general safety. In determining the area value, the maximum permitted positive value for area is 50 percent of the fire safety score as listed in Table 3413.1.8, Mandatory Safety Scores. Group I-2 occupancies shall be scored zero.

3413.1.6.2.1 Allowable area formula. The following formula shall be used in computing allowable area:

$$A_a = A_r + (NS \times I_f) \quad (\text{Equation 34-3})$$

where:

A_a = Allowable *building area* per *story* (square feet).

A_t = Tabular allowable area factor (NS, S1, S13R, or SM value, as applicable) in accordance with Table 506.2.

NS = Tabular allowable area factor in accordance with Table 506.2 for a nonsprinklered building (regardless of whether the building is sprinklered).

I_f = Area factor increase due to frontage as calculated in accordance with Section 506.3.

3413.1.6.2.2 Area formula. The following formulas shall be used in computing the area value. Equation 34-4 shall be used for a single occupancy buildings and Equation 34-5 shall be used for multiple occupancy buildings. Determine the area value for each occupancy floor area on a floor-by-floor basis. For multiple occupancy, buildings with the minimum area value of the set of values obtained for the particular occupancy shall be used as the area value for that occupancy.

For single occupancy buildings:

Area value_{*i*} = (Allowable area – Actual area)/1200 square feet

(Equation 34-4)

For multiple occupancy buildings:

$$\text{Area value}_i = \frac{\text{Allowable area}_i}{1200 \text{ square feet}} \left[1 - \left(\frac{\text{Actual area}_i}{\text{Allowable area}_i} + \dots + \frac{\text{Actual area}_n}{\text{Allowable area}_n} \right) \right]$$

(Equation 34-5)

where:

i = Value for an individual separated occupancy on a floor.

n = Number of separated occupancies on a floor.

3413.1.6.3 Compartmentation. Evaluate the compartments created by *fire barriers* or horizontal assemblies which comply with Sections 3413.1.6.3.2 and 3413.1.6.3.3 and which are exclusive of the wall elements considered under Sections 3413.1.6.4 and 3413.1.6.5. Conforming compartments shall be figured as the net area and do not include shafts, chases, stairways, walls or columns. Using Table 3413.1.6.3, determine the appropriate compartmentation value (CV) and enter that value into Table 3413.1.7 under Safety Parameter 3413.1.6.3, Compartmentation, for fire safety, *means of egress* and general safety.

**TABLE 3413.1.6.3
COMPARTMENTATION VALUES**

OCCUPANCY	CATEGORIES ^a				
	a	b	c	d	e
A-1, A-3	0	6	10	14	18
A-2	0	4	10	14	18
A-4, B, E, S-2	0	5	10	15	20
F, M, R, S-1	0	4	10	16	22
I-2	0	2	8	10	14

a. For compartment sizes between categories, the compartmentation value shall be obtained by linear interpolation.

3413.1.6.3.1 Categories. The categories for compartment separations are:

1. Category a—Compartment size of 15,000 square feet (1394 m²) or more.
2. Category b—Maximum compartment size of 10,000 square feet (929 m²).
3. Category c—Maximum compartment size of 7,500 square feet (697 m²).
4. Category d—Maximum compartment size of 5,000 square feet (464 m²).
5. Category e—Maximum compartment size of 2,500 square feet (232 m²).

3413.1.6.3.2 Wall construction. A wall used to create separate compartments shall be a *fire barrier* conforming to Section 707 with a *fire-resistance rating* of not less than 2 hours. Where the building is not divided into more than one compartment, the compartment size shall be taken as the total floor area on all floors. Where there is more than one compartment within a *story*, each compartmented area on such *story* shall be provided with a horizontal exit conforming to Section 1026. The *fire door* serving as the horizontal exit between compartments shall be so installed, fitted and gasketed that such *fire door* will provide a substantial barrier to the passage of smoke.

3413.1.6.3.3 Floor/ceiling construction. A floor/ceiling assembly used to create compartments shall conform to Section 711 and shall have a *fire-resistance rating* of not less than 2 hours.

3413.1.6.4 Tenant and dwelling unit separations. Evaluate the *fire-resistance rating* of floors and walls separating tenants, including *dwelling units*, and not evaluated under Sections 3413.1.6.3 and 3413.1.6.5. Group I-2 occupancies shall evaluate the rating of the separations between care recipient sleeping rooms.

Under the categories and occupancies in Table 3413.1.6.4, determine the appropriate value and enter that value in Table 3413.1.7 under Safety Parameter 3413.1.6.4, Tenant and Dwelling Unit Separation, for fire safety, *means of egress* and general safety. The value shall be zero for single tenant buildings and buildings without *dwelling units*.

**TABLE 3413.1.6.4
SEPARATION VALUES**

OCCUPANCY	CATEGORIES				
	a	b	c	d	e
A-1	0	0	0	0	1
A-2	-5	-3	0	1	3
R	-4	-2	0	2	4
A-3, A-4, B, E, F, M, S-1	-4	-3	0	2	4
I-2	0	1	2	3	4
S-2	-5	-2	0	2	4

3413.1.6.4.1 Categories. The categories for tenant and dwelling unit separations are:

1. Category a—No fire partitions; incomplete fire partitions; no doors; doors not self-closing or automatic-closing.
2. Category b—Fire partitions or floor assemblies with less than 1-hour fire-resistance ratings or not constructed in accordance with Section 708 or 711, respectively.
3. Category c—Fire partitions with 1-hour or greater fire-resistance ratings constructed in accordance with Section 708 and floor assemblies with 1-hour but less than 2-hour fire-resistance ratings constructed in accordance with Section 711 or with only one tenant within the floor area.
4. Category d—Fire barriers with 1-hour but less than 2-hour fire-resistance ratings constructed in accordance with Section 707 and floor assemblies with 2-hour or greater fire-resistance ratings constructed in accordance with Section 711.
5. Category e—Fire barriers and floor assemblies with 2-hour or greater fire-resistance ratings and constructed in accordance with Sections 707 and 711, respectively.

3413.1.6.5 Corridor walls. Evaluate the fire-resistance rating and degree of completeness of walls which create corridors serving the floor and that are constructed in accordance with Section 1020. This evaluation shall not include the wall elements considered under Sections 3413.1.6.3 and 3413.1.6.4. Under the categories and groups in Table 3413.1.6.5, determine the appropriate value and enter that value into Table 3413.1.7 under Safety Parameter 3413.1.6.5, Corridor Walls, for fire safety, means of egress and general safety.

**TABLE 3413.1.6.5
CORRIDOR WALL VALUES**

OCCUPANCY	CATEGORIES			
	a	b	c ^a	d ^a
A-1	-10	-4	0	2
A-2	-30	-12	0	2
A-3, F, M, R, S-1	-7	-3	0	2
A-4, B, E, S-2	-5	-2	0	5
I-2	-10	0	1	2

- a. Corridors not providing at least one-half the exit access travel distance for all occupants on a floor shall use Category b.

3413.1.6.5.1 Categories. The categories for corridor walls are:

1. Category a—No fire partitions; incomplete fire partitions; no doors; or doors not self-closing.
2. Category b—Less than 1-hour fire-resistance rating or not constructed in accordance with Section 708.4.
3. Category c—1-hour to less than 2-hour fire-resistance rating, with doors conforming to Section 716 or corridors as permitted by Section 1020 to be without a fire-resistance rating.
4. Category d—2-hour or greater fire-resistance rating, with doors conforming to Section 716.

3413.1.6.6 Vertical openings. Evaluate the fire-resistance rating of interior exit stairways or ramps, hoistways, escalator openings and other shaft enclosures within the building, and openings between two or more floors. Table 3413.1.6.6(1) contains the appropriate protection values. Multiply that value by the construction-type factor found in Table 3413.1.6.6(2). Enter the vertical opening value and its sign (positive or negative) in Table 3413.1.7 under Safety Parameter 3413.1.6.6, Vertical Openings, for fire safety, means of egress and general safety. If the structure is a one-story building or if all the unenclosed vertical openings within the building conform to the requirements of Section 712, enter a value of 2. The maximum positive value for this requirement (VO) shall be 2.

**TABLE 3413.1.6.6(1)
VERTICAL OPENING PROTECTION VALUE**

PROTECTION	VALUE
None (unprotected opening)	-2 times number of floors connected
Less than 1 hour	-1 times number of floors connected
1 to less than 2 hours	1
2 hours or more	2

**TABLE 3413.1.6.6(2)
CONSTRUCTION-TYPE FACTOR**

FACTOR	TYPE OF CONSTRUCTION								
	I-A	I-B	II-A	II-B	III-A	III-B	IV	V-A	V-B
	1.2	1.5	2.2	3.5	2.5	3.5	2.3	3.3	7

3413.1.6.6.1 Vertical opening formula. The following formula shall be used in computing vertical opening value.

$$VO = PV \times CF \quad \text{(Equation 34-6)}$$

where:

VO = Vertical opening value. The calculated value shall not be greater than positive 2.0.

PV = Protection value from Table 3413.1.6.6(1).

CF = Construction-type factor from Table 3413.1.6.6(2).

3413.1.6.7 HVAC systems. Evaluate the ability of the HVAC system to resist the movement of smoke and fire beyond the point of origin. Under the categories in Section 3413.1.6.7.1, determine the appropriate value and enter that value into Table 3413.1.7 under Safety Parameter 3413.1.6.7, HVAC Systems, for fire safety, means of egress and general safety. Facilities in Group I-2 occupancies meeting Category a, b or c shall be considered to fail the evaluation.

3413.1.6.7.1 Categories. The categories for HVAC systems are:

1. Category a—Plenums not in accordance with Section 602 of the *Mechanical Code*. -10 points.
2. Category b—Air movement in egress elements not in accordance with Section 1020.6 of this code. -5 points.
3. Category c—Both Categories a and b are applicable. -15 points.
4. Category d—Compliance of the HVAC system with Section 1020.6 and Section 602 of the *Mechanical Code*. 0 points.
5. Category e—Systems serving one story; or a central boiler/chiller system without ductwork connecting two or more stories or where systems have no ductwork. +5 points.

3413.1.6.8 Automatic fire detection. Evaluate the smoke detection capability based on the location and operation of automatic fire detectors in accordance with the *Mechanical Code* and Section 907. Under the categories and occupancies in Table 3413.1.6.8, determine the appropriate value and enter that value into Table 3413.1.7 under Safety Parameter 3413.1.6.8, Automatic Fire Detection, for fire safety, means of egress and general safety. Facilities in Group I-2 occupancies meeting Category a, b or c shall be considered to fail the evaluation.

**TABLE 3413.1.6.8
AUTOMATIC FIRE DETECTION VALUES**

OCCUPANCY	CATEGORIES					
	a	b	c	d	e	f
A-1, A-3, F, M, R, S-1	-10	-5	0	2	6	NA
A-2	-25	-5	0	5	9	NA
A-4, B, E, S-2	-4	-2	0	4	8	NA
I-2	NP	NP	NP	4	5	2

NA = Not Applicable. NP = Not Permitted.

3413.1.6.8.1 Categories. The categories for automatic fire detection are:

1. Category a—None.
2. Category b—Existing smoke detectors in HVAC systems.
3. Category c—Smoke detectors in HVAC systems. The detectors are installed in accordance with the requirements for new buildings in the *Mechanical Code*.
4. Category d—Smoke detectors throughout all floor areas other than individual sleeping units, tenant spaces and dwelling units.
5. Category e—Smoke detectors installed throughout the floor area.
6. Category f—Smoke detectors in corridors only.

3413.1.6.9 Fire alarm systems. Evaluate the capability of the fire alarm system in accordance with Section 907. Under the categories and occupancies in Table 3413.1.6.9, determine the appropriate value and enter that value into Table 3413.1.7 under Safety Parameter 3413.1.6.9, Fire Alarm System, for fire safety, means of egress and general safety.

**TABLE 3413.1.6.9
FIRE ALARM SYSTEM VALUES**

OCCUPANCY	CATEGORIES			
	a	b ^a	c	d
A-1, A-2, A-3, A-4, B, E, R	-10	-5	0	5
F, M, S	0	5	10	15
I-2	-4	1	2	5

a. For buildings equipped throughout with an automatic sprinkler system, add 2 points for activation by a sprinkler water-flow device.

3413.1.6.9.1 Categories. The categories for fire alarm systems are:

1. Category a—None.
2. Category b—Fire alarm system with manual fire alarm boxes in accordance with Section 907.4 and alarm notification appliances in accordance with Section 907.5.2.
3. Category c—Fire alarm system in accordance with Section 907.
4. Category d—Category c plus a required emergency voice/alarm communications system and a fire command station that conforms to Section 911 and contains the emergency voice/alarm communications system controls, fire department communication system controls, and any other controls specified in Section 911 where those systems are provided.

3413.1.6.10 Smoke control. Evaluate the ability of a natural or mechanical venting, exhaust or pressurization system to control the movement of smoke from a fire. Under the categories and occupancies in Table 3413.1.6.10, determine the appropriate value and enter that value into Table 3413.1.7 under Safety Parameter 3413.1.6.10, Smoke Control, for *means of egress* and general safety.

**TABLE 3413.1.6.10
SMOKE CONTROL VALUES**

OCCUPANCY	CATEGORIES					
	a	b	c	d	e	f
A-1, A-2, A-3	0	1	2	3	6	6
A-4, E	0	0	0	1	3	5
B, M, R	0	2a	3a	3a	3a	4a
F, S	0	2a	2a	3a	3a	3a
I-2	-4	0	0	0	3	0

a. This value shall be 0 if compliance with Category d or e in Section 3413.1.6.8.1 has not been obtained.

3413.1.6.10.1 Categories. The categories for smoke control are:

1. Category a—None.
2. Category b—The building is equipped throughout with an *automatic sprinkler system*. Openings are provided in exterior walls at the rate of 20 square feet (1.86 m²) per 50 linear feet (15 240 mm) of *exterior wall* in each *story* and distributed around the building perimeter at intervals not exceeding 50 feet (15 240 mm). Such openings shall be readily openable from the inside without a key or separate tool and shall be provided with *ready access* thereto. In lieu of operable openings, clearly and permanently marked tempered glass panels shall be used.
3. Category c—One enclosed exit stairway, with *ready access* thereto, from each occupied floor of the building. The stairway has operable exterior windows, and the building has openings in accordance with Category b.
4. Category d—One smokeproof enclosure and the building has openings in accordance with Category b.
5. Category e—The building is equipped throughout with an *automatic sprinkler system*. Each floor area is provided with a mechanical air handling system designed to accomplish smoke containment. Return and exhaust air shall be moved directly to the outside without recirculation to other floor areas of the building under fire conditions. The system shall exhaust not less than six air changes per hour from the floor area. Supply air by mechanical means to the floor area is not required. Containment of smoke shall be considered as confining smoke to the floor

area involved without migration to other floor areas. Any other tested and *approved* design that will adequately accomplish smoke containment is permitted.

6. Category f—Each stairway shall be one of the following: a smokeproof enclosure in accordance with Section 1023.12; pressurized in accordance with Section 909.20.5; or shall have operable exterior windows.

3413.1.6.11 Means of egress capacity and number.

Evaluate the *means of egress* capacity and the number of *exits* available to the building occupants. In applying this section, the *means of egress* are required to conform to the following Sections: 1003.7, 1004, 1005, 1006, 1007, 1016.2, 1026.1, 1028.3, 1028.5, 1030.2, 1030.3, 1030.4 and 1031. The number of *exits* credited is the number that is available to each occupant of the area being evaluated. Existing fire escapes shall be accepted as a component in the *means of egress* when conforming to Section 3405.4.

Under the categories and occupancies in Table 3413.1.6.11, determine the appropriate value and enter that value into Table 3413.1.7 under Safety Parameters 3413.1.6.11, Means of Egress Capacity, for *means of egress* and general safety.

**TABLE 3413.1.6.11
MEANS OF EGRESS VALUES**

OCCUPANCY	CATEGORIES				
	a ^a	b	c	d	e
A-1, A-2, A-3, A-4, E, I-2	-10	0	2	8	10
M	-3	0	1	2	4
B, F, S	-1	0	0	0	0
R	-3	0	0	0	0

a. The values indicated are for buildings six stories or less in height. For buildings over six stories above grade plane, add an additional -10 points.

3413.1.6.11.1 Categories. The categories for means-of-egress capacity and number of *exits* are:

1. Category a—Compliance with the minimum required *means of egress* capacity or number of *exits* is achieved through the use of a fire escape in accordance with Section 3405.4.
2. Category b—Capacity of the *means of egress* complies with Section 1005, and the number of *exits* complies with the minimum number required by Section 1006.
3. Category c—Capacity of the *means of egress* is equal to or exceeds 125 percent of the required means-of-egress capacity, the *means of egress* complies with the minimum required width dimensions specified in Section 1005, and the number of *exits* complies with the minimum number required by Section 1006.

4. Category d—The number of *exits* provided exceeds the number of *exits* required by Section 1006. *Exits* shall be located a distance apart from each other equal to not less than that specified in Section 1007.
5. Category e—The area being evaluated meets both Categories c and d.

3413.1.6.12 Dead ends. In spaces required to be served by more than one *means of egress*, evaluate the length of the *exit access* travel path in which the building occupants are confined to a single path of travel. Under the categories and occupancies in Table 3413.1.6.12, determine the appropriate value and enter that value into Table 3413.1.7 under Safety Parameters 3413.1.6.12, Dead Ends, for *means of egress* and general safety.

**TABLE 3413.1.6.12
DEAD-END VALUES**

OCCUPANCY	CATEGORIES ^a			
	a	b	c	d
A-1, A-3, A-4, B, F, M, R, S	-2	0	2	-4
A-2, E	-2	0	2	-4
I-2	-2	0	2	-6

a. For dead-end distances between categories, the dead-end value shall be obtained by linear interpolation.

3413.1.6.12.1 Categories. The categories for dead ends are:

1. Category a—Dead end of 35 feet (10 670 mm) in nonsprinklered buildings or 70 feet (21 340 mm) in sprinklered buildings.
2. Category b—Dead end of 20 feet (6096 mm); or 50 feet (15 240 mm) in Group B in accordance with Section 1020.5, Exception 2.
3. Category c—No dead ends; or ratio of length to width (l/w) is less than 2.5:1.
4. Category d—Dead ends exceeding Category a.

3413.1.6.13 Maximum exit access travel distance to an exit. Evaluate the length of *exit access* travel to an *approved* exit. Determine the appropriate points in accordance with the following equation and enter that value into Table 3413.1.7 under Safety Parameters 3413.1.6.13, Maximum Exit Access Travel Distance for *means of egress* and general safety. The maximum allowable *exit access* travel distance shall be determined in accordance with Section 1017.1.

$$\text{Points} = 20 \times \frac{\text{Maximum allowable travel distance} - \text{Maximum actual travel distance}}{\text{Maximum allowable travel distance}}$$

(Equation 34-7)

3413.1.6.14 Elevator control. Evaluate the passenger elevator equipment and controls that are available to the fire department to reach all occupied floors. Emergency recall and in-car operation of elevators shall be provided in accordance with the *Elevator Code*. Under the categories and occupancies in Table 3413.1.6.14, determine the appropriate value and enter that value into Table 3413.1.7 under Safety Parameters 3413.1.6.14, Elevator Control, for fire safety, *means of egress* and general safety. The values shall be zero for a single-story building.

**TABLE 3413.1.6.14
ELEVATOR CONTROL VALUES**

ELEVATOR TRAVEL	CATEGORIES			
	a	b	c	d
Less than 25 feet of travel above or below the primary level of elevator access for emergency fire-fighting or rescue personnel	-2	0	0	+2
Travel of 25 feet or more above or below the primary level of elevator access for emergency fire-fighting or rescue personnel	-4	NP	0	+4

For SI: 1 foot = 304.8 mm. NP = Not Permitted.

3413.1.6.14.1 Categories. The categories for elevator controls are:

1. Category a—No elevator.
2. Category b—Any elevator without Phase I emergency recall operation and Phase II emergency in-car operation.
3. Category c—All elevators with Phase I emergency recall operation and Phase II emergency in-car operation as required by the *Elevator Code*.
4. Category d—All meet Category c; or Category b where permitted to be without Phase I emergency recall operation and Phase II emergency in-car operation; and at least one elevator that complies with new construction requirements serves all occupied floors.

3413.1.6.15 Means of egress emergency lighting. Evaluate the presence of and reliability of *means of egress* emergency lighting. Under the categories and occupancies in Table 3413.1.6.15, determine the appropriate value and enter that value into Table 3413.1.7 under Safety Parameters 3413.1.6.15, Means of Egress Emergency Lighting, for *means of egress* and general safety.

**TABLE 3413.1.6.15
MEANS OF EGRESS EMERGENCY LIGHTING VALUES**

NUMBER OF EXITS REQUIRED BY SECTION 1006	CATEGORIES		
	a	b	c
Two or more exits	NP	0	4
Minimum of one exit	0	1	1

NP = Not Permitted.

3413.1.6.15.1 Categories. The categories for *means of egress* emergency lighting are:

1. Category a—*Means of egress* lighting and exit signs not provided with emergency power in accordance with Section 2702.
2. Category b—*Means of egress* lighting and exit signs provided with emergency power in accordance with Section 2702.
3. Category c—Emergency power provided to *means of egress* lighting and exit signs, which provides protection in the event of power failure to the site or building.

3413.1.6.16 Mixed occupancies. Where a building has two or more occupancies that are not in the same occupancy classification, the separation between the mixed occupancies shall be evaluated in accordance with this section. Where there is no separation between the mixed occupancies or the separation between mixed occupancies does not qualify for any of the categories indicated in Section 3413.1.6.16.1, the building shall be evaluated as indicated in Section 3413.1.6, and the value for mixed occupancies shall be zero. Under the categories and occupancies in Table 3413.1.6.16, determine the appropriate value and enter that value into Table 3413.1.7 under Safety Parameters 3413.1.6.16, Mixed Occupancies, for fire safety and general safety. For buildings without mixed occupancies, the value shall be zero. *Facilities* in Group I-2 occupancies meeting Category a shall be considered to fail the evaluation.

**TABLE 3413.1.6.16
MIXED OCCUPANCY VALUES^a**

OCCUPANCY	CATEGORIES		
	a	b	c
A-1, A-2, R	-10	0	10
A-3, A-4, B, E, F, M, S	-5	0	5
I-2	NP	0	5

NP = Not Permitted.

a. For fire-resistance ratings between categories, the value shall be obtained by linear interpolation.

3413.1.6.16.1 Categories. The categories for mixed occupancies are:

1. Category a—Occupancies separated by minimum 1-hour *fire barriers* or minimum 1-hour horizontal assemblies, or both.
2. Category b—Separations between occupancies in accordance with Section 508.4.
3. Category c—Separations between occupancies having a *fire-resistance rating* of not less than twice that required by Section 508.4.

3413.1.6.17 Automatic sprinklers. Evaluate the ability to suppress or control a fire based on the installation of an *automatic sprinkler system* in accordance with Section 903.3.1. “Required sprinklers” shall be based on the requirements of this code. Under the categories and occupancies in Table 3413.1.6.17, determine the appropriate value and enter that value into Table

3413.1.7 under Safety Parameters 3413.1.6.17, Automatic Sprinklers, for fire safety, *means of egress* divided by 2, and general safety. *High-rise buildings* defined in Chapter 2 that undergo a *change of occupancy* to Group R shall be equipped throughout with an *automatic sprinkler system* in accordance with Section 403 and Chapter 9. *Facilities* in Group I-2 occupancies meeting Category a, b, c or f shall be considered to fail the evaluation.

**TABLE 3413.1.6.17
SPRINKLER SYSTEM VALUES**

OCCUPANCY	CATEGORIES					
	a ^a	b _a	c	d	e	f
A-1, A-3, F, M, R, S-1	-6	-3	0	2	4	6
A-2	-4	-2	0	1	2	4
A-4, B, E, S-2	-12	-6	0	3	6	12
I-2	NP	NP	NP	8	10	NP

NP = Not Permitted.

a. These options cannot be taken if Category a in Section 3413.1.6.17.1 is used.

3413.1.6.17.1 Categories. The categories for *automatic sprinkler system* protection are:

1. Category a—An *approved automatic sprinkler system* is required throughout; an *approved automatic sprinkler system* is not provided.
2. Category b—An *approved automatic sprinkler system* is required in a portion of a building; an *approved automatic sprinkler system* is not provided; the sprinkler system design is not adequate for the hazard protected in accordance with Chapter 9.
3. Category c—An *approved automatic sprinkler system* is not required; none are provided.
4. Category d—An *approved automatic sprinkler system* is required in a portion of a building; an *approved automatic sprinkler system* is provided in a portion of a building in accordance with Chapter 9.
5. Category e—An *approved automatic sprinkler system* is required throughout; an *approved automatic sprinkler system* is provided throughout in accordance with Chapter 9.
6. Category f—An *approved automatic sprinkler system* is not required throughout; an *approved automatic sprinkler system* is provided throughout in accordance with Chapter 9.

3413.1.6.18 Standpipes. Evaluate the ability to initiate attack on a fire by making a supply of water readily available through the installation of standpipes in accordance with Section 905. “Required Standpipes” shall be based on the requirements. Under the categories and occupancies in Table 3413.1.6.18, determine the appropriate value and enter that value into Table 3413.1.7 under Safety Parameters 3413.1.6.18, Standpipes, for fire safety, *means of egress* and general safety.

**TABLE 3413.1.6.18
STANDPIPE SYSTEM VALUES**

OCCUPANCY	CATEGORIES			
	aa	b	c	d
A-1, A-3, F, M, R, S-1	-6	0	4	6
A-2	-4	0	2	4
A-4, B, E, S-2	-12	0	6	12
I-2	-2	0	1	2

a. This option cannot be taken if Category a or Category b in Section 3413.1.6.18 is used.

3413.1.6.18.1 Standpipe categories. The categories for standpipe systems are:

1. Category a—Standpipes are required; standpipe is not provided or the standpipe system design is not in compliance with Section 905.3.
2. Category b—Standpipes are not required; none are provided.
3. Category c—Standpipes are required; standpipes are provided in accordance with Section 905.
4. Category d—Standpipes are not required; standpipes are provided in accordance with Section 905.

3413.1.6.19 Incidental uses. Evaluate the protection of incidental uses in accordance with Section 509.4.2. Do not include those where this code requires *automatic sprinkler systems* throughout the building including covered *mall and open mall buildings, high-rise buildings*, public garages and unlimited area buildings. Assign the lowest score from Table 3413.1.6.19 for the building or floor area being evaluated and enter that value into Table 3413.1.7 under Safety Parameters 3413.1.6.19, Incidental Uses, for fire safety, *means of egress* and general safety. If there are no specific occupancy areas in the building or floor area being evaluated, the value shall be zero.

**TABLE 3413.1.6.19
INCIDENTAL USE AREA VALUES**

PROTECTION REQUIRED BY TABLE 509.1	PROTECTION PROVIDED						
	None	1 hour	AS	AS with CRS	1 hour and AS	2 hours	2 hours and AS
2 hours and AS	-4	-3	-2	-2	-1	-2	0
2 hours, or 1 hour and AS	-3	-2	-1	-1	0	0	0
1 hour and AS	-3	-2	-1	-1	0	-1	0
1 hour	-1	0	-1	-1	0	0	0
1 hour, or AS with CRS	-1	0	-1	-1	0	0	0
AS with CRS	-1	-1	-1	-1	0	-1	0
1 hour or AS	-1	0	0	0	0	0	0

AS = Automatic Sprinkler System.

CRS = Construction capable of resisting the passage of smoke (see Section 3405.9.4.2).

3413.1.6.20 Smoke compartmentation. Evaluate the *smoke compartments* for compliance with Section 407.5. Under the categories and occupancies in Table

3413.1.6.20, determine the appropriate smoke compartmentation value (SCV) and enter that value into Table 3413.1.7 under Safety Parameters 3413.1.6.20, Smoke Compartmentation, for fire safety, *means of egress* and general safety. Facilities in Group I-2 occupancies meeting Category b or c shall be considered to fail the evaluation.

**TABLE 3413.1.6.20
SMOKE COMPARTMENTATION VALUES**

OCCUPANCY	CATEGORIES ^a		
	a	b	c
A, B, E, F, M, R and S	0	0	0
I-2	0	-10	NP

NP = Not Permitted.

a. For areas between categories, the smoke compartmentation value shall be obtained by linear interpolation.

3413.1.6.20.1 Categories. Categories for *smoke compartment* size are:

1. Category a—*Smoke compartment* complies with Section 407.5.
2. Category b—*Smoke compartment* are provided but do not comply with Section 407.5.
3. Category c—*Smoke compartments* are not provided.

3413.1.6.21 Care recipient ability, concentration, smoke compartment location and ratio to attendant. In I-2 occupancies, the ability of care recipients, their concentration and ratio to attendants shall be evaluated and applied in accordance with this section. Evaluate each *smoke compartment* using the categories in Sections 3413.1.6.21.1, 3413.1.6.21.2 and 3413.1.6.21.3 and enter the value in Table 3413.1.7. To determine the safety factor, multiply the three values together; if the product is less than 6, compliance has failed.

3413.1.6.21.1 Care recipient ability for self-preservation. Evaluate the ability of the care recipients for self-preservation in each *smoke compartment* in an emergency. Under the categories and occupancies in Table 3413.1.6.21.1, determine the appropriate value and enter that value in Table 3413.1.7 under Safety Parameters 3413.1.6.21.1, Care Recipient Ability for Self-preservation, for *means of egress* and general safety.

**TABLE 3413.1.6.21.1
CARE RECIPIENT ABILITY VALUES**

OCCUPANCY	CATEGORIES		
	a	b	c
I-2	3	2	1

3413.1.6.21.1.1 Categories. The categories for care recipient ability for self-preservation are:

1. Category a—(mobile) Care recipients are capable of self-preservation without assistance.

2. Category b—(not mobile) Care recipients rely on assistance for evacuation or relocation.
3. Category c—(not movable) Care recipients cannot be evacuated or relocated.

3413.1.6.21.2 Care recipient concentration. Evaluate the concentration of care recipients in each *smoke compartment* under Section [3413.1.6.21.2](#). Under the categories and occupancies in Table [3413.1.6.21.2](#) determine the appropriate value and enter that value in Table [3413.1.7](#) under Safety Parameters [3413.1.6.21.2](#), Care Recipient Concentration, for *means of egress* and general safety.

**TABLE 3413.1.6.21.2
CARE RECIPIENT CONCENTRATION VALUES**

OCCUPANCY	CATEGORIES		
	a	b	c
I-2	3	2	1

3413.1.6.21.2.1 Categories. The categories for care recipient concentration are:

1. Category a—*smoke compartment* has 1 to 10 care recipients.
2. Category b—*smoke compartment* has more than 10 to 40 care recipients.
3. Category c—*smoke compartment* has more than 40 care recipients.

3413.1.6.21.3 Attendant-to-care recipients ratio. Evaluate the attendant-to-care recipients ratio for each compartment under Section [3413.1.6.21.3](#). Under the categories and occupancies in Table [3413.1.6.21.3](#), determine the appropriate value and enter that value in Table [3413.1.7](#) under Safety Parameters [3413.1.6.21.3](#), Attendant-to-Care Recipients Ratio, for *means of egress* and general safety.

**TABLE 3413.1.6.21.3
ATTENDANT-TO-CARE RECIPIENTS RATIO VALUES**

OCCUPANCY	CATEGORIES		
	a	b	c
I-2	3	2	1

3413.1.6.21.3.1 Categories. The categories for attendant-to-care recipient concentrations are:

1. Category a—attendant-to-care recipients concentration is 1:5 or no care recipients.
2. Category b—attendant-to-care recipients concentration is 1:6 to 1:10.
3. Category c—attendant-to-care recipients concentration is greater than 1:10.

3413.1.7 Building score. After determining the appropriate data from Section [3413.1.6](#), enter those data

in Table [3413.1.7](#) and total the building score.

3413.1.8 Safety scores. The values in Table [3413.1.8](#) are the required mandatory safety scores for the evaluation process listed in Section [3413.1.6](#).

**TABLE 3413.1.8
MANDATORY SAFETY SCORES^a**

OCCUPANCY	FIRE SAFETY (MFS)	MEANS OF EGRESS (MME)	GENERAL SAFETY (MGS)
A-1	20	31	31
A-2	21	32	32
A-3	22	33	33
A-4, E	29	40	40
B	30	40	40
F	24	34	34
I-2	19	34	34
M	23	40	40
R	21	38	38
S-1	19	29	29
S-2	29	39	39

a. MFS = Mandatory Fire Safety.
MME = Mandatory Means of Egress.
MGS = Mandatory General Safety.

3413.1.9 Evaluation of building safety. The mandatory safety score in Table [3413.1.8](#) shall be subtracted from the building score in Table [3413.1.7](#) for each category in accordance with the evaluation formulas in Table [3413.1.9](#). Where the final score for any category equals zero or more, the building is in compliance with the requirements of this section for that category. Where the final score for any category is less than zero, the building is not in compliance with the requirements of this section.

3413.1.9.1 Mixed occupancies. For mixed occupancies, the following provisions shall apply:

1. Where the separation between mixed occupancies does not qualify for any category indicated in Section [3413.1.6.16](#), the mandatory safety scores for the occupancy with the lowest general safety score in Table [3413.1.8](#) shall be utilized (see Section [3413.1.6](#)).
2. Where the separation between mixed occupancies qualifies for any category indicated in Section [3413.1.6.16](#), the mandatory safety scores for each occupancy shall be placed against the evaluation scores for the appropriate occupancy. An evaluation is not required for areas of the building with separated occupancies in accordance with Table 508.4 in which there are no *alterations* or *change of occupancy*.

TABLE 3413.1.7
SUMMARY SHEET—BUILDING CODE

Existing occupancy: _____		Proposed occupancy: _____	
Year building was constructed: _____		Number of stories: _____ Height in feet: _____	
Type of construction: _____		Area per floor: _____	
Percentage of open perimeter increase: _____ %			
Completely suppressed: _____		Yes _____ No _____	
		Corridor wall rating: _____	
		Type: _____	
Compartmentation: _____		Yes _____ No _____	
		Required door closers: _____	
		Yes _____ No _____	
Fire-resistance rating of vertical opening enclosures: _____			
Type of HVAC system: _____, serving number of floors: _____			
Automatic fire detection: _____		Yes _____ No _____	
		Type and location: _____	
Fire alarm system: _____		Yes _____ No _____	
		Type: _____	
Smoke control: _____		Yes _____ No _____	
		Type: _____	
Adequate exit routes: _____		Yes _____ No _____	
		Dead ends: _____	
		Yes _____ No _____	
Maximum exit access travel distance: _____		Elevator controls: _____	
		Yes _____ No _____	
Means of egress emergency lighting: _____		Yes _____ No _____	
		Mixed occupancies: _____	
		Yes _____ No _____	
Standpipes: _____		Yes _____ No _____	
		Care recipients ability for self-preservation: _____	
Incidental use: _____		Yes _____ No _____	
		Care recipients concentration: _____	
Smoke compartmentation less than 22,500 sq. feet (2092 m ²): _____		Yes _____ No _____	
		Attendant-to-care recipients ratio: _____	
SAFETY PARAMETERS		FIRE SAFETY (FS)	
MEANS OF EGRESS (ME)		GENERAL SAFETY (GS)	
3413.1.6.1 Building height			
3413.1.6.2 Building area			
3413.1.6.3 Compartmentation			
3413.1.6.4 Tenant and dwelling unit separations			
3413.1.6.5 Corridor walls			
3413.1.6.6 Vertical openings			
3413.1.6.7 HVAC systems			
3413.1.6.8 Automatic fire detection			
3413.1.6.9 Fire alarm system			
3413.1.6.10 Smoke control		****	
3413.1.6.11 Means of egress		****	
3413.1.6.12 Dead ends		****	
3413.1.6.13 Maximum exit access travel distance		****	
3413.1.6.14 Elevator control			
3413.1.6.15 Means of egress emergency lighting		****	
3413.1.6.16 Mixed occupancies			****
3413.1.6.17 Automatic sprinklers			÷ 2 =
3413.1.6.18 Standpipes			
3413.1.6.19 Incidental use			
3413.1.6.20 Smoke compartmentation			
3413.1.6.21.1 Care recipients' ability for self-preservation		****	
3413.1.6.21.2 Care recipients concentration ^a		****	
3413.1.6.21.3 Attendant-to-care recipients ratio ^a		****	
Building score—total value			

***No applicable value to be inserted.
a. Only applicable to Group I-2 occupancies.

TABLE 3413.1.9
EVALUATION FORMULAS^a

FORMULA	TABLE 3413.1.7	TABLE 3413.1.8		SCORE	PASS	FAIL
FS – MFS ≥ 0	____ (FS) –	____ (MFS)	=	_____	_____	_____
ME – MME ≥ 0	____ (ME) –	____ (MME)	=	_____	_____	_____
GS – MGS ≥ 0	____ (GS) –	____ (MGS)	=	_____	_____	_____

- a. FS = Fire Safety.
 GS = General Safety.
 ME = Means of Egress.
 MFS = Mandatory Fire Safety.
 MGS = Mandatory General Safety.
 MME = Mandatory Means of Egress.

Section 3414 Relocated or Moved Buildings

3414.1. General. Relocated or moved buildings shall comply with Section 3403.1.4.

Section 3415 Construction Safeguards

3415.1 General. Construction safeguards shall be in accordance with Chapter 33.

CHAPTER 35

REFERENCED STANDARDS

~~ALI~~ ALI ALCTV—2017: Standard for Automotive Lifts—Safety Requirements for Construction, Testing and Validation (ANSI)

~~AMCA~~ 540—13: Test Method for Louvers Impacted by Wind Borne Debris

ANSI

- ~~A13.1—2020: Scheme for the Identification of Piping Systems~~
- [A118.15—19: American National Standard Specifications for Improved Modified Dry-Set Cement Mortar](#) 2103.2.4
- [E1.21—20: Entertainment Technology](#) 3113.1, 3113.3

ASCE/SEI

- 7—16 with Supplements [1](#), [2](#) and [3](#): Minimum Design Loads and Associated Criteria for Buildings and Other Structures
- [41—2017: Seismic Evaluation and Retrofit of Existing Buildings](#) 3403.4.3.1, Table 3403.4.3.1, 3403.4.3.2, Table 3403.4.3.2

ASHRAE

- [15—2019: Safety Standard for Refrigeration Systems](#) 2802.8.2

ASME

- ~~A17.1—2019/CSA B44—19: Safety Code for Elevators and Escalators~~
- ~~A17.7—2007/CSA B44—07(R2017): Performance based Safety Code for Elevators and Escalators~~
- ~~A90.1—2015: Safety Standard for Belt Manlifts~~
- ~~B31.3—2020: Process Piping~~

ASTM

- [C494—17: Standard Specification for Chemical Admixtures for Concrete](#) 202
- [C1193—11: Standard Guide for Use of Joint Sealants](#) 1811.2.3.2.1
- ~~D323—15A: Test Method for Vapor Pressure of Petroleum Products (Reid Method)~~ 202
- [E154—08: Standard Test Methods for Water Vapor Retarders Used in Contact with Earth under Concrete Slabs, on Walls, or as Ground Cover](#) 1811.2.2.1
- ~~E283—04(2012): Standard Test Method for Determining Rate of Air Leakage through Exterior Windows, Curtain Walls and Doors Under Specified Pressure Differences across the Specimen~~
- [E580/E580M—14: Standard Practice for Installation of Ceiling Suspension Systems for Acoustical Tile and Lay-in Panels in Areas Subject to Earthquake Ground Motions](#) 1613.4.12
- ~~E1529—16e1: Standard Test Method for Determining Effects of Large Hydrocarbon Pool Fires on Structural Members and Assemblies~~ 202, 444.4.1.7.1.3
- [E1745—17: Standard Specification for Plastic Water Vapor Retarders Used in Contact with Soil or Granular Fill under Concrete Slabs](#) 1811.2.2.1
- ~~E1886—2013A: Standard Test Method for Performance of Exterior Windows, Curtain Walls, Doors and Impact Protective Systems Impacted by Missile(s) and Exposed to Cyclic Pressure Differentials~~
- ~~E1996—2017: Specification for Performance of Exterior Windows, Curtain Walls, Doors and Impact aProtective Systems Impacted by Windborne Debris in Hurricanes~~
- ~~E2178—13: Standard Test Method for Air Permeance of Building Materials~~

CGA Compressed Gas Association 14501 George Carter Way, Suite 103, Chantilly, VA 20151

- [ANSI/CGA G-13— \(2016\): Storage and Handling of Silane and Silane Mixtures \(an American National Standard\) 451.4, 451.5.2](#)
- [ANSI/CGA P-18— \(2013\): Standard for Bulk Inert Gas Systems 442.1](#)
- [C-7— \(2014\): Guide to Classification and Labeling of Compressed Gases 442.4.2](#)

CPSC

- [16 CFR Part 1500.41—2009: Method for Testing Primary Irritant Substances 202](#)
- [16 CFR Part 1500.42—2009: Test for Eye Irritants 202](#)

CSA

- [ASME A17.1— 2019/CSA B44— 2019: Safety Code for Elevators and Escalators](#)
- [ASME A17.7— 2007/CSA B44.7— 07\(R2017\): Performance based Safety Code for Elevators and Escalators](#)

DASMA

- [ANSI/DASMA 115— 2017: Standard Method for Testing Sectional Garage Doors, Rolling Doors and Flexible Doors: Determination of Structural Performance Under Missile Impact and Cyclic Wind Pressure](#)

DOTy

[U.S. Department of Treasury, c/o Superintendent of Documents, U.S. Government Printing Office, Washington, DC 20402-9325](#)

- [27 CFR Part 55—2015: Commerce in Explosives, as amended through April 1, 1998, 202](#)

FEMA

- [FEMA TB 11— 01: Crawlspace Construction for Buildings Located in Special Flood Hazard Areas](#)

ICC

- [IEBC— 21: International Existing Building Code®](#)
- [IECC— 21: International Energy Conservation Code®](#)
- [IFC— 21: International Fire Code®](#)
- [IFGC— 21: International Fuel Gas Code®](#)
- [IMC— 21: International Mechanical Code®](#)
- [IPC— 21: International Plumbing Code®](#)
- [IPMC— 21: International Property Maintenance Code®](#)
- [IPSDC— 21: International Private Sewage Disposal Code®](#)
- [IRC— 21: International Residential Code®](#)
- [IWUIC— 21: International Wildland Urban Interface Code®](#)

MHI

- [ANSI MH29.1— 2012: Safety Requirements for Industrial Scissors Lifts](#)

NFPA

- [02—19: Hydrogen Technologies Code 406.7.7.1.1, 406.8.6, 406.8.6.1, 406.8.6.8, 429.2, 429.3, 440.1, 445.1](#)
- [10— 2018: Standard for Portable Fire Extinguishers](#)

- [15—17: Standard for Water Spray Fixed Systems for Fire Protection 430.7.5, 438.6](#)
- [30B—19: Code for the Manufacture and Storage of Aerosol Products 439.1, 439.3, 439.4, Table 439.6.1, Table 439.6.2, Table 439.6.2.2, 439.6.3, 439.7.1, 439.8.2, 439.9, 439.11.2, 439.12.1.2, 439.12.1.4, 439.12.2.2, Table 439.12.3, 439.12.4.1, 439.14.4.6, 439.12.4.7, 439.13](#)
- [33—18: Standard for Spray Application Using Flammable or Combustible Materials..... 416.3.2.3](#)
- [34—18: Standard for Dipping, Coating and Printing Processes Using Flammable or Combustible Liquids..... 416.4.2, 416.4.3.2](#)
- [35—16: Standard for the Manufacture of Organic Coatings 418.12.2](#)
- [52—19: Vehicular Gaseous Fuel System Code 440.1](#)
- [55—19: Compressed Gases and Cryogenic Fluids Code 440.1, 440.10.1.2, 442.1, 450.1](#)
- [59A—19: Standard for the Production, Storage and Handling of Liquefied Natural Gas \(LNG\) 440.1, 442.1](#)
- [68—13: Standard on Explosion Protection by Deflagration Venting Table 426.1, 919.1, 919.4](#)
- [69—19: Standard on Explosion Prevention Systems Table 426.1, 919.1, 919.3](#)
- [70—20: National Electrical Code](#)
- [76—16: Standard for the Fire Protection of Telecommunications Facilities 430.7.1, 430.7.2, 430.7.3, 430.7.5, 430.8.2.3, Table 430.8, Table 430.9](#)
- [77—14: Recommended Practice on Static Electricity Table 426.1](#)
- [85—19: Boiler and Combustion System Hazards Code](#)
- [86—19: Standard for Ovens and Furnaces 434.1](#)
- [96—17: Standard for Ventilation Control and Fire Protection of Commercial Cooking Operations 904.13](#)
- [232—17: Standard for the Protection of Records 435.15.1](#)
- [307—20: Standard for the Construction and Fire Protection of Marine Terminals, Piers, and Wharves 903.2.11.7](#)
- [318—18: Standard for the Protection of Semiconductor Fabrication Facilities 415.11.14](#)
- [400—19: Hazardous Materials Code 450.3.2, Table 450.3.5\(1\), Table 450.3.5\(2\)](#)
- [495—18: Explosive Materials Code 202, 443.2, 443.3, 443.3.4.2.1, 919.1, 919.5](#)
- [780—17: Standard for the Installation of Lightning Protection Systems 456.5](#)
- [853—20: Installation of Stationary Fuel Cell Power Systems 429.2, 429.3, 429.5.2, 429.9, 429.10](#)
- [1126—21: Standard for the Use of Pyrotechnics Before a Proximate Audience 443.2](#)

UL

- [30—1995: Metal Safety Cans—with revisions through June 2014 414.21, 415.13.10, 444.4.1.3](#)
- [80—2007: Steel Tanks for Oil-burner Fuels and Other Combustible Liquids—with revisions through January 2014 444.9.1, 2802.1.1.1](#)
- [142—2006: Steel Aboveground Tanks for Flammable and Combustible Liquids—with revisions through August 2014 444.9.1, 2802.1.1.1](#)
- [181—13: Standard for Safety Factory-Made Air Ducts and Connectors 1811.2.5.2, 1812.2.6.2](#)
- [499—2014: Standard for Electrical Heating Appliances—with revisions through February 2017 444.9.5](#)
- [900—2015: Air Filter Units 416.3.5.1](#)
- [1275—2014: Flammable Liquid Storage Cabinets—with revisions through February 2018 414.14.1, 444.4.2.1.1](#)
- [1313—2015: Nonmetallic Safety Cans for Petroleum Products 414.21](#)
- [1973—2018: Batteries for Use in Stationary, Vehicle Auxiliary Power and Light Electric Rail \(LER\) Applications and Stationary Applications Table 430.8](#)
- [2085—97: Protected Above-ground Tanks for Flammable and Combustible Liquids—with revisions through September 2010 202, 406.7.3, 444.4.1.5.4, 444.4.1.7.1.3, 444.4.1.7.5.4, 2802.1.1.1](#)
- [2152—2016: Outline of Investigation for Special Purpose Nonmetallic Containers and Tanks for Specific Combustible or Noncombustible Liquids 444.9.2](#)
- [2196—2017: Standard for Fire Test for Circuit Integrity of Fire Resistive Power, Instrumentation, Control and Data Cables](#)
- [2208—2010: Solvent Distillation Units—with revisions through September 2015 444.5.3.1](#)
- [2245—2006: Below-grade Vaults for Flammable Liquid Storage Tanks 444.4.1.6.1](#)
- [2335—2010: Fire Tests of Storage Pallets—with revisions through August 2017 435.6.1.1](#)
- [2360—2000: Test Methods for Determining the Combustibility Characteristics of Plastics Used in Semi-conductor Tool Construction—with revisions through October 2017 415.11.1.13.1.2, 918.2](#)
- [9540—2016: Standard for Energy Storage Systems and Equipment 430.11.1](#)
- [9540A—2017: Standard for Safety Test Method for Evaluating Thermal Runaway Fire Propagation in Battery Energy Storage Systems 430.5, 430.8.3](#)

USC

- ~~18 USC Part 1, Ch. 40: Importation, Manufacture, Distribution and Storage of Explosive Materials~~

APPENDICES

A—Employee Qualifications

Appendix A is not adopted by the State of Oregon, Building Codes Division, as part of this code. The regulation of this subject matter is outside the statutory authority of this code. Local *municipalities* may not regulate these matters under the authority of this code. A *municipality* may have authority outside of this code to regulate these matters locally, where not preempted.

The provisions in IBC Appendix A are deleted.

B—Board of Appeals

Appendix B is not adopted by the State of Oregon, Building Codes Division, as part of this code. The subject matter in this appendix is preempted by the state building code and may not be adopted by a *municipality*.

The provisions in IBC Appendix B are deleted.

C—Group U Agricultural Buildings

Section C101 General

IBC C101.1 **C101.1 Scope.** ~~The provisions of this appendix shall apply exclusively to agricultural buildings. Agricultural buildings, equine facilities and dog training facilities meeting the parameters of ORS 455.315 (1) and (2) are exempt from this code, including submission of plans and permits. The provisions of this appendix shall apply exclusively to regulated agricultural buildings that are not exempted by ORS 455.315.~~ Such regulated buildings shall be classified as Group U and shall include, but not be limited to, the following uses:

(Items 1 – 8 remain unchanged)

ORS 455.315 is not a part of this code but is reprinted here for the reader's convenience:

455.315 Exemption of agricultural buildings, agricultural grading, equine facilities and dog training facilities.

(1) The provisions of this chapter do not authorize the application of a state structural specialty code to any agricultural building, agricultural grading, equine facility or dog training facility.

(2) As used in this section:

(a)(A) "Agricultural building" means a structure located on a farm or forest operation and used for: (i) Storage, maintenance or repair of farm or forestry machinery and equipment; (ii) The raising, harvesting and selling of crops or forest products; (iii) The feeding, breeding, management and sale of, or the produce of, livestock, poultry, fur-bearing animals or honeybees; (iv) Dairying and the sale of dairy products; or (v) Any other agricultural, forestry or horticultural use or animal husbandry, or any combination thereof, including the preparation and storage of the produce raised on the farm for human use and animal use, the preparation and storage of forest products and the disposal, by marketing or otherwise, of farm produce or forest products.

(B) "Agricultural building" does not mean: (i) A dwelling; (ii) A structure used for a purpose other than growing plants in which 10 or more persons are present at any one time; (iii) A structure regulated by the State Fire Marshal pursuant to ORS chapter 476; (iv) A structure used by the public; or (v) A structure subject to sections 4001 to 4127, title 42, USC (the National Flood Insurance Act of 1968) as amended, and regulations promulgated thereunder.

(b) "Agricultural grading" means grading related to a farming practice as defined in ORS 30.930.

(c) "Dog training facility" means a farm building used for dog training classes or testing trials permitted under ORS 215.213 (1)(z) or 215.283 (1)(x) in which no more than 10 persons are present at any one time.

(d)(A) "Equine facility" means a building located on a farm and used by the farm owner or the public for: (i) Stabling or training equines; or (ii) Riding lessons and training clinics.

(B) "Equine facility" does not mean: (i) A dwelling; (ii) A structure in which more than 10 persons are present at any one time; (iii) A structure regulated by the State Fire Marshal pursuant to ORS chapter 476; or (iv) A structure subject to sections 4001 to 4127, title 42, United States Code (the National Flood Insurance Act of 1968) as amended, and regulations promulgated thereunder.

(3) Notwithstanding the provisions of subsection (1) of this section, incorporated cities may regulate agricultural buildings, equine facilities and dog training facilities within their boundaries pursuant to this chapter.

(4) An agricultural building may be used for uses in addition to the uses listed in subsection (2)(a)(A) of this section if the additional uses:

(a) Are incidental and accessory to the uses listed in subsection (2)(a)(A) of this section; (b) Are personal to the farm owner and the farm owner's immediate family or household; and (c) Do not pose a greater hazard to persons or property than the uses listed in subsection (2)(a)(A) of this section.

D—Fire Districts

Appendix D is not adopted by the State of Oregon, Building Codes Division, as part of this code. The regulation of this subject matter is outside the statutory authority of this code. Local *municipalities* may not regulate these matters under the authority of this code. A *municipality* may have authority outside of this code to regulate these matters locally, where not preempted.

The provisions in IBC Appendix D are deleted.

E—Supplementary Accessibility Requirements

Appendix E is not adopted by the State of Oregon, Building Codes Division, as part of this code. The subject matter in this appendix is preempted by the state building code and may not be adopted by a *municipality*.

The provisions in IBC Appendix E are deleted.

F—Rodentproofing

Appendix F is not adopted as part of the state building code, but may be adopted through local ordinance by a local *municipality*.

The rest of Appendix F remains unchanged.

G—Flood-Resistant Construction

Appendix G is not adopted by the State of Oregon, Building Codes Division, as part of this code. The regulation of this subject matter is outside the statutory authority of this code. Local *municipalities* may not regulate these matters under the authority of this code. A *municipality* may have authority outside of this code to regulate these matters locally, where not preempted.

The provisions in IBC Appendix G are deleted.

H—Signs

Appendix H is not adopted as part of the *state building code*, but may be adopted through local ordinance by a local *municipality*.

The rest of Appendix H remains unchanged.

I—Patio Covers

IBC Appendix I remains unchanged.

J—Grading

Appendix J is not adopted by the State of Oregon, Building Codes Division, as part of this code. The regulation of this subject matter is outside the statutory authority of this code. Local *municipalities* may not regulate these matters under the authority of this code. A *municipality* may have authority outside of this code to regulate these matters locally, where not preempted.

The provisions in IBC Appendix J are deleted.

K—Administrative Provisions

Appendix K is not adopted by the State of Oregon, Building Codes Division, as part of this code. The subject matter in this appendix is preempted by the *state building code* and may not be adopted by a *municipality*.

The provisions in IBC Appendix K are deleted.

L—Earthquake Recording Instrumentation

Appendix L is not adopted by the State of Oregon, Building Codes Division, as part of this code. The subject matter in this appendix is preempted by the *state building code* and may not be adopted by a *municipality*.

The provisions in IBC Appendix L are deleted.

M—Tsunami-Generated Flood Hazards

Appendix M is not adopted by the State of Oregon, Building Codes Division, as part of this code. The subject matter in this appendix is preempted by the *state building code* and may not be adopted by a *municipality*.

The provisions in IBC Appendix M are deleted.

N—Replicable Buildings

Appendix N is not adopted by the State of Oregon, Building Codes Division, as part of this code. The subject matter in this appendix is preempted by the *state building code* and may not be adopted by a *municipality*.

The provisions in IBC Appendix N are deleted.

O—Performance-Based Application

Section O101 General

IBC O101.1 **O101.1 Introduction.** The following ~~administrative~~ provisions are excerpted from the *ICC Performance Code for Buildings and Facilities* and ~~can~~ may be used in conjunction with the Alternate Methods provisions in Chapter 1, or for a review of submittals requiring a rational analysis or performance-based design, where requested by the permit applicant in accordance with Chapter 1. ~~These provisions provide an established framework for the building official in terms of the design expertise needed, the necessary submittals, a review framework and related items.~~

IBC O101.2 **O101.2 Qualifications.** ~~Reserved.~~

IBC O101.3 **O101.3 Construction document preparation.** *Construction documents* required by this ~~code~~ appendix and Chapter 1 shall be prepared in adequate detail and submitted for review and approval in accordance with Section 107.

O101.3.1 Review. *Construction documents* submitted in accordance with this ~~code~~ appendix and Chapter 1 shall be reviewed for code compliance with the appropriate code provisions in accordance with Section 107.

IBC 101.4 **O101.4 Construction.** Construction shall comply with the *approved construction documents* submitted in accordance with this ~~code~~ appendix and Chapter 1, and shall be verified and *approved* to demonstrate compliance with this code.

O101.4.1 Facility operating policies and procedures. *Not adopted*

O101.4.2 Maintenance. *Not adopted*

O101.4.3 Changes. *Not adopted*

IBC O101.5 **O101.5 Documentation.** The *registered design professional* shall prepare appropriate documentation for the project, clearly detailing the approach and rationale for the design submittal and the construction ~~and the future use~~ of the building, facility or process.

O101.5.1 Reports ~~and manuals~~. The design report shall document the steps taken in the design analysis, clearly identifying the criteria, parameters, inputs, assumptions, sensitivities and limitations involved in the analysis. The design report shall clearly identify bounding conditions, assumptions and sensitivities that clarify the expected uses and limitations of the performance analysis. This report shall verify that the design approach is in compliance with the applicable codes and acceptable methods and shall be submitted for concurrence by the *building official* prior to the construction documents being completed. The report shall document the design features to be incorporated based on the analysis.

The design report shall address the following: *(1 through 9, and 14 through 15 remain unchanged)*

10. System design ~~and operational requirements.~~

~~11. Operational and maintenance requirements.~~

~~12. Commissioning testing requirements and acceptance criteria.~~

~~13. Frequency of certificate renewal.~~

O101.5.2 Design submittal. Applicable *construction documents* shall be submitted to the *building official* for review. The documents shall be submitted in accordance with [Chapter 1](#) and the *municipality's jurisdiction's* procedures and in sufficient detail to obtain appropriate *permits*.

IBC O101.6 **O101.6 Review.** *Construction documents* submitted in accordance with this code shall be reviewed for code compliance with the appropriate code provisions [in accordance with Chapter 1](#).

~~O101.6.2 Costs.~~ *Not adopted*

IBC O101.7 **O101.7 Permits.** Prior to the start of construction, appropriate *permits* shall be obtained in accordance with [the state building code and](#) the *municipality's jurisdiction's* procedures ~~and applicable codes~~.

IBC O101.8 **O101.8 Verification of compliance.** Upon completion of the project, documentation shall be ~~prepared~~ [submitted](#) that verifies performance and prescriptive code provisions have been met. Where required by the *building official*, the *registered design professional* shall ~~file~~ [submit](#) a report that verifies bounding conditions are met.

IBC O101.9 **O101.9 Extent of documentation.** *Not adopted*

IBC O101.8 **O101.10 Analysis of change.** *Not adopted*

BEFORE THE PUBLIC UTILITY COMMISSION
OF OREGON

Docket PCN 5

In the Matter of

IDAHO POWER COMPANY'S
PETITION FOR CERTIFICATE OF PUBLIC CONVENIENCE
AND NECESSITY

Surrebuttal Testimony of Joseph Stippel

Exhibit 1903

Excerpt from Myers Data Response – Narrative Describing Figure 31

April 7, 2023

METHODOLOGY FOR CONDUCTING EXTREME EVENT MODEL SIMULATIONS

Prepared by
G&E Engineering Systems Inc.
California

Principal Investigator
John Eiding, P.E., S.E.

September 2015

3.0 SAMPLE ANALYSIS 1: WIND EVENT

In Section 3, we present a reliability analysis for a 230 kV transmission line that failed in 1999 in a high wind event. This line is owned by the Bonneville Power Administration (BPA).

BPA has had a number of towers collapse due to high wind and ice loads. For the period from 1950 to 2009, a total of 161 towers were damaged due to high winds, and another 61 towers damaged due to ice loads (Figure 3-1). Of these, there have been a few cases where the damage was a broken conductor (under 3% of the time). In some cases the damage was dropping the conductor due to failure of the porcelain insulators.

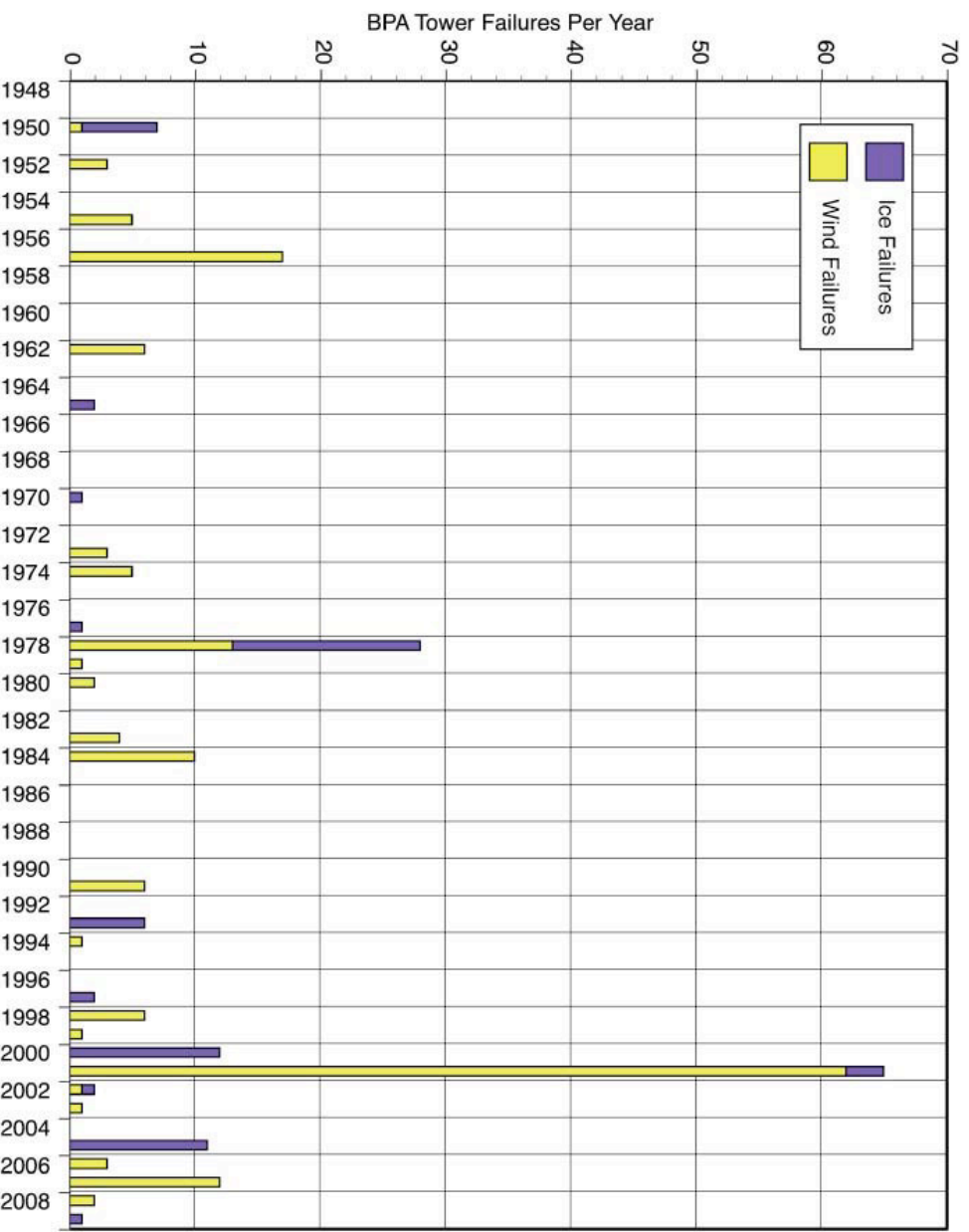


Figure 3-1 Reported Tower Failures (BPA), 1948 - 2009

The data in Figure 3-1 is thought to be nearly complete for steel lattice structures. The data in Figure 3-1 may omit data for damaged wood pole-type structures if the construction crews effected repairs without specifically reporting said repairs to the BPA transmission group. Most of the damage in Figure 3-1 was for towers on 115 kV to 500 kV lines, and could be due to wind- or ice-plus-wind-induced overloads on specific above ground members or foundation failures; in a few cases, the damage was caused by wind-induced fallen trees. Damage due to landslides, snowslides, vehicle impact, airplane impacts or other non-weather related causes is not included in Figure 3-1.

The large number of wind-tower failures in 2001 was on a line near Pasco, where high winds failed 61 towers on one wood pole line (wood poles snapped near their base).

Figure 3-1 does not distinguish between towers that were damaged due to high wind and those adjacent towers that were damaged due to the unbalanced conductor loads that occur once the first tower collapses. With the exception of the one wood-pole event in 2001, it is apparent that unbalanced-load tower failures have not been common (in a few initiations, perhaps 1 or 2 adjacent towers collapsed) in the BPA system. This has not been the case for other high-voltage power utilities. For example, observational failures of Hydro-Quebec's 735 kV towers in the 1998 ice storm suggests that the failure of a single tower along a long circuit led to rapid collapse of every adjacent tower due to unbalanced conductor loads until the pull-down towers reached a dead end tower, or a tower with very short spans (near substations). Elsewhere in the USA and worldwide, it has not been uncommon to see 5, 6 or 7 adjacent towers collapsed in a wind event. It is speculative whether BPA's design practices are sufficiently different from those at other high-voltage transmission utilities such that BPA's steel lattice tower configurations are inherently more resistant to unbalanced line loads, but the BPA empirical evidence of the past 60 years would certainly imply that this is the case.

3.1 Description of the Line

A sample transmission circuit is used in order to perform reliability analyses for wind loads. The single 230 kV circuit is called the Satsop – Aberdeen # 2 line. This line is located in Washington State, near the Pacific Ocean.

This circuit is owned and operated by the Bonneville Power Administration. Detailed information about this circuit may not be released to third parties without the prior written approval by BPA.

This 230 kV circuit is located in western Washington State. Figure 3-2 highlights a portion of the 230 kV transmission network in western Washington State, with the Satsop – Aberdeen # 2 line going between the two noted substations (large triangles).

BEFORE THE PUBLIC UTILITY COMMISSION
OF OREGON

Docket PCN 5

In the Matter of

IDAHO POWER COMPANY'S
PETITION FOR CERTIFICATE OF PUBLIC CONVENIENCE
AND NECESSITY

Surrebuttal Testimony of Joseph Stippel

Exhibit 1904

Report from the National Weather Service on the Enhanced Fujita Scale

April 7, 2023

**A Recommendation for an
ENHANCED FUJITA SCALE
(EF-Scale)**

**Submitted to
The National Weather Service
and
Other Interested Users**

**October 10, 2006
Revision 2**

**WIND SCIENCE AND ENGINEERING CENTER
Texas Tech University
Lubbock, Texas 79409-1023**

A Recommendation for an
ENHANCED FUJITA SCALE
(EF-Scale)

Submitted to
The National Weather Service
and
Other Interested Users

October 10, 2006
Revision 2

WIND SCIENCE AND ENGINEERING CENTER
Texas Tech University
Lubbock, Texas 79409

FOREWORD

This project is conducted under the auspices of the Wind Science and Engineering Center at Texas Tech University. Drs. James R. McDonald and Kishor C. Mehta are Co-PIs on the project. The work was performed under the U.S. Department of Commerce, National Institute of Standards and Technology (NIST)/Texas Tech University Cooperative Agreement Award 70NANB8H0059. Dr. Emil Simiu has NIST technical oversight responsibility.

For the proposed EF Scale to replace the original Fujita Scale it must be acceptable for use by the National Weather Service and many other users. Personnel from the National Weather Service have provided valuable input to the project. Every effort is being made to gain a wide spread consensus from both the engineering and meteorological communities.

Revision 1 dated January 26, 2006 of this report corrected some typos and cleaned up a few inconsistencies in the original document published in June 2004. Revision 2 dated October 10, 2006 clarifies the steps in assigning an EF-Scale rating to a tornado event. DOD descriptions for One- and Two-Family Residences are modified and now include “slab swept clean” in DOD10.

TABLE OF CONTENTS

	Page
Foreword	ii
Table of Contents	iii
List of Figures	iv
List of Tables	v
Introduction	1
Bckground	1
Damage Indicators and Degrees of Damage	2
Expert Elicitation Process	5
Proposed DI's and DOD's for Enhanced Fujita Scale (EF Scale)	6
Corelation of Fujita Scale and EF Scale	9
Proposed EF Scale	11
EF-Scale Protocol	12
Rating an Individual Building, Structure or Other Damage Indicator	12
Rating a Tornado Event	12
Conclusion	13
References	15
Acknowledgments	15
Appendixes	16
A. Twenty-eight Damage Indicators with Photos	
B. Expert Elicitation of Damage versus Wind Speed	
C. Fujita Scale Ratings of DODs by NWS Panel	

LIST OF FIGURES

Figure	Page
1. Correlation of Fujita Scale and EF Scale Wind Speeds10

LIST OF TABLES

Table	Page
1. Steering Committee Members	3
2. Attendees at the Fujita Scale Forum	3
3. Damage Indicators for EF Scale7
4. One- and Two-Family Residences (FR12)8
5. EF-Scale Wind Speed Ranges Derived from Fujita-Scale Ranges	11
6. Recommended EF-Scale Wind Speed Ranges11

Introduction

Dr. Ted Fujita (1971) developed the Fujita Scale to provide a method to rate the intensity of tornadoes. The intent of the scale was to distinguish between weak tornadoes and strong tornadoes. There was a need to be able to rate tornadoes in the historical database as well as future tornadoes as they occur. The meteorological and engineering communities almost immediately accepted the Fujita Scale.

The National Weather Service (NWS) applies the Fujita Scale in rating tornadoes as they occur. Dr. Fujita's group at the University of Chicago and personnel at the National Severe Storms Forecast Center (NSSFC) independently assigned Fujita Scale ratings to tornadoes in the historical records based on written descriptions of the damage. The University of Chicago database has not been kept up to date in recent years. The Storm Prediction Center (SPC) maintained the NSSFC database through 1995. Tornado records since that time are kept at the National Climatic Data Center in Asheville, NC.

Although the Fujita Scale has been in use for 33 years, the limitations of the scale are well known to the users. The primary limitations are a lack of damage indicators, no account of construction quality and variability and no definitive correlation between damage and wind speed. These limitations have led to inconsistent rating of tornadoes and in some cases an overestimate of tornado wind speeds. Thus, there is a need to revisit the concept of the Fujita Scale and to improve and eliminate some of the limitations. The Enhanced Fujita Scale proposed in this document is referred to as the EF Scale to distinguish it from the original Fujita Scale.

Background

NWS personnel, who are responsible for rating tornadoes, have expressed frustrations in applying the Fujita Scale in a consistent and accurate manner. Weak links in a structural system or a slow-moving storm sometimes lead to an over rating of a tornado event. Several technical articles suggest that wind speeds associated with some descriptions of damage are too high. For example a 260 mph wind speed is not required to completely destroy a well constructed house and blow away the debris. The damage occurs at significantly lower wind speeds. Minor et al. (1977) and Phan and Simiu (2003) confirm that F4 and F5 ratings of housing damage overestimate the wind speeds required to produce the damage. In the Fujita Scale, there is a lack of clearly defined and easily identifiable damage indicators. A larger catalog of damage

indicators is needed along with estimates of the wind speed required to cause a certain degree of damage.

Recognizing the need to address these limitations, Texas Tech University (TTU) Wind Science and Engineering (WISE) Research Center personnel proposed a project to examine the limitations, revise or enhance the Fujita Scale and attempt to gain a consensus from the meteorological and engineering communities. A steering committee was first organized to initiate the project. Members of the Steering Committee are listed in Table 1. The next step was to organize a forum of users to identify the issues and develop strategies to improve or replace the Fujita Scale. The steering committee established the following objectives for the forum:

- Bring together a representative group of Fujita Scale users
- Identify key issues
- Make recommendations for a new or modified Fujita Scale
- Develop strategies for reaching a consensus from a broad cross section of users

Of the 26 users of the Fujita Scale invited, 23 attended the Fujita-Scale Forum, which was held in Grapevine, Texas, March 7-8, 2001. Forum participants are listed in Table 2. The group met for a day and a half and developed the following strategies for an Enhanced Fujita Scale:

- Identify additional damage indicators
- Correlate appearance of damage and wind speed
- Preserve the historical database
- Seek input from users

Damage Indicators and Degrees of Damage

NWS personnel at the forum expressed the need for additional damage indicators that could be used in rating the intensity of tornadoes. Based on their vast tornado damage investigation experience, the TTU project team proposed 28 damage indicators consisting of buildings, structures and trees. For each damage indicator (DI), several degrees of damage (DODs) are identified. The DODs are sequenced so each one requires a higher expected wind speed than the previous one. Damage ranges from the initiation of visible damage to complete destruction of the particular DI. A benefit of this approach is that, in the future, additional DIs can be added to the current list as new information becomes available.

Table 1. Steering Committee Members

Member	Title	Organization
Jim McDonald	Professor	Texas Tech University
Kishor Mehta	Director	Wind Science & Engineering Center
Don Burgess	Assistant Director	National Severe Storms Lab
Joe Schaefer	Director	Storm Prediction Center
Michael Riley	Engineer	National Institute of Standards and Technology
Brian Smith	Meteorologist	National Weather Service

Table 2. Fujita Scale Forum Participants

Forum Participant	Organization
Chuck Doswell	University of Oklahoma
Gregory Forbes	The Weather Channel
Joe Golden	Forecast Systems Laboratory
Tom Grazulis	Tornado Project
Rose Grant	State Farm Insurance
Quazi Hossain	Lawrence Livermore National Laboratory
Jeffery Kimball	U.S. Department of Energy
Tim Marshall	Haag Engineering
Daniel McCarthy	Storm Prediction Center
Brian Peters	National Weather Service
Erik Rasmussen	CIMMS, Boulder, CO
Tim Reinhold	Clemson University
Thomas Schmidlin	Kent State University
Lawrence Twisdale	Applied Research Associates
Larry Vennozzi	National Weather Service
Roger Wakimoto	UCLA
Josh Wurman	University of Oklahoma

The strategy of damage indicators requires that an expected, upper and lower bound wind speed be defined for each DOD. The range of wind speed defined by the upper and lower bound wind speeds accounts for circumstances that cause the actual wind speed associated with the damage to deviate from the expected value. The expected value of wind speed to cause a given DOD is based on a set of “normal” conditions: No glaring weak links, traditional construction quality, appropriate building materials, compliance with local building code and continuous maintenance. A weak link is a discontinuity in the load path, which runs from the building surface through the structural system to the foundation. Inadequate nailing of wood roof decking, marginal anchoring of roof structure to top of wall, discontinuity in the connection between first and second floor, use of cut nails instead of anchor bolts to attach sill plate to foundation are examples of load path discontinuities. Traditional construction quality means construction practices are considered acceptable in a majority of similar DIs in an area. Appropriate building materials are suitable for their specific use and for the environment of the area. Normal maintenance implies that the facility has not run down or deteriorated over time.

To obtain wind speeds associated with each DOD is a challenge. A deterministic approach involves structural analysis to determine component and structure resistance. Wind speeds to produce loads that overcome structural resistance are calculated. Monte Carlo simulation of tornado winds to produce damage to components or structure is another approach. Both of these approaches are time-consuming and expensive. The TTU project did not have sufficient resources available to carry out a full-blown study using either the deterministic or simulation approach.

An alternative approach has been successfully used to estimate seismic parameters that cannot be measured directly. The concept involves expert elicitation. In this case, a group of experts makes their best estimate of the expected, upper and lower bound wind speeds to cause each DOD. Since all experts will not predict the same wind speeds, the mean and standard deviation of the expected, upper and lower bound wind speeds are calculated. The means of the experts’ estimates are the expected wind speed and the range of values for a particular DOD. The group follows a well-defined protocol to arrive at the final estimates of wind speed.

Expert Elicitation Process

The elicitation protocol was established by the Senior Seismic Hazard Assessment Committee (SSHAC, 1997). A very specific procedure must be followed in order to achieve confidence in the results of the elicitation. The following steps constitute the process:

- Identify and describe the DIs and DODs in detail
- Identify and engage a panel of experts
- Discuss and refine the issues with the experts; provide all available data
- Train experts in the elicitation process
- Conduct individual elicitations and group interactions
- Analyze and aggregate elicitations and resolve issues
- Refine the wind speed estimates with several iterations
- Document and communicate the process and final results
- Obtain additional peer review of the process and results.

Six well-recognized experts were selected according to the SSHAC protocol. The expert's background included two meteorologists, two engineers, one architect and one individual with both a meteorological and engineering background. The engineers both have extensive wind damage investigation experience. One meteorologist worked with Dr. Fujita for a number of years; the other has extensive experience with damage investigations and Doppler radar research. The architect is a roofing expert with extensive roof damage documentation experience. The last expert uses his expertise in meteorology and engineering to assist insurance companies in understanding their wind damage losses. The experts are:

Greg Forbes – Meteorologist, the Weather Channel

Don Burgess – Meteorologist, National Severe Storms Laboratory

Doug Smith – Engineer, Wind Science and Engineering Center, TTU

Tim Reinhold – Engineer, Clemson University

Tom Smith – Architect, private consulting practice

Tim Marshall – Meteorologist/Engineer, Haag Engineers

The experts met for a day and a half to initiate the elicitation process. The DIs and DODs were defined. The experts were trained in the process and given all available data. They completed their first elicitation, which was their best estimate of the expected, upper and lower bound wind

speed, for each DOD, by the end of the first day. The results of Elicitation Round #1 were tabulated and presented to the experts the next morning. The results were discussed. They clarified the wording of some DODs. The meeting ended with instructions to the experts to refine their wind speed estimates based on discussions and comments on the first round elicitation. Again the results were tabulated by calculating mean and standard deviation of the estimated, upper and lower bound wind speeds. The DODs were arranged in order of increasing expected value of wind speed to cause the described damage. Results were distributed to experts again with instructions to make additional changes or adjustments to their values if needed. Very few changes were noted in the third round.

Proposed Damage Indicators and Degrees of Damage

For each DI the following information is provided:

- Name of DI
- Description of typical construction
- A series of DODs and the expected, lower and upper bound wind speed from the expert elicitation for each DI
- A plot of expected, lower and upper bound wind speeds for each DOD
- Photo of a typical DI (except for the most obvious ones)
- Photo illustrating specific DODs (when available)

The DIs are listed in Table 3. The DODs for a particular DI range from initiation of damage to total destruction of the building or structure. Each DI has several DODs, which describe damage in the range between initiation of damage and total destruction. A description of construction, a table of DODs and estimated wind speeds and a plot of DOD versus wind speed are provided on one page for each DI. These pages are contained in the Appendix A. As an example, Table 4 reproduces the data sheet for One and Two-Family Residences.

To understand how the process works, damage to a typical two-story residence is described here to illustrate how the degrees of damage are defined. The first DOD is initiation of damage. Visible damage generally initiates at the roof with loss of a small percentage (<20%) of roofing material. Windows and door glass begins to break from flying debris. This action is followed by removal of additional roofing material and uplift of part or all of the roof deck. Garage doors collapse inward or outward, depending on wind direction. Internal pressure

develops as a result of the broken windows or failed doors. Part of or all of the roof structure lifts up and is carried away by the winds. With removal of all or part of the roof structure, walls are no longer supported at the top. Exterior walls of the top floor collapse first, followed by the interior walls. As damage progresses, the second-floor floor structure is lifted up and removed. This leaves the first-floor walls unsupported. Again the exterior walls collapse first, followed by destruction of most first floor interior walls except possibly at small rooms, hallways or closets. The last degree of damage represents total devastation of the two-story residence. In a very intense tornado, this sequence of events takes place very rapidly. The roof and walls breakup creating flying debris that adds to the destruction. Note: DOD No. 5 is not

Table 3. Damage Indicators for EF Scale

DI No.	Damage Indicator (DI)
1	Small Barns or Farm Outbuildings (SBO)
2	One- or Two-Family Residences (FR12)
3	Manufactured Home – Single Wide (MHSW)
4	Manufactured Home – Double Wide (MHDW)
5	Apartments, Condos, Townhouses [3 stories or less] (ACT)
6	Motel (M)
7	Masonry Apartment or Motel Building (MAM)
8	Small Retail Building [Fast Food Restaurants] (SRB)
9	Small Professional Building [Doctor's Office, Branch Banks] (SPB)
10	Strip Mall (SM)
11	Large Shopping Mall (LSM)
12	Large, Isolated Retail Building [K-Mart, Wal-Mart] (LIRB)
13	Automobile Showroom (ASR)
14	Automobile Service Building (ASB)
15	Elementary School [Single Story; Interior or Exterior Hallways] (ES)
16	Junior or Senior High School (JHSH)
17	Low-Rise Building [1-4 Stories] (LRB)
18	Mid-Rise Building [5-20 Stories] (MRB)
19	High-Rise Building [More than 20 Stories] (HRB)
20	Institutional Building [Hospital, Government or University Building] (IB)
21	Metal Building System (MBS)
22	Service Station Canopy (SSC)
23	Warehouse Building [Tilt-up Walls or Heavy-Timber Construction](WHB)
24	Electrical Transmission Lines (ETL)
25	Free-Standing Towers (FST)
26	Free-Standing Light Poles, Luminary Poles, Flag Poles (FSP)
27	Trees: Hardwood (TH)
28	Trees: Softwood (TS)

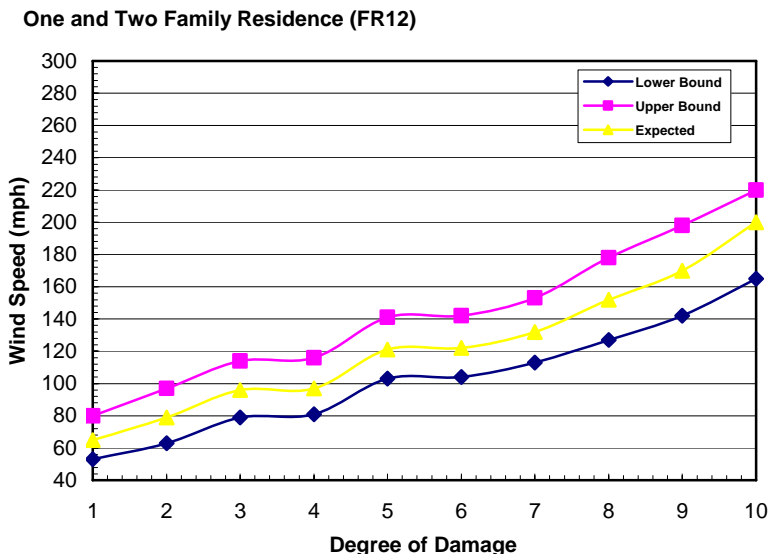
Table 4. One- and Two-Family Residences (FR12)

Typical Construction

- Asphalt shingles, tile, slate or metal roof covering
- Flat, gable, hip, mansard or mono-sloped roof or combinations thereof
- Plywood/OSB or wood plank roof deck
- Prefabricated wood trusses or wood joist and rafter construction
- Brick veneer, wood panels, stucco, EIFS, vinyl or metal siding
- Wood or metal stud walls, concrete blocks or insulating-concrete panels
- Attached single or double garage

DOD*	Damage description	Exp**	LB	UB
1	Threshold of visible damage	65	53	80
2	Loss of roof covering material (<20%), gutters and/or awning; loss of vinyl or metal siding	79	63	97
3	Broken glass in doors and windows	96	79	114
4	Uplift of roof deck and loss of significant roof covering material (>20%); collapse of chimney; garage doors collapse inward or outward; failure of porch or carport	97	81	116
5	Entire house shifts off foundation	121	103	141
6	Large sections of roof structure removed; most walls remain standing	122	104	142
7	Exterior walls collapsed	132	113	153
8	Most walls collapsed in bottom floor, except small interior rooms	152	127	178
9	All walls collapsed	170	142	198
10	Destruction of engineered and/or well constructed residence: slab swept clean	200	165	220

* DOD is degree of damage **Wind Speed values are in mph



part of the sequence described above. Occasionally an entire house will shift off its foundation when not securely anchored to the foundation. The house is simply sitting on the foundation with no anchors. After shifting off the foundation, additional damage may occur.

The DODs for each DI are arranged in a sequence of increasing degrees of damage. Thus, if only the roof structure of the two-story residence is uplifted by a storm and the exterior walls remain in place (DOD 6), the expected wind speed of the storm at that location is estimated to be 122 mph. The reported value could vary from 104 to 142 mph depending on circumstances. Large overhangs (greater than 2 ft), improper toe nailing (two nails instead of three) or rotted wood at roof-to-wall connection would suggest a wind speed less than 122 mph but not less than 104 mph.. Use of hurricane clips or other positive anchorage devices suggest a wind speed higher than 122 mph but not greater than 142 mph.. The EF-Scale rating would be the category containing the estimated wind speed for this degree of damage.

Correlation of Fujita Scale and EF Scale

Members of the Fujita-Scale Forum insisted that the historical tornado database be preserved. Thus, there is a need to derive a relationship between the Fujita Scale and the EF Scale. The first step in the process is to obtain a correlation based on wind speed. In order to obtain a correlation between Fujita-Scale and EF-Scale wind speeds, the help of a second set of experts was needed. They used the original Fujita Scale criteria to assign Fujita-Scale categories(i.e. F0, F1, etc) to the DOD's of the new EF Scale. A regression analysis was performed to obtain a relationship between the Fujita-Scale and EF-Scale wind speeds. The steps of the process are described in this section.

The second expert group was selected for their experiences with damage investigation and application of the Fujita Scale. The following experts participated:

Bill Bunting – NWSFO – Fort Worth, Texas

Brian Peters – NWSFO – Calera, Alabama

John Ogren – NWSFO – Indianapolis, Indiana

Dennis Hull – NWSFO – Pendleton, Oregon

Tom Matheson – NWSFO – Wilmington, North Carolina

Brian Smith – NWSFO – Valley, Nebraska

The exercise was conducted by mail without a formal meeting of the group. The purpose and procedure of the exercise were described in an accompanying letter. Since we were interested in knowing how these experts would rate the DI's and DOD's based on the original Fujita Scale, only one iteration was solicited. They were simply asked to apply a Fujita-Scale rating to the damage description of each DOD for all 28 DI's. The Fujita-Scale ratings were then expressed in terms of the median value of each Fujita-Scale wind speed range. The Fujita-Scale wind speeds were then converted to a 3-second gust frame of reference. The average, estimated Fujita-Scale wind speed of the six experts was then compared with the expected value wind speed from the expert elicitation process for each DOD. A regression analysis was then performed to obtain a correlation between the mean Fujita-Scale wind speed and the EF-Scale expected wind speed for each DOD. Figure 1 is a plot of the points used in the regression analysis. A linear regression function fit the data very well.

$$y = 0.6246x + 36.393 \quad (1)$$

where y is the EF-Scale wind speed and x is the Fujita-Scale wind speed (both are 3-second gust in mph).

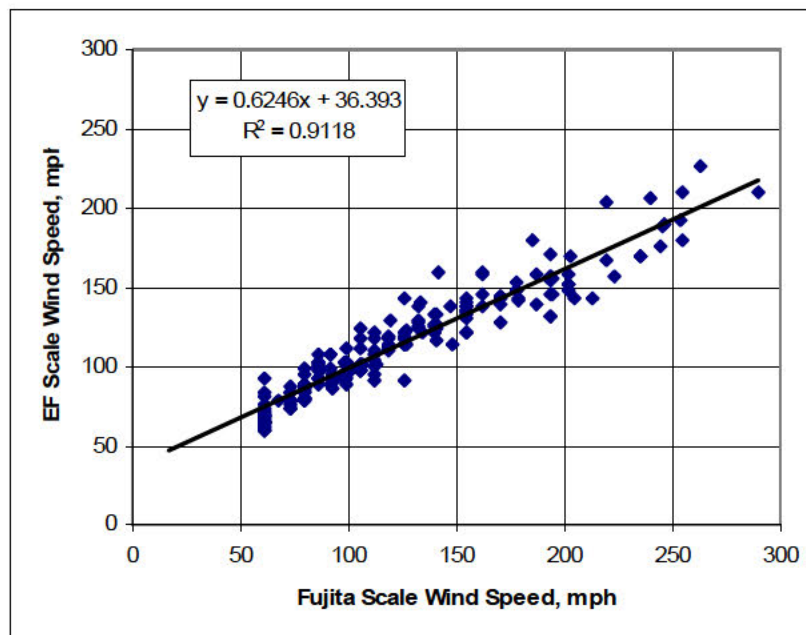


Figure 1. Correlation of Fujita-Scale and EF-Scale Wind Speeds

The correlation coefficient is

$$R^2 = 0.91 \quad (2)$$

which represents a very good fit of the data.

Proposed EF Scale

The basic wind speed ranges of the proposed EF-Scale are derived from the original Fujita Scale ranges by using Equation 1. The original Fujita-Scale wind speeds are first converted from fastest one-quarter mile to 3-second gust speeds using the Durst curve (Durst, 1960). They are then substituted into Equation 1 to obtain the wind speed ranges of the EF Scale. Table 5 shows the results of these calculations. The recommended EF-Scale wind speeds are shown in Table 6. Values have been rounded to avoid implying more accuracy than justified.

Table 5. EF-Scale Wind Speed Ranges Derived from Fujita-Scale Wind Speed Ranges

Fujita Scale			EF Scale	
Fujita Scale	Fastest 1/4-mile Wind Speeds, mph	3-Second Gust Speed, mph	EF Scale	3-Second Gust Speed, mph
F0	40 - 72	45 - 78	EF0	65 - 85
F1	73 - 112	79 - 117	EF1	86 - 109
F2	113 - 157	118 - 161	EF2	110 - 137
F3	158 - 207	162 - 209	EF3	138 - 167
F4	208 - 260	210 - 261	EF4	168 - 199
F5	261 - 318	262 - 317	EF5	200 - 234

Table 6. Recommended EF-Scale Wind Speed Ranges

Derived EF Scale		Recommended EF Scale
EF Classes	3-Second Gust Speed, mph	3-Second Gust Speed, mph
EF0	65 - 85	65 - 85
EF1	86 - 109	86 - 110
EF2	110 - 137	111 - 135
EF3	138 - 167	136 - 165
EF4	168 - 199	166 - 200
EF5	200 - 234	>200

By correlating the Fujita-Scale wind speeds with the EF-Scale wind speeds, a tornado rated according to the Fujita Scale will have the same “F-Number” in the EF Scale, e.g. F3 translates into EF3, although the wind speed ranges are different (see Table 5).

The recommended EF5 category has no stated upper bound. An absolute upper bound on tornado wind speed has not been defined to date. Having no stated upper bound for EF5 will prevent the news media from always assuming the worst case scenario.

EF-Scale Protocol

The EF-Scale is intended for application to an individual building, structure or other damage indicator. It is also designed to obtain a rating for a tornado event. Members of the Forum were very specific in their opinion that a single building, structure or other DI should not be used to rate a tornado event. Several DIs should be considered in assigning an EF-Scale rating to a tornado event, if available.

Rating an Individual Building or Structure

An EF-Scale rating is obtained for an individual building or structure by the following sequence of actions. A DI is chosen from the list of the DIs in Table 3. The construction description should reasonably match the building or structure being considered and the observed damage should reasonably match one of the DODs.

Under normal circumstances, the expected value is representative of the observed damage. However, there are factors or conditions that can cause a deviation (either lower or higher) from the expected wind speed for a DOD. The evaluator makes a judgment within the range of upper and lower bound wind speeds as to whether the wind speed to cause the damage is higher or lower than the stated expected. The EF-Scale rating is the one with a range of wind speed that contains the estimated wind speed to produce the DOD. The EF-Scale rating as described above applies only to that particular indicator. Additional DIs should be considered in assigning an EF-Scale rating to a tornado event.

Rating a Tornado Event

The rating of a tornado event should represent an estimate of the highest wind speed that occurred during the life cycle of the tornado. It is well known that wind speed intensity varies

both along the length and across the width of a tornado damage path. It may not be possible to estimate the true tornado wind speed, if the actual wind speed is greater than the upper bound wind speed of the DI being considered. For example, the upper bound wind speed for total destruction of a one and two-family residence is 220 mph. The actual wind speed in the tornado could have been higher since there is not another DOD to indicate a higher wind speed.

Ideally the recommended approach for assigning an EF-Scale rating to a tornado event involves the following steps:

- Conduct an aerial survey of damage path to identify possible damage indicators and define the extent of the damage path
- Select several DIs that tend to indicate the highest wind speed within the damage path
- Locate those DIs within the damage path
- Conduct a ground survey and carefully examine the DIs of interest
- Follow the steps outlined for assigning EF-Scale rating to individual DIs and document the results
- Consider the estimated wind speeds of several DIs, if available, and arrive at an EF-Scale rating for the tornado event
- Rate the tornado intensity by applying the highest rated DI, provided there is supporting evidence of similar damage intensity immediately surrounding the DI.
- Record the basis for assigning an EF-Scale rating to the tornado event
- Record other pertinent data relating to the tornado event.

Conclusion

An Enhanced Fujita Scale (EF Scale) is proposed in this document. The enhanced scale addresses the major limitations of the original Fujita Scale that was first published in 1971. Additional damage indicators (DIs) are proposed along with degrees of damage (DODs). Through an expert elicitation process, wind speeds corresponding to the described damage for each DOD are estimated. The estimated wind speed then determines the EF-Scale category appropriate for the observed damage. The categories range from EF0 to EF5. The wind speed ranges in each category are related to Fujita Scale ranges by a correlation function (Equation 1). This correlation between Fujita-Scale and EF-Scale wind speeds provides a link between the two

scales and thus makes it possible to express a Fujita-Scale rating in terms of an EF-Scale rating. The only difference is the wind speed ranges in each scale. Thus, the historical tornado database is preserved and can be easily converted to the criteria of the EF Scale.

The problem of no DIs in open country remains. Research is currently underway to identify additional damage indicators and to obtain estimates of the wind speeds to cause defined damage. Of particular interest are damage to various crops, farm equipment, silos, grain storage facilities and irrigation equipment. These indicators can be incorporated as DIs in the EF Scale as reliable data become available. The technology of portable Doppler radar should also be a part of the EF Scale process, either as a direct measurement, when available, or as a means of validating the wind speeds estimated by the experts.

The authors recommend that the EF Scale be given serious consideration for ultimately replacing the Fujita Scale as a means of rating the intensity of tornadoes. Additional refinements will be possible as experience is gained from use of the EF Scale.

References

- Durst, C.S., 1960: Wind speeds over short periods of time, *Meteorological Magazine*, Vol. 89, London, England, 6 pp.
- Fujita, T.T., 1971: Proposed characterization of tornadoes and hurricanes by area and intensity. Satellite and Mesometeorology Research Project Report 91, the University of Chicago, 42 pp.
- Marshall, T.P., 2003: The La Plata, MD tornado: Issues regarding the F-Scale. *Preprints*, Fujita Symposium on the Fujita Scale and Severe Weather Damage Assessment, Long Beach, CA, American Meteorology Society.
- McDonald, J.R. and K.C. Mehta, 2001: Summary report of the Fujita Scale forum. Wind Science and Engineering, Texas Tech University, Lubbock, TX, 36 pp.
- Minor, J.E., J.R. McDonald, and K.C. Mehta, 1977: The tornado: An engineering oriented perspective. NOAA Technical Memorandum, ERL NSSL-82, National Severe Storms Laboratory, Norman, OK, 103 pp.
- Phan, L.T. and E. Simiu, 1998: The Fujita tornado intensity scale: a critique based on observations of the Jarrell tornado of May 27, 1997. NIST Tech. Note 1426, U.S. Department of Commerce, Gaithersburg, MD, 20 pp.
- SSHAC, 1997: Recommendations for probabilistic seismic hazard analysis: guidelines on uncertainty and use of experts, NUREG/CR6372, UCRL-ID-122160, Vol. I, Lawrence Livermore National Laboratory, Livermore, CA, 131 pp.

Acknowledgments

The Authors wish to acknowledge the contributions of the steering committee, the persons who attended the Fujita-Scale forum and the twelve experts who participated in the two elicitation processes. Each one made a valuable contribution to the project. Special thanks go to Greg Forbes and Don Burgess for their encouragement and input to the project. The help of Sundar Mani, a WISE graduate student at Texas Tech, is also acknowledged. The work was performed under the U.S. Department of Commerce, National Institute of Standards and Technology(NIST)/Texas Tech University Cooperative Agreement Award 70NANB8H0059.

APPENDIXES

- A. Twenty-eight Damage Indicators with Photos
- B. Expert Elicitation of Damage versus Wind Speed
- C. Fujita Scale Ratings of DODs by NWS Panel

Appendix A

TWENTY-EIGHT DAMAGE INDICATORS WITH PHOTOS

NO.	DAMAGE INDICATORS (DI)
1	Small Barns or Farm Outbuildings (SBO)
2	One- or Two-Family Residences (FR12)
3	Manufactured Home – Single Wide (MHSW)
4	Manufactured Home – Double Wide (MHDW)
5	Apartments, Condos, Townhouses (ACT)
6	Motel (M)
7	Masonry Apartment or Motel (MAM)
8	Small Retail Building (SRB)
9	Small Professional Building (SPB)
10	Strip Mall (SM)
11	Large Shopping Mall (LSM)
12	Large, Isolated Retail Building (LIRB)
13	Automobile Showroom (ASR)
14	Automobile Service Building (ASB)
15	Elementary School (ES)
16	Junior or Senior High School (JHSH)
17	Low-Rise Building [1-4 Stories] (LRB)
18	Mid-Rise Building [5-20 Stories] (MRB)
19	High-Rise Building [More than 20 Stories] (HRB)
20	Institutional Building (IB)
21	Metal Building System (MBS)
22	Service Station Canopy (SSC)
23	Warehouse Building (WHB)
24	Electrical Transmission Lines (ETL)
25	Free-Standing Towers (FST)
26	Free-Standing Light Poles, Luminary Poles, Flag Poles (FSP)
27	Trees: Hardwood (TH)
28	Trees: Softwood (TS)

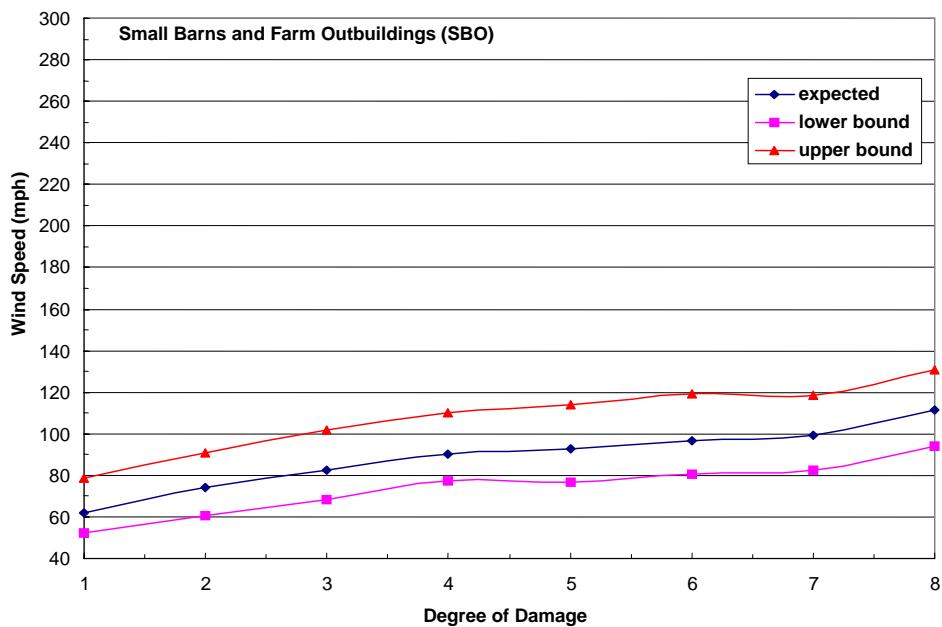
1. SMALL BARN AND FARM OUTBUILDINGS (SBO)

Typical Construction

- Less than 2500 sq ft
- Wood or metal post and beam construction
- Wood or metal roof trusses
- Wood or metal panel siding
- Metal or wood roof
- Large doors

DOD*	Damage description	EXP	LB	UB
1	Threshold of visible damage	62	53	78
2	Loss of wood or metal roof panels	74	61	91
3	Collapse of doors	83	68	102
4	Major loss of roof panels	90	78	110
5	Uplift or collapse of roof structure	93	77	114
6	Collapse of walls	97	81	119
7	Overturning or sliding of entire structure	99	83	118
8	Total destruction of building	112	94	131

* Degree of damage



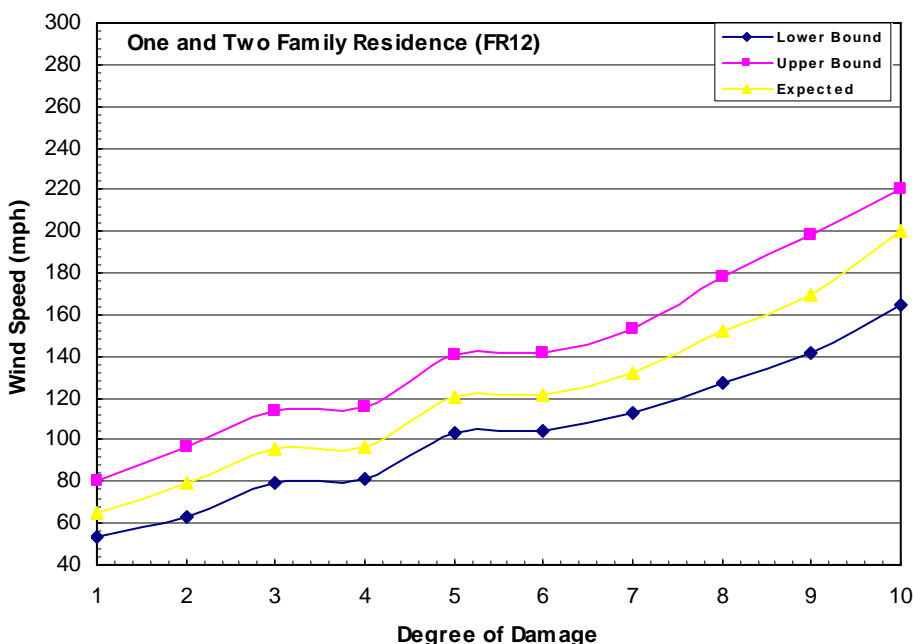
2. ONE-AND TWO-FAMILY RESIDENCES (FR12)
(1000 – 5000 sq. ft.)

Typical Construction

- Asphalt shingles, tile, slate or metal roof covering
- Flat, gable, hip, mansard or mono-sloped roof or combinations thereof
- Plywood/OSB or wood plank roof deck
- Prefabricated wood trusses or wood joist and rafter construction
- Brick veneer, wood panels, stucco, EIFS, vinyl or metal siding
- Wood or metal stud walls, concrete blocks or insulating-concrete panels
- Attached single or double garage

DOD*	Damage description	EXP	LB	UB
1	Threshold of visible damage	65	53	80
2	Loss of roof covering material (<20%), gutters and/or awning; loss of vinyl or metal siding	79	63	97
3	Broken glass in doors and windows	96	79	114
4	Uplift of roof deck and loss of significant roof covering material (>20%); collapse of chimney; garage doors collapse inward; failure of porch or carport	97	81	116
5	Entire house shifts off foundation	121	103	141
6	Large sections of roof structure removed; most walls remain standing	122	104	142
7	Exterior walls collapsed	132	113	153
8	Most walls collapsed, except small interior rooms	152	127	178
9	All walls	170	142	198
10	Destruction of engineered and/or well constructed residence; slab swept clean	200	165	220

* DOD is degree of damage



2. ONE-AND TWO-FAMILY RESIDENCE (FR12)



FR12: DOD 2: Loss of roof covering (<20%)



FR12: DOD 4: Uplift of roof deck and loss of roof covering (>20%); garage door collapses outward



FR12: DOD 6: Large sections of roof removed; most walls remain standing



FR12: DOD 7: Top floor (First floor in this case) exterior walls collapsed



FR12: DOD 10: Total destruction of entire building

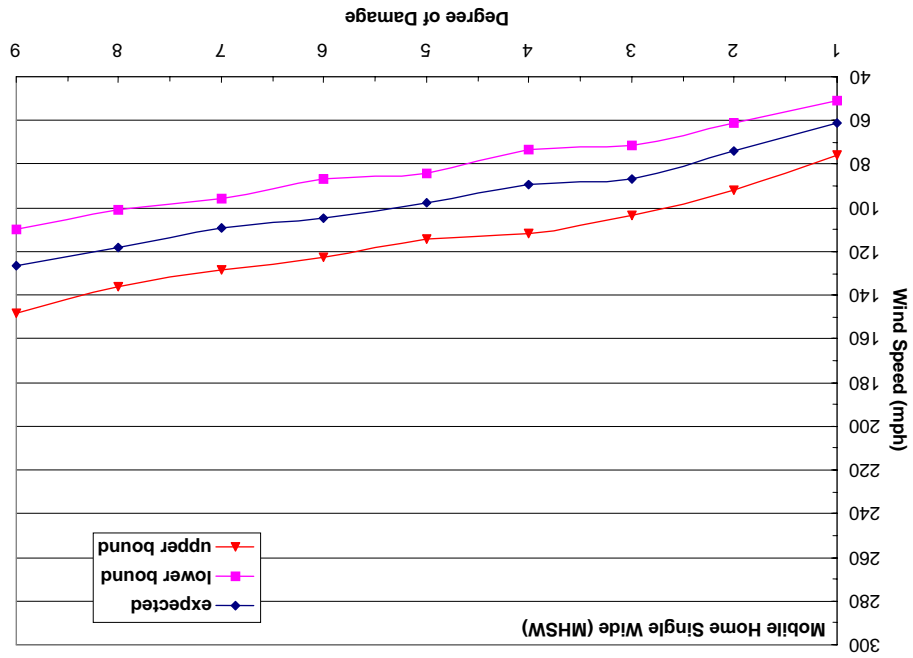
3. MANUFACTURED HOMES – SINGLE WIDE (MHSW)

Typical Construction

- Steel undercarriage supported on concrete block piers
- Metal straps and ground anchors (Frame and/or over-the-top strap anchors)
- Asphalt shingles or one-piece metal roof covering
- Wood roof joists
- Metal, vinyl or wood siding
- Wood stud walls and partitions
- Better construction in post 1974 models in coastal areas

DOD*	Damage description	EXP	LB	UB
1	Threshold of visible damage	61	51	76
2	Loss of shingles or partial uplift of one-piece metal roof covering	74	61	92
3	Unit slides off block piers but remains upright	87	72	103
4	Complete uplift of roof; most walls remain standing	89	73	112
5	Unit rolls on its side or upside down; remains essentially intact	98	84	114
6	Destruction of roof and walls leaving floor and undercarriage in place	105	87	123
7	Unit rolls or vaults; roof and walls separate from floor and undercarriage	109	96	128
8	Undercarriage separates from unit; rolls, tumbles and is badly bent	118	101	136
9	Complete destruction of unit; debris blown away	127	110	148

DOD is degree of damage



3. MANUFACTURED HOMES – SINGLE WIDE (MHSW)



MHSW: DOD 3: Unit slides off block piers but remains upright



MHSW: DOD 4: Complete uplift of roof; most walls remain standing



MHSW: DOD 6: Destruction of roof and walls leaving floor and undercarriage in place



MHSW: DOD 9: Complete destruction of unit; debris blown away

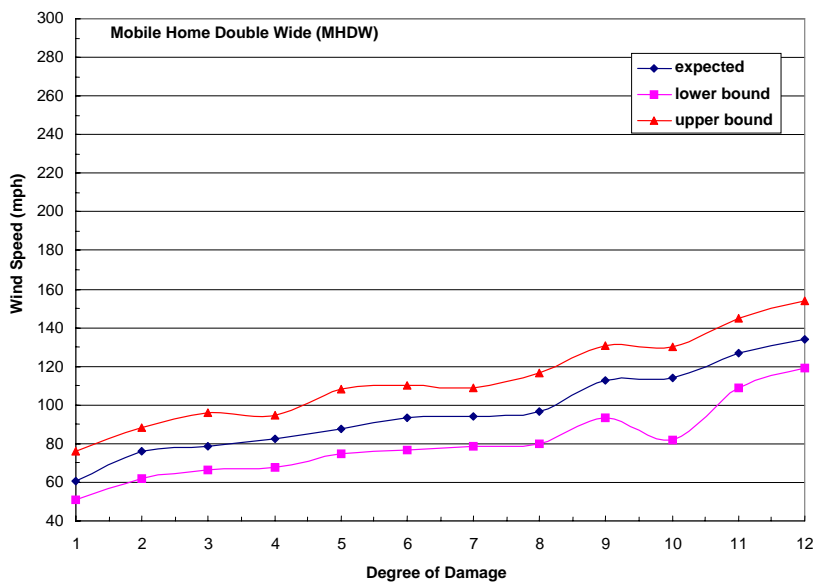
4. MANUFACTURED HOME – DOUBLE WIDE (MHDW)

Typical Construction

- Steel undercarriage supported on concrete block piers
- Multi-unit connection at roof, floor and end walls
- Frame straps and ground anchors spaced at 10 – 12 ft apart
- Flat, gable or hip roof shape
- Asphalt shingles or metal roof panels
- Plywood/OSB roof decking
- Wood rafter or shallow joist construction
- Metal, vinyl or wood siding

DOD*	Damage description	EXP	LB	UB
1	Threshold of visible damage	61	51	76
2	Loss of shingles or other roof covering (<20%)	76	62	88
3	Damaged porches or carports	78	67	96
4	Broken windows	83	68	95
5	Uplift of roof deck and loss of significant roof covering material (>20%)	88	75	108
6	Complete uplift of roof; most walls remain standing	93	77	110
7	Unit slides off CMU block piers	94	78	109
8	Removal of entire roof structure leaving most walls standing	97	80	117
9	Complete destruction of roof and walls leaving undercarriage in place	113	93	131
10	Unit rolls, displaces or vaults	114	82	130
11	Undercarriage separates from floor, rolls and tumbles, badly bent	127	109	145
12	Complete destruction of unit; debris blows away	134	119	154

* DOD is degree of damage



MANUFACTURED HOME – DOUBLE WIDE (MHDW)



MHDW: DOD 5: Uplift Of roof deck and loss of significant roof covering material (>20%)



MHDW: DOD 11: Undercarriage separates from floor; rolls and tumbles, badly bent

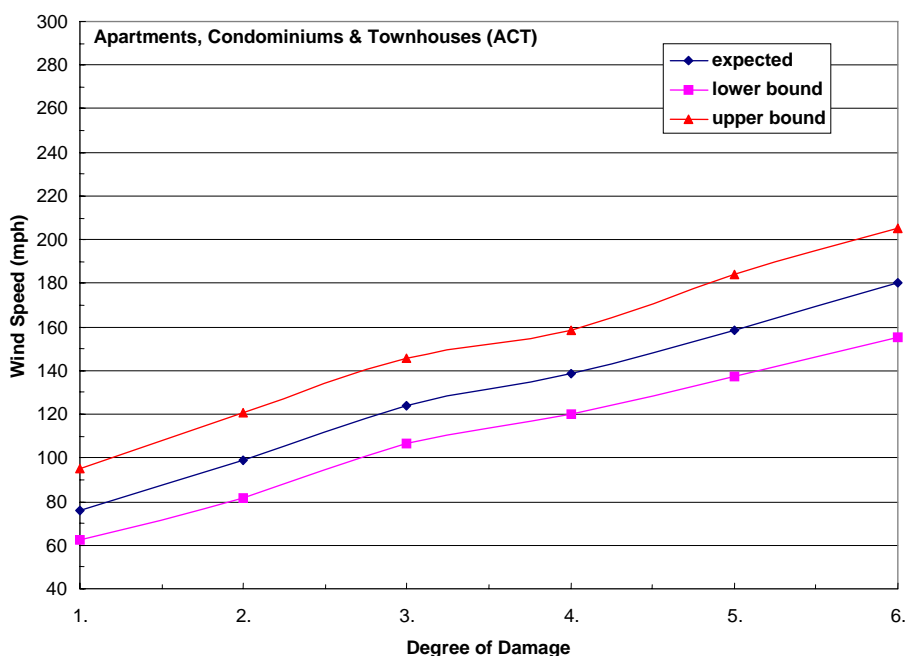
5. APARTMENTS, CONDOMINIUMS AND TOWNHOUSES (ACT) (Three stories or less)

Typical Construction

- Flat, gable, hip or mansard roof
- Asphalt shingles, tile, metal or BUR roof covering
- Plywood/OSB roof decking
- Light-framed wood or metal roof trusses
- Wood, metal or vinyl panels, stucco brick veneer or EIFS wall covering; combinations of wall coverings
- Wood or metal stud walls
- Wood floor diaphragms
- Sliding patio doors; balconies

DOD*	Damage description	EXP	LB	UB
1	Threshold of visible damage	76	63	95
2	Loss of roof covering (<20%)	99	82	121
3	Uplift of roof decking; significant loss of roof covering (>20%)	124	107	146
4	Uplift or collapse of roof structure leaving most walls standing	138	120	158
5	Most top story walls collapsed	158	138	184
6	Almost total destruction of top two stories	180	155	205

* DOD is degree of damage



5. APARTMENTS, CONDOMINIUMS AND TOWNHOUSES (ACT)



ACT: Gable roof, asphalt shingles, wood decking, light-framed, wood construction, brick veneer, wood stud walls, balconies



ACT: DOD 2: Loss of roof covering (<20%)



ACT: DOD 4: Uplift or collapse of roof structure leaving most walls standing



ACT: DOD 5: Most top story walls collapsed

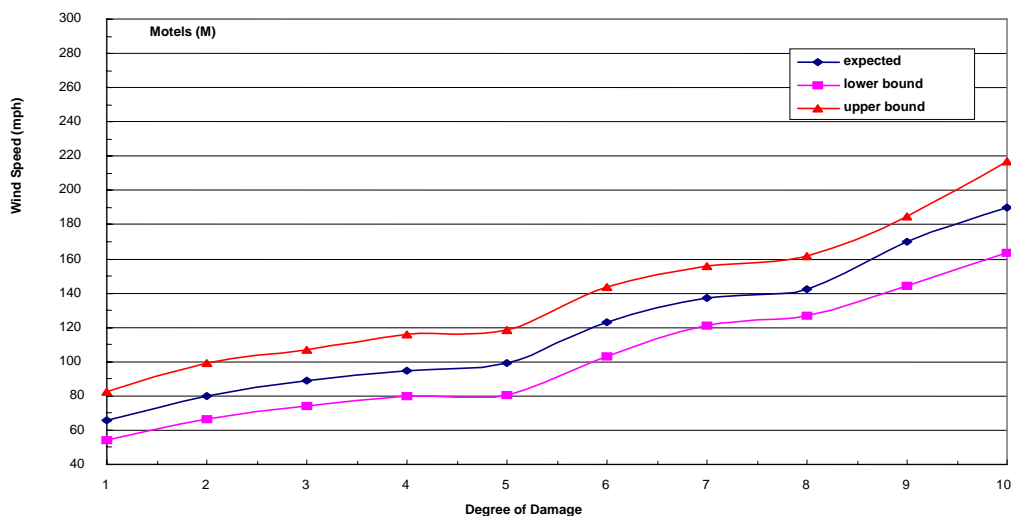
6. MOTELS (M)

Typical Construction

- Less than or equal to four stories
- Facility made up of one or more multi-story, rectangular buildings
- Flat, gable, hip or mansard roof
- Asphalt shingles, tile, slate or BUR roof covering
- Plywood/OSB roof decking
- Wood or metal prefabricated roof trusses
- Wood floor diaphragms
- Wood or metal stud walls
- Stucco, EIFS, wood, metal or brick veneer wall cladding
- Canopy over driveway at entrance
- Exterior walkways or balconies

DOD*	Damage description	EXP	LB	UB
1	Threshold of visible damage	66	54	83
2	Loss of roof covering (<20%)	80	67	99
3	Broken windows or patio doors	89	74	107
4	Uplift of roof decking; significant loss of roof covering (>20%); loss of EIFS wall cladding	95	80	116
5	Uplift or collapse of canopy over driveway	99	81	118
6	Uplift or collapse of roof structure leaving most walls standing	123	103	143
7	Collapse of top story exterior walls	138	121	156
8	Collapse of most top story walls	143	127	162
9	Collapse of top two floors of three or more stories	170	144	185
10	Total destruction of entire building	190	163	217

* DOD is degree of damage



6. MOTELS



M: Less than five stories; one or more rectangular modules; flat, gable, hip or mansard roof; asphalt shingles, tile, slate or BUR covering; plywood or metal roof decking; stud walls with EIFS, stucco or wood siding or brick veneer; canopy over driveway at entrance; exterior walkways or balconies

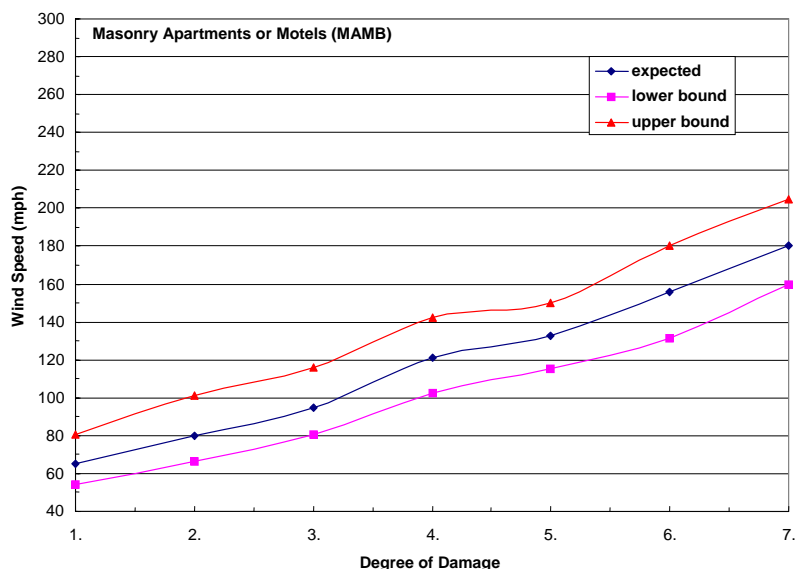
7. MASONRY APARTMENTS OR MOTELS (MAM)

Typical Construction

- Less than or equal to four stories
- Facility made up of one or more multi-story, rectangular buildings
- Flat, gable, hip or mansard roof
- Asphalt shingles, tile, slate or BUR roof
- Light steel roof framing with metal deck and lightweight insulation
- Pre-cast or hollow-core concrete roof and floor system
- CMU non-bearing walls
- CMU load-bearing walls
- Stucco, EIFS, or brick veneer wall cladding
- Exterior walkways or balconies

DOD*	Damage description	EXP	LB	UB
1	Threshold of visible damage	65	54	81
2	Loss of roof covering (<20%)	80	67	101
3	Uplift of lightweight metal roof decking	95	81	116
4	Uplift of concrete roof decking	121	103	143
5	Collapse of top story walls	133	115	150
6	Collapse of top two floors of three or more stories	156	132	180
7	Total destruction of a large section of building	180	160	205

* DOD is degree of damage



7. MASONRY APARTMENTS OR MOTEL (MAM)



MAM: Four stories, rectangular plan, mansard roof, pre-cast, hollow-core roof & floor system, CMU load-bearing walls, EIFS exterior walls



MAM: DOD 5: Collapse of top story walls



MAM: DOD 5: Collapse of top story walls

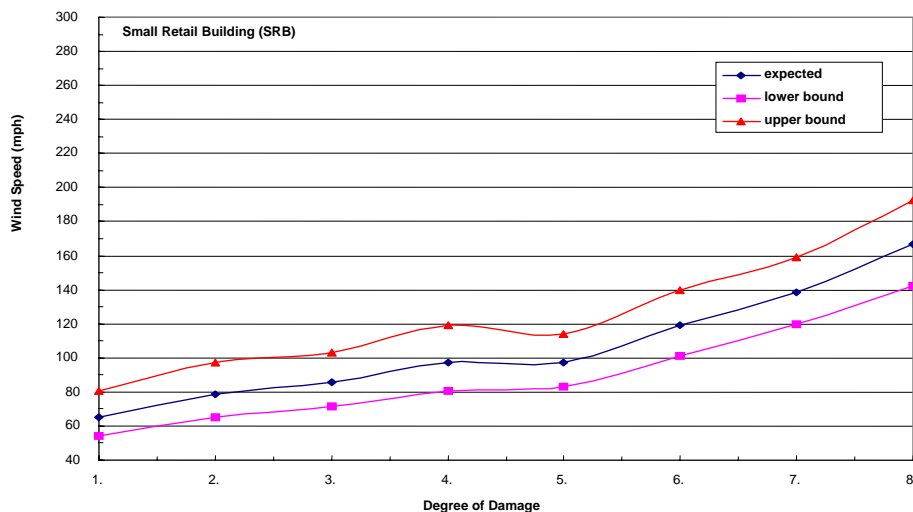
8. SMALL RETAIL BUILDING (SRB)

Typical Construction

- Best example is fast-food restaurant
- Flat, hip, gable, mansard or monoslope roof
- Asphalt shingles, metal panels, slate, tile, single-ply or BUR roof covering
- Plywood/OSB roof decking
- Wood or metal roof structure consisting of trusses or rafters and joists
- Wood or metal stud walls
- Typically have large areas of window glass and double entry doors
- Canopies, covered walkways or porches
- Wood, brick veneer, metal or vinyl siding, concrete blocks, EIFS or stucco wall cladding

DOD*	Damage description	EXP	LB	UB
1	Threshold of visible damage	65	54	81
2	Loss of roof covering (<20%)	78	65	98
3	Broken glass in windows and doors	86	72	103
4	Uplift of roof decking; significant loss of roof covering (>20%)	98	81	119
5	Canopies or covered walkways destroyed	98	83	114
6	Uplift or collapse of entire roof structure	119	101	140
7	Collapse of exterior walls; closely spaced interior walls remain standing	138	120	159
8	Total destruction of entire building	167	143	193

* DOD is degree of damage



8. SMALL RETAIL BUILDING (SRB)



SRP: Hip roof, metal panel roof, wood trusses and stud walls, metal or vinyl siding



SRP: DOD 3: Broken glass in windows and doors



SRB: DOD 5: Canopies and covered walkways destroyed

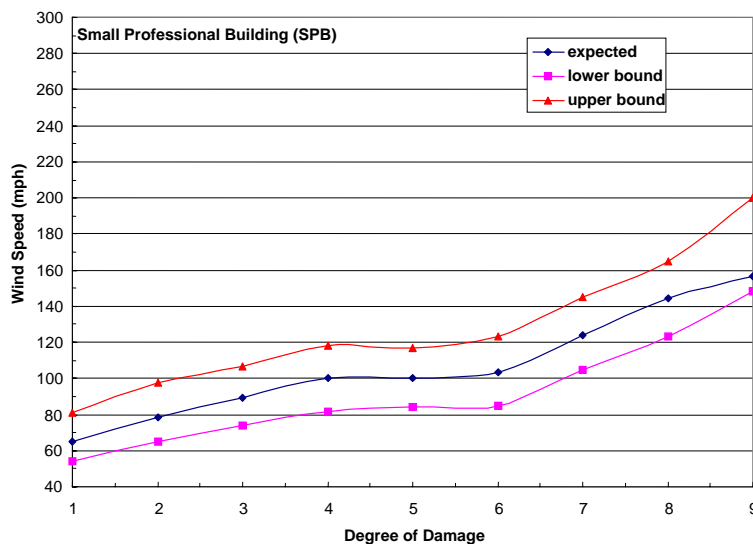
9. SMALL PROFESSIONAL BUILDING (SPB)
(Single story, less than 5000 ft²)

Typical Construction

- Flat, gable, hip, mansard or mono-slope roofs with or without parapet walls
- Asphalt shingles, tile, slate, metal panels, single-ply or built-up roof covering
- Light-frame steel construction, steel joists and formed metal decking
- Load-bearing masonry construction with steel or wood roof structure
- Timber post and beam construction
- Wood or metal stud walls, non-bearing masonry walls
- Metal or vinyl panels, stucco or EIFS cladding
- Skylights and/or clearstories

DOD*	Damage description	EXP	LB	UB
1	Threshold of visible damage	65	54	81
2	Loss of roof covering (<20%)	78	65	98
3	Broken windows, including clear story windows or skylights	89	74	107
4	Exterior doors fail	100	82	118
5	Uplift of roof decking; significant loss of roof covering (>20%); loss of rooftop HVAC equipment	100	84	117
6	Collapsed façade or parapet walls	103	85	123
7	Uplift or collapse of entire roof structure	124	105	145
8	Collapse of exterior walls; closely spaced interior walls remain standing	144	123	165
9	Total destruction of entire building	157	148	200

* DOD is degree of damage



9. SMALL PROFESSIONAL BUILDING (SPB)



SPB: Hip roof, metal panel roofing, Light-frame steel construction,
metal stud walls, brick veneer

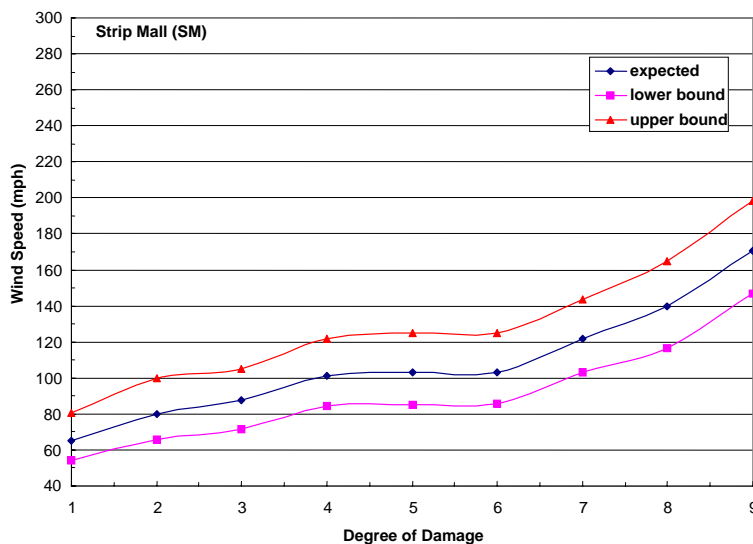
10. STRIP MALL (SM)

Typical Construction

- Large, rectangular single-story building with large surrounding parking lots
- Flat roof with parapet wall
- Built-up roofing or single-ply roof membrane with rigid insulation
- Wood or metal deck, wood-fiber cement panels
- Light-frame steel roof support with steel joists or joist girders
- Brick or concrete block wall construction
- Large window glass and glass entry doors
- Covered walkway attached to building

DOD*	Damage description	EXP	LB	UB
1	Threshold of visible damage	65	54	81
2	Uplift of roof covering at eaves and roof corners	80	66	100
3	Broken windows or glass doors	88	72	105
4	Uplift of roof decking	101	84	122
5	Collapsed façade or parapet walls	103	85	125
6	Covered walkways uplifted or collapsed	103	86	125
7	Uplift or collapse of entire roof structure	122	103	143
8	Collapse of exterior walls; closely spaced interior walls remain standing	140	117	165
9	Complete destruction of all or a large section of building	171	147	198

* DOD is degree of damage



10. STRIP MALL (SM)



SM: Long, rectangular, single-story building; flat roof with parapet ; BUR or single-ply membrane roof system with rigid insulation; wood, metal or wood-fiber cement roof panels; concrete block walls or stud walls with brick veneer; large glass windows and glass entry doors; canopy or covered walkway attached to building

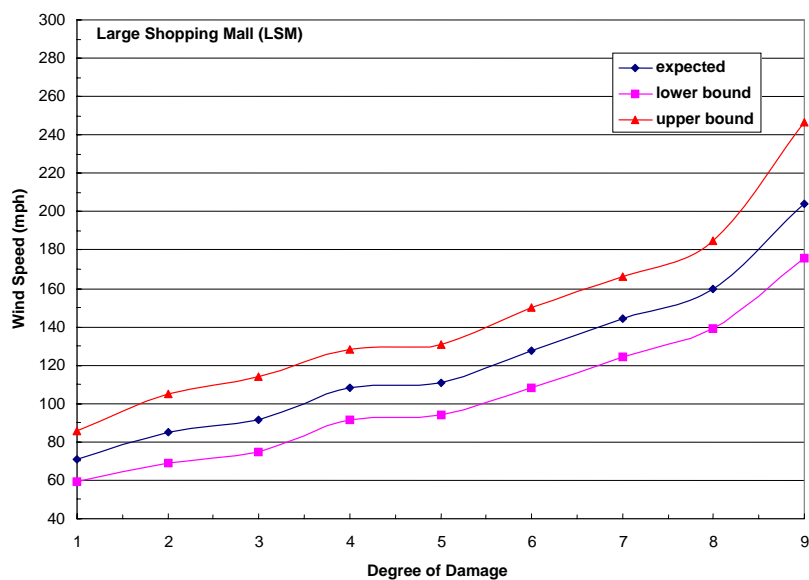
11. LARGE SHOPPING MALL (LSM)

Typical Construction

- Typically one or two stories
- Flat roof; some areas with relatively large spans
- Skylights and clear stories
- Single-ply or BUR with or without roof gravel
- Metal stud walls with brick veneer, stucco or EIFS cladding
- Light steel structural framing with open web joists, light metal framing or 3-D space framing
- Glass at entries

DOD*	Damage description	EXP	LB	UB
1	Threshold of visible damage	71	59	86
2	Loss of roof covering (<20%)	85	69	105
3	Broken skylights, clearstory windows and atrium walls broken	92	75	114
4	Uplift of some roof decking; significant loss of roofing material (>20%); loss of rooftop HVAC	108	92	128
5	Wall cladding stripped starting at corners and progressing to other areas	111	94	131
6	Roof structure uplifted or collapsed	128	108	150
7	Exterior walls in top story collapsed	144	124	166
8	Interior walls of top story collapse	160	139	185
9	Complete destruction of all or a large section of the building	204	176	247

* DOD is degree of damage



11. LARGE SHOPPING MALL



LSM: One or two stories, flat roof with some large spans, skylights, built-up roof with gravel, metal stud walls with brick veneer, light steel structural framing, glass entries



LSM: DOD 4: Uplift of some roof decking; significant loss of roofing material (>20%); loss of rooftop HVAC

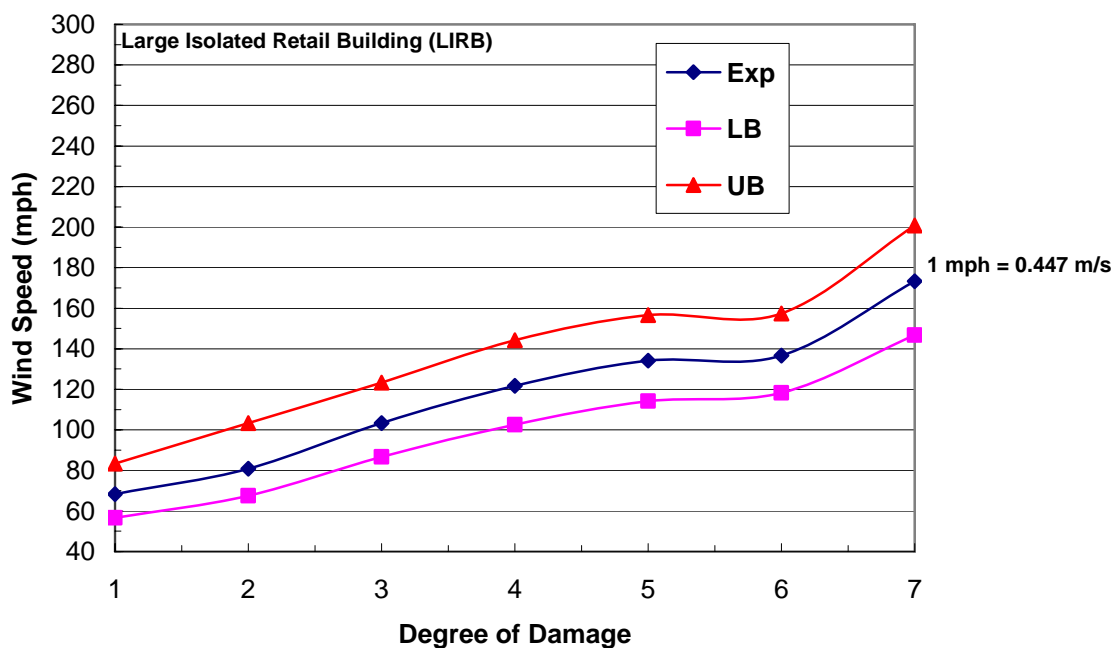
12. LARGE ISOLATED RETAIL BUILDING (LIRB)

Typical Construction

- Flat roof with BUR and gravel or single-ply membrane roof; generally has a 2-3 ft parapet
- Open web joists and steel girders or joist girders supported by tall pipe columns
- Metal deck with rigid insulation or lightweight concrete fill slab
- Large windows on front side of building
- CMU walls, tilt-up concrete panels, metal stud walls covered with EIFS or combinations of these

DOD*	Damage description	EXP	LB	UB
1	Threshold of visible damage	68	57	83
2	Loss of roof covering (<20%)	81	68	103
3	Uplift of some roof decking; significant loss of roofing material (>20%); loss of rooftop HVAC	103	87	123
4	Long roof spans collapsed downward	122	103	144
5	Uplift and removal of roof structure	134	114	157
6	Inward or outward collapse of exterior walls	137	118	158
7	Complete destruction of all or a large section of the building	173	147	201

* DOD is degree of damage



12. LARGE ISOLATED RETAIL BUILDING



LIRB: Flat roof with built-up tar and gravel roofing; 2-3 ft parapet; metal roof deck with rigid insulation; light steel roof structure; tilt-up concrete panel walls; glass store front



LIRB: DOD 2: Significant loss of roofing material; loss of rooftop HVAC



LIRB: DOD 6: Long span roof structure collapses downward

13. AUTOMOBILE SHOWROOM (ASR)

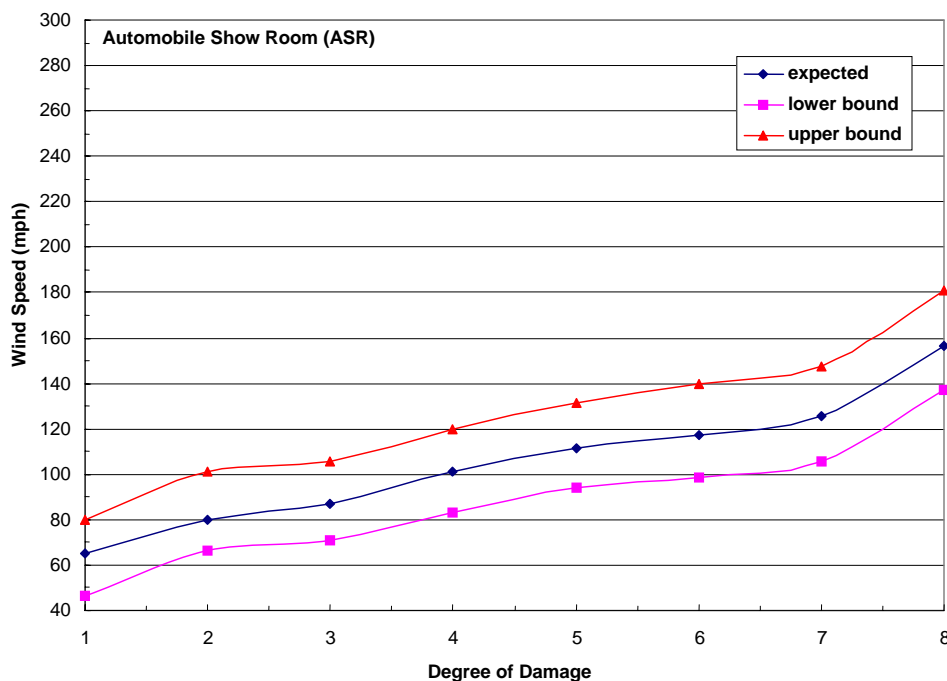
Typical Construction

- Most showrooms are single-story buildings with flat roof
- Roof system is BUR or single-ply membrane
- Metal roof deck or plywood panels
- Steel structural framing with open web steel joists
- Metal stud walls with EIFS, stucco or tilt-up panels
- Exterior walls on 2 or 3 sides have large glass windows

DOD*	Damage description	EXP	LB	UB
1	Threshold of visible damage	65	47	80
2	Loss of roof covering (<20%)	80	67	101
3	Broken glass in windows or doors	87	71	106
4	Uplift of some roof decking; significant loss of roofing material (>20%); loss of rooftop HVAC	101	83	120
5	Cladding stripped off walls	112	94	132
6	Uplift or collapse of roof structure	118	98	140
7	Exterior walls collapsed	126	106	148
8	Complete destruction of all or a large section of the building	157	138	181

* DOD is degree of damage

Wind Speed vs Degree of damage



13. AUTOMOBILE SHOWROOM (ASR)



ASR: Single story with flat roof; BUR or single-ply membrane;
metal or plywood roof deck; stud walls with EIFS,
stucco or tilt-up panels

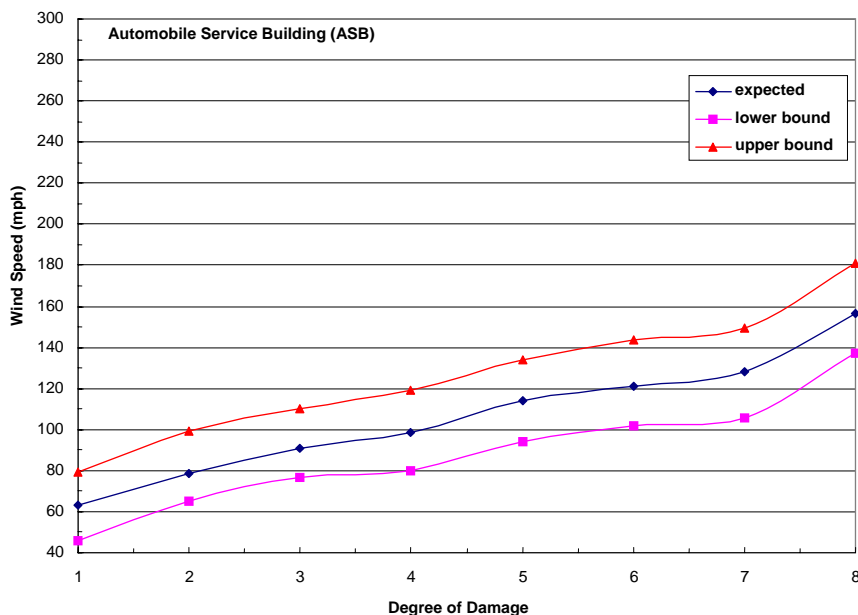
14. AUTOMOBILE SERVICE BUILDING (ASB)

General Description

- Single story building with flat roof and relatively tall walls with parapet
- Roof coverings are typically BUR with gravel or single-ply membrane
- Roof structure is light steel framing or open web steel joists and metal roof deck
- Exterior walls are concrete masonry or precast tilt-up panels
- Numerous large metal overhead doors

DOD*	Damage description	EXP	LB	UB
1	Threshold of visible damage	63	46	79
2	Loss of roof covering (<20%)	78	65	99
3	Failure of large overhead doors	91	77	110
4	Uplift of some roof decking; significant loss of roofing material (>20%); loss of rooftop HVAC	98	80	119
5	Collapse of non-bearing masonry or tilt-up walls	114	94	134
6	Uplift or collapse of roof structure	121	102	143
7	Collapse of load-bearing walls	128	106	149
8	Complete destruction of all or a large section of the building	157	138	181

* DOD is degree of damage



14. AUTOMOBILE SERVICE BUILDING (ASB)



ASB: Single story, flat roof, tall walls and parapet; BUR or single-ply roof covering; CMU or pre-cast tilt-up panels; numerous overhead doors

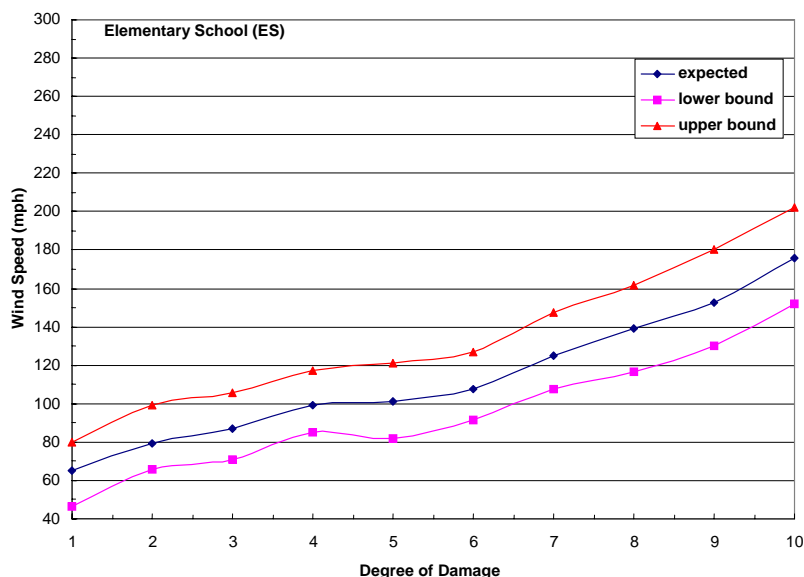
15. ELEMENTARY SCHOOL (ES)

General Description

- These buildings are typically single story with flat roofs
- Building may contain a small gym or cafeteria with moderately long spans between supports
- Buildings have long interior hallways with bearing or non-bearing walls
- BUR, single-ply membrane or metal standing seam roof panels
- Metal or plywood roof decking supporting rigid insulation boards or a light-weight poured gypsum deck
- Roof structure consists of open web steel joists bearing on exterior walls and steel interior girders
- Exterior non-bearing walls constructed with CMUs, glass curtain walls or metal studs with brick veneer, stucco or EIFS cladding
- CMU bearing walls with brick veneer, stucco or EIFS cladding
- Walls can have a large percentage of window glass

DOD*	Damage description	EXP	LB	UB
1	Threshold of visible damage	65	47	80
2	Loss of roof covering (<20%)	79	66	99
3	Broken windows	87	71	106
4	Exterior door failures	99	85	118
5	Uplift of some roof decking; significant loss of roofing material (>20%); loss of rooftop HVAC	101	82	121
6	Damage to or loss of wall cladding	108	92	127
7	Uplift or collapse of roof structure	125	108	148
8	Collapse of non-bearing walls	139	117	162
9	Collapse of load-bearing walls	153	130	180
10	Total destruction of a large section of building or entire building	176	152	203

* DOD is degree of damage



15. ELEMENTARY SCHOOL (ES)



ES: Single story with flat roof; built-up roofing with gravel; brick veneer; large percentage of window glass; long interior hallways; load-bearing walls



ES: DOD 5: Significant loss of roofing material (>20%); uplift of roof decking



ES: DOD 5: Significant loss of roofing material (>20%); uplift of roof decking



ES: DOD 8: Uplift of entire roof structure and collapse of non-bearing walls



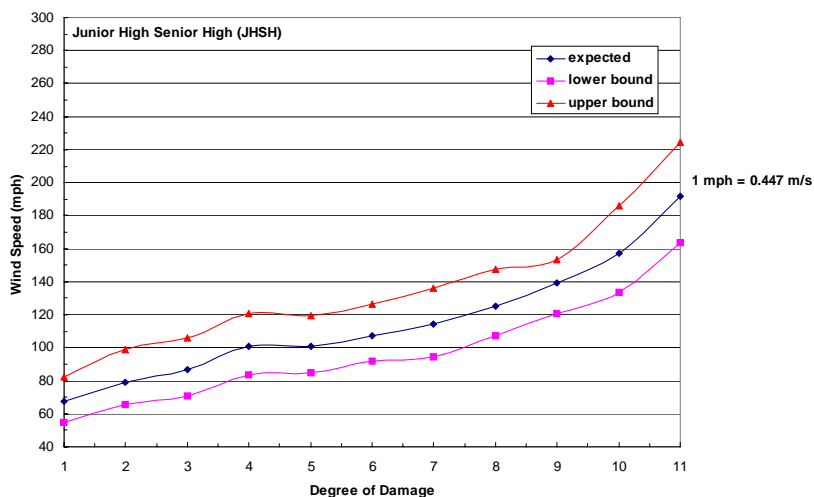
ES: DOD 9: Collapse of load-bearing walls

16. JUNIOR OR SENIOR HIGH SCHOOL (JHSH)

General Description

- Generally large one or two-story buildings with flat roofs
- May contain gymnasiums, cafeteria and auditorium with large structural spans; may have a basement
- Classroom wings have interior hallways with bearing or non-bearing interior walls
- BUR or single-ply membrane roof covering with or without gravel
- Structural system may consist of an all steel structure or an all reinforced concrete structure or a combination of both
- Roof structure may be light steel construction with open web joists supported on steel beams; corrugated metal roof deck with rigid insulation or poured gypsum deck
- Exterior walls constructed of concrete or clay blocks with brick veneer, stucco or EIFS; metal and glass curtain walls; walls may have more than 30% windows

DOD*	Damage description	EXP	LB	UB
1	Threshold of visible damage	68	55	83
2	Loss of roof covering (<20%)	79	66	99
3	Broken windows	87	71	106
4	Exterior door failures	101	83	121
5	Uplift of metal roof decking; significant loss of roofing material (>20%); loss of rooftop HVAC	101	85	119
6	Damage to or loss of wall cladding	108	92	127
7	Collapse of tall masonry walls at gym, cafeteria or auditorium	114	94	136
8	Uplift or collapse of light steel roof structure	125	108	148
9	Collapse of exterior walls in top floor	139	121	153
10	Most interior walls of top floor collapsed	158	133	186
11	Complete destruction of all or a large section of building	192	163	224



16. JUNIOR OR SENIOR HIGH SCHOOL (JHSH)



JHSH: Generally one or two story with flat roof; BUR or single-ply membrane roof with gravel; block walls with brick veneer, stucco or EIFS, metal or glass curtain walls; large percent window glass

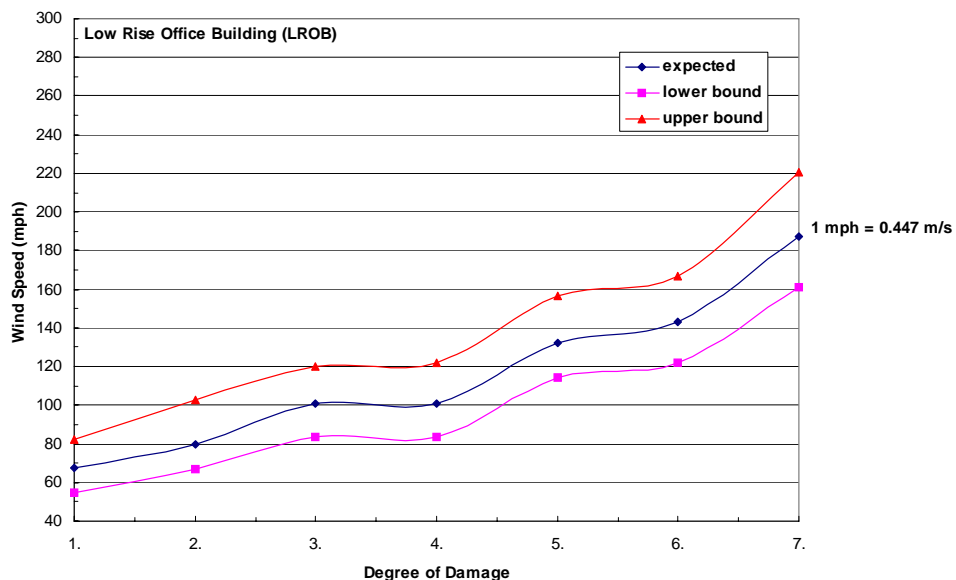
17. LOW-RISE BUILDING: 1 – 4 STORIES (LRB)

General Description

- Generally consist of rectangular modules but can be “odd shaped” in plan
- Most will have flat roofs but can have gable, hip or mansard shapes
- Roofing materials include BUR, single-ply membrane, metal panels or standing seam
- Roof deck is wood or metal deck, poured gypsum deck or concrete slab
- Steel or reinforced concrete structural frame
- Glass and metal curtain walls, metal studs with EIFS, non-bearing masonry walls with stucco or brick veneer
- Examples are office buildings, medical facilities, and bank buildings.

DOD*	Damage description	EXP	LB	UB
1	Threshold of visible damage	68	55	83
2	Loss of roof covering (<20%)	80	67	103
3	Uplift of metal roof decking at eaves and roof corners: significant loss of roofing material (>20%)	101	83	120
4	Broken glass in windows, entryways or atriums	101	83	122
5	Uplift of lightweight roof structure	133	114	157
6	Significant damage to exterior walls and some interior walls	143	122	167
7	Complete destruction of all or a large section of building	188	161	221

* DOD is degree of damage



17. LOW-RISE BUILDING 1-4 STORIES (LRB)



LRB: Rectangular modules but can be “odd shaped”; flat, gable, hip or mansard roof shapes; BUR, single-ply membrane or metal panel roof system; wood, metal, poured gypsum or concrete roof deck; glass or metal curtain walls, metal studs with EIFS, stucco or brick veneer, masonry bearing walls

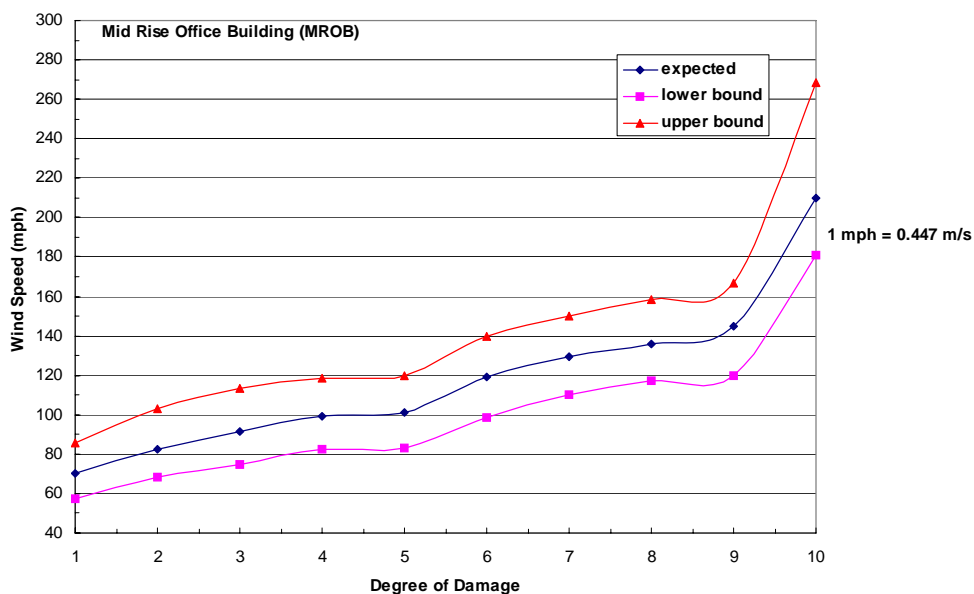
18. MID-RISE BUILDING: 5 – 20 STORIES (MROB)

General Description

- Generally consist of rectangular shapes but can have curved or triangular footprints
- Roofs are generally flat; may have an elevator/mechanical penthouse; parapet walls
- Structural frame is steel or reinforced concrete
- Roofing materials are BUR or single-ply membrane with or without gravel
- Penthouse is steel framing with metal panels, or metal studs with stucco or EIFS
- Exterior cladding is glass or metal curtain walls; pre-cast concrete window wall panels or a combination of the two
- Roof structure consists of metal deck, poured gypsum deck or concrete slab
- Examples are office buildings, medical facilities, and residential buildings

DOD*	Damage description	EXP	LB	UB
1	Threshold of visible damage	70	58	86
2	Loss of roof covering (<20%)	83	68	103
3	Damage to penthouse roof and walls; loss of rooftop HVAC equipment	92	75	113
4	Damage to parapet walls or coping	99	83	118
5	Broken glass in curtain walls; glass in entryways; significant damage to building interior	101	83	120
6	Uplift of lightweight roof decking; significant loss of roofing material (>20%)	119	98	140
7	Broken curtain wall panel anchors	129	110	150
8	Uplift or collapse of roof structure	136	118	158
9	Significant damage to curtain walls and some interior walls	145	120	167
10	Permanent structural deformation	210	181	268

- DOD is degree of damage



18. MID-RISE BUILDING 5-20 STORIES (MRB)



MRB: Generally rectangular shapes; flat roof with parapet and penthouse; BUR or single-ply membrane with or without gravel; metal deck, poured gypsum or concrete deck; glass or metal curtain walls, marble panels or pre-cast concrete wall panels



MRB: DOD 5: Broken glass in curtain walls; damage to building interior



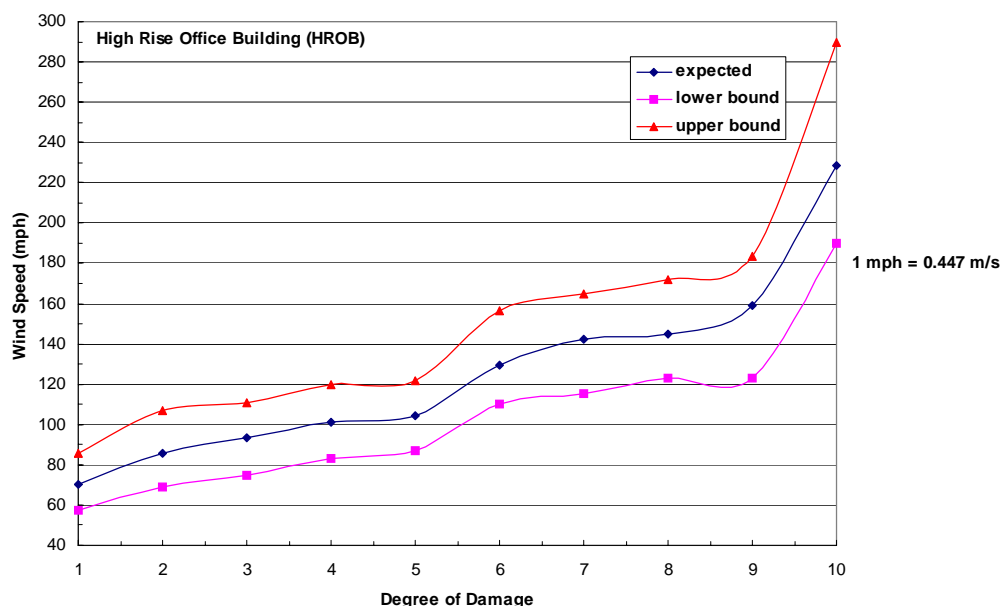
MRB: DOD 9: Significant damage to curtain walls and some interior walls

19. HIGH-RISE BUILDING: GREATER THAN 20 STORIES (HROB)

General Description

- Generally consist of rectangular shapes but can have curved or triangle footprints
- Roofs are generally flat but may have a more complex roof shape as part of esthetic statement
- Roofing material single-ply membrane fully adhered, polyurethane foam roof, metal or copper clad roof covering
- Penthouse is steel framing with metal panels
- Structural frame is steel or reinforced concrete
- Exterior cladding is glass or metal curtain walls or pre-cast concrete window panels
- First floor often has very large glass areas that are susceptible to debris impact
- Atriums with overhead glazing or tall window walls
- Examples are hotels, office buildings, and condominiums

DOD*	Damage description	EXP	LB	UB
1	Threshold of visible damage	70	58	86
2	Loss of roof covering (<20%)	86	69	107
3	Damage to penthouse roof and walls; loss of rooftop HVAC equipment	93	75	111
4	Broken glass in exterior walls at 1 st and 2 nd floors; broken glass in entryways	101	83	120
5	Damage to parapet walls or coping	104	87	122
6	Broken curtain wall panel anchors	129	110	157
7	Significant loss of roofing material (>20%)	143	115	165
8	Significant damage to curtain walls and interior walls	145	123	172
9	Uplift or collapse of roof structure	159	123	183
10	Permanent structural deformation	228	190	290



19. HIGH-RISE BUILDING – GREATER THAN 20 STORIES (HRB)



HRB: Rectangular or complex shape; flat or complex roof shape;
Single-ply membrane, polyurethane foam, metal or copper roof system;
penthouse; glass or metal curtain wall, masonry,
or pre-cast concrete wall panels



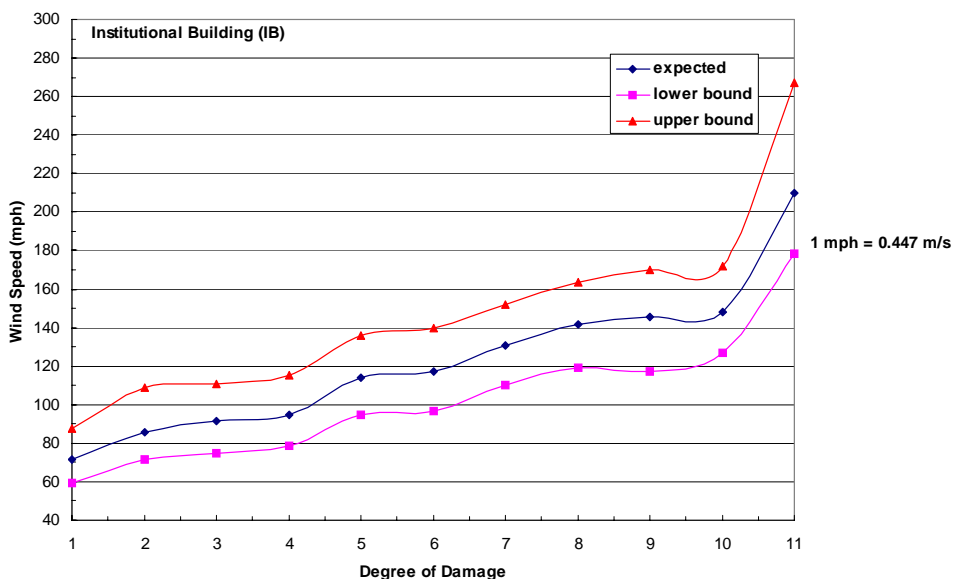
HRB: DOD 8: Broken glass in curtain wall; significant damage to building interior

20. INSTITUTIONAL BUILDING (IB)

General Description

- Examples are hospitals, courthouses, university buildings, state and federal buildings, jails
- Range in height from 1 – 10 stories
- Roofing materials include fully adhered and mechanically fastened single-ly membranes, polyurethane foam, copper clad domes
- Structure is normally reinforced concrete
- Walls are masonry with cut stone or precast panels – very ornate
- Balcones, porches and porticos with heavy façade
- Relatively small windows

DOD*	Damage description	EXP	LB	UB
1	Threshold of visible damage	72	59	88
2	Loss of roof covering (<20%)	86	72	109
3	Damage to penthouse roof and walls; loss of rooftop HVAC equipment	92	75	111
4	Broken glass in windows or doors	95	78	115
5	Uplift of lightweight roof deck and insulation; significant loss of roofing material (>20%)	114	95	136
6	Façade components torn from structure	118	97	140
7	Damage curtain walls or other wall cladding	131	110	152
8	Uplift of pre-cast concrete roof slabs	142	119	163
9	Uplift of metal deck with concrete fill slab	146	118	170
10	Collapse of some top story exterior walls	148	127	172
11	Complete destruction of all or a large portion of building	210	268	



20. INSTITUTIONAL BUILDING (IB)



IB: Height from 1 to 10 stories; single-ply membrane, polyurethane foam or metal roof systems; masonry, cut-stone or pre-cast wall panels; balconies, porches or porticos; heavy façade; relatively small windows



IB: DOD 5: Uplift of light-weight roof deck and insulation;
significant loss of roofing material (>20%)

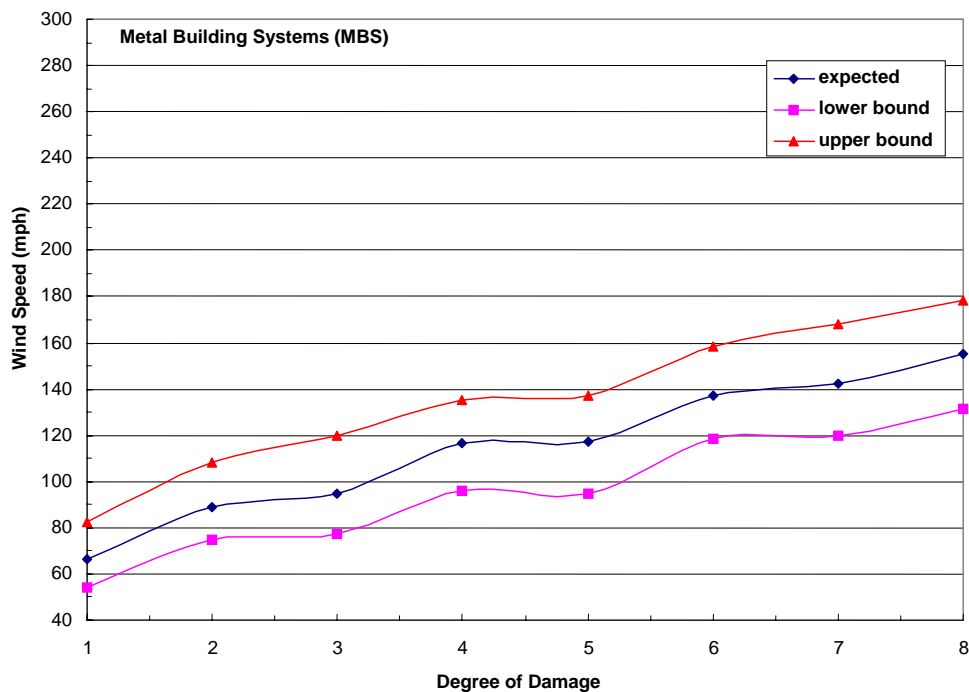
21. METAL BUILDING SYSTEMS (MBS)

General Description

- Examples are warehouses, industrial facilities, small arenas
- Metal panel walls and standing seam roof
- Nearly always have a gable roof and relatively tall walls
- Large overhead doors
- Large-span single bay rigid frames
- Z or C-shaped purlins and girts span between rigid frames
- Lateral loads resisted by x-bracing in direction parallel to ridge
- Relatively weak end-wall frames

DOD*	Damage description	EXP	LB	UB
1	Threshold of visible damage	67	54	83
2	Inward or outward collapsed of overhead doors	89	75	108
3	Metal roof or wall panels pulled from the building	95	78	120
4	Column anchorage failed	117	96	135
5	Buckling of roof purlins	118	95	138
6	Failure of X-braces in the lateral load resisting system	138	118	158
7	Progressive collapse of rigid frames	143	120	168
8	Total destruction of building	155	132	178

* DOD is degree of damage



21. METAL BUILDING SYSTEM (MBS)



MBS: Metal roof and wall panels; gable roof shape; Z or C-shaped purlins and girts; single-bay rigid frames; x-bracing parallel to ridge



MBS: DOD 7: Progressive collapse of rigid frames



MBS: DOD 8: Total destruction of building

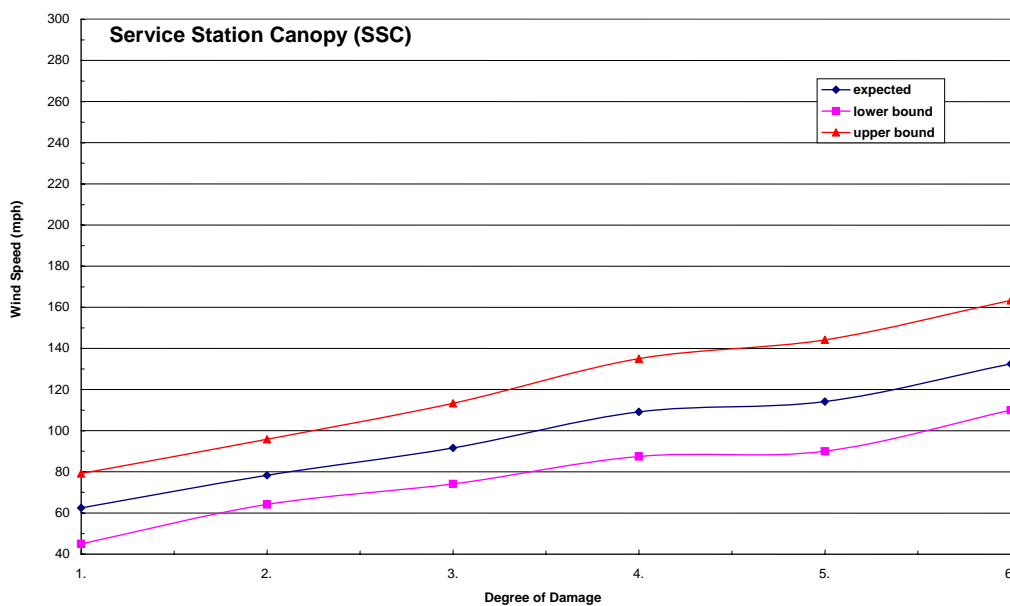
22. SERVICE STATION CANOPY (SSC)

Typical Construction

- Modern service stations consist of a very large canopy covering the entire pump area and small building that houses cashier and retail space
- Canopy structure constructed of steel beam framework supported on 4 or more tall columns
- Metal panels cover bottom side of the canopy
- Light weight fascia materials, either metal or plastic, cover the perimeter of canopy

DOD*	Damage description	EXP	LB	UB
1	Threshold of visible damage	63	45	79
2	Fascia material blown from canopy	78	64	96
3	Metal roof panels stripped from canopy	92	74	113
4	Columns bend or buckle under wind load	109	88	135
5	Canopy collapsed due to column foundation failure	114	90	144
6	Complete destruction of canopy	133	110	163

*Degree of Damage



22. SERVICE STATION CANOPY (SSC)



SSC: Large rectangular free-standing canopy supported on columns; metal panels cover bottom side of canopy; metal or plastic fascia materials cover perimeter of canopy

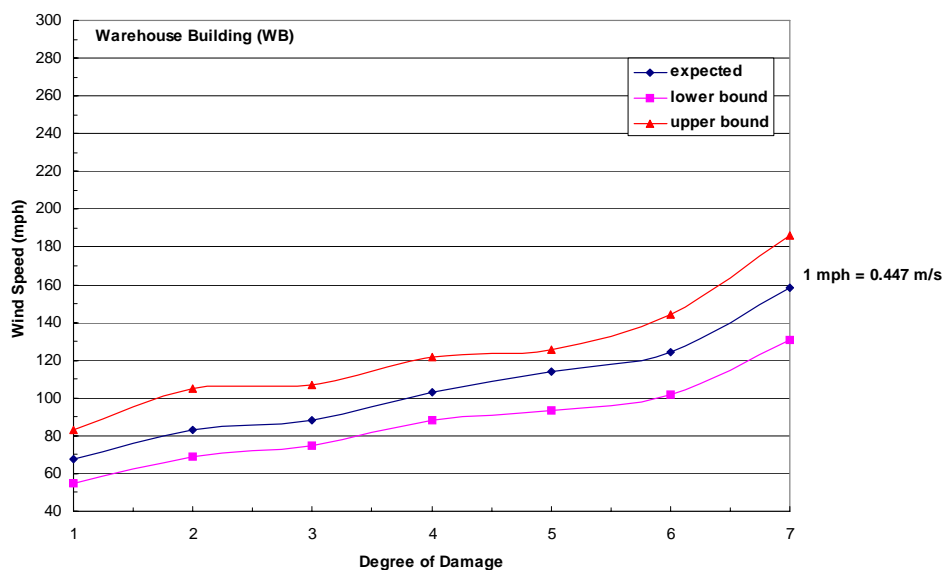
23. WAREHOUSE BUILDING (WHB)

General Description

- This category includes all building systems except Metal Building Systems
- Examples include warehouse, storage and industrial buildings
- Buildings are generally rectangular in plan with flat, gable or hip roofs
- Built-up roofs with gravel, single-ply membrane ballasted, mechanically attached or fully adhered
- Light-frame steel construction with masonry bearing walls
- Large overhead doors
- Pre-cast concrete columns, beams and double tees with tilt-up wall panels
- Heavy timber construction with stud walls and wood panels

DOD*	Damage description	EXP	LB	UB
1	Threshold of visible damage	68	55	83
2	Loss of roofing material (<20%)	83	69	105
3	Inward or outward collapse of overhead doors	88	75	107
4	Uplift of roof deck; significant loss of roofing material (>20%); loss of rooftop HVAC equipment	103	88	122
5	Collapse of other non-bearing exterior walls	114	93	126
6	Collapse of pre-cast concrete tilt-up panels	124	102	144
7	Total destruction of a large section of building or entire building	158	131	186

* DOD is degree of damage



23. WAREHOUSE BUILDING (WHB)



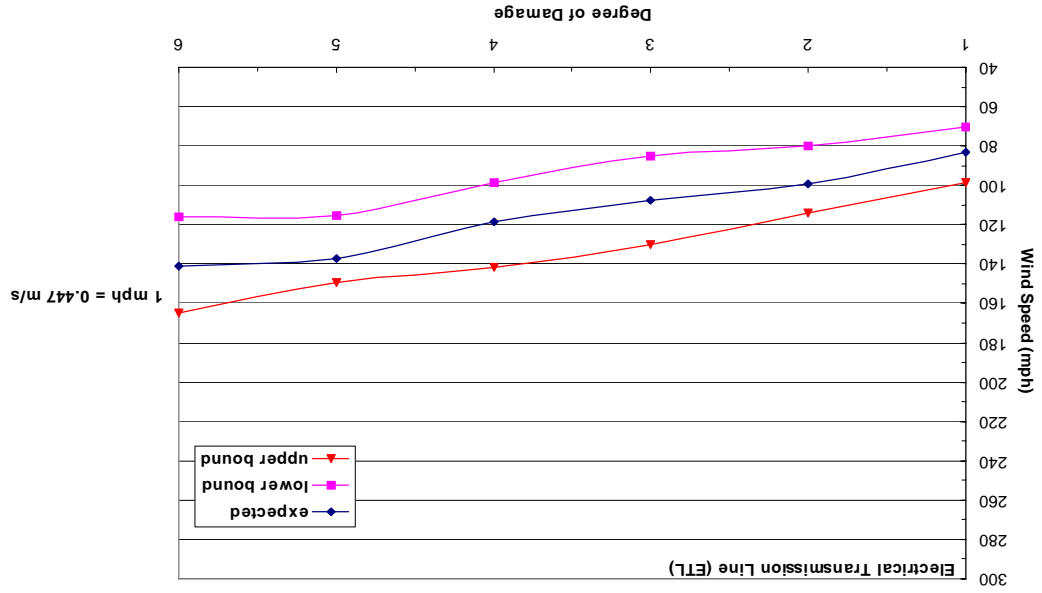
WHB: Rectangular in plan with flat roof; BUR or single-ply membrane roofing system with or without gravel; masonry bearing walls, tilt-up precast concrete wall panels or stud walls with wood panels; large overhead doors



WHB: DOD 5: Collapse of non-bearing exterior wall



WHB: DOD 7: Total destruction of a large section of building



DOD*	Damage description	EXP	LB	UB
1	Threshold of visible damage	83	70	98
2	Broken wood cross member	99	80	114
3	Wood poles leaning	108	85	130
4	Broken wood poles	118	98	142
5	Broken or bent steel or concrete poles	138	115	149
6	Collapsed metal truss towers	141	116	165

* DOD is degree of damage

- Single wood poles with wood cross arms
- Single steel or concrete poles with metal cross arms
- Metal trussed towers

Typical Construction

24. ELECTRICAL TRANSMISSION LINE (ETL)

24. ELECTRICAL TRANSMISSION LINE (ETL)



ETL: Single Wood Pole



ETL: Single Steel Pole



ETL: Metal Truss Tower

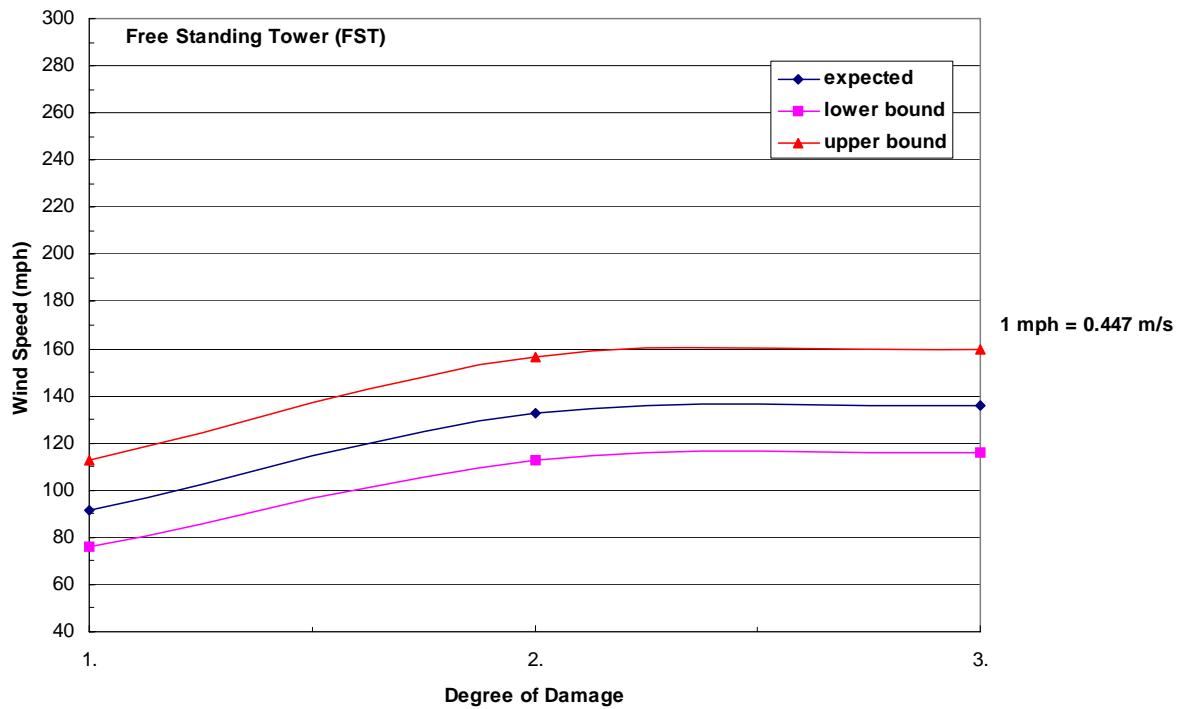
25. FREE-STANDING TOWERS (FST)

Typical Construction

- Cell phone pole or tower
- Microwave tower

DOD*	Damage description	EXP	LB	UB
1	Threshold of visible damage	92	76	113
2	Collapsed cell-phone pole or tower	133	113	157
3	Collapsed micro-wave tower	136	116	160

* DOD is degree of damage



25. FREE-STANDING TOWERS (FST)



FST: Free-standing Truss Tower

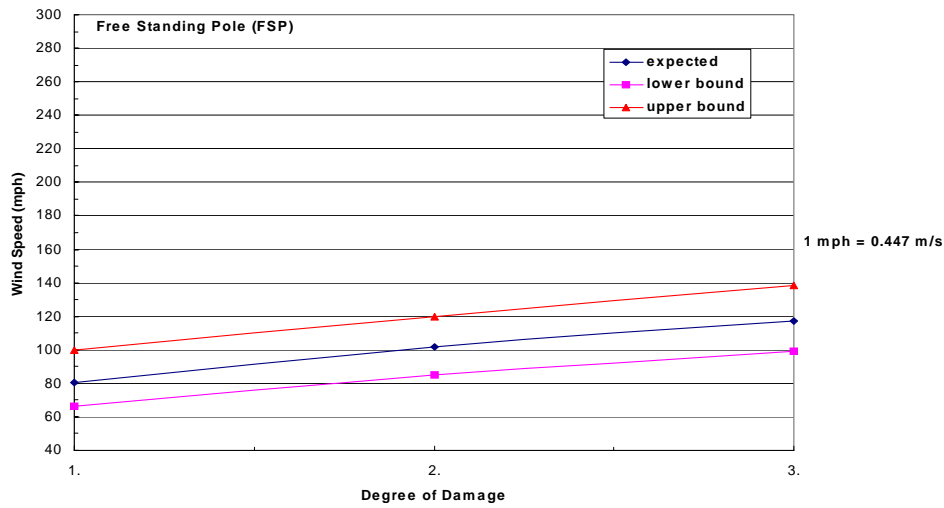
26. FREE-STANDING LIGHT POLES, LUMINARY POLES, FLAG POLES (FSP)

Typical Construction

- Cantilevered metal pole

DOD*	Damage description	EXP	LB	UB
1	Threshold of visible damage	81	67	100
2	Bent pole	102	85	120
3	Collapsed pole	118	99	138

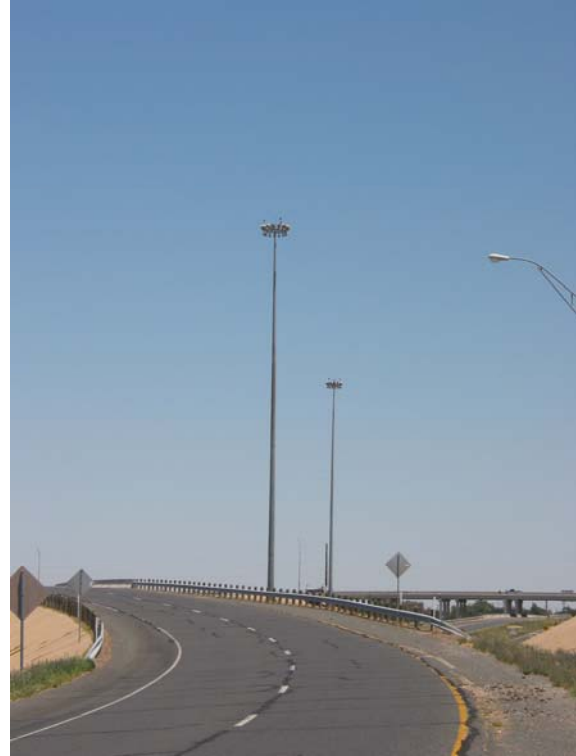
* DOD is degree of damage



26. FREE-STANDING LIGHT POLES, LUMINARY POLES, FLAG POLES (FSP)



FSP: Light Poles



FSP: Luminary Poles

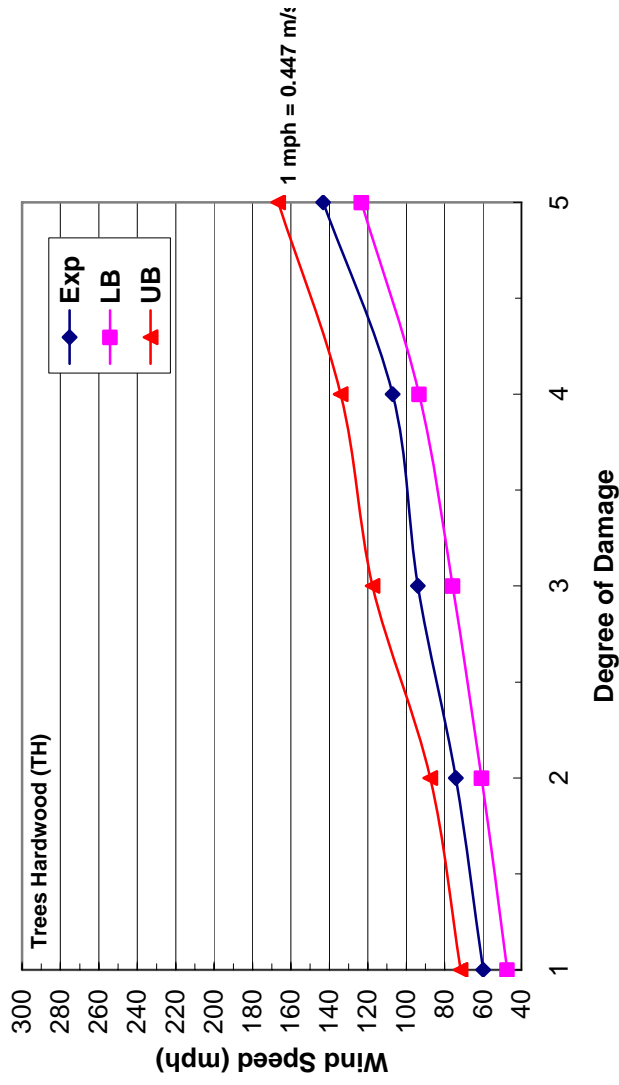
27. TREES: HARDWOOD

Typical Construction

- Hardwood: Oak, Maple, Birch, Ash

DOD*	Damage description	EXP	LB	UB
1	Small limbs broken (up to 1" diameter)	60	48	72
2	Large branches broken (1"-3" diameter)	74	61	88
3	Trees uprooted	94	76	118
4	Trunks snapped	107	93	134
5	Trees debarked with only stubs of largest branches remaining	143	123	167

- DOD is degree of damage



27. TREES HARDWOOD (TH)



TH: Oak, Maple, Birch, Ash



TH: DOD 3: Tree uprooted



TH: DOD 5: Tree debarked with only stubs of largest branches remaining

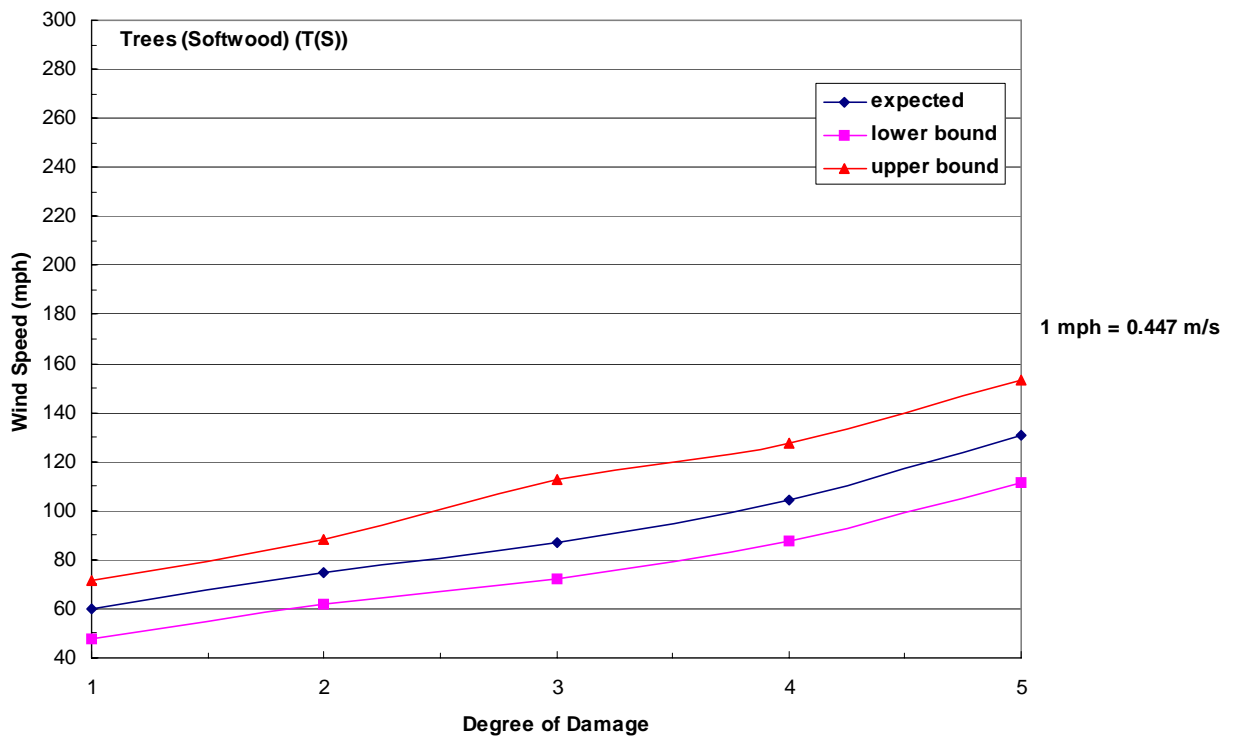
28. TREES (SOFTWOOD)

Typical Construction

- Softwood: Pine, Spruce, Fir, Hemlock, Cedar, Redwood, Cypress

DOD	Damage description	EXP	LB	UB
1	Small limbs broken (up to 1" diameter)	60	48	72
2	Large branches broken (1" – 3" diameter)	75	62	88
3	Trees uprooted	87	73	113
4	Trunks snapped	104	88	128
5	Trees debarked with only stubs of largest branches remaining	131	112	153

* DOD is degree of damage



Appendix B

EXPERT ELICITATION OF DAMAGE VERSUS WIND SPEED

Small Barns or Farm Buildings

Bldg	Damage Indicator	Expected Values						Mean	Std Dev
		1	2	3	4	5	6		
SBO	1.0	50	70	70	55	65	60	61.67	1.18
	2.0	65	80	85	65	70	80	74.17	4.12
	3.0	80	90	85	75	85	80	82.50	1.77
	4.0	70	110	90	75	95	100	90.00	7.07
	5.0	80	100	100	85	90	100	92.50	5.30
	6.0	80	110	95	95	100	100	96.67	2.36
	7.0	80	120	110	85	100	100	99.17	0.59
	8.0	100	130	115	115	110	100	111.67	8.25

One and Two-Family Residences

Bldg	Damage Indicator	Expected Values						Mean	Std Dev
		1	2	3	4	5	6		
FR12	1	60	80	70	60	60	60	65.00	8.37
	2	70	90	85	70	80	80	79.17	8.01
	3	75	130	85	80	105	100	95.83	20.35
	4	85	110	100	85	100	100	96.67	9.83
	5	120	130	110	120	120	125	120.83	6.65
	6	85	140	120	140	120	125	121.67	20.17
	7	125	120	115	150	125	155	131.67	16.63
	8	125	160	130	165	135	170	147.50	19.69
	9	130	160	150	165	150	155	151.67	12.11
	10	130	170	160	200	170	190	170.00	24.49

Manufactured Home Single Wide

Bldg	Damage Indicator	Expected Values						Mean	Std Dev
		1	2	3	4	5	6		
MHSW	1	50	70	65	60	60	60	60.83	6.65
	2	65	80	70	70	80	80	74.17	6.65
	3	70	100	90	90	90	80	86.67	10.33
	4	75	100	90	90	90	90	89.17	8.01
	5	90	110	100	95	100	90	97.50	7.58
	6	100	120	100	100	110	100	105.00	8.37
	7	100	120	110	115	110	100	109.17	8.01
	8	120	120	110	120	125	115	118.33	5.16
	9	120	130	120	130	135	125	126.67	6.06

EXPERT ELICITATION OF DAMAGE VERSUS WIND SPEED

Manufactured Home Double Wide

Bldg	Damage Indicator	Expected Values						Mean	Std Dev
		1	2	3	4	5	6		
MHDW	1	50	70	65	60	60	60	60.83	6.65
	2	65	80	80	70	80	80	75.83	6.65
	3	75	80	70	80	85	80	78.33	5.16
	4	75	100	80	80	80	80	82.50	8.80
	5	75	100	85	80	85	100	87.50	10.37
	6	80	110	100	90	90	90	93.33	10.33
	7	80	110	110	90	95	80	94.17	13.57
	8	80	110	95	100	95	100	96.67	9.83
	9	100	120	110	120	115	110	112.50	7.58
	10	110	130	120	120	105	100	114.17	11.14
	11	120	130	125	135	130	120	126.67	6.06
	12	120	140	130	150	135	130	134.17	10.21

Apartments, Townhouses, Condos

Bldg	Damage Indicator	Expected Values						Mean	Std Dev
		1	2	3	4	5	6		
ACT	1	65	90	70	70	80	80	75.83	9.17
	2	80	110	120	85	100	100	99.17	14.97
	3	120	130	130	120	120	125	124.17	4.92
	4	130	140	140	150	130	140	138.33	7.53
	5	140	150	150	190	165	155	158.33	17.51
	6	160	180	160	220	170	190	180.00	22.80

Motels

Bldg	Damage Indicator	Expected Values						Mean	Std Dev
		1	2	3	4	5	6		
M	1	65	80	70	60	60	60	65.83	8.01
	2	75	90	85	70	80	80	80.00	7.07
	3	75	110	90	80	80	100	89.17	13.57
	4	85	110	90	85	100	100	95.00	10.00
	5	80	110	90	110	105	100	99.17	12.01
	6	120	130	125	120	120	125	123.33	4.08
	7	130	130	130	150	130	155	137.50	11.73
	8	130	140	135	165	130	155	142.50	14.40
	9	160	160	160	200	150	190	170.00	20.00
	10	160	180	170	230	170	230	190.00	31.62

EXPERT ELICITATION OF DAMAGE VERSUS WIND SPEED

Masonry Apartment or Motel

Bldg	Damage Indicator	Expected Values						Mean	Std Dev
		1	2	3	4	5	6		
MAMB	1.	65	80	65	60	60	60	65.00	7.75
	2.	75	90	85	70	80	80	80.00	7.07
	3.	100	100	95	85	100	90	95.00	6.32
	4.	120	120	105	130	150	100	120.83	18.00
	5.	130	120	115	165	140	125	132.50	18.10
	6.	160	140	130	190	160	155	155.83	20.60
	7.	180	160	150	220	180	190	180.00	24.49

Small Retail Building

Bldg	Damage Indicator	Expected Values						Mean	Std Dev
		1	2	3	4	5	6		
SRB	1	65	80	65	60	60	60	65.00	7.75
	2	65	90	85	70	80	80	78.33	9.31
	3	65	100	100	90	80	80	85.83	13.57
	4	80	110	110	85	100	100	97.50	12.55
	5	70	100	90	120	105	100	97.50	16.66
	6	100	120	130	120	120	125	119.17	10.21
	7	120	140	140	160	130	140	138.33	13.29
	8	140	160	150	230	165	155	166.67	32.20

Small Professional Building

Bldg	Damage Indicator	Expected Values						Mean	Std Dev
		1	2	3	4	5	6		
SPB	1	65	80	65	60	60	60	65.00	7.75
	2	65	90	85	70	80	80	78.33	9.31
	3	65	100	100	90	80	100	89.17	14.29
	4	65	130	95	90	120	100	100.00	23.02
	5	80	110	110	100	100	100	100.00	10.95
	6	80	110	120	100	110	100	103.33	13.66
	7	120	130	130	120	120	125	124.17	4.92
	8	130	140	140	160	140	155	144.17	11.14
	9	140	160	150	130	170	190	156.67	21.60

EXPERT ELICITATION OF DAMAGE VERSUS WIND SPEED

Strip Mall

Bldg	Damage Indicator	Expected Values						Mean	Std Dev
		1	2	3	4	5	6		
SM	1	65	80	65	60	60	60	65.00	7.75
	2	70	90	90	70	80	80	80.00	8.94
	3	65	100	110	90	80	80	87.50	16.05
	4	100	110	110	85	100	100	100.83	9.17
	5	80	110	120	100	110	100	103.33	13.66
	6	100	100	95	120	105	100	103.33	8.76
	7	120	120	130	120	120	120	121.67	4.08
	8	140	130	140	160	140	130	140.00	10.95
	9	160	150	150	230	180	155	170.83	31.05

Large Shopping Mall

Bldg	Damage Indicator	Expected Values						Mean	Std Dev
		1	2	3	4	5	6		
LSM	1	65	90	65	75	60	70	70.83	10.68
	2	65	110	90	85	80	80	85.00	14.83
	3	75	100	100	95	80	100	91.67	11.25
	4	100	130	110	110	100	100	108.33	11.69
	5	100	110	110	110	110	125	110.83	8.01
	6	110	140	120	130	125	140	127.50	11.73
	7	120	150	140	160	140	155	144.17	14.29
	8	130	160	150	170	160	190	160.00	20.00
	9	200	180	160	260	195	230	204.17	35.84

Large Isolated Retail Building

Bldg	Damage Indicator	Expected Values						Mean	Std Dev
		1	2	3	4	5	6		
LIRB	1	65	80	65	70	60	70	68.33	1.87
	2	65	90	90	80	80	80	80.83	6.83
	3	100	110	110	100	100	100	103.33	9.17
	4	120	120	130	120	115	125	121.67	5.16
	5	120	140	140	130	120	155	134.17	5.16
	6	120	120	140	140	130	170	136.67	13.57
	7	160	140	150	230	170	190	173.33	18.62

EXPERT ELICITATION OF DAMAGE VERSUS WIND SPEED

Automobile Showroom

Bldg	Damage Indicator	Expected Values						Mean	Std Dev
		1	2	3	4	5	6		
ASR	1	50	80	70	70	60	60	65.00	10.49
	2	65	90	85	80	80	80	80.00	8.37
	3	65	100	105	90	80	80	86.67	14.72
	4	85	110	110	100	100	100	100.83	9.17
	5	85	100	120	130	110	125	111.67	16.93
	6	100	110	130	120	120	125	117.50	10.84
	7	100	110	140	140	130	135	125.83	16.86
	8	120	120	150	230	165	155	156.67	40.46

Automobile Service Building

Bldg	Damage Indicator	Expected Values						Mean	Std Dev
		1	2	3	4	5	6		
ASB	1	50	80	70	60	60	60	63.33	10.33
	2	65	90	85	70	80	80	78.33	9.31
	3	70	100	95	90	90	100	90.83	11.14
	4	85	110	110	85	100	100	98.33	11.25
	5	100	110	120	130	125	100	114.17	12.81
	6	100	120	130	130	120	125	120.83	11.14
	7	110	120	130	150	135	125	128.33	13.66
	8	120	130	150	220	165	155	156.67	35.17

Elementary School

Bldg	Damage Indicator	Expected Values						Mean	Std Dev
		1	2	3	4	5	6		
ES	1	50	80	70	70	60	60	65.00	10.49
	2	65	90	85	75	80	80	79.17	8.61
	3	65	100	105	90	80	80	86.67	14.72
	4	65	120	100	90	120	100	99.17	20.60
	5	85	110	110	100	100	100	100.83	9.17
	6	75	120	120	120	110	100	107.50	17.82
	7	120	120	130	130	125	125	125.00	4.47
	8	140	120	130	150	140	155	139.17	12.81
	9	100	140	140	175	170	190	152.50	32.52
	10	160	140	150	230	185	190	175.83	32.93

EXPERT ELICITATION OF DAMAGE VERSUS WIND SPEED

Junior or Senior High School

Bldg	Damage Indicator	Expected Values						Mean	Std Dev
		1	2	3	4	5	6		
JHSH	1	65	80	70	70	60	60	67.50	7.58
	2	65	90	85	75	80	80	79.17	8.61
	3	65	100	105	90	80	80	86.67	14.72
	4	65	130	100	90	120	100	100.83	22.89
	5	85	110	110	100	100	100	100.83	9.17
	6	75	120	120	120	110	100	107.50	17.82
	7	75	120	120	150	120	100	114.17	24.98
	8	120	120	130	130	125	125	125.00	4.47
	9	130	120	140	150	140	155	139.17	12.81
	10	140	140	140	175	160	190	157.50	21.39
	11	180	140	150	240	210	230	191.67	41.67

Low-Rise Building

Bldg	Damage Indicator	Expected Values						Mean	Std Dev
		1	2	3	4	5	6		
LRB	1	65	80	70	70	60	60	67.50	7.58
	2	65	90	85	80	80	80	80.00	8.37
	3	85	110	110	100	100	100	100.83	9.17
	4	100	100	110	90	80	125	100.83	15.63
	5	120	120	140	130	130	155	132.50	13.32
	6	130	120	130	150	140	190	143.33	25.03
	7	160	140	180	230	185	230	187.50	36.57

Mid-Rise Building

Bldg	Damage Indicator	Expected Values						Mean	Std Dev
		1	2	3	4	5	6		
MRB	1	65	80	70	75	60	70	70.00	7.07
	2	65	100	85	85	80	80	82.50	11.29
	3	85	100	85	100	80	100	91.67	9.31
	4	75	100	100	100	120	100	99.17	14.29
	5	100	100	110	90	80	125	100.83	15.63
	6	120	120	110	120	120	125	119.17	4.92
	7	120	110	120	130	140	155	129.17	16.25
	8	120	120	140	130	150	155	135.83	14.97
	9	130	120	130	160	140	190	145.00	25.88
	10	200	180	190	260	200	230	210.00	29.66

EXPERT ELICITATION OF DAMAGE VERSUS WIND SPEED

High-Rise Building

Bldg	Damage Indicator	Expected Values						Mean	Std Dev
		1	2	3	4	5	6		
HRB	1	65	80	70	75	60	70	70.00	7.07
	2	65	100	85	85	100	80	85.83	13.20
	3	85	100	95	100	80	100	93.33	8.76
	4	100	100	110	90	80	125	100.83	15.63
	5	75	110	100	110	130	100	104.17	18.00
	6	120	110	120	130	140	155	129.17	16.25
	7	120	130	110	120	250	125	142.50	53.08
	8	130	110	130	170	140	190	145.00	29.50
	9	120	130	140	140	270	155	159.17	55.54
	10	200	180	190	270	300	230	228.33	47.92

Institutional Building

Bldg	Damage Indicator	Expected Values						Mean	Std Dev
		1	2	3	4	5	6		
IB	1	65	80	70	75	60	80	71.67	8.16
	2	65	100	85	85	80	100	85.83	13.20
	3	85	100	85	100	80	100	91.67	9.31
	4	65	100	110	90	80	125	95.00	21.45
	5	120	120	110	110	100	125	114.17	9.17
	6	100	130	100	120	130	125	117.50	14.05
	7	100	120	140	130	140	155	130.83	19.08
	8	120	140	135	150	150	155	141.67	12.91
	9	120	150	120	130	230	125	145.83	42.71
	10	120	130	150	160	140	190	148.33	24.83
	11	200	180	190	250	210	230	210.00	26.08

Metal Building System

Bldg	Damage Indicator	Expected Values						Mean	Std Dev
		1	2	3	4	5	6		
MBS	1	65	80	70	65	60	60	66.67	7.53
	2	80	90	85	90	90	100	89.17	6.65
	3	80	100	110	100	80	100	95.00	12.25
	4	100	120	115	120	120	125	116.67	8.76
	5	100	130	120	110	120	125	117.50	10.84
	6	120	130	150	140	130	155	137.50	13.32
	7	120	140	140	180	120	155	142.50	22.75
	8	120	150	150	220	135	155	155.00	34.35

EXPERT ELICITATION OF DAMAGE VERSUS WIND SPEED

Bldg	Damage Indicator	Expected Values						Mean	Std Dev
		1	2	3	4	5	6		
SSC	1	50	70	65	70	60	60	62.50	7.58
	2	65	80	85	80	80	80	78.33	6.83
	3	75	100	95	100	80	100	91.67	11.25
	4	85	120	120	110	120	100	109.17	14.29
	5	85	120	130	120	120	110	114.17	15.63
	6	100	130	130	140	170	125	132.50	22.75

Warehouse Building

Bldg	Damage Indicator	Expected Values						Mean	Std Dev
		1	2	3	4	5	6		
WB	1	65	80	70	70	60	60	67.50	7.58
	2	75	100	85	80	80	80	83.33	8.76
	3	75	90	85	90	90	100	88.33	8.16
	4	90	120	110	100	100	100	103.33	10.33
	5	90	110	130	130	125	100	114.17	16.86
	6	100	130	140	140	125	110	124.17	16.25
	7	140	140	140	240	165	125	158.33	42.03

Electrical Transmission Line

Bldg	Damage Indicator	Expected Values						Mean	Std Dev
		1	2	3	4	5	6		
ETL	1	65	80	85	90	100	80	83.33	11.69
	2	80	100	110	100	105	100	99.17	10.21
	3	80	100	120	110	110	125	107.50	16.05
	4	100	120	115	130	120	125	118.33	10.33
	5	120	140	130	150	130	155	137.50	13.32
	6	120	130	140	170	130	155	140.83	18.55

Bldg	Damage Indicator	Expected Values						Mean	Std Dev
		1	2	3	4	5	6		
FST	1.	65	100	90	110	105	80	91.67	16.93
	2.	120	120	130	170	130	125	132.50	18.91
	3.	120	120	130	170	120	155	135.83	21.54

EXPERT ELICITATION OF DAMAGE VERSUS WIND SPEED

Free-Standing Light Poles, Luminary Poles, Flag Poles

Bldg	Damage Indicator	Expected Values						Mean	Std Dev
		1	2	3	4	5	6		
FST	1	65	100	90	110	105	80	91.67	16.93
	2	120	120	130	170	130	125	132.50	18.91
	3	120	120	130	170	120	155	135.83	21.54

Trees: Hardwood

Bldg	Damage Indicator	Expected Values						Mean	Std Dev
		1	2	3	4	5	6		
TH	1	60	70	60	40	50	80	60.00	14.14
	2	75	80	70	50	70	100	74.17	16.25
	3	85	140	80	75	60	125	94.17	31.21
	4	85	120	90	90	100	155	106.67	26.77
	5	120	140	100	150	160	190	143.33	31.41

Trees: Softwood

Bldg	Damage Indicator	Expected Values						Mean	Std Dev
		1	2	3	4	5	6		
TS	1	60	70	70	40	50	70	60.00	12.65
	2	70	90	80	50	70	90	75.00	15.17
	3	75	130	80	75	60	110	88.33	26.20
	4	75	120	90	100	100	130	102.50	19.94
	5	100	130	100	140	160	155	130.83	26.16

Appendix C

FUJITA-SCALE RATINGS OF DODs BY NWS PERSONNEL

1. Small Barns and Farm Outbuildings (SBO)		Expert F-Scale						Median 3-sec Gust Speed						F Scale	EF Scale
DOD*	Damage description	1	2	3	4	5	6	1	2	3	4	5	6	Mean	Mean
1	No visible damage	0	0	0	0	0	0	61.25	61.25	61.25	61.25	61.25	61.25	61	62
2	Loss of wood or metal roof panels	0	0	0	0	0	0	61.25	61.25	61.25	61.25	61.25	61.25	61	74
7	Overturning or sliding of entire structure	0	0	1	1	1	1	61.25	61.25	98.20	98.20	98.20	98.20	86	99
5	Uplift or collapse of roof structure	0	0	1	1	1	1	61.25	61.25	98.20	98.20	98.20	98.20	86	93
3	Collapse of doors	0	0	0	1	0	1	61.25	61.25	61.25	98.20	61.25	98.20	74	83
6	Collapse of walls	0	0	1	1	0	2	61.25	61.25	98.20	98.20	61.25	139.60	87	97
4	Major loss of roof panels	0	1	1	1	0	2	61.25	98.20	98.20	98.20	61.25	139.60	93	90
8	Total destruction of building	1	1	2	2	1	2	98.20	98.20	139.60	139.60	98.20	139.60	119	112

2. One and Two Family Residences (FR12) **		Expert F-Scale						Median 3-sec Gust Speed						F Scale	EF Scale
DOD	Damage description	1	2	3	4	5	6	1	2	3	4	5	6	Mean	Mean
1	Threshold of visible damage	0	0	0	0	0	0	61.25	61.25	61.25	61.25	61.25	61.25	61	65
2	Loss of roofing material (< 20%), gutters and/or awning; loss of vinyl or metal siding	0	1	0	1	0	0	61.25	98.20	61.25	98.20	61.25	61.25	74	79
10	Total destruction of entire building	4	4	4	4	4	4	235.60	235.60	235.60	235.60	235.60	235.60	236	170
3	Broken glass in doors or windows	2	1	0	2	0	1	139.60	98.20	61.25	139.60	61.25	98.20	100	96
5	Entire house shifts off foundation	3	2	2	3	2	2	185.25	139.60	139.60	185.25	139.60	139.60	155	121
4	Uplift of roof deck and loss of significant roof covering material (>20%);collapse of chimney; garage doors collapse inward or outward; damage to porch or carport	1	1	1	2	1	1	98.20	98.20	98.20	139.60	98.20	98.20	105	97
6	Large sections of roof structure removed; most walls remain standing	2	2	2	2	2	2	139.60	139.60	139.60	139.60	139.60	139.60	140	122
9	Most walls collapsed in bottom floor, except at small interior rooms	3	3	4	3	3	4	185.25	185.25	235.60	185.25	185.25	235.60	202	152
7	Top floor exterior walls collapsed	3	3	4	3	3	3	185.25	185.25	235.60	185.25	185.25	185.25	194	132
10	Most interior walls of top story collapsed	2	3	3	3	3	3	139.60	185.25	185.25	185.25	185.25	185.25	178	148

* Numbers correspond to DODs in Appendix A ** DOD 8, 9, 10 are updated in Revision 2

3. Manufactured Homes Single Wide (MHSW)

DOD	Damage description	1	2	3	4	5	6	1.00	2.00	3.00	4.00	5.00	6.00	Mean	Mean
1	No visible damage	0	0	0	0	0	0	61.25	61.25	61.25	61.25	61.25	61.25	61	61
2	Loss of shingles or partial uplift of one-piece metal roof covering	0	0	1	0	0	0	61.25	61.25	98.20	61.25	61.25	61.25	67	74
5	Unit rolls on its side or upside down; essentially intact	1	0	1	1	0	1	98.20	61.25	98.20	98.20	61.25	98.20	86	98
3	Unit slides off masonry block piers but remains upright	1	0	1	1	0	0	98.20	61.25	98.20	98.20	61.25	61.25	80	87
6	Destruction of roof and walls leaving floor and undercarriage in place	2	1	1	2	0	1	139.60	98.20	98.20	139.60	61.25	98.20	106	105
4	Complete uplift of roof, most walls remain upright	1	0	1	1	0	1	98.20	61.25	98.20	98.20	61.25	98.20	86	89
7	Unit rolls, displaces or vaults; roof and walls separate from floor and undercarriage	1	1	2	2	1	1	98.20	98.20	139.60	139.60	98.20	98.20	112	109
8	Undercarriage separated from unit; rolls, tumbles and is badly bent	1	1	2	2	1	2	98.20	98.20	139.60	139.60	98.20	139.60	119	118
9	Complete destruction of unit; debris blown away	2	2	2	2	2	2	139.60	139.60	139.60	139.60	139.60	139.60	140	127

4. Manufactured Homes Double Wide (MHDW)

DOD	Damage description	1	2	3	4	5	6	1	2	3	4	5	6	Mean	Mean
1	No visible damage	0	0	0	0	0	0	61.25	61.25	61.25	61.25	61.25	61.25	61	61
2	Loss of shingles or other roofing material (<20%)	0	1	1	0	0	0	61.25	98.20	98.20	61.25	61.25	61.25	74	76
4	Broken windows	1	0	1	1	0	0	98.20	61.25	98.20	98.20	61.25	61.25	80	83
6	Complete uplift of roof; most walls remain standing	1	1	1	1	0	0	98.20	98.20	98.20	98.20	61.25	61.25	86	93
3	Damaged porch or carport	0	0	1	1	0	0	61.25	61.25	98.20	98.20	61.25	61.25	74	78
5	Uplift of roof deck and loss of significant roof covering material (>20%)	1	1	2	1	0	1	98.20	98.20	139.60	98.20	61.25	98.20	99	88
9	Complete destruction of roof and walls leaving floor and undercarriage in place	2	2	2	1	1	1	139.60	139.60	139.60	98.20	98.20	98.20	119	113
7	Unit slides off CMU block piers	1	1	1	1	1	1	98.20	98.20	98.20	98.20	98.20	98.20	98	94
8	Removal of entire roof structure leaving most walls standing	1	1	2	1	1	1	98.20	98.20	139.60	98.20	98.20	98.20	105	97
10	Unit rolls, displaces or vaults	2	2	2	2	1	1	139.60	139.60	139.60	139.60	98.20	98.20	126	114
11	Undercarriage separates from floor; rolls and tumbles, badly bent	2	3	2	2	1	2	139.60	185.25	139.60	139.60	98.20	139.60	140	127
12	Complete destruction of unit; debris blown away	3	3	2	2	2	2	185.25	185.25	139.60	139.60	139.60	139.60	155	134

5. Apartments, Condominiums & Townhouses (ACT)

DOD	Damage description	1	2	3	4	5	6	1	2	3	4	5	6	Mean	Mean
1	No visible damage	0	0	0	0	0	0	61.25	61.25	61.25	61.25	61.25	61.25	61	76
2	Loss of roof covering (<20%)	0	1	1	1	0	0	61.25	98.20	98.20	98.20	61.25	61.25	80	99
3	Uplift of roof decking; significant loss of roof covering (>20%)	1	2	2	1	0	1	98.20	139.60	139.60	98.20	61.25	98.20	106	124
4	Uplift or collapse of roof structure leaving most walls standing	2	2	2	2	1	2	139.60	139.60	139.60	139.60	98.20	139.60	133	138
5	Most top floor walls collapsed	3	2	3	3	2	2	185.25	139.60	185.25	185.25	139.60	139.60	162	158
6	Almost total destruction of top two floors	3	3	3	3	3	3	185.25	185.25	185.25	185.25	185.25	185.25	185	180
7	Total destruction of entire building	4	4	4.5	4	4	4	235.60	235.60	262.72	235.60	235.60	235.60	240	206

6. Motels (M)

DOD	Damage description	1	2	3	4	5	6	1	2	3	4	5	6	Mean	Mean
1	No visible damage	0	0	0	0	0	0	61.25	61.25	61.25	61.25	61.25	61.25	61	66
2	Loss of roof covering (<20%)	0	1	1	1	0	0	61.25	98.20	98.20	98.20	61.25	61.25	80	80
5	Uplift or collapse of canopy over driveway	1	1	1	1	0	0	98.20	98.20	98.20	98.20	61.25	61.25	86	99
3	Broken windows or patio doors	1	0	1	1	0	0	98.20	61.25	98.20	98.20	61.25	61.25	80	89
7	Top floor exterior walls collapsed	3	2	3	2	2	2	185.25	139.60	185.25	139.60	139.60	139.60	155	138
4	Uplift of roof deck; significant loss of roof covering (>20%); loss of EIFS wall covering	1	1	2	1	0	1	98.20	98.20	139.60	98.20	61.25	98.20	99	95
6	Uplift or collapse of roof structure leaving most walls standing	2	1	3	1	1	2	139.60	98.20	185.25	98.20	98.20	139.60	127	123
8	All top floor walls collapsed	3	2	3	3	2	3	185.25	139.60	185.25	185.25	139.60	185.25	170	143
9	Collapse of top two floors of three or more story building	4	3	4	3	2	4	235.60	185.25	235.60	185.25	139.60	235.60	203	170
10	Total destruction of entire building	5	3	5	4	3	5	289.85	185.25	289.85	235.60	185.25	289.85	246	190

7. Masonry Apartments or Motels (MAM)

DOD	Damage description	1	2	3	4	5	6	1	2	3	4	5	6	Mean	Mean
1	No visible damage	0	0	0	0	0	0	61.25	61.25	61.25	61.25	61.25	61.25	61	65
2	Loss of roof covering (<20%)	0	1	1	1	0	0	61.25	98.20	98.20	98.20	61.25	61.25	80	80
3	Uplift of lightweight metal roof decking	1	2	1	1	0	0	98.20	139.60	98.20	98.20	61.25	61.25	93	95
4	Uplift of pre-cast concrete roof decking	3	2	3	1	1	1	185.25	139.60	185.25	98.20	98.20	98.20	134	121
5	Collapse of top story walls	3	2	3	2	2	2	185.25	139.60	185.25	139.60	139.60	139.60	155	133
6	Collapse of top two floors of three or more stories	4	3	4	2	3	3	235.60	185.25	235.60	139.60	185.25	185.25	194	156
7	Total destruction of building	5	4	5	3	4	5	289.85	235.60	289.85	185.25	235.60	289.85	254	180

8. Small Retail Building (SRB)

DOD	Damage description	1	2	3	4	5	6	1	2	3	4	5	6	Mean	Mean
1	No visible damage	0	0	0	0	0	0	61.25	61.25	61.25	61.25	61.25	61.25	61	65
2	Loss of roof covering (20%)	0	1	1	1	0	0	61.25	98.20	98.20	98.20	61.25	61.25	80	78
3	Broken windows and glass doors	1	0	1	1	0	0	98.20	61.25	98.20	98.20	61.25	61.25	80	86
4	Uplift of roof deck; significant loss of roof covering (20%)	1	1	2	2	0	1	98.20	98.20	139.60	139.60	61.25	98.20	106	98
5	Canopies or covered walkways destroyed	1	1	1	1	0	0	98.20	98.20	98.20	98.20	61.25	61.25	86	98
6	Uplift or collapse of entire roof structure	2	1	2	2	1	2	139.60	98.20	139.60	139.60	98.20	139.60	126	119
7	Collapse of exterior walls; closely spaced interior walls remain standing	3	2	3	2	2	3	185.25	139.60	185.25	139.60	139.60	185.25	162	138
8	Total destruction of entire building	4	3	4.5	3	3	4.5	235.60	185.25	262.72	185.25	185.25	262.72	219	167

9. Small Professional Building (SPB)

DOD	Damage description	1	2	3	4	5	6	1	2	3	4	5	6	Mean	Mean
1	No visible damage	0	0	0	0	0	0	61.25	61.25	61.25	61.25	61.25	61.25	61	65
2	Loss of roof covering (20%)	0	1	1	1	0	0	61.25	98.20	98.20	98.20	61.25	61.25	80	78
4	Exterior doors fail	1	1	1	1	0	0	98.20	98.20	98.20	98.20	61.25	61.25	86	100
3	Broken windows, including clearstory windows or skylights	1	0	1	1	0	0	98.20	61.25	98.20	98.20	61.25	61.25	80	89
6	Collapsed facade or parapet walls	1	1	1	1	0	0	98.20	98.20	98.20	98.20	61.25	61.25	86	103
5	Uplift of some roof deck; significant loss of roof covering (20%); loss of rooftop HVAC equipment	1	1	2	2	1	1	98.20	98.20	139.60	139.60	98.20	98.20	112	100
7	Uplift or collapse of entire roof structure	2	2	2	2	1	2	139.60	139.60	139.60	139.60	98.20	139.60	133	124
8	Collapse of exterior walls; closely spaced interior walls remain standing	3	3	3	2	2	3	185.25	185.25	185.25	139.60	139.60	185.25	170	144
9	Total destruction of entire building	4	4	4	3	3	4.5	235.60	235.60	235.60	185.25	185.25	262.72	223	157

10. Strip Mall (SM)

DOD	Damage description	1	2	3	4	5	6	1	2	3	4	5	6	Mean	Mean
1	No visible damage	0	0	0	0	0	0	61.25	61.25	61.25	61.25	61.25	61.25	61	65
2	Uplift of roof covering at eaves and roof corners (20%)	0	1	1	1	0	0	61.25	98.20	98.20	98.20	61.25	61.25	80	80
4	Uplift of roof decking	1	0	1	1	0	1	98.20	61.25	98.20	98.20	61.25	98.20	86	101
3	Broken windows and door glass	1	0	1	1	0	0	98.20	61.25	98.20	98.20	61.25	61.25	80	88
5	Collapsed façade or parapet walls	1	1	1	2	1	0	98.20	98.20	98.20	139.60	98.20	61.25	99	103
6	Covered walkways uplifted or collapsed	1	1	1	1	0	0	98.20	98.20	98.20	98.20	61.25	61.25	86	103
7	Uplift or collapse of roof structure	2	2	2	2	1	1	139.60	139.60	139.60	139.60	98.20	98.20	126	122
8	Exterior unreinforced masonry walls collapse	3	1	2	2	2	1	185.25	98.20	139.60	139.60	139.60	98.20	133	140
9	Total destruction of entire building	4	3	3	3	3	3	235.60	185.25	185.25	185.25	185.25	185.25	194	171

11. Large Shopping Mall (LSM)

DOD	Damage description	1	2	3	4	5	6	1	2	3	4	5	6	Mean	Mean
1	No visible damage	0	0	0	0	0	0	61.25	61.25	61.25	61.25	61.25	61.25	61	71
2	Loss of roof covering (20%)	0	1	1	1	0	0	61.25	98.20	98.20	98.20	61.25	61.25	80	85
8	Interior walls of top story collapsed	2	2	1	2	1	4	139.60	139.60	98.20	139.60	98.20	235.60	142	160
3	Broken skylights, clearstory windows and atrium walls	1	1	1	1	0	0	98.20	98.20	98.20	98.20	61.25	61.25	86	92
4	Uplift of some roof decking; significant loss of roofing material (20%); loss of rooftop HVAC equipment	1	1	2	2	1	1	98.20	98.20	139.60	139.60	98.20	98.20	112	108
5	Wall cladding stripped starting at corners and progressing to other areas	1	1	1	2	1	1	98.20	98.20	98.20	139.60	98.20	98.20	105	111
6	Roof structure uplifted or collapsed	2	1	2	2	2	2	139.60	98.20	139.60	139.60	139.60	139.60	133	128
7	Exterior walls in top story collapsed	3	2	3	2	3	3	185.25	139.60	185.25	139.60	185.25	185.25	170	144
9	Complete destruction of all or a large section of the building	4	3	4	3	3	5	235.60	185.25	235.60	185.25	185.25	289.85	219	204

12. Large Isolated Retail Building (LIRB)

DOD	Damage description	1	2	3	4	5	6	1	2	3	4	5	6	Mean	Mean
1	No visible damage	0	0	0	0	0	0	61.25	61.25	61.25	61.25	61.25	61.25	61	68
2	Loss of roofing material (20%)	0	1	1	1	0	0	61.25	98.20	98.20	98.20	61.25	61.25	80	81
3	Uplift of some roof decking; significant loss of roofing material (>20%); loss of rooftop HVAC equipment	1	1	2	2	1	1	98.20	98.20	139.60	139.60	98.20	98.20	112	103
4	Long roof spans collapse downward	2	1	2	2	1	2	139.60	98.20	139.60	139.60	98.20	139.60	126	122
5	Uplift and removal of roof structure	2	2	3	3	2	3	139.60	139.60	185.25	185.25	139.60	185.25	162	134
6	Inward or outward collapse of exterior walls	3	2	3	3	3	4	185.25	139.60	185.25	185.25	185.25	235.60	186	137
7	Complete destruction of all or a large part of the building	4	3	4	5	4	5	235.60	185.25	235.60	289.85	235.60	289.85	245	173

13. Automobile Showroom (ASR)

DOD	Damage description	1	2	3	4	5	6	1	2	3	4	5	6	Mean	Mean
1	No visible damage	0	0	0	0	0	0	61.25	61.25	61.25	61.25	61.25	61.25	61	65
2	Loss of roofing material (20%)	0	1	1	1	0	0	61.25	98.20	98.20	98.20	61.25	61.25	80	80
4	Uplift of some roof decking; significant loss of roofing material (>20%); loss of rooftop HVAC equipment	1	1	2	2	0	1	98.20	98.20	139.60	139.60	61.25	98.20	106	101
3	Broken windows or glass doors	0	0	1	1	0	0	61.25	61.25	98.20	98.20	61.25	61.25	74	87
6	Uplift or collapse of roof structure	1	1	2	2	1	1	98.20	98.20	139.60	139.60	98.20	98.20	112	118
5	Cladding stripped off walls	1	1	1	2	0	1	98.20	98.20	98.20	139.60	61.25	98.20	99	112
7	Exterior walls collapsed	2	2	2	2	2	2	139.60	139.60	139.60	139.60	139.60	139.60	140	126
8	Complete destruction of all or a large section of the building	3	3	3	3	3	4	185.25	185.25	185.25	185.25	185.25	235.60	194	157

14. Automobile Service Building (ASB)

DOD	Damage description	1	2	3	4	5	6	1	2	3	4	5	6	Mean	Mean
1	No visible damage	0	0	0	0	0	0	61.25	61.25	61.25	61.25	61.25	61.25	61	63
2	Loss of some roofing material (20%)	0	0	1	0	0	0	61.25	61.25	98.20	61.25	61.25	61.25	67	78
4	Uplift of metal roof decking; significant loss of roof covering (>20%); loss of rooftop HVAC equipment	1	1	2	1	0	1	98.20	98.20	139.60	98.20	61.25	98.20	99	98
3	Failure of overhead doors	1	1	1	1	1	1	98.20	98.20	98.20	98.20	98.20	98.20	98	91
6	Uplift or collapse of roof structure	1	1	2	1	1	2	98.20	98.20	139.60	98.20	98.20	139.60	112	121
5	Collapse of non-bearing masonry or tilt-up walls	2	1	2	2	1	2	139.60	98.20	139.60	139.60	98.20	139.60	126	114
7	Collapse of load-bearing walls	3	2	3	3	2	3	185.25	139.60	185.25	185.25	139.60	185.25	170	128
8	Complete destruction of all or a large section of the building	3	3	3	3	3	4	185.25	185.25	185.25	185.25	185.25	235.60	194	157

15. Elementary School (ES)

DOD	Damage description	1	2	3	4	5	6	1	2	3	4	5	6	Mean	Mean
1	No visible damage	0	0	0	0	0	0	61.25	61.25	61.25	61.25	61.25	61.25	61	65
2	Loss of roofing material (20%)	0	1	1	0	0	0	61.25	98.20	98.20	61.25	61.25	61.25	74	79
5	Uplift of metal roof decking; significant loss of roof covering (>20%); loss of rooftop HVAC equipment	1	1	2	1	0	1	98.20	98.20	139.60	98.20	61.25	98.20	99	101
6	Damage to or loss of wall cladding	1	1	1	1	0	1	98.20	98.20	98.20	98.20	61.25	98.20	92	108
3	Broken windows	1	0	1	1	0	0	98.20	61.25	98.20	98.20	61.25	61.25	80	87
4	Exterior doors fail	2	1	1	2	0	0	139.60	98.20	98.20	139.60	61.25	61.25	100	99
7	Uplift or collapse of roof structure	2	2	2	2	1	2	139.60	139.60	139.60	139.60	98.20	139.60	133	125
9	Collapse of bearing walls	3	2	3	4	2	4	185.25	139.60	185.25	235.60	139.60	235.60	187	139
8	Collapse of non-bearing exterior walls	3	3	2	3	3	3	185.25	185.25	139.60	185.25	185.25	185.25	178	153
10	Complete destruction of all or a large section of the building	4	4	4	4	4	5	235.60	235.60	235.60	235.60	235.60	289.85	245	176

16. Junior or Senior High School (JHSH)

DOD	Damage description	1	2	3	4	5	6	1	2	3	4	5	6	Mean	Mean
1	No visible damage	0	0	0	0	0	0	61.25	61.25	61.25	61.25	61.25	61.25	61	68
2	Loss of roof covering (20%)	0	1	1	0	0	0	61.25	98.20	98.20	61.25	61.25	61.25	74	79
5	Uplift of metal roof decking; significant loss of roof covering (>20%); loss of rooftop HVAC equipment	1	1	2	1	0	1	98.20	98.20	139.60	98.20	61.25	98.20	99	101
3	Broken windows	1	0	1	1	0	0	98.20	61.25	98.20	98.20	61.25	61.25	80	87
6	Damage to or loss of wall cladding	1	1	1	1	0	1	98.20	98.20	98.20	98.20	61.25	98.20	92	108
4	Exterior door failures	2	1	1	2	0	0	139.60	98.20	98.20	139.60	61.25	61.25	100	101
7	Collapse of tall masonry walls at gym, cafeteria or auditorium	2	1	2	2	1	1	139.60	98.20	139.60	139.60	98.20	98.20	119	114
8	Uplift or collapse of roof structure	2	2	2	2	2	2	139.60	139.60	139.60	139.60	139.60	139.60	140	125
9	Collapse of exterior walls in top floor	3	2	3	3	2	3	185.25	139.60	185.25	185.25	139.60	185.25	170	139
10	Top floor destroyed	4	3	3	3	3	4	235.60	185.25	185.25	185.25	185.25	235.60	202	158
11	Complete destruction of all or a large section of the building	5	4	4	4	4	5	289.85	235.60	235.60	235.60	235.60	289.85	254	192

17. Low-Rise Building (LRB)

DOD	Damage description	1	2	3	4	5	6	1	2	3	4	5	6	Mean	Mean
1	No visible damage	0	0	0	0	0	0	61.25	61.25	61.25	61.25	61.25	61.25	61	68
2	Loss of roofing material (20%)	0	1	1	0	0	1	61.25	98.20	98.20	61.25	61.25	98.20	80	80
3	Uplift of metal roof deck at eaves and roof corners; significant loss of roofing material (>20%)	1	1	2	1	0	2	98.20	98.20	139.60	98.20	61.25	139.60	106	101
4	Broken windows; glass in entryways; significant damage to building interior	1	2	1	2	0	0	98.20	139.60	98.20	139.60	61.25	61.25	100	101
5	Uplift or collapse of roof structure	2	2	2	2	1	3	139.60	139.60	139.60	139.60	98.20	185.25	140	133
6	Failure of exterior walls at top floor	2	3	3	3	2	4	139.60	185.25	185.25	185.25	139.60	235.60	178	143
7	Significant structural deformation or collapse of building	3	4	5	4	4	5	185.25	235.60	289.85	235.60	235.60	289.85	245	188

18. Mid-Rise Building (MRB)

DOD	Damage description	1	2	3	4	5	6	1	2	3	4	5	6	Mean	Mean
1	No visible damage	0	0	0	0	0	0	61.25	61.25	61.25	61.25	61.25	61.25	61	70
3	Damage to penthouse roof and/or walls; loss of rooftop HVAC equipment	1	1	2	1	0	0	98.20	98.20	139.60	98.20	61.25	61.25	93	92
2	Loss of roofing covering (20%)	0	1	1	0	0	1	61.25	98.20	98.20	61.25	61.25	98.20	80	83
4	Damage to parapet wall or coping	1	1	1	1	0	1	98.20	98.20	98.20	98.20	61.25	98.20	92	99
6	Uplift of roof decking; significant loss of roofing material (>20%)	1	2	2	1	1	2	98.20	139.60	139.60	98.20	98.20	139.60	119	119
5	Broken glass in curtain walls; glass in entryways; significant damage to building interior	1	2	2	2	1	0	98.20	139.60	139.60	139.60	98.20	61.25	113	101
7	Broken curtain wall panel anchors	2	2	2	2	1	2	139.60	139.60	139.60	139.60	98.20	139.60	133	129
8	Uplift or collapse of roof structure	2	3	2	2	2	3	139.60	185.25	139.60	139.60	139.60	185.25	155	136
9	Failure of exterior walls at top story	3	3	3	3	3	4	185.25	185.25	185.25	185.25	185.25	235.60	194	145
10	Significant structural deformation or collapse of building	3	5	5	4	4	5	185.25	289.85	289.85	235.60	235.60	289.85	254	210

19. High-Rise Building (HRB)

DOD	Damage description	1	2	3	4	5	6	1	2	3	4	5	6	Mean	Mean
1	No visible damage	0	0	0	0	0	0	61.25	61.25	61.25	61.25	61.25	61.25	61	70
3	Damage to penthouse roof and/or walls; loss of rooftop HVAC equipment	1	1	2	1	1	0	98.20	98.20	139.60	98.20	98.20	61.25	99	93
2	Loss of roof covering (<20%)	0	1	1	0	0	1	61.25	98.20	98.20	61.25	61.25	98.20	80	86
6	Broken curtain wall panel anchors	1	2	2	2	0	2	98.20	139.60	139.60	139.60	61.25	139.60	120	129
4	Broken glass in curtain walls; glass in entryways; significant damage to building interior	1	2	2	2	0	0	98.20	139.60	139.60	139.60	61.25	61.25	107	101
7	Uplift of roof decking; significant loss of roofing material (>20%)	1	2	2	1	2	2	98.20	139.60	139.60	98.20	139.60	139.60	126	143
5	Damage to parapet wall or coping	1	1	1	2	1	2	98.20	98.20	98.20	139.60	98.20	139.60	112	104
9	Uplift or collapse of roof structure	2	3	2	2	3	3	139.60	185.25	139.60	139.60	185.25	185.25	162	159
8	Failure of exterior walls at top story	2	3	3	3	4	4	139.60	185.25	185.25	185.25	235.60	235.60	194	145
10	Significant structural deformation or collapse of building	3	5	5	4	5	5	185.25	289.85	289.85	235.60	289.85	289.85	263	226

20. Institutional Building (IB)

DOD	Damage description	1	2	3	4	5	6	1	2	3	4	5	6	Mean	Mean
1	No visible damage	0	0	0	0	0	0	61.25	61.25	61.25	61.25	61.25	61.25	61	72
3	Damage to penthouse roof and walls; loss of rooftop HVAC equipment	1	1	1	2	0	0	98.20	98.20	98.20	139.60	61.25	61.25	93	92
2	Loss of roof covering (<20%)	0	1	1	2	0	1	61.25	98.20	98.20	139.60	61.25	98.20	93	86
6	Façade components ripped from structure	1	1	2	2	0	1	98.20	98.20	139.60	139.60	61.25	98.20	106	118
4	Broken windows or glass doors	1	0	1	1	0	0	98.20	61.25	98.20	98.20	61.25	61.25	80	95
5	Uplift of lightweight roof deck and insulation; significant loss of roofing material (>20%)	1	1	2	3	1	2	98.20	98.20	139.60	185.25	98.20	139.60	127	114
9	Uplift of metal deck with concrete fill slab	2	2	3	3	2	3	139.60	139.60	185.25	185.25	139.60	185.25	162	146
8	Uplift of pre-cast concrete roof slabs	3	2	4	3	2	3	185.25	139.60	235.60	185.25	139.60	185.25	178	142
7	Curtain walls and other wall cladding damaged	3	2	2	3	2	2	185.25	139.60	139.60	185.25	139.60	139.60	155	131
10	Collapse of top story exterior walls	3	3	3	4	3	4	185.25	185.25	185.25	235.60	185.25	235.60	202	148
11	Significant structural deformation or collapse of structure	5	5	5	5	5	5	289.85	289.85	289.85	289.85	289.85	289.85	290	210

21. Metal Building Systems (MBS)

DOD	Damage description	1	2	3	4	5	6	1	2	3	4	5	6	Mean	Mean
1	No visible damage	0	0	0	0	0	0	61.25	61.25	61.25	61.25	61.25	61.25	61	67
2	Inward or outward collapse of overhead doors	1	1	1	1	0	0	98.20	98.20	98.20	98.20	61.25	61.25	86	89
3	Metal wall and roof panels pulled off of the structure	2	1	1	2	1	1	139.60	98.20	98.20	139.60	98.20	98.20	112	95
5	Buckling of purlin	2	1	2	2	1	1	139.60	98.20	139.60	139.60	98.20	98.20	119	118
4	Column anchorage failed	2	2	2	3	1	2	139.60	139.60	139.60	185.25	98.20	139.60	140	117
6	Failure of x-braces in lateral load resisting system	2	2	2	3	2	2	139.60	139.60	139.60	185.25	139.60	139.60	147	138
7	Progressive collapse of rigid frames	2	2	3	3	2	2	139.60	139.60	185.25	185.25	139.60	139.60	155	143
8	Total destruction of building	3	3	3	4	3	3	185.25	185.25	185.25	235.60	185.25	185.25	194	155

22. Service Station Canopy (SSC)

DOD	Damage description	1	2	3	4	5	6	1	2	3	4	5	6	Mean	Mean
1	No visible damage	*												44	63
2	Facia material blown from canopy													61	78
3	Metal roof panels stripped from canopy													85	92
4	Columns bend or buckle													55	109
5	Canopy collapsed due to column foundation failure													92	114
6	Complete destruction of canopy													79	133

*Expert's values not available

23. Warehouse Building (WHB)

DOD	Damage description	1	2	3	4	5	6	1	2	3	4	5	6	Mean	Mean
1	No visible damage	0	0	0	0	0	0	61.25	61.25	61.25	61.25	61.25	61.25	61	68
2	Loss of roofing material (<20%)	0	1	1	0	0	0	61.25	98.20	98.20	61.25	61.25	61.25	74	83
4	Uplift of roof deck; significant loss of roofing material (>20%); loss of rooftop HVAC equipment	1	1	2	1	0	1	98.20	98.20	139.60	98.20	61.25	98.20	99	103
3	Inward or outward collapse of overhead doors	1	1	1	1	0	1	98.20	98.20	98.20	98.20	61.25	98.20	92	88
6	Collapse of pre-cast concrete tilt-up walls	2	2	3	2	1	2	139.60	139.60	185.25	139.60	98.20	139.60	140	124
5	Collapse of other non-bearing exterior walls	2	2	3	3	1	2	139.60	139.60	185.25	185.25	98.20	139.60	148	114
7	Total destruction of a large section of building or entire building	2	3	4	4	2	3	139.60	185.25	235.60	235.60	139.60	185.25	187	158

24. Electrical Transmission Line (ETL)

DOD	Damage description	1	2	3	4	5	6	1	2	3	4	5	6	Mean	Mean
1	No visible damage	0	0	0	0	0	0	61.25	61.25	61.25	61.25	61.25	61.25	61	83
2	Broken wood cross arms	1	1	1	1	0	0	98.20	98.20	98.20	98.20	61.25	61.25	86	99
3	Wood poles leaning but not broken	1	1	1	1	0	0	98.20	98.20	98.20	98.20	61.25	61.25	86	108
4	Broken wood poles	2	2	2	2	1	1	139.60	139.60	139.60	139.60	98.20	98.20	126	118
5	Bent or broken steel or concrete poles	2	3	3	2	2	2	139.60	185.25	185.25	139.60	139.60	139.60	155	138
6	Collapsed metal trussed towers	2	3	3	2	2	2	139.60	185.25	185.25	139.60	139.60	139.60	155	141

25. Free Standing Towers (FST)

DOD	Damage description	1	2	3	4	5	6	1	2	3	4	5	6	Mean	Mean
1	No visible damage	0	0	0	0	0	0	61.25	61.25	61.25	61.25	61.25	61.25	61	92
2	Collapsed cell phone tower	2	2	2	2	2	2	139.60	139.60	139.60	139.60	139.60	139.60	140	133
3	Collapsed microwave tower	2	3	3	2	2	2	139.60	185.25	185.25	139.60	139.60	139.60	155	136

26. Free Standing Light Poles, Luminary Pole, Flag Poles (FSP)

DOD	Damage description	1	2	3	4	5	6	1	2	3	4	5	6	Mean	Mean
1	No visible damage	0	0	0	0	0	0	61.25	61.25	61.25	61.25	61.25	61.25	61	81
2	Bent poles	1	1	1	1	1	1	98.20	98.20	98.20	98.20	98.20	98.20	98	102
3	Collapsed poles	1	2	2	1	2	2	98.20	139.60	139.60	98.20	139.60	139.60	126	118

27. Trees: Hardwood (TH)

DOD	Damage description	1	2	3	4	5	6	1	2	3	4	5	6	Mean	Mean
1	Small limbs broken	0	0	0	0	0	0	61.25	61.25	61.25	61.25	61.25	61.25	61	60
2	Large branches broken	0	1	1	0	0	0	61.25	98.20	98.20	61.25	61.25	61.25	74	74
3	Trunks snapped	2	2	2	2	1	1	139.60	139.60	139.60	139.60	98.20	98.20	126	91
4	Trees uprooted	1	2	1	2	1	2	98.20	139.60	98.20	139.60	98.20	139.60	119	110
5	Trees debarked with only stubs of largest branches remaining	1	4	4	5	3	4	98.20	235.60	235.60	289.85	185.25	235.60	213	143

28. Trees: Softwood (TS)

DOD	Damage description	1	2	3	4	5	6	1	2	3	4	5	6	Mean	Mean
1	Small limbs broken	0	0	0	0	0	0	61.25	61.25	61.25	61.25	61.25	61.25	61	60
2	Large branches broken	0	1	1	0	0	0	61.25	98.20	98.20	61.25	61.25	61.25	74	74
4	Trunks snapped	1	2	1	2	1	1	98.20	139.60	98.20	139.60	98.20	98.20	112	110
3	Trees uprooted	1	2	1	1	1	2	98.20	139.60	98.20	98.20	98.20	139.60	112	91
5	Trees debarked with only stubs of largest branches remaining	1	4	4	5	3	3	98.20	235.60	235.60	289.85	185.25	185.25	205	143

BEFORE THE PUBLIC UTILITY COMMISSION
OF OREGON

Docket PCN 5

In the Matter of

IDAHO POWER COMPANY'S
PETITION FOR CERTIFICATE OF PUBLIC CONVENIENCE
AND NECESSITY

Surrebuttal Testimony of Joseph Stippel

Exhibit 1905

National Oceanic and Atmospheric Administration Storm Events Database –
Tornadoes in Oregon from 01/01/1950 to 12/31/2022

April 7, 2023

Storm Events Database

Search Results for All Counties in Oregon

Event Types: **Tornado**

126 events were reported between 01/01/1950 and 12/31/2022 (26663 days)

Summary Info:

Number of County/Zone areas affected:	31
Number of Days with Event:	110
Number of Days with Event and Death:	0
Number of Days with Event and Death or Injury:	4
Number of Days with Event and Property Damage:	65
Number of Days with Event and Crop Damage:	4
Number of Event Types reported:	1

Column Definitions:

'Mag': Magnitude, 'Dth': Deaths, 'Inj': Injuries, 'PrD': Property Damage, 'CrD': Crop Damage

Click on **Location** below to display details.

Available Event Types have changed over time. Please refer to the [Database Details](#) for more information.

Select:

Sort By:

<u>Location</u>	<u>County/Zone</u>	<u>St.</u>	<u>Date</u>	<u>Time</u>	<u>T.Z.</u>	<u>Type</u>	<u>Mag.</u>	<u>Dth</u>	<u>Inj</u>	<u>PrD</u>	<u>CrD</u>
Totals:								0	5	32.466M	125.00K
LANE CO.	LANE CO.	OR	12/06/1951	17:40	CST	Tornado	F1	0	0	0.03K	0.00K
WASHINGTON CO.	WASHINGTON CO.	OR	10/22/1954	17:35	CST	Tornado	F0	0	0	0.00K	0.00K
CLACKAMAS CO.	CLACKAMAS CO.	OR	04/12/1957	14:00	CST	Tornado	F1	0	0	2.50K	0.00K
GILLIAM CO.	GILLIAM CO.	OR	04/12/1957	14:30	CST	Tornado	F0	0	0	2.50K	0.00K
MARION CO.	MARION CO.	OR	03/08/1960	17:15	CST	Tornado	F1	0	0	2.50K	0.00K
KLAMATH CO.	KLAMATH CO.	OR	05/19/1962	14:00	CST	Tornado	F1	0	0	2.50K	0.00K
COLUMBIA CO.	COLUMBIA CO.	OR	11/10/1965	16:55	CST	Tornado	F0	0	0	2.50K	0.00K
WASHINGTON CO.	WASHINGTON CO.	OR	06/23/1966	18:30	CST	Tornado	F0	0	0	2.50K	0.00K
MALHEUR CO.	MALHEUR CO.	OR	08/25/1966	22:10	CST	Tornado	F1	0	0	25.00K	0.00K
CLATSOP CO.	CLATSOP CO.	OR	10/20/1966	17:30	CST	Tornado	F0	0	0	25.00K	0.00K
MALHEUR CO.	MALHEUR CO.	OR	06/21/1967	15:00	CST	Tornado	F0	0	0	250.00K	0.00K
MALHEUR CO.	MALHEUR CO.	OR	06/21/1967	17:00	CST	Tornado	F0	0	0	0.00K	0.00K
CLATSOP CO.	CLATSOP CO.	OR	10/03/1967	15:05	CST	Tornado	F1	0	0	25.00K	0.00K
WALLOWA CO.	WALLOWA CO.	OR	06/11/1968	18:00	CST	Tornado	F2	0	0	25.000M	0.00K
WASHINGTON CO.	WASHINGTON CO.	OR	10/13/1968	15:00	CST	Tornado	F0	0	0	0.00K	0.00K
WALLOWA CO.	WALLOWA CO.	OR	06/23/1969	18:00	CST	Tornado	F1	0	0	25.00K	0.00K
WASCO CO.	WASCO CO.	OR	05/11/1970	16:15	CST	Tornado	F0	0	0	0.00K	0.00K
YAMHILL CO.	YAMHILL CO.	OR	05/25/1971	17:55	CST	Tornado	F0	0	0	2.50K	0.00K
MULTNOMAH CO.	MULTNOMAH CO.	OR	04/05/1972	14:50	CST	Tornado	F3	0	0	250.00K	0.00K
LAKE CO.	LAKE CO.	OR	09/21/1973	12:23	CST	Tornado	F0	0	0	0.00K	0.00K
MALHEUR CO.	MALHEUR CO.	OR	04/23/1974	15:30	CST	Tornado	F1	0	0	25.00K	0.00K
LANE CO.	LANE CO.	OR	08/18/1975	16:00	CST	Tornado		0	0	0.00K	0.00K
BAKER CO.	BAKER CO.	OR	09/16/1975	15:30	CST	Tornado		0	0	0.00K	0.00K
TILLAMOOK CO.	TILLAMOOK CO.	OR	12/12/1975	23:20	CST	Tornado	F1	0	0	2.500M	0.00K
COLUMBIA CO.	COLUMBIA CO.	OR	08/16/1978	16:20	CST	Tornado	F1	0	0	25.00K	0.00K
CURRY CO.	CURRY CO.	OR	03/22/1983	17:25	CST	Tornado	F0	0	0	25.00K	0.00K
UNION CO.	UNION CO.	OR	06/21/1983	16:15	CST	Tornado	F0	0	0	2.50K	0.00K
DESCHUTES CO.	DESCHUTES CO.	OR	06/22/1983	13:25	CST	Tornado	F0	0	0	2.50K	0.00K

YAMHILL CO.	YAMHILL CO.	OR	04/18/1984	09:30	CST	Tomado	F0	0	0	2.50K	0.00K
LANE CO.	LANE CO.	OR	05/14/1984	15:00	CST	Tomado	F0	0	0	25.00K	0.00K
CLACKAMAS CO.	CLACKAMAS CO.	OR	10/26/1984	14:30	CST	Tomado	F0	0	0	25.00K	0.00K
LINCOLN CO.	LINCOLN CO.	OR	11/02/1984	19:00	CST	Tomado	F0	0	0	250.00K	0.00K
DESCHUTES CO.	DESCHUTES CO.	OR	08/22/1989	14:00	PST	Tomado	F1	0	0	25.00K	0.00K
LANE CO.	LANE CO.	OR	11/24/1989	16:30	PST	Tomado	F1	0	0	25.00K	0.00K
MULTNOMAH CO.	MULTNOMAH CO.	OR	04/09/1991	15:30	PST	Tomado	F0	0	0	0.25K	0.00K
UMATILLA CO.	UMATILLA CO.	OR	05/01/1991	18:40	CST	Tomado	F0	0	0	0.00K	0.00K
MULTNOMAH CO.	MULTNOMAH CO.	OR	11/12/1991	16:35	PST	Tomado	F1	0	0	25.00K	0.00K
WASHINGTON CO.	WASHINGTON CO.	OR	11/12/1991	17:00	PST	Tomado	F1	0	0	25.00K	0.00K
MARION CO.	MARION CO.	OR	11/12/1991	18:00	PST	Tomado	F0	0	0	25.00K	0.00K
WALLOWA CO.	WALLOWA CO.	OR	07/22/1992	17:30	PDT	Tomado	F0	0	0	2.50K	0.00K
YAMHILL AND WASHINGTON C...	YAMHILL AND WASHINGTON C...	OR	12/08/1993	14:00	PST	Tomado	F2	0	0	0.01K	0.00K
Warrenton	CLATSOP CO.	OR	02/13/1994	08:34	PST	Tomado	F0	0	0	0.50K	0.00K
Albany	LINN CO.	OR	03/22/1994	14:40	PST	Tomado	F0	0	0	0.50K	0.00K
Near Happy Valley	HARNEY CO.	OR	03/11/1995	16:45	PST	Tomado	F0	0	0	0.00K	0.00K
BAKER CO.	BAKER CO.	OR	05/11/1995	13:30	PST	Tomado	F0	0	0	0.00K	0.00K
KLAMATH CO.	KLAMATH CO.	OR	05/30/1995	15:30	PST	Tomado	F0	0	0	20.00K	0.00K
SE of Hermiston	UMATILLA CO.	OR	07/09/1995	12:45	PST	Tomado	F0	0	0	0.00K	0.00K
HALFWAY	BAKER CO.	OR	05/17/1996	17:00	PST	Tomado	F0	0	0	0.00K	0.00K
SEASIDE	CLATSOP CO.	OR	09/15/1996	17:21	PST	Tomado	F0	0	1	0.00K	0.00K
(JNW)NEWPORT ARPT	LINCOLN CO.	OR	10/24/1996	14:00	PST	Tomado	F0	0	0	0.00K	0.00K
EUGENE	LANE CO.	OR	12/05/1996	11:45	PST	Tomado	F0	0	0	50.00K	0.00K
HUNTINGTON	BAKER CO.	OR	04/30/1997	14:00	PST	Tomado	F0	0	0	0.00K	0.00K
ONTARIO ARPT	MALHEUR CO.	OR	04/30/1997	14:45	MST	Tomado	F1	0	0	0.00K	0.00K
KEIZER	MARION CO	OR	05/31/1997	10 10	PST	Tomado	F0	0	0	15 00K	0 00K
ALBANY	BENTON CO.	OR	06/01/1997	11:37	PST	Tomado	F0	0	0	0.00K	0.00K
ONTARIO	MALHEUR CO.	OR	06/17/1997	15:55	MST	Tomado	F0	0	0	0.00K	0.00K
TUMALO	DESCHUTES CO.	OR	09/03/1997	13:20	PST	Tomado	F0	0	0	0.00K	0.00K
RICKREALL	POLK CO.	OR	09/15/1997	10:30	PST	Tomado	F0	0	0	0.00K	1.00K
GARIBALDI	TILLAMOOK CO.	OR	09/15/1997	12:02	PST	Tomado	F0	0	0	40.00K	0.00K
MC COY	POLK CO.	OR	09/15/1997	12:40	PST	Tomado	F0	0	0	5.00K	0.00K
BURNS	HARNEY CO.	OR	09/15/1997	19:00	PST	Tomado	F0	0	0	15.00K	0.00K
TURNER	MARION CO.	OR	09/17/1997	10:35	PST	Tomado	F0	0	0	10.00K	0.00K
MACLEAY	MARION CO.	OR	09/17/1997	11:05	PST	Tomado	F0	0	0	0.00K	0.00K
PACIFIC CITY	TILLAMOOK CO.	OR	09/18/1997	08:15	PST	Tomado	F0	0	0	0.00K	0.00K
NESKOWIN	TILLAMOOK CO.	OR	09/18/1997	08:30	PST	Tomado	F0	0	0	0.00K	0.00K
SEASIDE	CLATSOP CO.	OR	01/05/1998	13:00	PST	Tomado	F0	0	0	3.00K	0.00K
SILVERTON	MARION CO.	OR	10/03/1998	14:30	PST	Tomado	F0	0	0	0.00K	0.00K
CANBY	CLACKAMAS CO.	OR	10/03/1998	15:45	PST	Tomado	F0	0	0	5.00K	0.00K
CRESWELL	LANE CO.	OR	12/02/1999	14:09	PST	Tomado	F0	0	1	10.50K	0.00K
ST HELENS	COLUMBIA CO.	OR	04/28/2000	15:00	PST	Tomado	F0	0	1	35.00K	0.00K
MOLALLA	CLACKAMAS CO.	OR	10/09/2000	18:15	PST	Tomado	F1	0	0	50.00K	0.00K
OREGON CITY	CLACKAMAS CO.	OR	10/09/2000	19:10	PST	Tomado	F1	0	0	35.00K	0.00K
BROTHERS	DESCHUTES CO.	OR	05/23/2001	14:07	PST	Tomado	F0	0	0	0.00K	0.00K
BURNS	HARNEY CO.	OR	08/09/2001	16:30	PST	Tomado	F0	0	0	0.00K	0.00K
BURNS	HARNEY CO.	OR	08/09/2001	16:50	PST	Tomado	F0	0	0	0.00K	0.00K
BROTHERS	DESCHUTES CO.	OR	09/25/2001	11:25	PST	Tomado	F0	0	0	0.00K	0.00K
(PDT)PENDLETON ARPT	UMATILLA CO.	OR	07/13/2002	15:14	PST	Tomado	F0	0	0	0.00K	0.00K
BROOKINGS	CURRY CO.	OR	11/09/2002	06:05	PST	Tomado	F0	0	0	500.00K	0.00K
INDEPENDENCE	POLK CO.	OR	06/21/2003	09:00	PST	Tomado	F1	0	0	0.00K	0.00K
FOX	GRANT CO.	OR	10/04/2003	14:42	PST	Tomado	F0	0	0	0.00K	0.00K
KLAMATH FALLS ARPT	KLAMATH CO.	OR	04/17/2004	16:00	PST	Tomado	F0	0	0	0.00K	0.00K
STANFIELD	UMATILLA CO.	OR	05/23/2004	15:40	PST	Tomado	F0	0	0	0.00K	0.00K
RAINIER	COLUMBIA CO.	OR	06/06/2004	14:15	PST	Tomado	F0	0	0	0.00K	0.00K

MADRAS	JEFFERSON CO.	OR	06/09/2004	10:40	PST	Tomado	F0	0	0	1.00K	0.00K
SHERWOOD	WASHINGTON CO.	OR	06/18/2004	19:45	PST	Tomado	F0	0	0	0.10K	0.00K
BAKER	BAKER CO.	OR	06/23/2004	19:10	PST	Tomado	F0	0	0	0.00K	0.00K
RITTER	GRANT CO.	OR	07/19/2004	14:07	PST	Tomado	F1	0	0	0.00K	0.00K
SUMMER LAKE	LAKE CO.	OR	08/21/2005	16:05	PST	Tomado	F0	0	0	0.00K	0.00K
BOARDMAN	MORROW CO.	OR	05/19/2006	15:05	PST	Tomado	F1	0	0	20.00K	0.00K
WAGONTIRE	HARNEY CO.	OR	06/13/2006	12:55	MST	Tomado	F0	0	0	0.00K	0.00K
ENTERPRISE	WALLOWA CO.	OR	08/21/2006	10:30	PST	Tomado	F0	0	0	0.00K	0.00K
SALEM	MARION CO.	OR	12/16/2006	15:00	PST-8	Tomado	F0	0	0	0.00K	0.00K
KENO	KLAMATH CO.	OR	04/17/2007	14:37	PST-8	Tomado	EF0	0	0	0.00K	0.00K
LEBANON	LINN CO.	OR	09/28/2007	17:00	PST-8	Tomado	EF0	0	0	20.00K	22.00K
CAYUSE	UMATILLA CO.	OR	05/06/2009	15:55	PST-8	Tomado	EF1	0	0	50.00K	0.00K
WALLOWA	WALLOWA CO.	OR	05/06/2009	17:15	PST-8	Tomado	EF0	0	0	100.00K	0.00K
PEORIA	LINN CO.	OR	06/04/2009	14:35	PST-8	Tomado	EF0	0	0	10.00K	0.00K
REDLAND	CLACKAMAS CO.	OR	10/26/2009	15:15	PST-8	Tomado	EF0	0	0	50.00K	0.00K
NEOTSU	LINCOLN CO.	OR	11/06/2009	21:30	PST-8	Tomado	EF0	0	0	35.00K	0.00K
PORT ORFORD	CURRY CO.	OR	10/24/2010	16:20	PST-8	Tomado	EF0	0	0	0.00K	0.00K
AUMSVILLE	MARION CO.	OR	12/14/2010	19:40	PST-8	Tomado	EF2	0	2	1.200M	0.00K
LEXINGTON	MORROW CO.	OR	04/14/2011	15:15	PST-8	Tomado	EF0	0	0	0.50K	0.00K
LOSTINE	WALLOWA CO.	OR	05/09/2013	14:30	PST-8	Tomado	EF0	0	0	0.00K	0.00K
MC MINNVILLE	YAMHILL CO.	OR	06/13/2013	16:32	PST-8	Tomado	EF1	0	0	0.00K	100.00K
WINCHESTER	DOUGLAS CO.	OR	06/18/2013	14:30	PST-8	Tomado	EF0	0	0	1.00K	0.00K
EUGENE	LANE CO.	OR	04/14/2015	16:05	PST-8	Tomado	EF0	0	0	25.00K	0.00K
WATERMAN	WHEELER CO.	OR	06/08/2016	19:22	PST-8	Tomado	EF0	0	0	0.00K	0.00K
ROBERTS BUTTE	WALLOWA CO.	OR	07/12/2016	15:58	PST-8	Tomado	EF0	0	0	0.00K	0.00K
MANZANITA	TILLAMOOK CO.	OR	10/14/2016	07:18	PST-8	Tomado	EF2	0	0	1.000M	0.00K
OCEANSIDE	TILLAMOOK CO.	OR	10/14/2016	08:00	PST-8	Tomado	EFU	0	0	0.00K	0.00K
BEND	DESCHUTES CO.	OR	04/13/2017	16:00	PST-8	Tomado	EF0	0	0	0.00K	0.00K
LACOMB	LINN CO.	OR	09/19/2017	12:07	PST-8	Tomado	EF1	0	0	240.00K	0.00K
AURORA AAPT	MARION CO.	OR	10/12/2017	14:39	PST-8	Tomado	EF0	0	0	40.00K	0.00K
ST JOHNS	MULTNOMAH CO.	OR	10/28/2018	13:57	PST-8	Tomado	EF0	0	0	7.00K	0.00K
FOREST GROVE	WASHINGTON CO.	OR	10/29/2018	13:17	PST-8	Tomado	EF0	0	0	100.00K	0.00K
JEFFERSON	MARION CO.	OR	10/29/2018	14:30	PST-8	Tomado	EF0	0	0	0.20K	0.00K
SPRAGUE RIVER	KLAMATH CO.	OR	05/28/2019	14:55	PST-8	Tomado	EF0	0	0	0.00K	0.00K
BLITZEN	HARNEY CO.	OR	06/01/2019	11:17	PST-8	Tomado	EF0	0	0	0.00K	0.00K
ST JOHNS JCT	MULTNOMAH CO.	OR	07/01/2019	16:24	PST-8	Tomado	EF0	0	0	21.00K	0.00K
RIVER JCT	MULTNOMAH CO.	OR	09/08/2019	17:44	PST-8	Tomado	EF0	0	0	8.00K	2.00K
DAMASCUS	CLACKAMAS CO.	OR	06/13/2020	17:28	PST-8	Tomado	EF0	0	0	0.00K	0.00K
ST HELENS	COLUMBIA CO.	OR	11/10/2020	12:20	PST-8	Tomado	EF0	0	0	40.00K	0.00K
BINGHAM SPGS	UMATILLA CO.	OR	05/06/2022	12:44	PST-8	Tomado	EF1	0	0	0.00K	0.00K
BARNHART	UMATILLA CO.	OR	06/11/2022	11:00	PST-8	Tomado	EFU	0	0	0.00K	0.00K
CHERRYVILLE	CLACKAMAS CO.	OR	10/22/2022	16:40	PST-8	Tomado	EF0	0	0	50.00K	0.00K
WEST WOODBURN	MARION CO.	OR	10/24/2022	15:30	PST-8	Tomado	EF0	0	0	25.00K	0.00K
Totals:								0	5	32.466M	125.00K