

Staff's Third Round of Comments in AR 506 & AR 510  
Dated November 17, 2006

The Staff of the Public Utility Commission of Oregon (OPUC) respectfully submits the following comments:

Sanction Rules (AR 510)

The Oregon Joint Use Association (OJUA) did not file its final proposed AR 510 rules language before Staff prepared these Comments. Consequently, Staff has not had sufficient time to review nor comment on OJUA's final proposal for AR 510. Staff supports those changes to the Sanction rules that are clear and simple that will improve the cooperation and coordination between owners and occupants and that will promote "safe and efficient poles, installation practices and rights of way" (as mandated by House Bill 2271 of 1999). Staff recommends that rule 028-0120 be re-titled "Duties of Occupants" and made applicable to all occupants that attach to poles, conduits and joint use facilities. The sections and provisions within this rule should be changed to apply to both the occupancy of poles and conduits where practical.

Duties of Owners' Rule

Staff recommends that the rule 028-0115 be re-titled "*Duties of Owners*" and be made applicable to all owners of poles and conduits. The sections and provisions within this rule should be changed to apply to ownership of both poles and conduits where practical.

Cost of Money for Consumer-owned Utilities

For each calendar year, in order to accurately reflect the cost of money for Consumer-owned utilities (e.g., cooperatives, peoples utility districts, and municipalities), Staff recommends that the most recent Commission general rate order decision adopting a rate of return for an electric utility be used as the basis for setting the cost of money for consumer-owned utilities. In order to reflect a lower risk or lower required return on equity-like contributions, Staff recommends two possible solutions.

Solution #1: The Consumer-owned utility's cost of money would be equal to the weighted average cost of the consumer-owned utilities debt and a proxy equity cost. Assuming the prior year's Commission most recent decision on cost of capital for an electric utility is 10% cost of equity with a 50% capital structure, the proxy equity cost would equal 10% - 2% or 8%. This cost would further be reduced (increased) should the consumer-owned utility have a more (less) equity-like-rich capital structure. If the Consumer owned utility had 54% (46%) equity, then the equity proxy would further be reduced (increased) by 4 basis points per each 1 % increase in equity-like funding. In this instance that would result in a 16 basis point (0.16%) reduction (increase) in the cost of equity.

For example, assume a Consumer-owned utility had 90% equity-like capital and 10% debt. If the most recent cost of capital decision were 10% cost with 50% equity, then the Consumer-owned utility's cost of money would be as follows:

	Cost	weight	contribution
Debt	5%	10%	0.5%
Equity	6.4%	90%	5.76%
Total cost of money = 5.76%+0.5% = 6.26%			

$$(6.4\% = 10\% - 2\% + (50-90)*0.04 )$$

If the utility were more leveraged (i.e., its capital structure contained more debt) then the proxy cost of equity would be increased. For example, if a consumer-owned utility had 45% equity-like capital, then the cost of equity proxy that would be averaged with its embedded cost of debt would equal 10% - 2% + 0.2% = 8.2%. Please see the attached spreadsheets for additional examples.

The benefits of this solution are that it takes into account recent market trends and reflects the opportunity cost of money for the consumer-owned utility. Further, it is flexible and applies to all consumer-owned utilities regardless of their capital structure (e.g., a situation where there is no debt). A drawback is that it assumes an adjustment to cost of equity that is not directly observable.



Solution #2:

For a consumer-owned utility, the cost of money is equal to the utility's embedded cost of long-term debt plus 100 basis points. Should a consumer-owned utility not have any long-term debt, then the rate will be set at the 10-year treasury rate as of the last traded day for the relevant calendar year plus 200 basis points. Please *see Attachment D* for examples.

The merit of this solution is that it is simple to apply. Further, in today's market, it appears to provide similar results to Solution #1 when the consumer-owned utility has long-term debt. The drawbacks of this solution are that it is not necessarily linked to market conditions (i.e., a commission decision on equity returns) and that for consumer-owned utilities with no long-term debt, a proxy debt instrument (10-year US Treasury Rate) is required.

Staff's proposed language for OAR 860-028-0020(3)(e)(C) is:

(C) For a consumer-owned utility, the cost of money is equal to the weighted average of the utility's embedded cost of long-term debt and the cost of equity equal to the most recent cost of equity authorized by the Commission for an electric company as defined in OAR 860-038-0005 minus 200 basis points. The assumed equity cost is also further adjusted to reflect the actual capital structure of the consumer-owned utility. To adjust for the capital structure of the consumer-owned utility, every 1% increase (decrease) in the percentage of equity in the capital structure from that associated with the most recent cost of equity decision will result in an downward (upward) adjustment of four basis points to the cost of equity.

Alternatively:

(C) For a consumer-owned utility, the cost of money is equal to the utility's embedded cost of long-term debt plus 100 basis points. Should a consumer-owned utility not have any long-term debt, then the rate will be set at the 10-year treasury rate as of the last traded day for the relevant calendar year plus 200 basis points.

Costs of Attachments in Pole Support and Clearance Space

Charter has requested that the following rule language be added within rule 028-0110:

In no event shall licensee equipment or other Attachment located in the 20 feet of safety clearance space be considered as occupying Authorized Attachment Space for rental rate purposes.

Pole attachments installed within the first 20-feet on a pole should not given rent-free status. Attachments such as cable television power supplies, telephone terminal boxes, and other equipment located in the support space on poles result in increased burdens and costs to pole owners and occupants. This especially becomes costly and problematic when poles have to be replaced or relocated.

Charter also recommends that “usable” be inserted before “space occupied” in the definition of “Authorized Attachment Space” in rule 028-0020. Staff opposes this proposal. With owner authorization, an occupant may put equipment in the support space on a pole, but the occupant should pay appropriate rent for such attachments in proportion to the vertical space used on the pole. This policy is set out in Commission Order 84-278 in the “Usable Space Occupied” section, which states:

Attachments create loads on poles by their weight and size. They also make climbing the pole more difficult and can increase the difficulty of gaining access to other attachments. In determining the portion of the pole an attachment occupies, the total vertical space it occupies including brackets, amplifiers, junction boxes, looped or dangle wires, and other space rendered unavailable to others, is included.

This order is clear that the licensee's attachment rate should be determined by the “total vertical space” occupied by the attachment on the pole, not by the “total vertical usable space” used. The Authorized Attachment Space definition should not be limited to the usable space on poles.

With new deployments by the wireless industry in attaching antennas and equipment on utility poles, Staff is concerned that if the pole support spaces are rent-free, poles will become crowded and cluttered with antennas, terminal boxes, power supply enclosures and the sort. This would result in unjust and unfair treatment to pole owners or to other

occupants. *See* Attachment A for pictures of applicable examples of enclosures, boxes, and other items installed in the support space on a pole.

#### Fees for New Attachments

An owner should be allowed on a pole-by-pole (or conduit-by-conduit) basis to recover out-of-pocket costs and require reasonable advance payments from an applicant for each new attachment to an owner's pole or conduit facilities. This should include all costs for administration, engineering, inspection, and construction necessary for the new attachment. Application processing, preconstruction activity, make ready, and post construction inspection for a new attachment are all considered by Staff to be one-time activities that are non-recurring. Per ORS 757.282, the owner is entitled to not less than "... all the additional costs of providing and maintaining the pole attachment space ..." as long as the charges are excluded from the annual rental rate. Staff supports an owner's option to recover all costs for non-recurring activities until the new attachment installation is placed in service in compliance with NESC rule 214(A)(1)<sup>1</sup> and the owner accepts the attachments.

Each industry (electric, telecommunications, cable television, and wireless) has unique needs in making and maintaining attachments. New attachment up-front costs can vary widely depending on the needs of the applicant and the owner and the specific the facilities involved. For example, the cost for a new attachment to a distribution pole will be different from that for a transmission pole. Also, the cost to attach a wireless antenna to a pole top will be different from a residential service drop attached within the "communication usable space" on a pole. A licensee should have to pay for the unique costs that its new attachment causes to the owner.

Many responsible occupants competently carry-out their administrative, engineering, construction and inspection functions in permitting and installing new attachments on poles. However, there are some occupants that perform shoddy administration, engineering, construction, and inspections in making new attachments causing the owner

---

<sup>1</sup> National Electrical Safety Code, as adopted in ORS 757.035 and OAR 860-024-0010.

added administrative and technical service costs. For example, if a new attachment fails the owner's post construction inspection because of sloppy work that is non-compliant with the owner's permit or Commission safety rules, the owner will have to come back for a second post inspection after the occupant has been given the opportunity to make the corrections. The owner should be allowed to directly charge this second inspection (including administration) as well as the first inspection to the specific occupant involved. There is a natural incentive (or consequence) here that will encourage an occupant to plan and build its attachments properly from the outset. Those occupants that perform shoddy work in complying with owner permits and Commission safety rules cause owners excessive administrative, engineering, inspection and compliance work. Those remiss occupants should bear the burden for the additional efforts and costs imposed on the owner. Conscientious owners and responsible occupants should not have to pay for (or subsidize) the careless work and unresponsiveness of others.

Owners should be given the option to charge reasonable application fees for new attachments by applicants. In making an attachment application, an occupant is effectively reserving space on a pole or conduit until the attachment is made. It is appropriate that the applicant should pay an up-front fee to the owner to begin processing the attachment permit as well as to reserve the space. The applicant has the right to cancel a new attachment application and project at any time. If the applicant does not pay application fees and it cancels its project, then the applicant is causing the owner unnecessary work and costs. This may become a more important concern as wireless providers and other telecommunications service providers, including electric utilities, aggressively compete for new attachment space on poles, conduits and towers.

#### No Double Charging to Pole Occupants

One provision needs to be added to the "Duties of Owners" rule, which reads:

An owner may not assess a fee or charge in addition to an annual attachment rental rate, including any non-recurring fee or charge described in OAR 860-028-0100, OAR 860-028-0110, and OAR 860-028-0310, for any cost included in the calculation of its annual attachment rental rate.

Some utility owners cannot break out their administrative costs associated with new attachments from their annual rent calculations. These owners should recover their administrative costs through their rental rate formula for recovering fully allocated costs.

#### Appropriate Rental Rate Formula for Oregon

This issue was first brought up by Idaho Power in its comments. Staff made a preliminary response in its Second Round of Comments. Staff would like to elaborate further on this matter. The FCC has two formulas for pole-attachment rental rates: one for cable television companies and one for telecommunications service providers. The first one involves the Cable formula – implemented in 1978 – is based on the portion of the pole space used by the attachment. The other is the Telecommunications formula that was adopted by the federal Telecommunications Act of 1996 for new telecommunications service providers. The Telecommunications formula uses a different methodology for determining the proportion of pole space that is attributable to the attachment. It allocates the cost of the “unusable” portion of the pole based on the total number of pole occupants rather than on the portion of space occupied by the attachment.

Oregon currently has only one formula that is applicable to all licensees, including cable television operators, telephone utilities, competitive telecommunication providers, electric utilities and other licensees that are authorized to install attachments on the public rights of way. Oregon's formula is very similar to the FCC's Cable formula.

Staff believes that the OPUC should review the attachment rate principles (allocation of costs and benefits) related to occupant attachments to poles. OPUC should consider adopting the FCC's two-formula approach. This would involve an investigation to determine whether there should be one rental rate or two for attachments to poles. If one formula is to be retained, should the PUC adopt the FCC Telecommunications formula? Staff believes that Telecommunications formula may be more applicable and equitable today for owners and occupants. The FCC Telecommunications formula seems more applicable for wireless attachments because of its need for “electric supply space” and pole tops of distribution and transmission. Staff recommends that this review be

conducted in a separate docket that would look closer at wireless attachments and appropriate Division 024 and 028 rules for them. However, for this docket Staff recommends that the Commission adopt the rental rate formula proposed in rule 028-0110, specifically covered in section (3).

Wireless Attachment Issues

This is in follow-up to Staff's Second Round of Comments in this docket. Staff submits in *Attachment B* a list of wireless antenna issues that need to be addressed in OPUC Division 024 safety rules and separately in Division 028 attachment rate, terms, and condition rules. Staff also submits significant industry documents in *Attachment C* that support the potential dangers and attachment rates and conditions raised by Staff. The parties, both owners and occupants, have not satisfactorily addressed the issues raised by Staff to its satisfaction. Staff's and other issues first need to be vetted out in informal workshops with representatives from the OJUA, Staff and the industry participating. Afterwards, the results of those workshops should then be addressed in a separate OPUC rulemaking docket.

/s/

Jerry Murray  
Senior Utility Analyst

Attachments A, B, C and D follow

## Attachment A

### Pictures of Pole Attachments in the Support Space on a Pole

This page illustrates a CATV power supply box from various angles. Dimensions are typically 16 in high by 12 in wide by 7 in deep. Weight is up to 50 lbs. These can be seen on many poles in Oregon.



These CATV power supplies are not incidental items. They cause burdens and costs to owners and occupants in maintenance issues. Should these items be rent-free?

(Except for one picture identified , these pictures were not taken in Oregon to Staff's knowledge)



This picture taken in Oregon by PUC Safety Staff



## Attachment A

### Pictures of Pole Attachments in the Support Space on a Pole

This page illustrates wireless enclosures mounted on utility poles. Should these be rent-free?

(These pictures were not taken in Oregon to Staff's knowledge)





Attachment B  
Issues Related to Wireless Attachments to Poles, Structures, and Towers

Page 1 of 3

List of specific wireless concerns that should be addressed in a separate informal industry workshops and later in a separate rulemaking docket from AR 506 and AR 510

Division 024 Safety Issues related to wireless and antenna attachments:

- Worker training and qualifications (for line workers)
- Elec. utility, pole owner (or NESC employer) responsibilities for wireless attachments?
- Structural integrity (especially associated with ice and wind storm loadings)<sup>1</sup>
  - Pole structural engineering and integrity? For electric utility owned poles? For telephone company owned poles?
  - Is the NESC appropriate? Or are ASCE structural standards necessary for Oregon?
  - NESC structural requirements do not necessarily provide adequate structural minimums in high wind and ice areas (e.g. Oregon Coast and Columbia River)
  - Antenna material/strength specifications and mounting details?
- Access to electric supply space on poles<sup>2</sup>
- Pole climbing space and equipment access
- Electrical shock hazard and grounding for line workers & members of the public
  - Lightning protection?<sup>3</sup>
  - Ground potential rise (GPR)?<sup>4</sup>
- Radio Frequency (RF) emissions and exposure for line workers<sup>5 6</sup>
  - Powering down antennas during emergency conditions?
  - Powering down antennas during routine maintenance and scheduled conditions?
  - Warning and caution signage?
- Occupant marking (labeling) requirements
- Inspection quality and frequency (e.g., ongoing patrols, detailed inspections, new Q/C)
- Prioritization of repairs – correction timelines
- Line to antenna clearances
- Vegetation clearances and programs for clearances to antennas and pole top structures
- FAA aviation markers and safety requirements. Aircraft collisions to lines - an issue!
- What is the wireless industry intentions for deployment of new antenna attachments to utility poles and public utility rights of way in Oregon? Rapid mass deployments?
- Other State Wireless Safety Rulemakings (California PUC General Order 95)<sup>7 8</sup>
- New proposed federal regulations<sup>9</sup>
- OJUA participation? Is the wireless industry going to be a joint-use community partner?
- OPUC safety staffing and cost recovery

Attachment B  
Issues Related to Wireless Attachments to Poles, Structures, and Towers  
Page 2 of 3

Division 028 Attachment Issues related to wireless and antenna attachments (rates, terms and conditions):

- Appropriate annual rental rates for fully allocated costs
  - Are the incremental costs for wireless attachments to poles higher than the fully allocated rental rates?
  - Is the OPUC (similar to FCC cable rate) fully allocated cost formula appropriate for pole owner cost recovery?
  - Should tall (e.g. 80 ft.) antenna on distribution poles be combined into FERC 364 accounts to determine distribution pole costs?
  - Wireless in the pole support/clearances (first 20 feet on poles) be rent-free?
- Processes for new wireless applications and new installations
  - Is the 45-day and other timelines in 028-0100 adequate or fair to the owners?
  - Owner denial rights for attachment lack of capacity? 80 foot pole required in distribution line?
- Communication Protocols
  - Between owners and wireless occupants?
  - Between wireline occupants and wireless occupants?
  - National Joint Utility Notification System communications adequate?
- Dispute Resolution processes
  - Cost recovery for OPUC, Staff, ODOJ, etc?
- Pole replacement and transfer processes and costs
  - Put in carrying charges for fully allocated rates?
- Abandonment processes and costs
  - Put in carrying charges for fully allocated rates?
- Application, administrative, and inspection fees
  - Put in carrying charges for fully allocated rates?
- Make-ready
  - Performed and controlled by owner for electric supply space and pole top attachments?
- Replacements, rearrangements, and ongoing maintenance
  - Performed and controlled by owner for electric supply space and pole top attachments?
- Impacts to regulated utility customers and members of the public
  - Community aesthetic and other complaints?
  - Property rights and easements complaints?
  - Customer complaint handling?
- Addendums for Pole Attachment Contracts<sup>10</sup>
- Tower design, safety coordination and control (Owner –Occupant)<sup>11</sup>

Attachment B  
Issues Related to Wireless Attachments to Poles, Structures, and Towers  
Page 3 of 3

- Protection of Critical Infrastructure<sup>12 13</sup>
- OPUC Staffing and cost recovery for pole attachment issues

**End Notes – (see Attachment C for some of the below documents)**

<sup>1</sup> National Electrical Safety Code Interpretation for Rules 252A and 251A3, July 28, 2004, *See* <http://standards.ieee.org/nesc/NESCIR538.pdf>

<sup>2</sup> Licensee Amendment and Addendum to Distribution Pole Attachment Agreement (sample), Niagara Mohawk Power Corporation, d.b.a National Grid , *See* Access to Electric Space. *See* website document at:  
[http://www.nationalgridus.com/niagaramohawk/attachments/wireless/non\\_html/distr\\_pole\\_wireless\\_agreement.pdf](http://www.nationalgridus.com/niagaramohawk/attachments/wireless/non_html/distr_pole_wireless_agreement.pdf)

<sup>3</sup> Article: DAMAGE FROM LIGHTNING TO PCS TOWER EQUIPMENT IS \$150 M A YEAR AND LIGHTNING IS UPON US AGAIN, (*see* <http://press.arrivenet.com/technology/article.php/777537.html> )

<sup>4</sup> See Attachment C, item 4 from November 17, 2000 safety presentation to the Oregon Utility Safety Committee (sponsored by the Oregon PUC) – High Voltage Safety Concerns Associated with Power Substations and Transmission Towers, Tim Conser from QWEST.

<sup>5</sup> 2007 NESC Changes Newsletter, Dave Marne Associates, November 2006

<sup>6</sup> Same as note 2 (Niagara Mohawk Power Corporation Addendum) , page 7, Interference

<sup>7</sup> Proposed Joint Use Safety Regulations for California PUC in addressing wireless issues, *See* website [http://www.go95-rc.com/docs/Draft%20GO%2095%20Rules%20for%20Pole%20Top%20Antennas%20\(041006\).doc](http://www.go95-rc.com/docs/Draft%20GO%2095%20Rules%20for%20Pole%20Top%20Antennas%20(041006).doc)

<sup>8</sup> Draft Decision in California PUC Rulemaking 05-02-023 for Safety General Order 95 for Wireless Attachments, ALJ Walker,, dated 11-9-06

<sup>9</sup> Pole Attachments Power Point Presentation, Edison Electric Institute, *See* [http://www.eei.org/industry\\_issues/energy\\_infrastructure/distribution/Pole\\_Attachments\\_101.ppt#256,1,Pole Attachments 101](http://www.eei.org/industry_issues/energy_infrastructure/distribution/Pole_Attachments_101.ppt#256,1,Pole Attachments 101)

<sup>10</sup> Same as note 2 (Niagara Mohawk Power Corporation Addendum), *See* entire document

<sup>11</sup> Guidelines for Attachment of Communication Antennas to AEP (American Electric Power) Transmission Structures, May 7, 2002, *See* <http://www.aeptowers.com/files/PCSGuidelines.doc>

<sup>12</sup> EEI Letter on Pole Attachment to US Senate, Thomas R. Kuhn, *See* [http://www.eei.org/about\\_EEI/advocacy\\_activities/Congress/060616KuhnSenatePole.pdf](http://www.eei.org/about_EEI/advocacy_activities/Congress/060616KuhnSenatePole.pdf)

<sup>13</sup> Statement for the Record by Edison Electric Institute on Hearing on State and Local Issues and Municipal Networks, November 14, 2006, *See* [http://www.eei.org/about\\_EEI/advocacy\\_activities/Congress/060214EeiSenateCommerceTelecommunications.pdf](http://www.eei.org/about_EEI/advocacy_activities/Congress/060214EeiSenateCommerceTelecommunications.pdf)

# National Electrical Safety Code Committee, Accredited Standards Committee C2

## National Electrical Safety Code®

### Interpretation

#### Section 25. Loadings for Grades B and C

**Rule 252A Loads on Line Supports—Assumed Vertical Loads (2002 Edition, page 171)  
(28 July 2004) IR538**  
**Rule 251A3 Conductor Loading—General (2002 Edition, page 170)  
(28 July 2004) IR538**

**(Rule 252A)** For installations located in NESC Medium and Heavy Load Districts, should radial ice be considered on vertically oriented communications cables running from the ground to PCS antennas installed near the upper portions of lattice, steel, or wood structures and poles?

**(Rule 251A3)** If yes, how should the ice coating be calculated in a multiple conductor bundle and can shielding from the wind be considered?

**Discussion:** In recent years, there have been numerous installations of PCS (wireless communications) antennas and cables added to overhead electric power line structures. These structures have included types such as lattice steel towers and poles made of steel, wood, and concrete.

In most instances, the antennas are multiple flat panels located near the top of the tower with either 2 or 4 coax cables running from the ground to each panel. A typical installation would have 3 or 4 panels pointed in 3 sectors for a total of 12 panels at one elevation. Up to 36 cables would then be routed from the ground to the antenna elevation. These cables are typically 1 in to 2 in in diameter each with individual weights per foot of 0.3 lb to 1.0 lb.

On poles, the cables are generally placed inside of conduit or covered. On lattice steel structures, they can be grouped in bundles and supported by brackets attached to legs or placed in cable ladders installed on the face of the tower.

The installations described above were probably not given a large amount of consideration over the years during the development of the NESC but have become common enough and involve loads substantial enough to require being addressed.

#### **Rule 252A**

While Rule 252A states “Loads due to radial ice shall be computed on wires, cables, and messengers, but need not be computed on supports” it is traditional to not consider ice on guy wires, ground wires, etc. presumably because these are vertically oriented and, in the case of guy wires, are considered a part of the “support”. Neither is ice considered on equipment such as antennas, transformers, cabinets, conduits, insulators, etc. Ice has traditionally only been considered on wires, cables, and conductors supported by the structure and running laterally.

Should vertically oriented communications cables be treated as “equipment” and not be subject to ice loading? If yes, should they be subject to ice loading when covered or located in conduit? Should the cover or conduit be considered as ice coated?

**Rule 251A3**

If the response to Rule 252A is that ice loading need not be considered, this second part of the request becomes partly mute. Otherwise, there are questions regarding how the ice should be calculated and whether wind shielding is appropriate.

1. If the cables are located in a cable ladder, it would seem appropriate to treat the cable ladder as a solid object and apply wind to the area defined by its width using a shape factor consistent with a flat surface. This could be less than the sum of areas represented by the total number of cables located in the ladder, especially if installed in layers. The ice (if required) could then be added to the assumed solid object and for weight purposes be calculated as coating a rectangular shape. This would seem to be consistent with Rule 252Bc.
2. If the cables are supported in a cylindrically shaped bundle on a “hoop” type support where each cable would be tightly spaced, it would seem appropriate to treat this as a hollow cylinder and apply the radial ice on the outside, especially if the gap between the cables was less than the ice thickness assumed. If agreed, should one also consider ice coating along the inside surface of the hollow cylinder? Is it appropriate then to apply the wind on the solid defined by the outer diameter using a shape factor consistent with a cylinder? If not, it would at least seem appropriate to use no more than 2/3rds the total area of the cables consistent with Rule 252B1—Exception?

**Interpretation**

The Interpretations Subcommittee has considered the subject Interpretation Request for Rule 252A and Rule 251A3 and has developed a consensus report as follows:

“Rule 252A requires computation of radial ice loading on wires, cables, and messengers but does not specifically require such a computation on supports (“...need not be...”). The intent of this rule is to require ice loading computation on longitudinal and transverse spans running between supports but not on vertical runs. In other words, the intent of Rule 252A is to treat vertical runs on a single structure in the same manner as supports with respect to ice loading.

However, the types of installations that have been described above have not been specifically considered in the development of Rules 251 and 252. As stated above, such installations are relatively new and may involve substantial loadings due to ice and wind. Consequently, Rule 012C may apply. This rule requires that construction and maintenance be done in accordance with accepted good practice for particulars not covered in the NESC rules. Both the weight of the ice and the wind loading due to the ice may adversely affect the stress on fasteners, support components, and even the supporting structure itself. This is of particular concern when the vertical run assembly is such that ice may bridge the components and become a solid mass.

As additional information and not as part of this interpretation, NESC Subcommittee 5 has been requested to review the ice loading rules applicable to the types of installations that have been described above.”

~~Item 2~~

**License Amendment and Addendum to  
Distribution Pole Attachment Agreement**

THIS AMENDMENT and ADDENDUM, made this day of \_\_\_\_\_, 20\_\_, between Niagara Mohawk Power Corporation<sup>1</sup>, a corporation organized and existing under the Laws of the State of New York, having its principal office at 300 Erie Boulevard West, Syracuse, New York, "Licensor", and \_\_\_\_\_, a \_\_\_\_\_ corporation, having its principal office at \_\_\_\_\_, "Licensee", collectively referred to as the "Parties". The Parties hereto agree to amend the existing pole attachment agreement between the Parties, dated \_\_\_\_\_. Except as modified herein, all other terms and conditions of the existing pole attachment agreement shall remain unchanged. In the event of conflict, the language in this amendment and addendum shall prevail.

**WITNESSETH**

WHEREAS, Licensee desires to install, own and operate wireless facilities on wood electric system Poles of Licensor; and

WHEREAS, Licensor is willing to permit, under the conditions described herein, the placement of said wireless facilities on Licensor Poles, and

WHEREAS, Licensor and Licensee have previously entered into an agreement for use of Licensor's wood electric distribution Poles for traditional wireline attachments;

NOW, THEREFORE, in consideration of the mutual covenants, terms, and conditions herein, and other good and valuable consideration, the parties do hereby mutually covenant and agree as follows:

**1. DEFINITIONS:**

As used in this Amendment and Addendum:

**Addendum** – shall mean this agreement authorizing via license, Licensee's attachment of Wireless Facilities to Licensor's electric system Poles.

**Agreement** – shall mean the existing Pole Attachment Agreement between Licensor and Licensee, under which Licensee is permitted to attach communication wires and related devices to or upon the Communication Space of electric distribution Poles.

<sup>1</sup> Niagara Mohawk Power Corporation, d.b.a. National Grid. The National Grid companies include: Granite State Electric, Massachusetts Electric Co., Nantucket Electric Co., National Grid USA Service Co. Inc., New England Power Co., Niagara Mohawk Power Corp., and The Narragansett Electric Co.

**Communication Space** – shall mean that portion of the usable Pole space in which communication wires and devices have traditionally been located and that can be accessed by a Qualified Communication Worker.

**Electric Space or Supply Space** - shall mean that space on Licensor's wood electric distribution Poles where Licensor has installed or may install energized electric conductors and related electric equipment. This space is the "supply space", as defined in the National Electric Safety Code (NESC). All work performed within this space shall be performed by Qualified Electrical Workers.

**Good Utility Practice** – shall mean any of the practices, methods and acts engaged in or approved by a significant portion of the electric utility industry during the relevant time period, or any practices, methods and acts which, in the exercise of good judgment in light of the facts known at the time the decision was made, could have expected to accomplish the desired result at the lowest reasonable cost consistent with good business practices, reliability, safety and expedition. Good Utility Practice is not intended to be limited to the optimum practice, method or act, to the exclusion of all others, but rather to be acceptable practices, methods, or acts generally accepted in the region and consistently adhered to by the Licensor. Good Utility Practice shall include conformance to the policies, criteria, practices, guidelines and requirements of the National Electric Reliability Council, the Northeast Power Coordination Council and the New England or New York Independent System Operators, or their successor organizations.

**Pole** - shall mean a wood pole supporting electric system circuits of 34,500 volts or less and available for attachment of Wireless Facilities.

**Qualified Communication Worker** – a worker meeting all current training and experience requirements of all applicable federal, state and local work rules and of the Licensee, including OSHA 1910.268.

**Qualified Electrical Worker** – a worker meeting all training and experience requirements of all applicable federal, state, and local work rules and Licensor work rules, including OSHA 1910.269.

**Wireless Facilities** – shall mean any antenna, hardware, equipment, apparatus, device or other hardware, and cables or wires connecting such antenna to such equipment, apparatus, device or other hardware placed on the same Pole (Exhibit #3). This shall not include any microwave dishes and/or wires or cables used to connect to other wireless or wired communication facilities or equipment not on the same pole. All facilities that comprise a portion of an attachment authorized under this Addendum, whether owned by Licensee or by others, shall, for the purposes of this Addendum, be considered part of "Licensee's Wireless Facilities" and Licensee shall accept full responsibility for such facilities under the provisions of this Addendum.

## **2. SCOPE OF THE AMMENDMENT and ADDENDUM:**

- 2.1 Licensor agrees to license installation of Wireless Facilities on Licensor's Poles consistent with Licensor's core business requirements and generally accepted safety, operational, reliability and engineering requirements. Notwithstanding the above, nothing contained herein shall be construed to compel the Licensor to construct, reconstruct, retain, extend, repair, place, replace, maintain or make space available for attachment of Wireless Facilities on Licensor's Poles. Licensor reserves the right to revoke any licenses provided hereunder as necessary to ensure the safe and reliable operation and maintenance of Licensor's electric system.
- 2.2 The rights granted to Licensee by this Addendum shall constitute a revocable license to the extent such use is permitted pursuant to the terms of the applicable contracts, deeds, agreements, easements, leases, licenses, permits or franchises conveying to Licensor its individual legal rights in any public or private right-of-way.
- 2.3 Subject to the provisions of the Agreement and this Addendum, where Licensee has actually installed its Wireless Facilities at the top of a specific Pole, and such Pole is replaced, Licensee shall continue to have a right to use the top of the replacement Pole.
- 2.4 It is understood that Licensor's rights may not be sufficient to permit installation of Wireless Facilities and Licensee's use of the Pole. Licensee shall obtain, at its own cost and expense, all necessary franchise, licenses, permits or rights which relate to Licensee's installation and use of the Wireless Facilities and/or the Pole and the performance of its obligations hereunder. Licensee shall provide a copy of such documents to Licensor prior to attachment at Licensee's sole cost and expense.
- 2.5 Licensor will, upon written request by Licensee, subject to confidentiality provisions, provide available information and copies of documents in its files pertinent to the nature of the rights Licensor possesses. All costs, fees and expenses (including labor) of providing such information and reproducing documents shall be paid by Licensee.
- 2.6 Subject to Licensor review and acceptance, Licensee shall design, specify, and supply all material associated with the installation, operation and maintenance of Wireless Facilities.
- 2.7 The license granted Licensee shall provide Licensee a non-exclusive right-of-occupancy of Licensor's Pole, authorizing the installation, operation, use and maintenance of Wireless Facilities for the transmission and/or receiving of wireless telecommunication signals. The license does not provide Licensee



with any ownership interests in Licensor Pole, real property or the right-of-way and is for Licensee's sole use and purpose.

- 2.8 Wireless Facilities shall be installed and maintained by the Licensee at Licensees' sole cost and expense.
- 2.9 All make-ready work on Licensor facilities shall be performed by the Licensor or Licensor's contractor.
- 2.10 Licensor's Poles may be jointly owned. Prior to the Licensor authorizing use of jointly owned Poles, Licensee agrees to obtain and provide to Licensor the joint owner's prior written consent for proposed installation of Wireless Facilities. In the event Licensee does not obtain the joint owner(s) consent, no Wireless Facilities shall be installed.

### **3. INSTALLATION OF LICENSEE FACILITIES:**

- 3.1 Licensee will provide Licensor with a listing of all Poles Licensee seeks to make attachment to, including copies of the installation plans and specifications for such Wireless Facilities for Licensor's review and acceptance.
- 3.2 Following submittal, Licensor shall either (a) accept such plans and specifications in whole or in part, or (b) raise bona fide objections or reject the same, in which case Licensor shall describe in reasonable detail the basis for such objections or rejection and any modifications to such plans and specifications that can be made in order to obtain its acceptance. Notwithstanding anything herein to the contrary, Licensor agrees to exercise Good Utility Practice, with deference to Licensor's public service responsibilities, to assure that Licensee submittal is reviewed and accepted by Licensor in support of Licensee's construction schedule.
- 3.3 All proposed Wireless attachments will require a make-ready survey, to be performed by the Licensor at Licensee cost. Should joint owner or existing third party user participation be required for a field survey, Licensee shall coordinate and be responsible for obtaining joint owner and third party attendee participation in any required field survey. Licensee shall pay all joint owner and third party costs related to required field surveys.
- 3.4 Upon the completion of field survey and assessment of the survey results, Licensor shall provide Licensee a listing of required make-ready work (if any) including the cost to perform such make-ready work and the projected work schedule to complete.
- 3.5 License applications received by Licensor from two or more Licensees for Wireless Facilities accommodations on the same pole, prior to commencement of any field survey or make-ready work required to accommodate any

Licensee, will be processed by Licensor in accordance with the procedures detailed in Exhibit #5.

- 3.6 Licensor agrees to submit an estimated schedule for the completion of make-ready work within fifteen (15) days of receipt by Licensor of Licensee's advance payment for the make-ready work. Actual completion of make-ready work by Licensor will depend on completion of all required make-ready work by Licensee, other joint users or joint owners that must be completed prior to Licensor's performance of its make-ready work. In performing all make-ready work to accommodate Licensee's Wireless Facilities, Licensor will endeavor to include such work in its normal workload schedule.
- 3.7 Upon completion of all required make-ready work and Licensee securing all required permits and approvals, and prior notice by Licensee in accordance with Article 10 herein, the Licensee may proceed to install the approved Wireless Facilities with a qualified workforce. Installation of Wireless Facilities shall commence within sixty (60) days of release and shall be worked continuously until completion unless otherwise agreed to by Licensor.
- 3.8 Wireless Facilities installed by Licensee or Licensee's contractor, are subject to one (1) Licensor inspection during construction and one (1) Licensor inspection upon completion of construction: the cost of Licensor inspections are to be paid by the Licensee. Licensor shall estimate the cost of any Licensor inspection and Licensee shall pre-pay the estimated inspection costs and shall remain liable for any actual Licensor inspection costs in excess of the pre-paid estimated inspection fees. Post construction inspection of Wireless Facilities by Licensor shall be performed within thirty (30) days of Wireless Facilities installation.
- 3.9 In the event Pole replacement is required to accommodate the installation of Licensee Wireless Facilities, Licensee shall pay all costs related to Pole replacement including but not limited to Pole replacement, transfer of all existing facilities, and removal and disposal of the old Pole. Payment of Pole replacement costs does not provide Licensee with any ownership interest in the replaced Pole.
- 3.10 Licensee shall not be entitled to reimbursement from Licensor of any amounts paid to Licensor for Pole replacements or for rearrangement of attachments on Licensor's Poles by reason of the use by Licensor or other user(s) of any additional space resulting from such replacement or rearrangement.
- 3.11 In the event Licensor agrees to install and/or maintain Licensee Facilities, such installation and maintenance shall be performed under the terms and conditions of Licensor's standard agreement for provision of such services

(Services Agreement), the terms and conditions of which may be revised from time to time (Exhibit #2).

- 3.12 Licensee agrees to provide site specific radio frequency (RF) emission data and required worker clearances from operational Wireless Facilities.
- 3.13 Should Licensor, or other authorized Pole attachees require access to the Pole and such access is restrained as a result of Licensee's operational Wireless Facilities, Licensee shall work cooperatively to develop and support access requirements. Work shall be performed in accordance with Licensor safety standards, which may require temporarily ceasing wireless operations to comply with such standards.
- 3.14 Licensee shall post a notice at each wireless site providing a twenty-four (24) hour contact number and as applicable, radio frequency emission hazards.

#### **4. MAINTENANCE OF LICENSEE FACILITIES:**

- 4.1 Maintenance of all Wireless Facilities shall be performed by Licensee at Licensee's sole cost and expense. Licensee shall provide Licensor a minimum of ten (10) business days advance notice of the Licensee's need to perform routine or scheduled maintenance on Wireless Facilities located in the Electric Space.
- 4.2 Licensor agrees to not unreasonably delay, restrict or deny Licensee access to Wireless Facilities located in the Electric Space for emergency maintenance. Notwithstanding the above, Licensee shall make at least 1 hour notification to and receive authorization from Licensor prior to accessing any Wireless Facilities located in the Electric Space.
- 4.3 Unless otherwise agreed to, Licensee will perform routine maintenance and installation of Wireless Facilities in the Electric Space only during daylight hours.
- 4.4 In accordance with Article 6 of the Agreement, in the event Licensor's core business needs necessitate Pole replacement, and Licensor's business needs could have been accomplished by facilities relocation or modification but for the presence of the Licensee's Wireless Facilities, Licensee shall reimburse Licensor a pro-rata share of the Pole replacement costs consistent with the number of existing Licensees sharing in such replacement costs.
- 4.5 Notwithstanding Article 4.4 above, in the event Licensor requires relocation of Licensee Wireless Facilities for its sole need and benefit within two (2) years of licensing such attachment, Licensor shall be responsible for the actual cost of relocating the Wireless Facilities on the Pole or to another Pole owned by

Licensor. Licensor shall have no obligation to reimburse Licensee for relocation costs (i) after 2 years or, (ii) if the Wireless Facilities are removed and not relocated, or (iii) the Wireless Facilities are relocated to a location other than a Licensor owned Pole.

- 4.6 Each Party shall be responsible for its relocation costs associated with Pole replacement resulting from routine Pole maintenance.
- 4.7 Each Party shall be responsible for all costs associated with the relocation of its facilities arising from mandated Pole relocations or modifications ordered by a government or a regulatory agency having appropriate jurisdiction.
- 4.8 Both Parties agree that in the event of wide spread interruptions of Licensor and Licensee Facilities (e.g., a major storm) in connection with damage to the Licensor's Poles, Licensor shall use Good Utility Practice to support restoration of Poles and Licensee's efforts to restore Wireless Facilities, consistent with Licensor's priority obligations to its core electric utility business. In the event of localized interruptions (e.g., motor vehicle accidents), Licensor shall notify Licensee of the incident after taking any required actions to clear and restore the site. Licensee shall reimburse Licensor for all support services provided by Licensor to clear and/or assist in the restoration of Licensee Wireless Facilities.

## **5. SPECIFICATIONS:**

- 5.1 All Licensee Facilities shall be installed and maintained in accordance with applicable nationally codes and standards, Good Utility Practice, applicable Licensor's policies, procedures and standards including GS 1169 (Exhibit 4), and any applicable Federal, State, and Local Laws and Ordinances. All fees, notices, permits, approvals, certifications and licenses, required for the installation, maintenance and operation of Licensee Wireless Facilities, shall be obtained and paid for by Licensee and shall be provided to Licensor at no charge and upon request by Licensor, prior to the start of work.

## **6. INTERFERENCE:**

- 6.1 Licensee will use and operate the Wireless Facilities in a manner that will not cause interference (including, but not limited to, blocking of access to the Pole, radio frequency (RF) interference, mechanical interference or any interference with underground utilities) in Licensor's and other users' use of the Pole, provided that such other users' installation predates the installation of such Wireless Facilities. Licensor agrees to supply Licensee with a list of Licensor licensees on any Pole, which is to be the subject of a license, together with the respective transmission frequencies thereof. In the event any such interference occurs, Licensee will (i) remedy such interference within thirty-six

(36) hours after receipt of written notice from Licensor, conditioned on Licensor's ability to support corrective actions, if required, or (ii) cease operation of its Wireless Facilities until such interference can be eliminated with Licensor's support, if required, and if such interference is not eliminated within said thirty-six (36) hour period, Licensor will have the right, in addition to any other rights that it may have at law or in equity, to take all necessary and reasonable steps, at Licensee's sole cost and expense, to eliminate such interference (after giving reasonable prior notice to Licensee of its intent to do so), and should it be unable to so eliminate such interference, Licensor shall have the right to terminate the license related to the Wireless Facilities causing such interference by giving at least sixty (60) days notice to Licensee, in which case any and all future obligations Licensor may have hereunder (except for the indemnities and hold harmless provisions contained elsewhere in this Agreement) will cease with respect to such terminated license.

- 6.2 Licensor agrees to obtain an agreement with future wireless licensees of the Pole to cease using any equipment, which causes interference to Licensee's or its Sub-licensees' then existing Wireless Facilities. Subsequent to the Installation of Licensee's Wireless Facilities, Licensor will not knowingly permit or suffer the installation or modification by third parties of any other improvement (including, without limitation, transmission or reception antennas or other devices) on the Pole if such improvement could cause or is likely to cause interference (including, but not limited to, blocking of access to the Pole, radio frequency interference, mechanical interference or any interference with underground utilities) with Licensee's then existing Wireless Facilities. In the event any such interference occurs, Licensor shall direct such third party to remedy such interference within thirty-six (36) hours after receipt of notice or cease operation of such improvement until such interference can be eliminated, and if such interference is not eliminated within said thirty-six (36) hour period, Licensor shall take reasonable steps eliminate such interference, including, but not limited to, terminating the occupancy agreement of such third party.
- 6.3 Licensee agrees to provide site-specific radio frequency (RF) emission data and required worker clearances from operational Licensee Wireless Facilities.
- 6.4 Should Licensor, Licensee, or other authorized users require access to the Pole and such access is restrained as a result of Licensor's or Licensee's operational equipment, Licensee and Licensor shall work cooperatively to develop and support access requirements. Work shall be performed in accordance with Licensor safety standards, which may require temporarily ceasing wireless operations to comply with such standards.

## **7. COSTS:**

- 7.1 Licensee shall reimburse Licensor for any and all Costs of services provided by Licensor in support of the design, installation, and maintenance of Licensee's Wireless Facilities. Licensor costs for make-ready surveys, make-ready work and Licensor inspections are to be paid by Licensee in advance of scheduling the field survey, make-ready work or inspections. All survey and make-ready costs that are required by a joint owner or existing third party user(s) in connection with Licensee's Wireless Facilities shall be paid by the Licensee directly to the joint owner(s) or existing third party user(s).
- 7.2 Licensor field surveys, make-ready work and inspection costs are established by unit price, the cost of which shall periodically revised.
- 7.3 All reimbursable Licensor costs shall be invoiced and paid by Licensee prior to the start of work.
- 7.4 In the event Licensor elects to contract Licensor work activities in connection with attachment of Wireless Facilities, the Licensee shall be invoiced to the actual contractor cost plus ten percent (10%).
- 7.5 Payment to Licensor must be received within 30 days of the invoice date. Late fees of 1.5 percent per month will be applied to all outstanding balances in excess of thirty (30) days. Failure to pay such costs by the specified payment date shall constitute a default under the Agreement.

## **8. FEES:**

- 8.1 The annual attachment fee payable to Licensor by Licensee for Wireless Facilities attachments is established in Exhibit 1. Should the Licensor obtain regulatory approval for a revised attachment fee and terms, the Parties agree that the approved attachment fee and terms shall apply in accordance with any such regulatory approval. Attachment fees, if any, owed to the joint owner of the Pole are not included in Exhibit #1 and are subject to separate, independently negotiated terms and conditions. Licensee shall be liable for all attachment related fees owed Licensor's joint owner(s).
- 8.2 The annual attachment fee shall be developed by using the Licensor's annual carrying charge rate, the average net book cost of a bare wood pole at fiscal year end, and the ratio of the occupied space to the total usable space per pole, as determined within NMPC DAS Order, PSC Case No. 03-E-1578. (Reference Exhibit #1 for rate methodology.).
- 8.3 Licensee acknowledges that due to the nature of its attachments the charges established within Exhibit #1 for wireless attachments to Licensor's Poles are

not based on established regulatory formulas for wire-line attachments, but rather in accordance with NMPC DAS Order, PSC Case No. 03-E-1578.

- 8.4 Attachment fees shall be due and payable annually in advance on the July 31st each year. The attachment fee shall commence thirty (30) days after the start of installation of Licensee Facilities or at the completion of installation, whichever is first. First year payments shall be prorated for the remainder of the billing period ending June 30<sup>th</sup>. The attachment fee will be recalculated annually.
- 8.5 Payment to Licensor must be received within thirty (30) days of the invoice date. Late fees of 1.5 percent per month will be applied to all outstanding balances in excess of thirty (30) days. Failure to pay such fees by the specified payment date shall constitute a default under the Agreement.
- 8.6 Electric service for each wireless site shall be metered and billed per the applicable Licensor tariff for electric service.

## 9. INSURANCE

9.1 This article replaces the insurance provisions in Article X of the Pole Attachment Agreement to which this Addendum is attached. Prior to any access to the property, including surveying and the initial installation and during the entire term of this Agreement and any amendments, Licensee and its contractors and subcontractors must procure and maintain insurance in the kinds and amounts listed below:

A. Workers' Compensation Insurance, including Employer's Liability Insurance, as required by New York State. When applicable, coverage shall include The United States Longshoreman's and Harbor Workers' Compensation Act and the Jones Act. Proof of qualification as a self-insurer may be acceptable in lieu of a Workers' Compensation Policy.

B. Comprehensive or Commercial General Liability, including Contractual Liability, and Product/Completed Operations coverage covering all insurable operations required under the provisions of this Agreement and, where applicable, coverage for damage caused by any explosion, collapse or underground peril (XCU), with the following minimum limits of liability:

Bodily Injury Liability	\$5,000,000
Property Damage Liability	\$5,000,000

If a combined single limit is provided, the limit shall not be less than \$5,000,000 per occurrence.

C. Licensor shall be named as an additional insured on the Licensee's liability insurance policy(ies) as respects the activities governed by this Agreement and,

if applicable, each contractor's and subcontractor's policy(ies). In addition, the policy(ies) should include a cross liability endorsement. Licensee shall not be required to name subcontractors as additional insureds on any insurance policy.

D. Automobile Liability covering all owned, non-owned and hired vehicles used in connection with the work or services to be performed under this Agreement with minimum limits of:

Bodily Injury & Property Damage Combined Single limit - \$1,000,000

E. Property Insurance, including coverage for fire, extended coverage, vandalism and malicious mischief, upon the Wireless Facilities. Licensor and Licensee hereby mutually release each other (and their respective successors or assigns) from liability and waive all right of recovery against the other for any loss or damage to their property resulting from the negligent or other unintentional acts or omissions of the other party covered by their respective first party property insurance policies for all perils insured thereunder. In the event of such insured loss, neither party's insurance company shall have a subrogated claim against the other.

- 9.2 Licensee shall furnish bond or other satisfactory evidence of financial security in an amount as Licensor from time to time may require, in an initial amount of \$10,000 for each 100 poles or portion thereof licensed under this Addendum but not exceeding \$50,000 for each 100 poles or portion thereof licensed under this Addendum, to guarantee the payment of any sums which may become due to Licensor for fees due hereunder or charges for work performed for the benefit of Licensee under this Addendum, including the removal of Licensee's Wireless Facilities upon termination of this Addendum or upon termination of any License issued hereunder. The bond or other satisfactory evidence of financial security shall remain in full force and effect until all Wireless Facilities have been removed and all sums due to Licensor have been fully paid. Such bond shall contain a provision that it may not be canceled without 90 days' prior notice to Licensor.
- 9.3 Neither Licensee nor any of its contractors or subcontractors shall commence any work under this Addendum until Licensor has been furnished with the original Pole attachment Bond or other satisfactory evidence of financial security and a completed Certificate(s) of Insurance showing that Licensee and, if applicable, such contractor or subcontractor has complied with this Insurance Article, and that the policies shall not be, diminished or canceled until at least thirty (30) days prior written notice of such, diminishment or cancellation has been given to Licensor. Such certificate of insurance, and any renewals or extensions thereof, shall outline the coverages and limits required, including the amount of deductibles or self-insured retentions which shall be for the account of Licensee, and shall be sent to the following address:



National Grid  
Attn.: Risk Management, Bldg. B-3  
300 Erie Boulevard West  
Syracuse, NY 13202

- 9.4 Licensee represents that it has full policy limits available and shall notify Licensor's Risk Management Department in writing when any coverage required herein has been reduced as a result of claim payments, expenses, or both.
- 9.5 If any insurance coverage is not secured, maintained or is canceled before final payment by Licensee to Licensor and Licensee fails immediately to procure other insurance as specified, Licensor reserves the right to procure such insurance and to add the cost thereof to any sum due Licensor under this Agreement.
- 9.6 Licensee shall promptly furnish Licensor's Risk Management Department with copies of any accident or incident report(s) sent to Licensee's insurance carriers covering accidents/incidents occurring in connection with and/or as a result of the performance of the work under this Agreement.
- 9.7 Nothing contained in these insurance requirements is to be construed as limiting the extent of either Party's responsibility for payment of damages resulting from either Party's use of the property or limiting, diminishing or waiving either Party's obligation to indemnify, defend and save harmless the other as set forth in the indemnification Article included in this Addendum.
- 9.8 It is the intent of both Parties that the liability insurance placed in accordance with the provisions of this Insurance Article shall be primary insurance and shall protect both Licensee and Licensor from losses arising from the performance of this Agreement.

## **10. ACCESS TO THE ELECTRIC SPACE**

- 10.1 Scheduled installation and maintenance of Licensee Facilities - Licensee shall provide written notice to Licensor of all contractors proposed to work within the Electric Space, for its review and acceptance, together with a summary of work to be completed and proposed work schedule, at least ten (10) business days prior to commencement of any installation, maintenance or modification of Licensee Wireless Facilities. No work shall commence until Licensor provides its acceptance of such contractors, summary of work and work schedule.
- 10.2 Emergency maintenance of Licensee Facilities Located in the Electric Space - In the event that Licensee requires emergency access to its facilities located in the Electric Space, Licensee shall provide Licensor prior notice at:

For Licensor

Western Division (716)831-7226 or (716)831-7325

Central Division (315)460-2417 or (315)460-2418

Eastern Division (518)356-6471 or (518)356-6478

These are 24-hour, 7-day per week emergency notification numbers. Calls shall be directed to the Supervisor on Duty, and the caller should be able to provide the following:

1. Name of Company making report;
2. Location reporting problem;
3. Name of contact person reporting problem;
4. Telephone number to call back with progress report;
5. Description of the problem in as much detail as possible;
6. Time and date the problem occurred or began;
7. Proposed corrective actions; and
8. If appropriate, a statement that **“This is an emergency”** and that a problem presents a jeopardy situation to the physical plant of National Grid, Licensee or others as the case may be.

## **11. COMPLIANCE WITH LAWS:**

- 11.1 Licensee shall comply with all applicable Federal, State and local laws, ordinances, rules, regulations, permits, licenses, and requirements thereunder, herein after referred to as “the Laws” in this article, in connection with performance of their activities under this Addendum. Such laws, regulations, etc. shall include, but not be limited to, the current editions and any subsequent revisions of the regulations of the United States Occupational Safety & Health Administration (OSHA), the New York Industrial code, the National Electric Safety Code, and any and all applicable sections of the New York State General obligations Law and the New York State Labor Law.
- 11.2 Licensee shall indemnify and save Licensor harmless from and against any and all direct and indirect costs, expenses, damages and liability resulting from alleged or actual violations of said laws, ordinances, rules, regulations, permits and licenses.
- 11.3 If the Licensee observes that any requirement specified in this Addendum or to the Agreement to which the Addendum is attached, is at variance with any governing laws, ordinances, rules, regulations, permits, or license, Licensee

shall promptly notify Licensor in writing before incurring any further liability, expense, or obligation for the Licensee or the Licensor.

## **12. INDEMNIFICATION:**

12.1 This article replaces the indemnification provisions contained in Article X of the original Agreement.

12.2 Licensee accepts the property in its present condition, as is, where is. To the fullest extent allowed by law, Licensee agrees to indemnify and save harmless Licensor, its officers, employees, agents and assigns from and against any loss, damage, liability, cost, suit, charge, cause of action, claim and expense, arising out of any damage to the property (including environmental damage) or injury to or death of any person as well as from any and all fines, levies, penalties, citations, assessments and fees from any local, state or federal agency, board, court or other governmental authority as a result of any alleged or actual violation of any laws, rules or regulations of such authorities or agencies arising out of, in connection with, or as a consequence of Licensees activities and/or the activities of Licensees agents, servants, employees, contractors or subcontractors, including but not limited to, the use or occupancy (including ingress and egress) of the property, Poles, structures, and right-of-way, and the transmission, installation, operation, use and maintenance of Licensee's Wireless Facilities and property.

12.3 Licensee shall take prompt action to defend and indemnify Licensor against claims, actual or threatened, but in no event later than notice by Licensor to Licensee of the service of a notice, summons, complaint, petition or other service of a process against Licensor alleging damage, injury, liability, or expenses attributed in any way to the Agreement, the Work, or the acts, fault, negligence, equipment, materials, properties, facilities, personnel, or property of the Licensee, it's agents, employees, sub-contractors or suppliers. Licensee shall defend any such claim or threatened claim, including as applicable, engagement of legal counsel, to respond to, defend, settle, or compromise any claim or threatened claim.

12.4 Furthermore, Licensee understands and agrees it is responsible for any and all costs and expenses incurred by Licensor to enforce this indemnification provision.

12.5 The obligations set forth in this article shall survive completion of the work, termination or expiration of this contract.

## **13. LIMITATION OF LIABILITY**

13.1 Regardless of any other provision of this Addendum, and with the exception of any third party bodily injury or third party property damage obligations, under no circumstances will either Party be liable to the other, whether in contract, tort (including negligence and strict liability), warranty, or any other legal theory, for any incidental, indirect, special or consequential damages whatsoever, such as, but not limited to, loss of profits or revenue, cost of capital or of substitute use or performance, interruptions to operations or for claims for damages by or to the other Party's customers. Furthermore, Licensor will not be held liable for the accuracy or integrity of any data or message communicated over Licensee Wireless Facilities.

13.2 In addition, Licensee expressly acknowledges that Licensee Wireless Facilities are exposed to many risks beyond the reasonable control of Licensor, including acts of God or the public enemy, such as but not limited to, wind, rain, sleet, ice, floods, fire, riots, sabotage, expropriation or confiscation of facilities. Except as expressly provided in this Agreement, Licensee shall assume all risk of loss to Licensee Wireless Facilities that may arise in connection with these hazards.

#### **14. MISCELLANEOUS PROVISIONS:**

14.1 Licensee acknowledges that all work, including but not limited to any construction, maintenance or removal activities, to be performed in connection with this Addendum, may pose great hazard to human beings and personal property. Licensee warrants that it will make its employees, agents and contractors aware of these hazards as well as the potential consequences associated with exposure to these hazards. Furthermore, Licensee warrants that it has full responsibility for any and all injury and damages to persons or property resulting from these hazards and any failure by Licensee to advise its employees, agents or contractors as required herein.

14.2 Licensee shall inform each Licensee employee, agent, or contractor working on or about Wireless Facilities, energized or electric supply equipment and the associated lines, of the safety rules governing the employee's conduct while so engaged.

14.4 Licensor shall have the right to remove such Licensee or Licensee contracted employees at Licensor's sole discretion for cause, with notice provided to Licensee upon removal.

14.5 Licensee warrants that all Licensee employees, agents or contractors that work within the Electric Space are Qualified Electric Workers.

14.6 Except as otherwise expressly stated herein, the Parties have no intent, and do not create, any third party rights or interests in this Agreement.

## **15. TERM**

- 15.1 Unless terminated pursuant to Article 16.0, this Addendum shall remain in effect for a term of twenty (20) years from the date hereof and shall extend thereafter until terminated by either party with at least twelve (12) months written notice to the other party.
- 15.2 Termination of this Addendum or any licenses issued hereunder shall not affect Licensee's liabilities and obligations incurred hereunder prior to the effective date of such termination.

## **16. TERMINATION**

- 16.1 Licensor shall have the right to terminate any license issue hereunder, if:
- A. Licensee's Wireless Facilities are installed, operated, used, maintained and/or modified in violation of any law or in aid of any unlawful act or undertaking. Licensor agrees not to terminate any license under this provision for a period of 30 days, provided that Licensee ceases operations at the site and is making diligent efforts to correct the violation(s). Licensee shall provide Licensor with prompt written notice of any such action under which operation or use of the Wireless Facilities is denied, revoked or canceled or reinstated.
  - B. Any authorization which may be required by any federal and/or state governmental and/or regulatory authority with respect to the installation, operation, use, maintenance and/or modification of the Wireless Facilities is denied, revoked or canceled. Licensor agrees not to terminate any license under this provision for a period of 180 days after receipt of notice by the appropriate party, provided that Licensee ceases operations at the site and is making diligent efforts to obtain or reinstate such authorization. Licensee shall provide Licensor with prompt written notice of any such action under which operation or use of the Wireless Facilities is denied, revoked or canceled or reinstated.
- 16.2 Upon termination of any license, neither party will owe any further obligations to the other under such license, except for the indemnities and hold harmless provisions contained throughout this Addendum, Licensee's obligation to reimburse Licensor for all costs, expenses and losses properly incurred by Licensor pursuant to such license and Licensee's obligations under Section 15.4.
- 16.3 In the event of termination of this Addendum, Licensee shall within sixty (60) days from the date of termination submit a plan and schedule to Licensor under which Licensee will remove, or have its Wireless Facilities removed, within twelve (12) months from date of termination from Licensor's Poles; provided

however, that Licensee shall be liable for and pay all fees pursuant to the terms of this Addendum to Licensor until Licensee's Wireless Facilities are removed. In the event that Licensee fails to vacate the Pole or fails to remove all of its Wireless Facilities, Licensor shall have the right, after giving at least ten (10) days prior written notice to Licensee, to remove the remaining Wireless Facilities, in which event such Wireless Facilities may be retained by Licensor as its property without accounting to Licensee therefore, and the expense of such removal and repairs shall be charged to and paid by Licensee without credit for the value, if any, of such Wireless Facilities.

## **17. TAXES & CHARGES**

17.1 Licensee shall pay all annual or periodic real property, personal property, gross receipts, franchise tax or other taxes, including any increase in such taxes levied or assessed to Licensor and based upon the license granted by this addendum or on account of its existence and shall indemnify, defend and hold harmless Licensor against the payment thereof. Licensor will provide reasonable notice to Licensee of receipt of notice of assessment of property or any portion thereof, which includes an increment of such assessment attributable to the license. Licensor shall bill for the payment of such taxes attributable to the license and Licensee will pay in accordance with Licensor real estate tax policies and procedures. In the event Licensor wishes to challenge any assessments on property that is subject to the license, Licensor will conduct such challenges and Licensee agrees to provide reasonable cooperation. In the event Licensee wishes to challenge an assessment or increase thereof related to the license, Licensee shall request Licensor to conduct such challenge and Licensor agrees to provide reasonable cooperation in conducting such challenges. Licensee shall pay all expenses incurred by Licensor in connection with conducting such challenges including but not limited to reasonable attorney's fees, expert witness fees and disbursements. To the extent any of the above taxes relating to the license are levied and assessed directly to Licensee, Licensee shall be responsible for any filings, timely payment of and any challenges to such taxes and Licensor agrees to provide reasonable cooperation in relation to same.

## **18. ASSIGNMENT**

18.1 Licensee shall not assign or transfer this Addendum or any authorization granted hereunder, and this Addendum shall not inure to the benefit of Licensee's successors, without the prior written consent of Licensor, which shall not be unreasonably delayed or withheld.

18.2 In the event such consent or consents are granted by Licensor, then this Addendum shall extend to and bind the successors and assigns of the parties hereto.

18.3 Pole space licensed hereunder is for Licensee's use only, and Licensee shall not lease, sublicense, share with, convey or resell to others any such space or rights granted hereunder, except that Licensee may, (i) allow equipment of others to be placed within cabinets or boxes of Licensee placed on Poles of Licensor, or (ii) allow equipment of others to be placed on Poles of Licensor below the lowest communications cable on such Pole. If Licensee allows the placement of equipment of others within cabinets or boxes of Licensee placed on Poles of Licensor, Licensee's responsibilities under this Addendum shall be, in all respects, as though such equipment belonged to Licensee.

## **19. PROTECTION AGAINST LIENS ON PROPERTY**

Licensee will keep the property free from any liens arising out of any work performed, materials furnished or obligations incurred by or on behalf of Licensee and shall indemnify, defend and hold harmless Licensor from all claims, demands, costs and liabilities, including reasonable attorney's fees and costs, in connection with or arising out of any such lien or claim of lien. Licensee will cause any such lien imposed on the property to be released of record by payment or posting of a proper bond within forty-five (45) days after receipt by Licensee of notice of the filing of such lien.

## **20. NOTICES**

All notices, requests, demands and other communications hereunder will be in writing and will be deemed given if personally delivered, sent by facsimile or by an overnight courier provided proof of service is furnished therefore, or if mailed, certified mail, return receipt requested, to the parties at the following addresses:

If to Licensor:

National Grid  
300 Erie Boulevard West  
Syracuse, NY 13202  
Attn: Director – Energy Delivery Services  
(315) 428-6404

with a copy to:

National Grid  
300 Erie Boulevard West  
Syracuse, NY 13202  
Attn: Law Dept.  
(315) 428-3310

If to Licensee:

---

---

---

---

## **21. PUBLIC SERVICE COMMISSION APPROVAL**

The Parties acknowledge that this Addendum and any amendments thereto may be filed with and may require the approval of the New York Public Service Commission ("PSC") or that Licensor may seek approval of same from the PSC. If the PSC issues any rule, order or determination that directly or indirectly prohibits or prevents performance under this Addendum or otherwise makes such performance illegal or impossible, or takes any action or issues any rule, order or determination that directly or indirectly effects a material adverse change in any substantive provision of this Addendum, in the terms of performance or the rights or obligations of either party, then either party may (i) proceed with the Addendum so changed, (ii) seek to renegotiate the affected terms of the Addendum by providing written notice to the other party of its desire to do so or (iii) terminate the Addendum by providing sixty (60) days' prior written notice; provided that, if such action or determination is rescinded prior to the effectiveness of such termination notice, the termination notice will be ineffective.



**IN WITNESS WHEREOF**, the parties have caused this Addendum to be duly executed as of the day and year first written above.

**NIAGARA MOHAWK POWER CORPORATION (LICENSOR):**

By: \_\_\_\_\_

Title: \_\_\_\_\_

Date: \_\_\_\_\_

\_\_\_\_\_ **(LICENSEE)**

By: \_\_\_\_\_

Title: \_\_\_\_\_

Date: \_\_\_\_\_

**EXHIBITS:**

- Exhibit 1      Wireless Facilities Fee Schedule
- Exhibit 2      Licensor Construction Services Agreement
- Exhibit 3      Proposed Wireless Facilities
- Exhibit 4      Licensor Standard GS 1169 (Wireless Attachments to Wood Poles)
- Exhibit 5      Procedure for Processing Multiple Applications

Wireless Attachments to  
Niagara Mohawk Wood Poles  
Fee Schedule

Effective Annual Attachment Rate	Solely-Owned Poles Attachment Fee <sup>2</sup> (\$/pole/yr)
Effective 04/13/04	\$59.84

Annual Attachment Fee Methodology:

Note: For Attachment Fee calculations, the antenna is assigned 2ft of pole space and the accessory panels are assigned 5ft of pole space

Attachment Fee = [A x B x E]

(A) - Licensor annual carrying charge [47.34%]

(B) - Licensor net cost of bare pole adjusted for appurtenances not usable  
[\$334.05]

(C) - Usable pole space [l = 13.5 + 5 = 18.5ft]

(D) - Occupied Space [2 ft. at top of pole + 5 ft. accessory panel space = 7 ft. Total Occupied Space]

(E) - Percentage of Occupied to Usable Space [D/C = 37.84%]

---

<sup>2</sup> Attachment Rate per NMPC DAS Order, PSC Case No. 03-E-1578, p. 4). This rate is further reflected in the latest Tariff 207 at Rule 35.2.2.1. The Attachment Fee shall be adjusted for jointly owned poles in accordance with the Licensor's pole ownership interest.

Attachment C, Item 3

# DAMAGE FROM LIGHTNING TO PCS TOWER EQUIPMENT IS \$150 M A YEAR AND LIGHTNING IS UPON US AGAIN

## 200 PLUS FOOT TOWERS HAVE THE PROBABILITY OF BEING HIT ONCE IN A LIGHTNING SEASON IN MOST OF THE COUNTRY

Distribution Source : ArriveNet

Date : Friday, April 07, 2006

Sedalia, CO -- (ArriveNet - Apr 07, 2006) -- by Ernest M. Duckworth Jr., P.E.

President-LPGI & Affiliates

962 Coronado Drive

Sedalia, CO 80135

303-688-5800

Why are these tower locations so susceptible to lightning-induced damage? There are two reasons: (1) most antenna sites are not correctly grounded to properly conduct light strike energy, because no code demands it, and (2) very rarely do wire-line communication service providers install isolation equipment to protect communications services from a lightning induced Ground Potential Rise (GPR), also because no code demands it.

Why aren't antenna sites properly grounded to protect against lightning strike energy? Because the National Electrical Code (NEC) is the controlling code for grounding, and it does not address lightning strike energy, only electrical supply energy!

ADVERTISEMENT

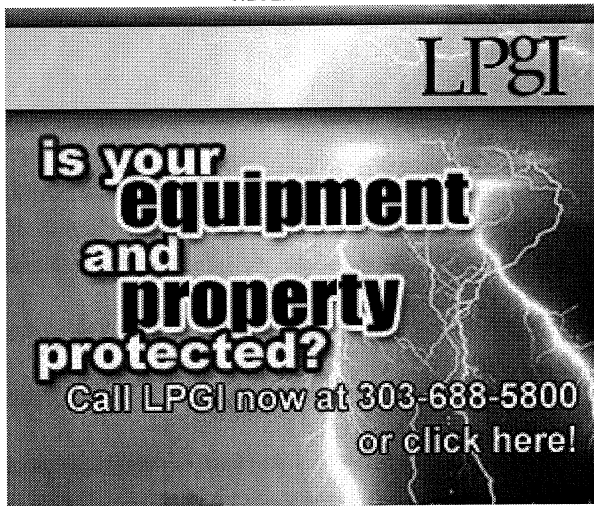

Section 810-2 of the NEC, Grounding Conductors, describes how to ground an antenna with a single ground rod and a #6 gauge wire to insure the safety of personnel in case the antenna should become electrically energized from contact with the electric power system. This method of grounding is completely inadequate to dispose of an average 30,000 Ampere lightning strike and resulting Ground Potential Rise. This method of grounding for lightning strike energy is as effective as trying to use a one inch diameter pipe, five miles long to supply water to all of New York City!

Two solutions to properly protect against lightning induced GPR at antenna sites; i.e., current division grounding and isolation of communications lines can be met with relatively little extra cost. In fact, these additional costs are minuscule when compared to the total site construction cost and the costs of ongoing GPR damage repair.

Instead of providing a single ground rod and a #6 gauge wire from one of the tower legs, it is far superior to install a star grounding system that will divide the current from a lightning strike into smaller segments.

Instead of providing gas tubes on the wire-line communications services entering the antenna building, install isolation equipment on all entering pairs. This will isolate all wire-line services from remote ground in the event of a lightning induced GPR and thus protect all associated equipment from damage.

Thus, for less than 1% of the site construction budget you can effectively eliminate all future communication equipment damage from lightning strike energy. The average damage resulting from the first lightning strike on an improperly protected antenna site is approximately \$25,000.

LPGI & Affiliates designs grounding systems to prevent equipment damage from lightning's resulting Ground Potential Rise. These grounding systems are less than 2 ohms and are capacitively coupled to the earth using radials and conductive cement.

Call us at 303-688-5800. We can help prevent damage from that next lightning strike to your tower.

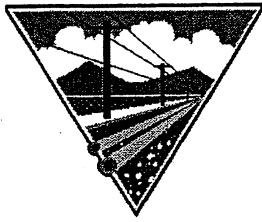

*Attachment C, Item 4*

# Oregon Utility Safety Committee

(Sponsored by the Oregon Public Utility Commission)

**Mission Statement:** To bring utilities and state agencies together in a non-adversarial, cooperative effort to promote positive safety and health practices for both the public and the worker.

---

## AGENDA

**Date:** Friday, November 17, 2000

**Time:** 9 a.m. to 12 Noon

**Location:** Portland General Electric Company  
Salem Service Center Conference Room  
4242 Kale Street NE  
Salem, Oregon 97305

- Agenda:**
1. Introductions – New Members and Guests
  2. Utility Accident Reports
  3. Report on Eastern Oregon Utility Safety Committee Meeting
  4. Old Business
  5. New Business
    - Election of Officers
    - PUC Staff Revised Inspection Policy – Jerry Murray
  6. Utility Interaction and Coffee Break

*See following  
pages -  
Showing  
QWEST (SUSWEST)  
Procedures*

**Program:** High Voltage Safety Concerns Associated with Power Substations  
Speaker: Tim Concer, Qwest

*⊕ Tower Antennas*

---

**Officers:** Jim Wilber, President  
Beaver Creek Cooperative Telephone Co., phone (503) 632-3113

George Normine, Secretary  
Portland General Electric, phone (503) 736-5471

Jerry Murray, PUC Representative, phone (503) 378-6626  
Judy Ogilvie, PUC Administrative Contact, phone (503) 378-5763

**Next Meeting:** Friday, December 15, 2000 - La Grande  
Friday, January 19, 2001 - Salem



**U S WEST EMPLOYEES FOLLOW  
THESE SAFETY PROCEDURES  
WHEN WORKING AT THIS  
LOCATION:**

- **STAND ON RUBBER BLANKET**
- **USE RUBBER GLOVES OR INSULATING TOOLS**
- **WEAR SAFETY GLASSES AND HARDHAT**

*Attachment C, Item 4*

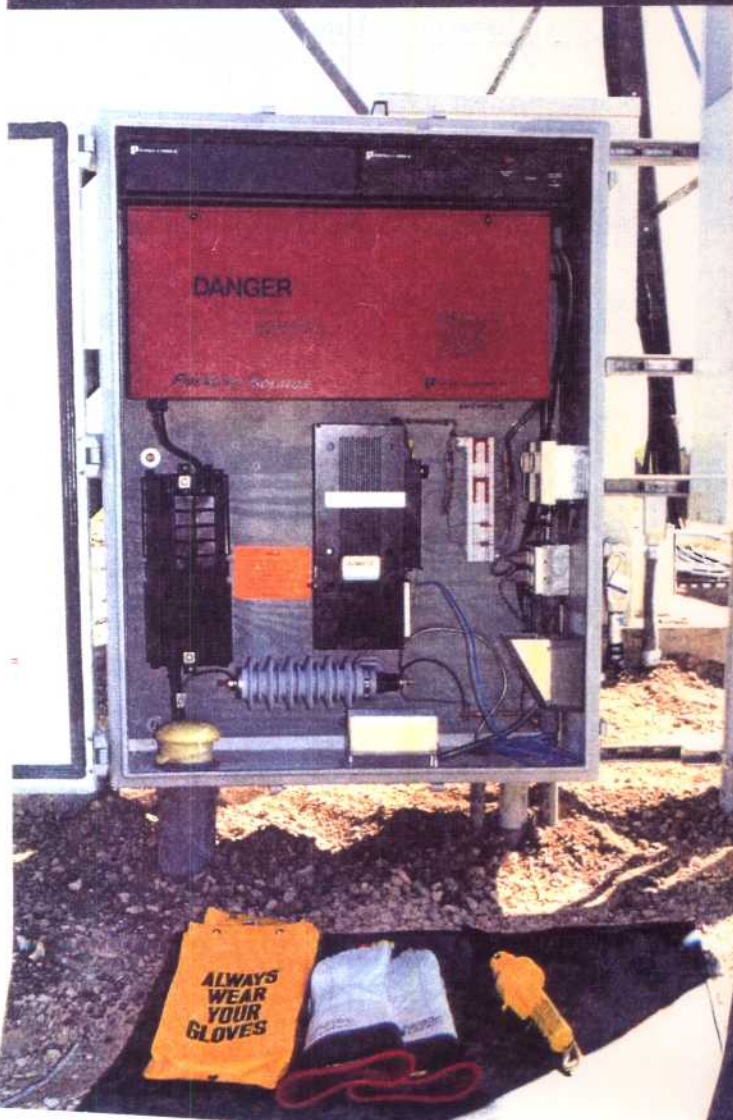
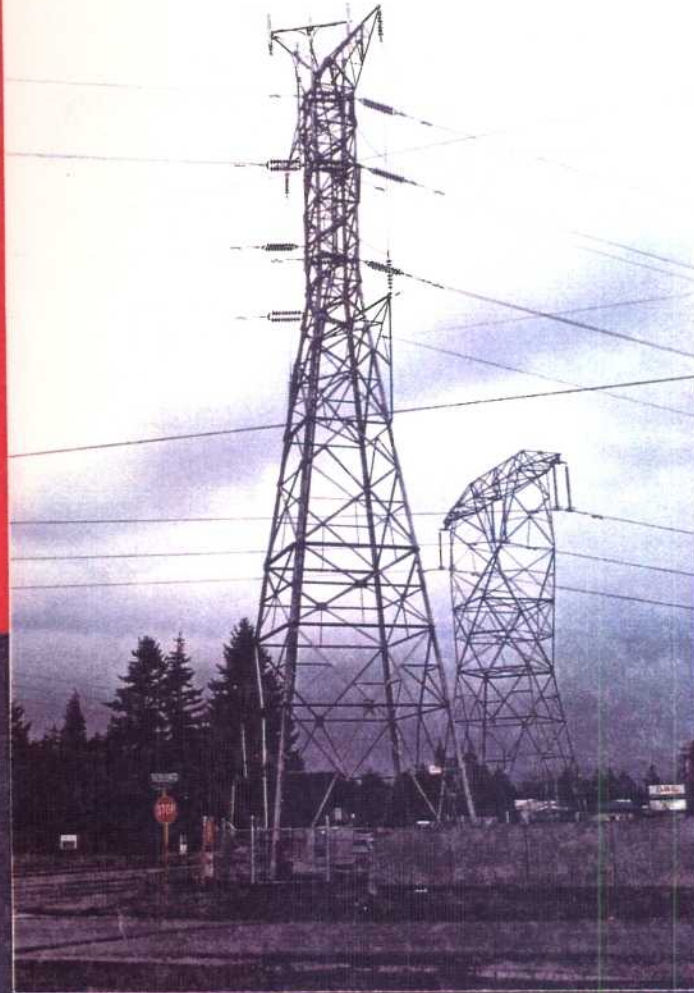

**CAUTION: HIGH VOLTAGES  
MAY APPEAR WITHOUT  
WARNING**

**USWEST**

Tim Conser  
TEC - 55 Consultant  
Technical Support - NROC

U S WEST Communications  
700 W. Mineral Ave. Room MT G22.31  
Littleton, CO 80120  
Phone 303 707-5616  
FAX 303 707-9041  
Pager 800 759-7243 Pin # 3034896  
E-Mail [tconser@uswest.com](mailto:tconser@uswest.com)

Recognized as an  
American National Standard

**IEEE Std 367-1996**  
(Revision of IEEE Std 367-1987)

# **IEEE Recommended Practice for Determining the Electric Power Station Ground Potential Rise and Induced Voltage From a Power Fault**

Co-Sponsors

**Power Systems Communications Committee  
of the  
IEEE Power Engineering Society**

and the

**Transmission and Access Systems Committee  
of the  
IEEE Communications Society**

Approved 16 September 1996

**IEEE Standards Board**

Approved 6 February 1997

**American National Standards Institute**

**Abstract:** Guidance for the calculation of power station ground potential rise (GPR) and longitudinal induction (LI) voltages is provided, as well as guidance for their appropriate reduction from worst-case values, for use in metallic telecommunication protection design.

**Keywords:** electric power stations, ground potential rise, induced voltage, longitudinal induction voltages, power faults, power stations, telecommunication protection design, telecommunications

---

The Institute of Electrical and Electronics Engineers, Inc.  
345 East 47th Street, New York, NY 10017-2394, USA

Copyright © 1997 by the Institute of Electrical and Electronics Engineers, Inc.  
All rights reserved. Published 1997. Printed in the United States of America.

ISBN 1-55937-886-7

*No part of this publication may be reproduced in any form, in an electronic retrieval system or otherwise, without the prior written permission of the publisher.*

# **IEEE Recommended Practice for the Protection of Wire-Line Communication Facilities Serving Electric Power Stations**

Sponsor  
**Power Systems Communications Committee  
of the  
IEEE Power Engineering Society**

Approved March 19, 1992  
**IEEE Standards Board**

**Abstract:** Workable methods for protecting wire-line communication circuits entering power stations are presented. This document covers: the electric power station environment; protection apparatus; services types, reliability, service performance objective classifications, and transmission considerations; protection theory and philosophy; protection configurations; installation and inspection; and safety.

**Keywords:** wire-line communication, protection.

The Institute of Electrical and Electronics Engineers, Inc.  
345 East 47th Street, New York, NY 10017-2394, USA

Copyright © 1992 by the  
Institute of Electrical and Electronics Engineers, Inc.  
All rights reserved. Published 1992  
Printed in the United States of America

ISBN 1-55937-219-2

*No part of this publication may be reproduced in any form,  
in an electronic retrieval system or other wise,  
without the prior written permission of the publisher.*



### **Power Induction**

Disturbances from magnetic power induction can occur wherever telephone and power lines run parallel for long distances. Plant subject to power induction of more than 300 volts (rms) to ground is considered to be exposed. Although lower voltages may exist as a result of unbalanced power line operation, induced voltages exceeding 300 volts (rms) to ground are most likely to be caused by power line faults.

### **Ground Potential Rise**

Plant subject to a ground potential rise of more than 300 volts (rms) to ground is considered to be exposed. The danger of a ground potential rise is greatest in the vicinity of a power generating station or a substation. Ground potential rises can develop between the power station ground and remote grounds from a fault anywhere in the power network, and the situation may persist until the fault is cleared. See box on this page.

### **Unexposed Plant**

Where none of the above conditions for exposed plant exist, the plant is considered unexposed.

#### **IMPORTANT**

#### **SPECIAL PROTECTION IN THE VICINITY OF POWER STATIONS**

The plant serving power generating stations, substations, and switchyards requires special protection methods. The hostile electrical environment during power fault conditions often requires that special protection measures be applied at the power station, a remote drainage location, and the central office. In addition, special protection may be required to prevent damage to cables in close proximity to the power station. Unless the measures outlined in AT&T 876-310-100 are applied, service interruptions, plant damage, and personnel hazards may result. Non-dielectric fiber optic cables have the same problems that metallic cables have to dissipate foreign potentials.

## **Technical Publication**

U S WEST Communications has created a document that will assist in determining the appropriate High Voltage Protection (HVP).

The Document is Reference Publication **77321**,  
Special High Voltage Protection.

Customers wishing to receive the publication should contact:

**Faison Office Products Company**  
**3251 Revere Street Suite # 200**  
**Aurora, Colorado 80011**

**Phone (800) 777-3672 toll free**

**(303) 340-3672 local**

**(303) 340-1905 fax**

**1.00 GENERAL**

1.01 This document describes telecommunications services provided by U S WEST that extend into high voltage environments. Services that enter high voltage environments may require special protection. This Special High Voltage Protection as designed by U S WEST will provide personnel and equipment safety while insuring the continuity of service. The provision of these services generally follows the recommendations of ANSI/IEEE STD. 487, "IEEE Guide for the Protection of Wire-Line Communication Facilities Serving Electric Power Stations."

**2.00 PURPOSE**

2.01 The purpose of this document is to describe services provided on facilities that extend into high voltage environments, i.e., electric power generating, switching and distributing locations. These services require high voltage protection whenever hazardous voltages of 1000V peak-asymmetrical or greater appear on those facilities due to Ground Potential Rise (GPR) and/or induction caused by faults in the customer's electric power system. Special High Voltage Protection is designed to isolate or neutralize hazardous voltages. The protection objectives on U S WEST services and facilities at these locations are as follows:

- A. To minimize electrical hazards to personnel engaged in construction, operation, maintenance and use of telecommunications services.
- B. To limit electrical damage to telecommunications equipment, cable and wire facilities.
- C. To provide the required service continuity and integrity of telecommunication transmission as specified by the customer with the approval of U S WEST.

2.02 This offering requires Special High Voltage Protection at the customer's premises and at the U S WEST Central Office whenever the fault-produced GPR/induction equals or exceeds 1000V peak-asymmetrical.

**3.00 RESPONSIBILITY OF U S WEST**

3.01 U S WEST, working in conjunction with the customer, shall determine the proper methods of protection required to achieve the objectives set forth in Section 2.00. The method of protection for every service in a cable shall be coordinated by U S WEST to be compatible with the protection provided for the most critically important service in that cable.

3.02 It is expressly declared that metallic facilities are in continually decreasing supply, and U S WEST is not obligated to continue to make such facilities available. Metallic facilities are offered only where existing facilities and operating conditions permit.

3.03 U S WEST reserves the right to treat Special High Voltage Protection on an individual case basis, dependent on the type of facilities available.

3.04 U S WEST reserves the right to suspend any service without adequate Special High Voltage Protection until adequate protection is provided.

**4.00 RESPONSIBILITY OF THE CUSTOMER**

**4.01** The customer shall be responsible for providing to U S WEST a completed Form RG31-0048, "Design Information for Power Industry Channels," (see Exhibits A, B and C on Pages 8-10) which includes the following:

- A.** Exhibit A is the front of Form RG31-0048 with numbered blocks used for directions on how it is to be completed.
- B.** Exhibit B is the back of Form RG31-0048 which identifies service types and performance objectives.
- C.** Exhibit C is the instructions for filling out Form RG31-0048 using Exhibit A.

**4.02** Changes in the information provided in paragraph 4.01 will require written notification, along with a revised Form RG31-0048. These changes shall be provided as they occur to permit reevaluation and redesign of the existing high voltage protection.

**5.00 PROTECTION SERVICE TYPES**

**5.01** Protection services which U S WEST offers are identified according to the following types:

- A.** Type 1 - Services requiring either dc transmission or ac and dc transmission, used for Basic Exchange Telephone Service and/or Private Line Access Service.
- B.** Type 2 - Private Line Access Service requiring (ac/dc) Voiceband or (dc) Narrowband transmission, used for pilot wire protective relaying or (dc) tripping respectively.
- C.** Type 3 - Private Line Access Service requiring (ac) Voiceband/Data transmission only, used for telemetering, supervisory control, data, etc.
- D.** Type 4 - Private Line Access Service requiring (ac) Voiceband transmission only, used for audio tone protective relaying.

**6.00 SERVICE PERFORMANCE OBJECTIVE CLASSIFICATIONS**

**6.01** Interruptions for outages of telecommunications circuits serving electric power substations may occur for physical reasons such as cable damage due to extraordinary heavy storm loading, a vehicle striking and breaking a utility pole, a cable cut, a lightning strike, or any other natural disaster. Circuit failures caused by such events cannot be prevented and U S WEST expressly states that provision of the service provided in this section cannot preclude such service outages as many occur due to the above mentioned circumstances.

**6.02** Interruptions or outages due to the effects (Ground Potential Rise and/or induction) of faults in the customer's power generating, transmission and/or distribution systems are minimized through the installation and maintenance of high voltage protection service which is designed to operate in a fault-produced electrical environment.

- 6.03 Service Performance Objective Classifications have been established for the purpose of permitting the customer to specify the performance objectives for most types of telecommunications services provided to power stations. Service Performance Objective Classifications are offered to provide various degrees of service continuity during power system faults.**
- A. Class A - Non-interruptible service performance (must function before, during and after the power fault condition) for services requiring ac transmission only. Class A service cannot tolerate even a momentary service interruption. Non-tolerable service interruptions include both loss of dependability (failure to deliver a valid trip or control signal) and loss of security (delivery of a false trip or control signal).**
  - B. Class B - Self-restoring interruptible service performance (must function before and after the power fault condition) for any service. Class B service can tolerate a service interruption for the duration of a power system fault but service continuity must be restored immediately after the fault without requiring any repair personnel activity.**
  - C. Class C - Normal service which does not require Special High Voltage Protection. Interruptible service performance (can tolerate a station visit to restore service) for power stations with a GPR less than 1000V peak-asymmetrical. Class C service cannot be provided in conjunction with Class A or Class B service.**

CUSTOMER  
RESPONSIBILITIES

It is the responsibility of the customer to provide the Company with the following information:

- service locations
- Ground Potential Rise (GPR) fault data
- service type
- service classification
- HVP service option
- proposed terminal equipment
- channel type (e.g., FD type circuit)
- complete Form RG31-0048 "Design Information for Power Industry Channels"

NOTE: When one customer extends a circuit to a high voltage environment which belongs to another customer (e.g., a governmental agency terminating at an electric company's power plant), installation personnel may discuss the need for HVP with either customer. The customers must discuss HVP requirements with each other in order to provide complete information to the Telephone Company. HVP is only effective if all services terminating at a customer location are protected. One customer's delayed installation of HVP may impact installation of other customers' services

Anytime a customer wishes to change any of the above information, a revised RG31-0048 is required.

CUSTOMER  
RESPONSIBILITIES  
(CONT)

See Attachment 2 - Form RG31-0048.

ORIGINATOR  
RESPONSIBILITIES

The originator is responsible for:

- determining HVP service option
- mailing Form RG31-0048 to the customer

NOTE: The form is sent to the customer upon request and can be ordered through normal ordering procedures

- following up for receipt of Form RG31-0048 completed by the customer
- reviewing returned Form RG31-0048 for completeness
- sending completed Form RG31-0048 to the appropriate Electrical Protection Engineer.

NOTE: The engineer will call the originator within two business days to advise of HVP USOCs. A copy of the RG31-0048 will then be returned to the originator to be filed. The original RG31-0048 is retained by the HVP Engineer. If the high voltage environment is located in another Exchange Carrier's serving territory, the originator must forward the form to the appropriate Exchange Carrier Service Bureau

- Notifying the customer of the due date
- issuing the service order



RG31-0048  
(4-88)

**DESIGN INFORMATION FOR POWER INDUSTRY CHANNELS**  
**CUSTOMER INFORMATION**

(Use one form for each service order requested. See item Service Classification.)

Pg \_\_\_\_ of \_\_\_\_

CUSTOMER 1		
LOCATION A - STATION NAME 2	ADDRESS 3	TEL. NO. 4
LOCATION B - STATION NAME 5	ADDRESS	TEL. NO.

**GROUND POTENTIAL RISE (GPR) FAULT DATA**

FAULT CIRCUIT X/R RATIO	EARTH RETURN FAULT CURRENT (RMS)	GRID IMPEDANCE	GRID AREA	GROUND POTENTIAL RISE (RMS)
LOCATION A 6	AMPS 7	OHMS 8	SQ. FT. 9	VOLTS 10
LOCATION B 5	AMPS	OHMS	SQ. FT.	VOLTS

**SERVICE CLASSIFICATION** (Definitions of type, Class and USOC are on reverse of this sheet. If Class C is requested leave Class item blank.)

LOCATION A	TYPE	CLASS	USOC	
11	12	13	14	
LOCATION B 5	TYPE	CLASS	USOC	

**PROPOSED TERMINAL EQUIPMENT**

MAKE 15	MODEL 15	FACILITIES INTERFACE CODE 16
------------	-------------	---------------------------------

CHANNEL TYPE (Existing Service - New Request - Future Needs)	EXISTING	NEW	FUTURE
<input type="checkbox"/> 2 W PHONE, 2 W TRUNK, DC CIRCUITS, ISDN (Type 1 Service)	18	19	20
<input type="checkbox"/> TIE LINE, TRUNK, RADIO REMOTE, ETC. (Type 1 Service)			
<input type="checkbox"/> 2 WIRE <input type="checkbox"/> 4 WIRE			
<input type="checkbox"/> DIGITAL DATA SERVICE (Type 1 Service)			
<input type="checkbox"/> PILOT WIRE RELAY (Type 2 Service)			
<input type="checkbox"/> D.C. TRIPPING (Type 2 Service)			
<input type="checkbox"/> A.C. TONES W/O SIGNALING AND HIGH CAPACITY DIGITAL (DS1)			
<input type="checkbox"/> TELEMETERING, SCADA DATA (Type 3 Service)			
<input type="checkbox"/> HIGH CAPACITY DIGITAL (DS1) (Type 3 Service)			
<input type="checkbox"/> AUDIO TONE PROTECTIVE RELAYING (Type 4 Service)			

**ENGINEER OR REPRESENTATIVE** (Must have attached sketch of the power station showing present and future power transmission routes.)

SIGNATURE 21	DATE	TEL NO ( )	ADDRESS
-----------------	------	---------------	---------

**TELEPHONE COMPANY INFORMATION**

SERVICE ORDER NO.	DUE DATE	CIRCUIT NUMBER	SPECIAL BILLING NO.
ACCOUNT REPRESENTATIVE	TEL NO ( )	SEND TO ELECTRICAL PROTECTION ENGINEER	
ELECTRICAL PROTECTION ENGINEER - SIGNATURE	DATE	TEL NO ( )	ADDRESS
PROTECTION REQUIRED	300 V pk POINT DISTANCE (FT)	USOC	TYPE
	LOCATION A		QUANTITY
LOCATION B			
LOOP FACILITY DESIGNER	TELEPHONE NUMBER ( )		JOB NUMBER



DEFINITIONS

CLASS A OR B SERVICE

SERVICE TYPE AND PERFORMANCE OBJECTIVE CLASSIFICATION / USOC\*

TYPE ① CLASS B SERVICE (Phone, Tie Lines, Trunks, Radio Control, DC Alarms, Telegraph and DDS).  
 ↳ All circuits used for talking plus DC telemetering and telegraph.  
 ↳ Services which require both AC and/or DC transmission and which can tolerate momentary interruptions during a power fault. (Must function before and after a power fault.)

	<u>USOC</u>
2 Wire	HVC
#4 Wire	HVA
4 Wire	HVD

TYPE ② CLASS B SERVICE (D.C. Tripping, Pilot Wire Relay)(Class A performance not available).  
 ↳ Normally a metallic cable pair end to end, but it can be a DC telegraph channel. (Metallic facilities are offered only where existing facilities and operating conditions permit).  
 ↳ Services which require both AC and DC transmission and which can tolerate momentary interruptions during a power fault. (Must function before and after a power fault.)

2 Wire	HVE
#4 Wire	HVB

TYPE ③ CLASS A SERVICE (Data, Telemetering, SCADA)  
 ↳ Critical non type 4 circuits which require class A performance  
 ↳ Services for AC transmission only which cannot tolerate even momentary interruption. (Must function before, during and after a power fault.)

2 Wire	HVF
4 Wire	HVG

TYPE ③ CLASS B SERVICE (Data, Telemetering, SCADA)  
 ↳ All tone signals 300 HZ to 5 MHZ and High Capacity Digital (DS1 Rate)  
 ↳ Services for AC transmission only which can tolerate momentary interruptions during a power fault. (Must function before and after a power fault.)

2 Wire	HVH
4 Wire	HVJ

TYPE ④ CLASS A SERVICE (Audio Tone Protective Relaying)  
 ↳ Protective Relaying or Transfer Trip only. (Voice Grade 12 when interlata)  
 ↳ Services for AC transmission only which cannot tolerate even momentary interruption. (Must function before, during and after a power fault.)

2 Wire	HVK
4 Wire	HVL

#Services limited to a maximum ground potential rise (GPR) of 4.0 KV RMS-11 VS. (Refer to Electrical Protection Engineer before selecting.)

CLASS C SERVICE

Interruptible service performance (can tolerate visit to restore service).

If ground potential rise (GPR) is less than 1000 volts peak-asymmetric, no protection is required and Class C service may be requested. This shall be determined by Electrical Protection Engineer.

\*TYPE of service refers to circuit usage.  
 CLASS of service refers to reliability of HVP during a power fault.

## INSTRUCTIONS FOR FORM RG31-0048

1. Customer Name
2. Power station name
3. Power station address
4. Power station phone number
5. Other end of requested service if applicable. Use additional forms for multipoint circuit locations.
6. X/R (inductive reactance to resistance) ratio for the worst case fault current.
7. Worst case return fault current passing through the grid resulting in a Ground Potential Rise (GPR).
8. Grid impedance in relation to remote earth.
9. Area covered by station ground grid in square feet.
10. Ground Potential Rise (GPR) in rms volts.
11. Type of service requested. See note on back of form.
12. Class of service performance objective requested. See note on back of form.
13. USOC is determined by Type/Class of service and whether 2 or 4 wire. See back of form.
14. (Optional) The distance from the edge of the grid to the 300 volt point calculated from field tests.
15. Enter information on connecting terminal equipment.
16. Facilities Interface Code. (When required by the service order.)
17. Check appropriate boxes for requested service.
18. Existing number of services of each type now at the location.
19. Number of services of each type marked being requested.
20. Projected future services of each type expected at this location. This and items 18 and 19 are needed when a new entrance facility or High Voltage Protection upgrade is required.
21. A signature and date is required from the engineer providing the information or a representative of the company requesting the service. Include telephone number and address of that person.
22. Make no entries in this area.



**Donald E. Goff**  
**TEC 55 Consultant - Electrical Protection**  
700 W. Mineral Avenue, Mail Stop MT H22.01  
Littleton, Colorado 80120

**Phone (303)707-5615**  
**FAX (303) 707-9041**  
**Page (800) 759-7243,**  
**PIN 289 2977**

January 12, 1998

**Memorandum to File:**

Form RG31-0048, "Design Information for Power Industry Channels", is a form designed to communicate the electrical characteristics of an electrical power location to U S WEST. This information enables U S WEST to design communications circuits into the power location in accordance with ANSI/IEEE 367, Recommended Practice For Determining The Electric Power Station Ground Potential Rise And Induced Voltage From A Power Fault and ANSI/IEEE 487, Guide For The Protection Of Wire-Line Communications Facilities Serving Electric Power Stations. Power utility customers routinely submit this form as part of the ordering process.

U S WEST Reference Publication 77321, "Special High Voltage Protection", was written as a guide for U S WEST employees, U S WEST customers, and U S WEST suppliers, to detail the process used by the Company in dealing with requests for service in these locations.

As a result of questions raised by Wireless PCS providers, we have studied the Reference Publication, the Business and Government Services' "BIG" book (Products and Services - High Voltage Protection), and the tariff governing our interaction with Wireless PCS companies (FCC 5 - Protection Service for High Voltage Environments, 13.3.16). Those publications, taken together, mandate that a Form RG31-0048 be submitted for each location for which service is requested.

The only alternative available is a letter, on letterhead and appropriately signed, from the power utility owner, stating that at no time will the Ground Potential Rise (GPR) at the site or sites ever exceed 1,000 Volts Peak-Asymmetrical, as calculated per ANSI/IEEE 367. The power utility owner must be made aware that issuance of the letter constitutes an assumption of liability for injury and/or damage brought about by electrical fault conditions.

Each site will be analyzed on its individual merits, and a design produced to protect the transmitter site from the hazards in the power location. The electrical limits are described in the publications previously cited.

If there are any questions, please contact me at (303) 707-5615 or Tim Conser at (303) 707-5616.

Person becomes part of the current path during fault conditions when communications services are not properly isolated.

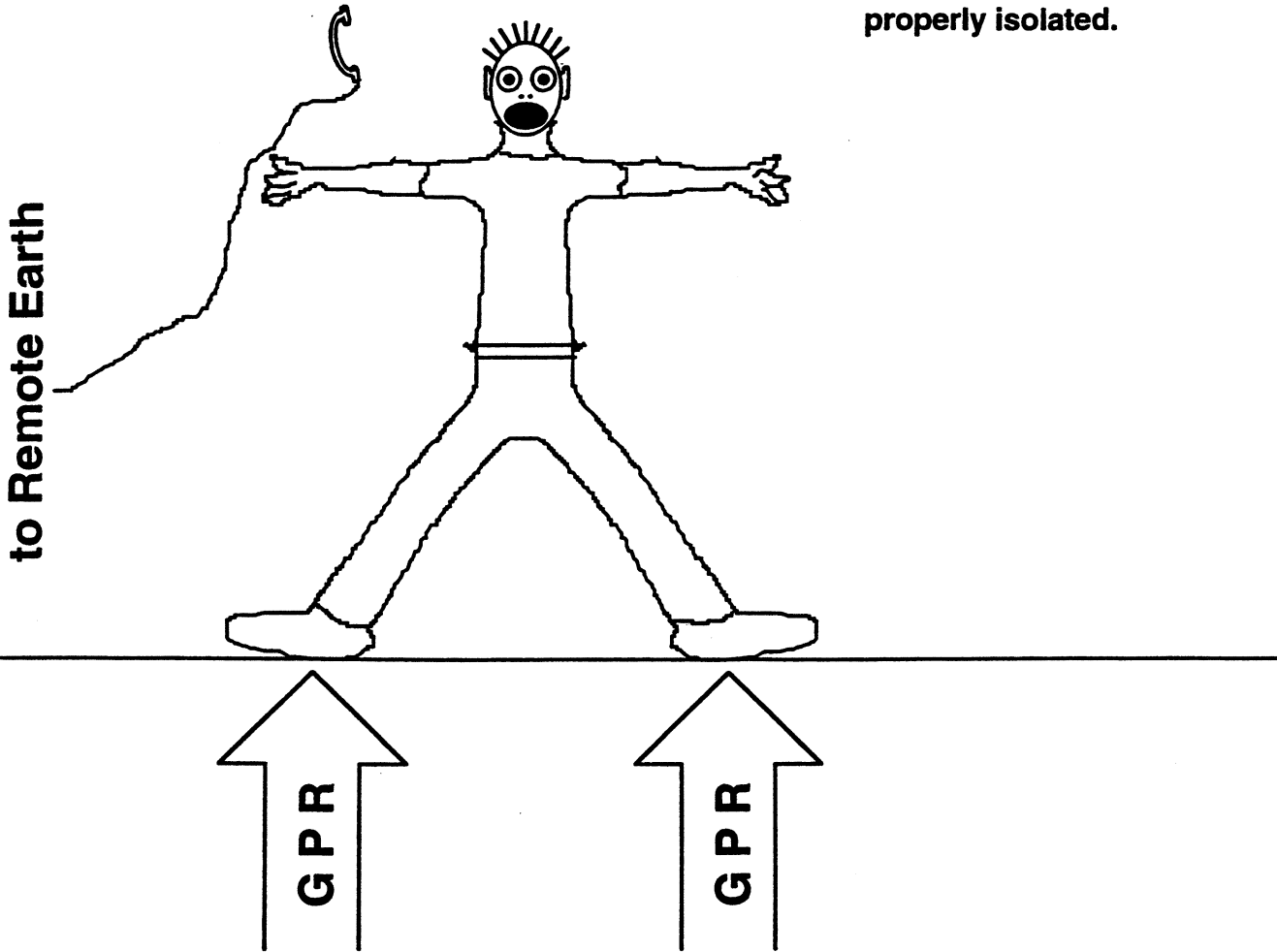

**Network Interface Device  
Located in Zone of  
Influence**

**Current Paths During  
Electrical Fault  
Conditions**

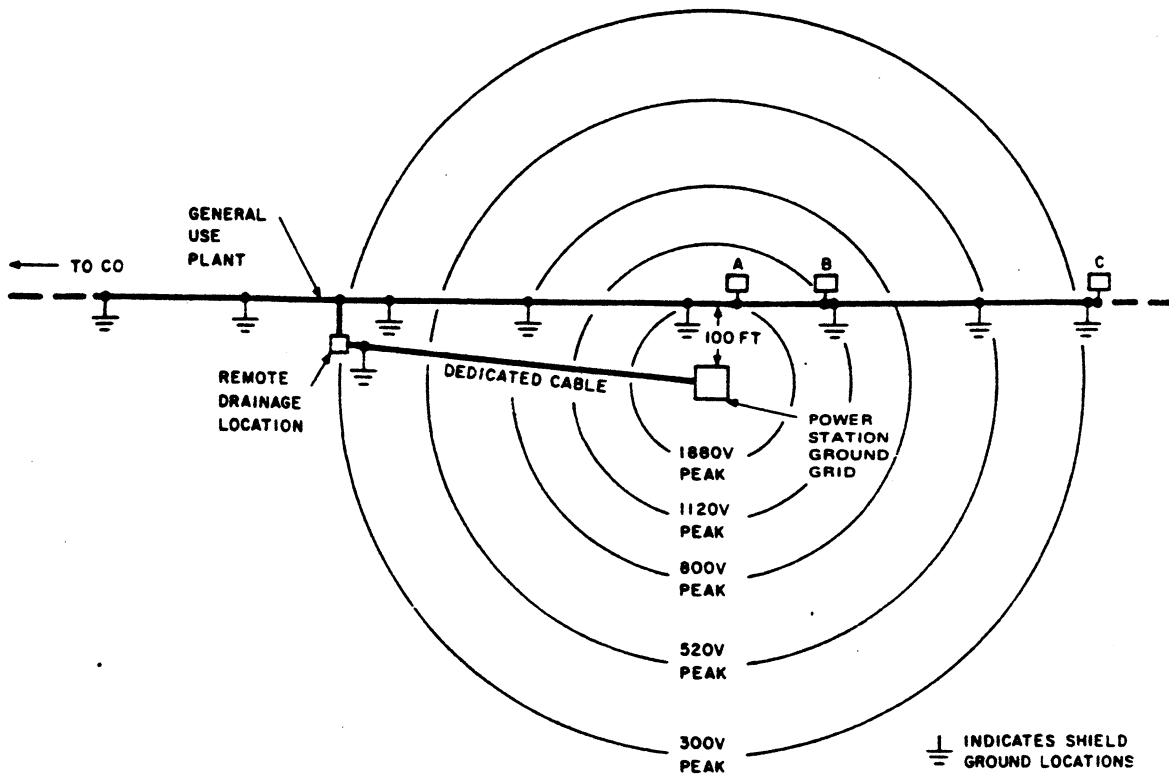
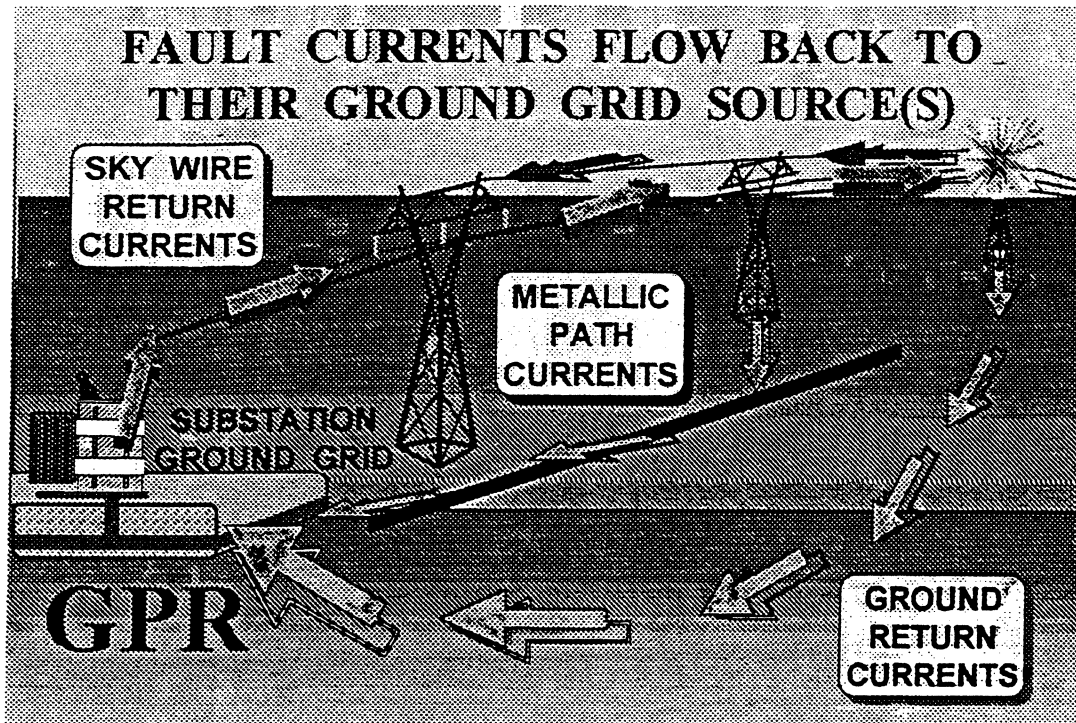

Figure 18 - GPR Voltage Gradient

PROPRIETARY – BELLCORE AND AUTHORIZED CLIENTS ONLY  
See proprietary restrictions on title page.



Fault currents will always flow back to their source(s) of generation through a combination of **SERIES FAULT IMPEDANCES AND PARALLEL CONDUCTING PATHS**. It is essential that the power engineer providing the estimated fault current values understands that the current used in GPR calculations is the current which actually flows through the substation ground grid impedance to remote earth. **IT IS NOT THE TOTAL FAULT CURRENT USED FOR THE DESIGN OF CIRCUIT BREAKER CAPACITY.**

Most values used are usually very high and are based on a substation buss fault condition. If the source is on the grid in question, a buss fault will only circulate current within the grid. This current does not create a GPR voltage condition. In order to arrive at a realistic GPR, factors which limit or reduce fault currents should always be taken into consideration. These include the generator and/or transformer impedance, characteristic line impedances, ground grid impedance, arc resistance (often assumed to be zero), and alternate metallic path current flows.

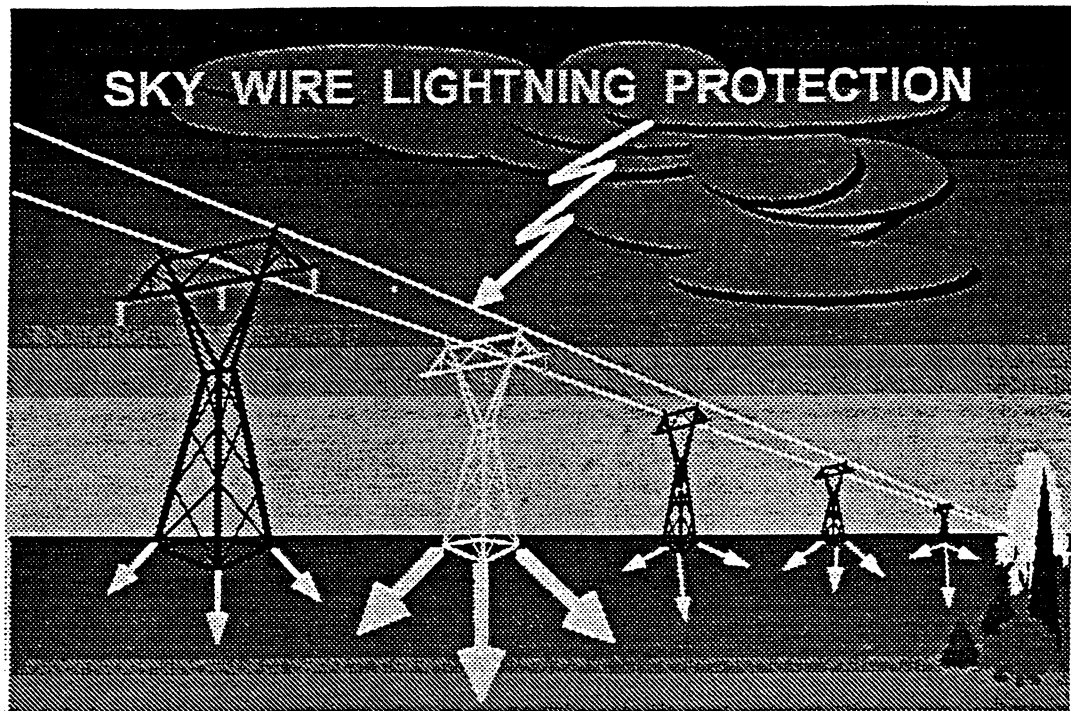

When lightning hits a transmission line, it may terminate on the top of a tower, on the shield sky wire(s), or on the line conductor(s). If it hits a tower, some of the current flows into the sky wires and the rest goes down the tower to ground.

If the impedance of the tower and its footing are low, and the stroke is moderate in terms of current and rise time, the current passes into the ground and nothing happens. If these conditions do not exist, the flow of current through the tower raises the tower voltage above ground level and causes a flashover from the tower, over the line insulators, to one or more of the phase conductors.

When lightning strikes a phase conductor or shield wire, the current of the stroke tends to divide, half going in each direction. Both the current and voltage surges will move along the conductors as **TRAVELING WAVES**. The surge impedance of a power line to lightning is almost purely resistive in nature and ranges in the order of 200-300 ohms.

A properly placed shield wire intercepts around 95% of the lightning strokes that would otherwise hit conductors. But lightning does not always follow a straight vertical path to ground. Occasionally a stroke bypasses a shield during high wind conditions when the phase conductors are blown out beyond their protection zone.

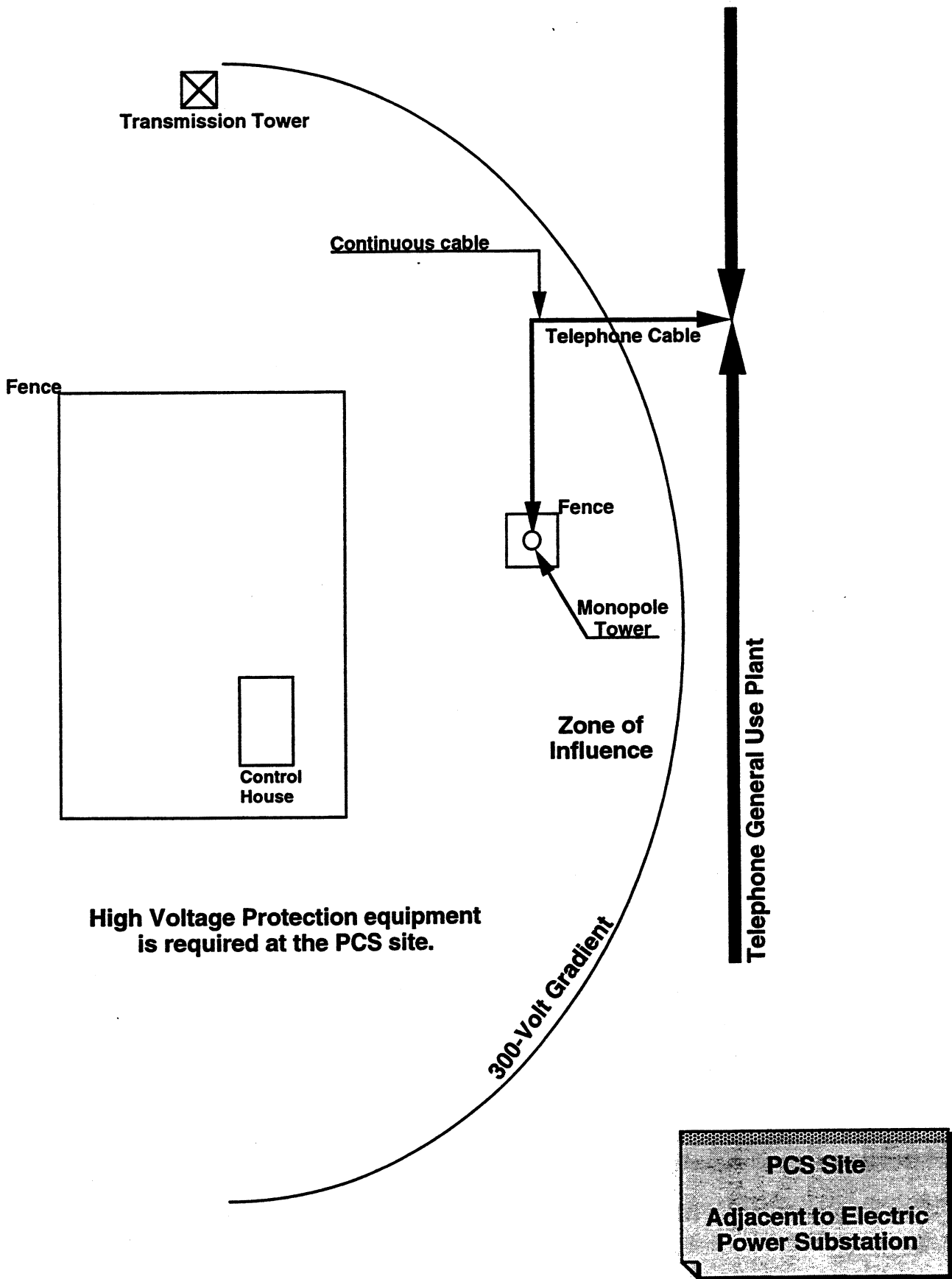



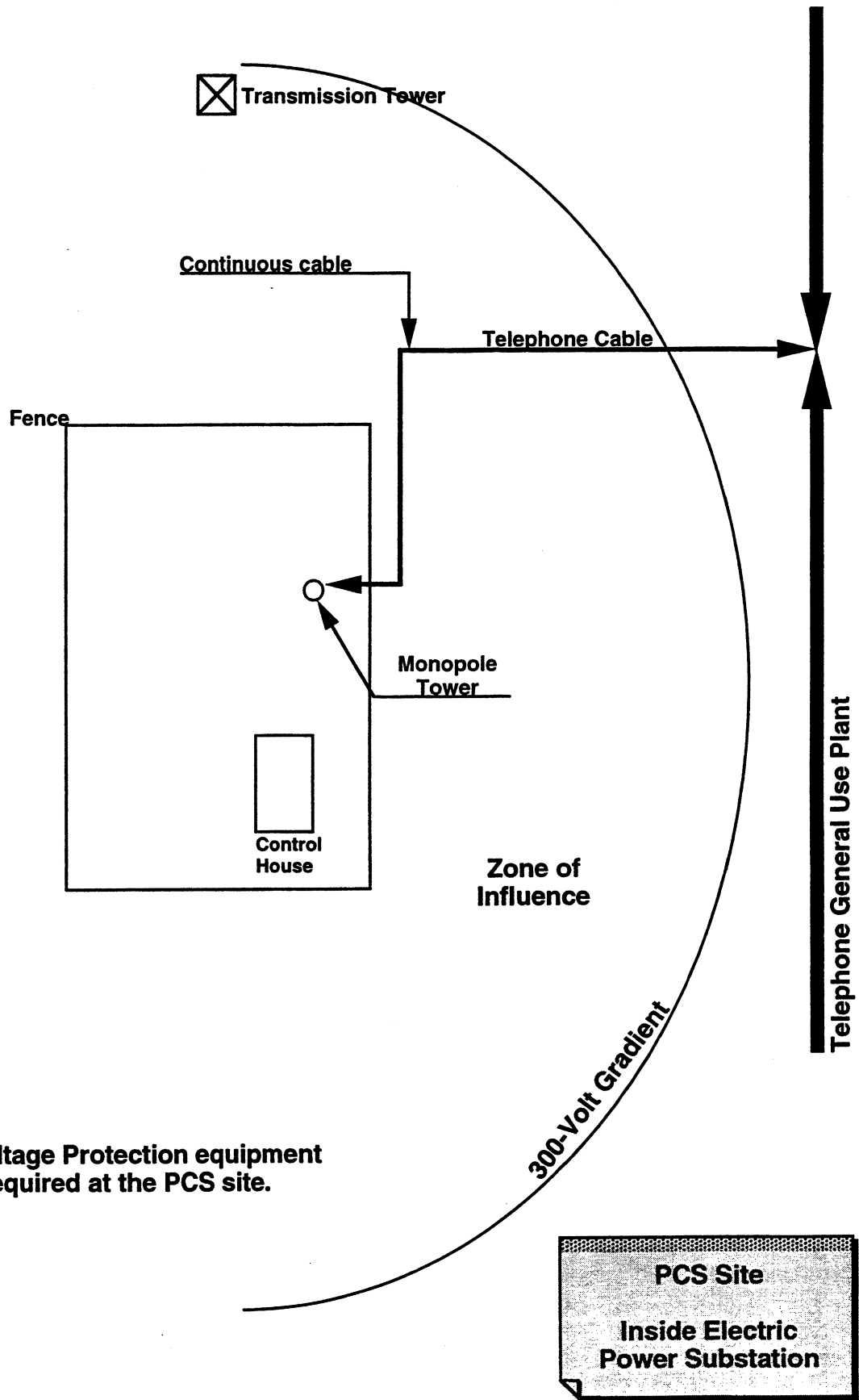

**High Voltage Protection equipment is required at the PCS site.**

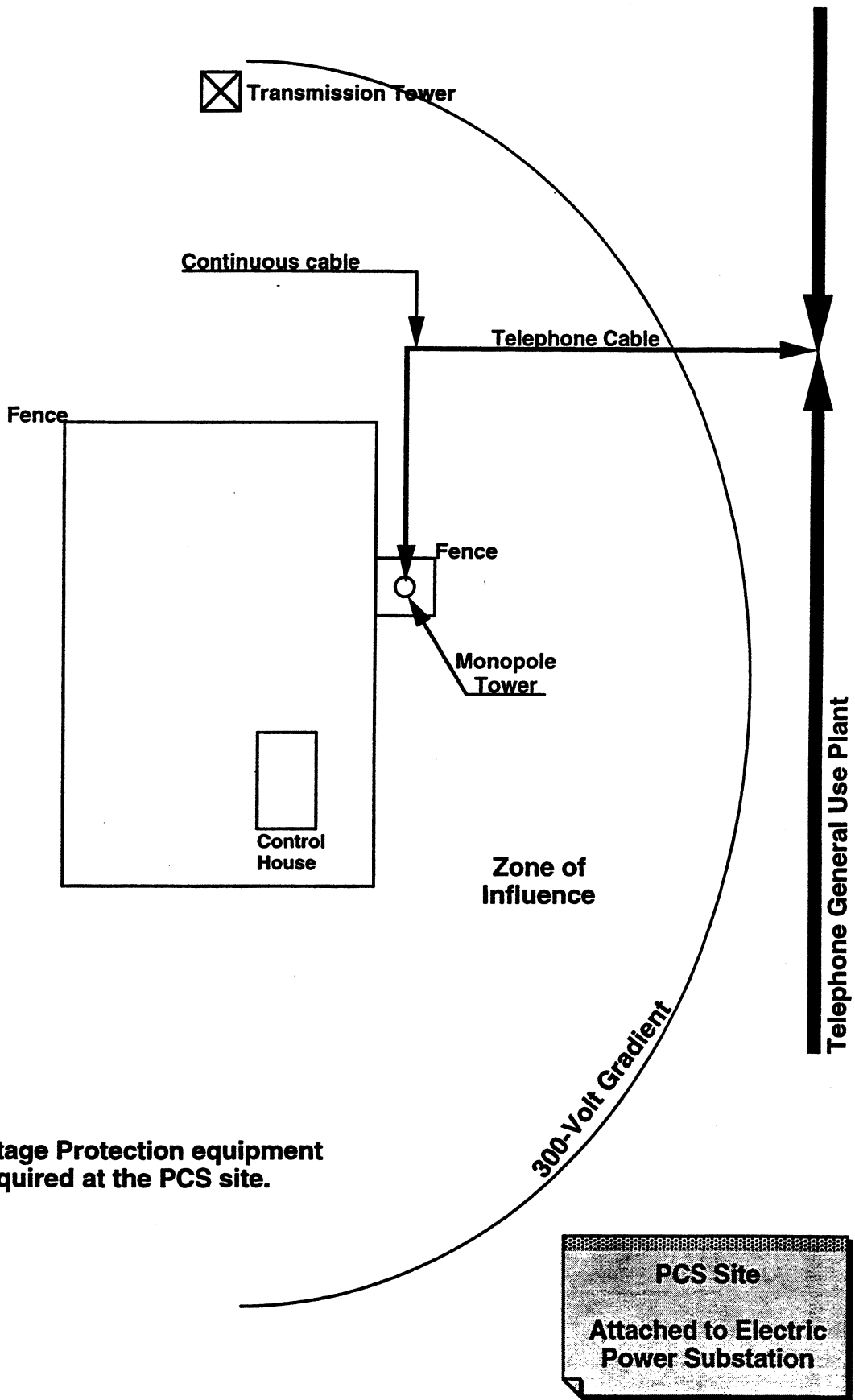

High Voltage Protection equipment is required at the PCS site.

**Wireless Site**

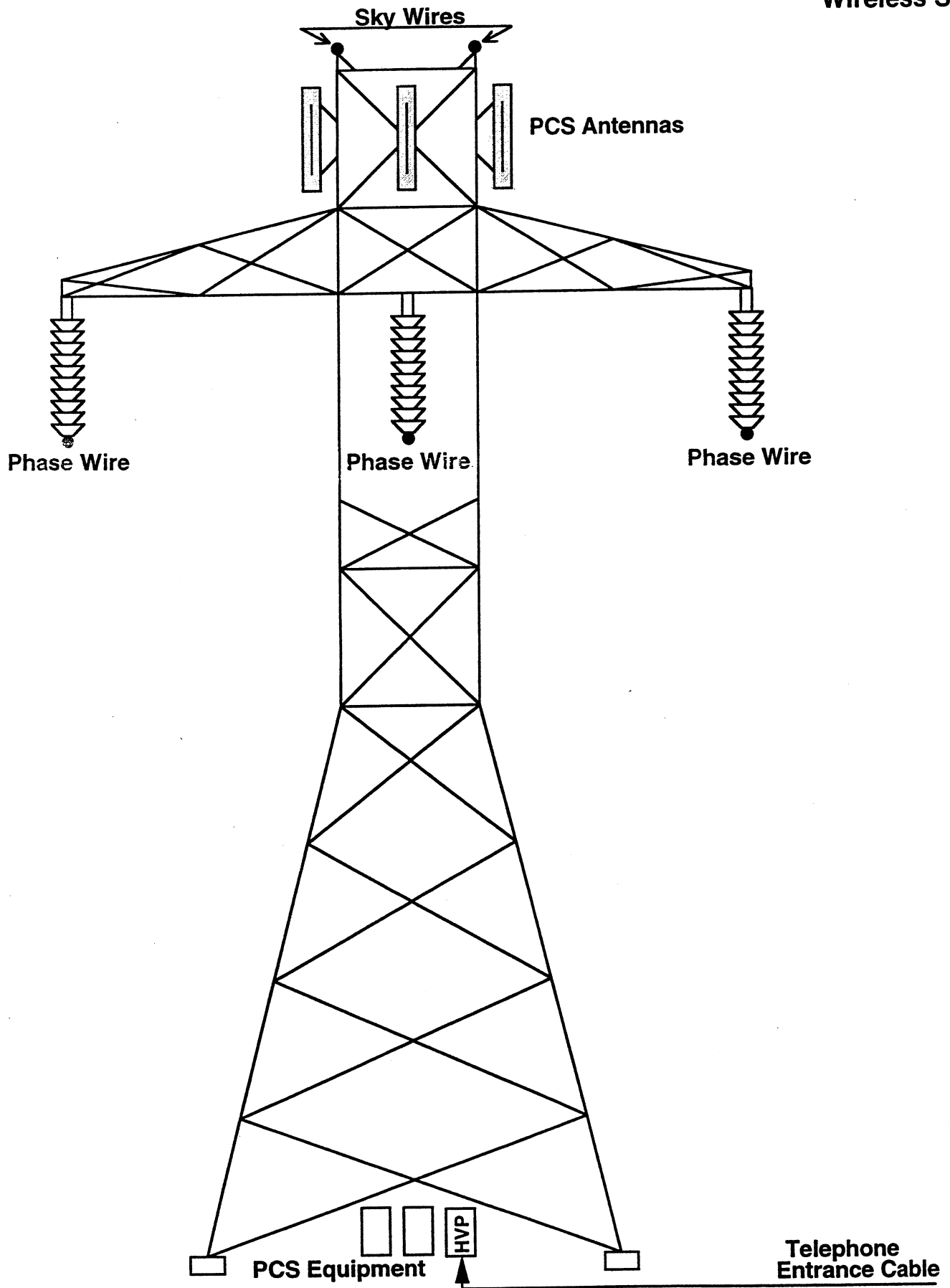

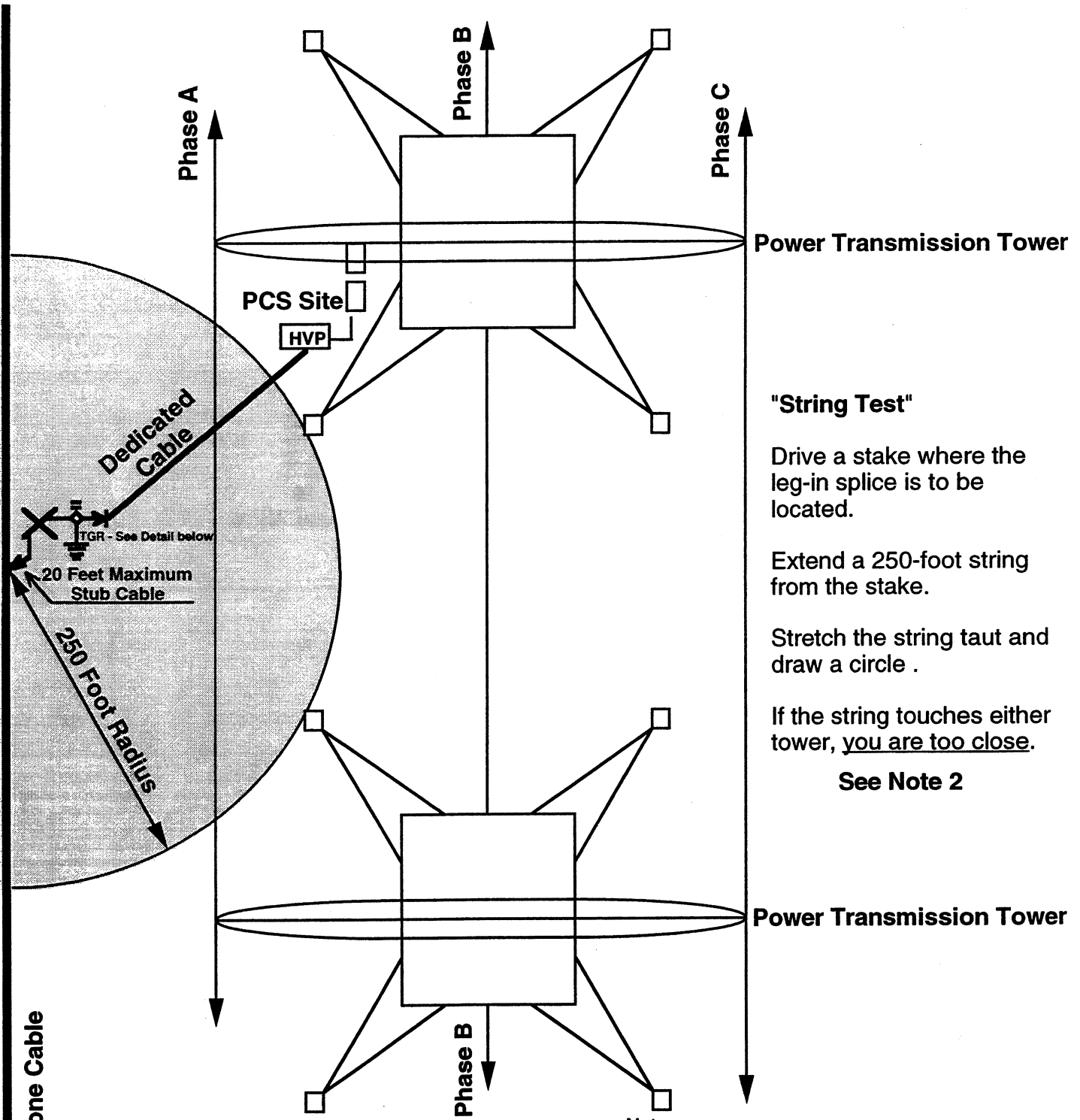

**"String Test"**

Drive a stake where the leg-in splice is to be located.

Extend a 250-foot string from the stake.

Stretch the string taut and draw a circle .

If the string touches either tower, you are too close.

**See Note 2**

Telephone Cable

Notes:

1. Ground field consists of three 8 foot copper-clad rods driven at 10-foot centers and connected together with bare solid #6 wire.
2. Wire connections to rods are exothermally welded (Cadweld or equivalent).
3. All wire sizes #6 or larger.

**Grounding Detail**

1. Power transmission tower sites are classified as high voltage locations **which require special protection equipment.**
2. The dedicated cable **must** extend to a point **at least 250 lineal feet beyond the closest power tower leg.**
3. Close parallel exposures should be avoided whenever possible.

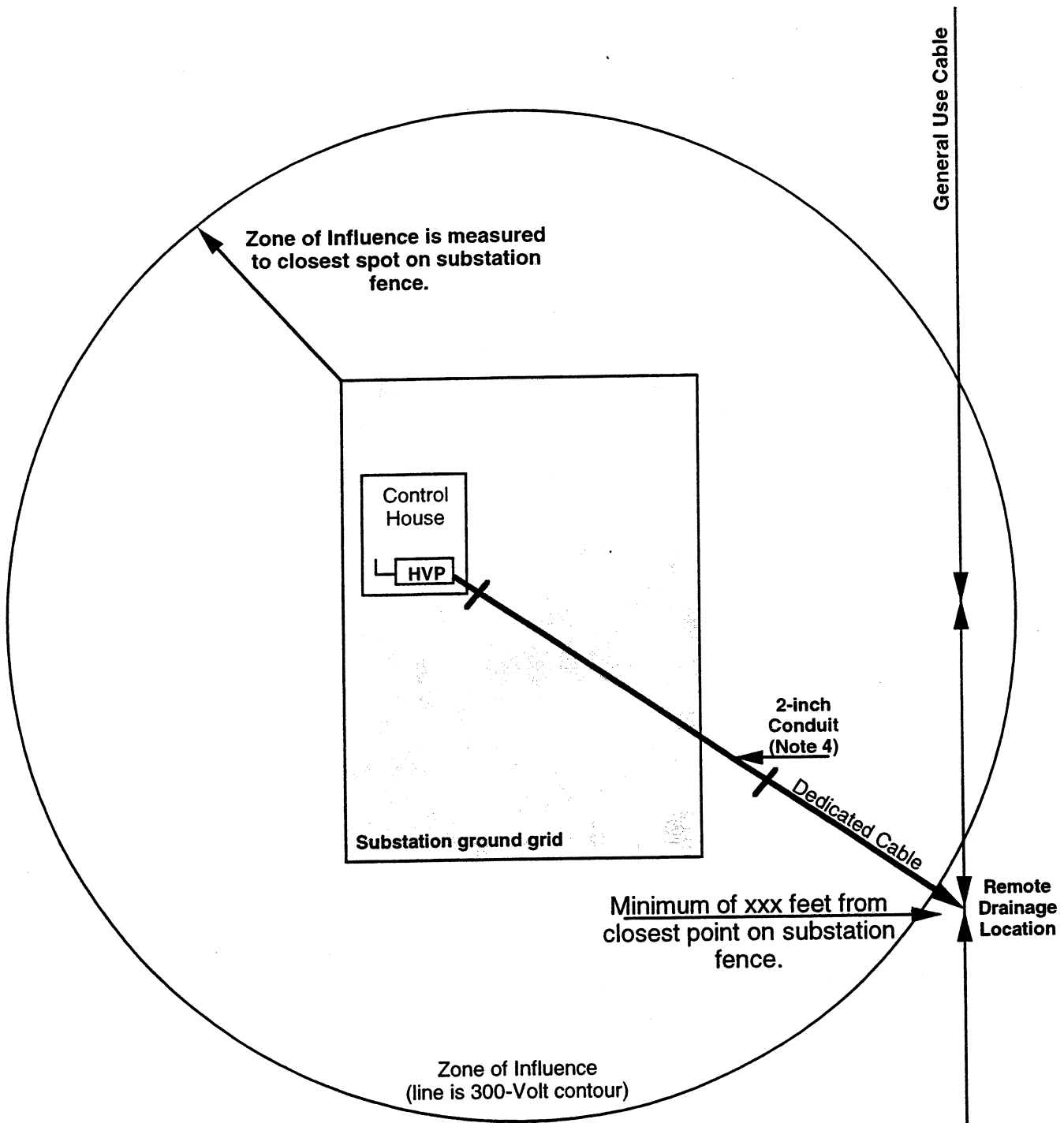

**Guidelines for Cable Placement in Substation:**

1. Dedicated cable extends from High Voltage Interface to 300 V point or beyond before being spliced to general use cable.
2. No grounds are to be placed on dedicated cable until Remote Drainage Location is reached.
3. Maintain cable shield continuity in Zone of Influence.
4. Cable must be in PVC conduit from control house to ten feet beyond edge of substation ground grid.

**Substation Services**  
 where  
**U S WEST**  
 provides the  
**High Voltage Protection**  
 equipment

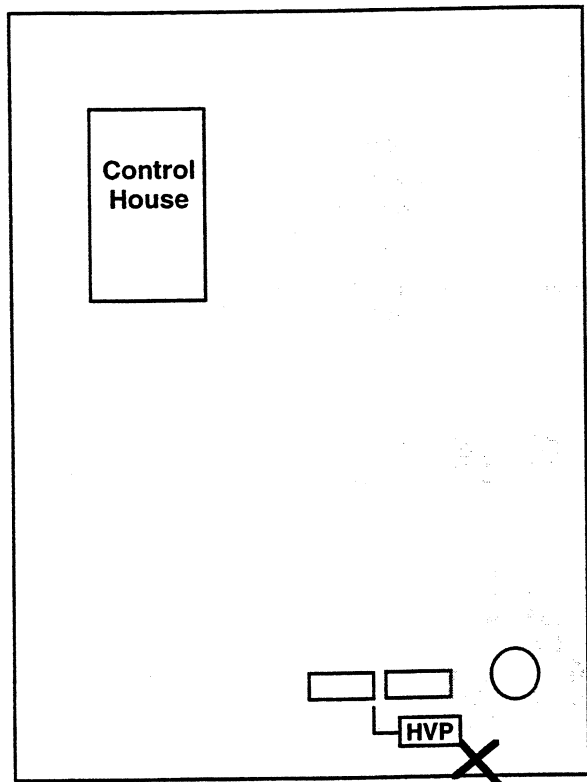

**Remote Drainage Location**

**Remote Protected Terminal**

**Customer Provided HVP Equipment**

**Used in PCS Service where the PCS Equipment is located inside an Electric Power Station**

2-Inch PVC Conduit to at least 10 feet past edge of ground grid

*Zone of Influence*

**Remote Drainage Location**

TGR

20 Feet Maximum

Stub Cable

Minimum of **xxx** feet from closest point on substation ground grid.

General Use Cable Plant

**Grounding Detail**

1. Ground field consists of three 8-foot copper-clad ground rods driven at 10-foot centers and connected together with bare solid #6 wire.

2. Wire connections to rods are exothermally welded (Cadweld or equivalent).
3. All wire sizes #6 or larger.

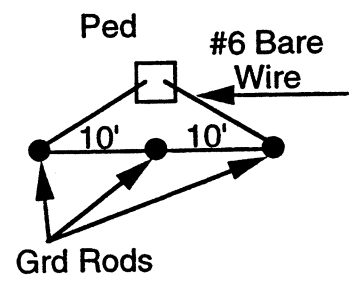

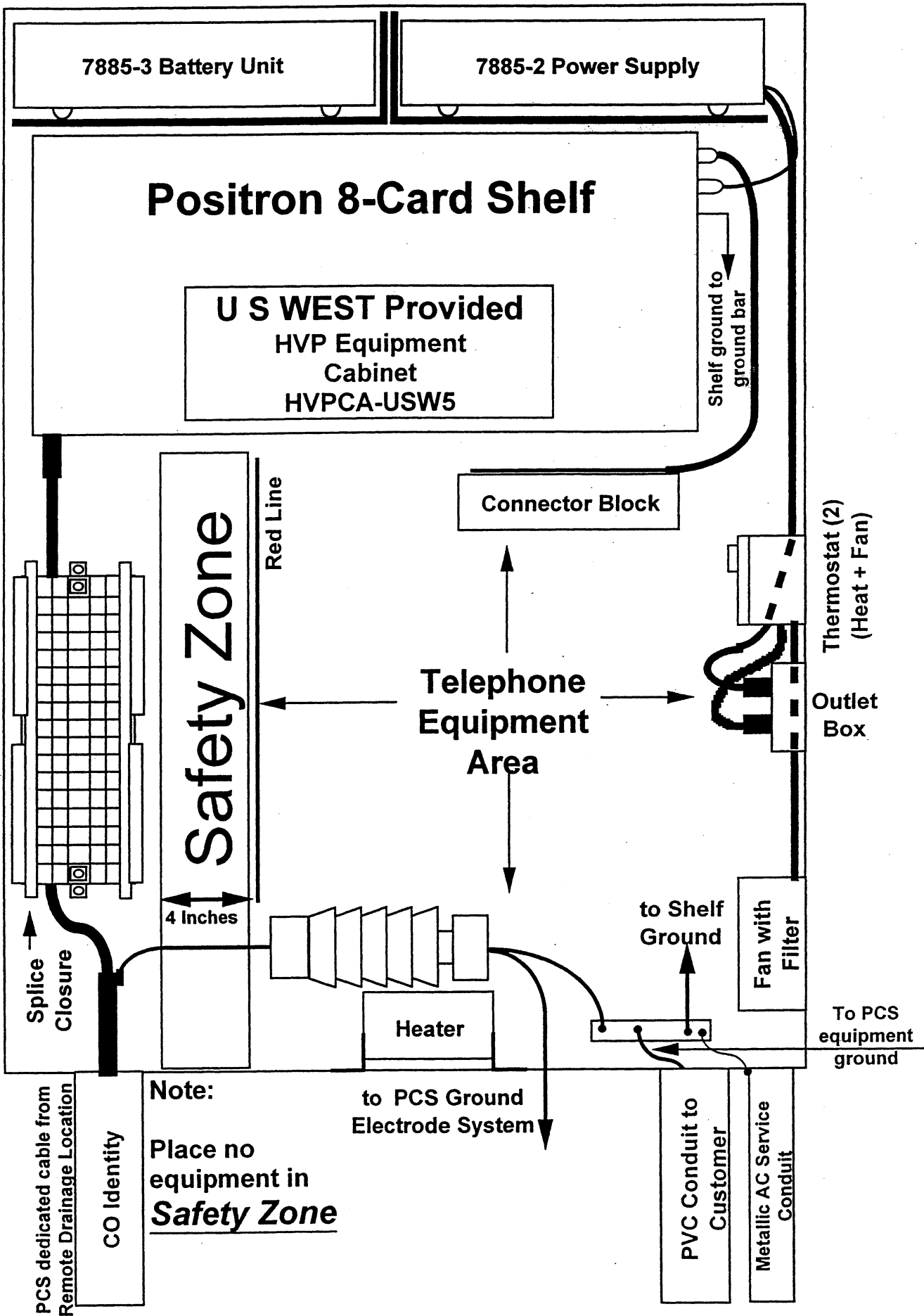

7885-3 Battery Unit

7885-2 Power Supply

# Positron 8-Card Shelf

U S WEST Provided  
HVP Equipment  
Cabinet  
HVPCA-USW5

Shelf ground to  
ground bar

Connector Block

Thermostat (2)  
(Heat + Fan)

Outlet  
Box

Telephone  
Equipment  
Area

Safety Zone

Red Line

4 Inches

Heater

to Shelf  
Ground

Fan with  
Filter

To PCS  
equipment  
ground

PCS dedicated cable from  
Remote Drainage Location

CO Identify

Note:  
Place no  
equipment in  
**Safety Zone**

to PCS Ground  
Electrode System

PVC Conduit to  
Customer

Metallic AC Service  
Conduit

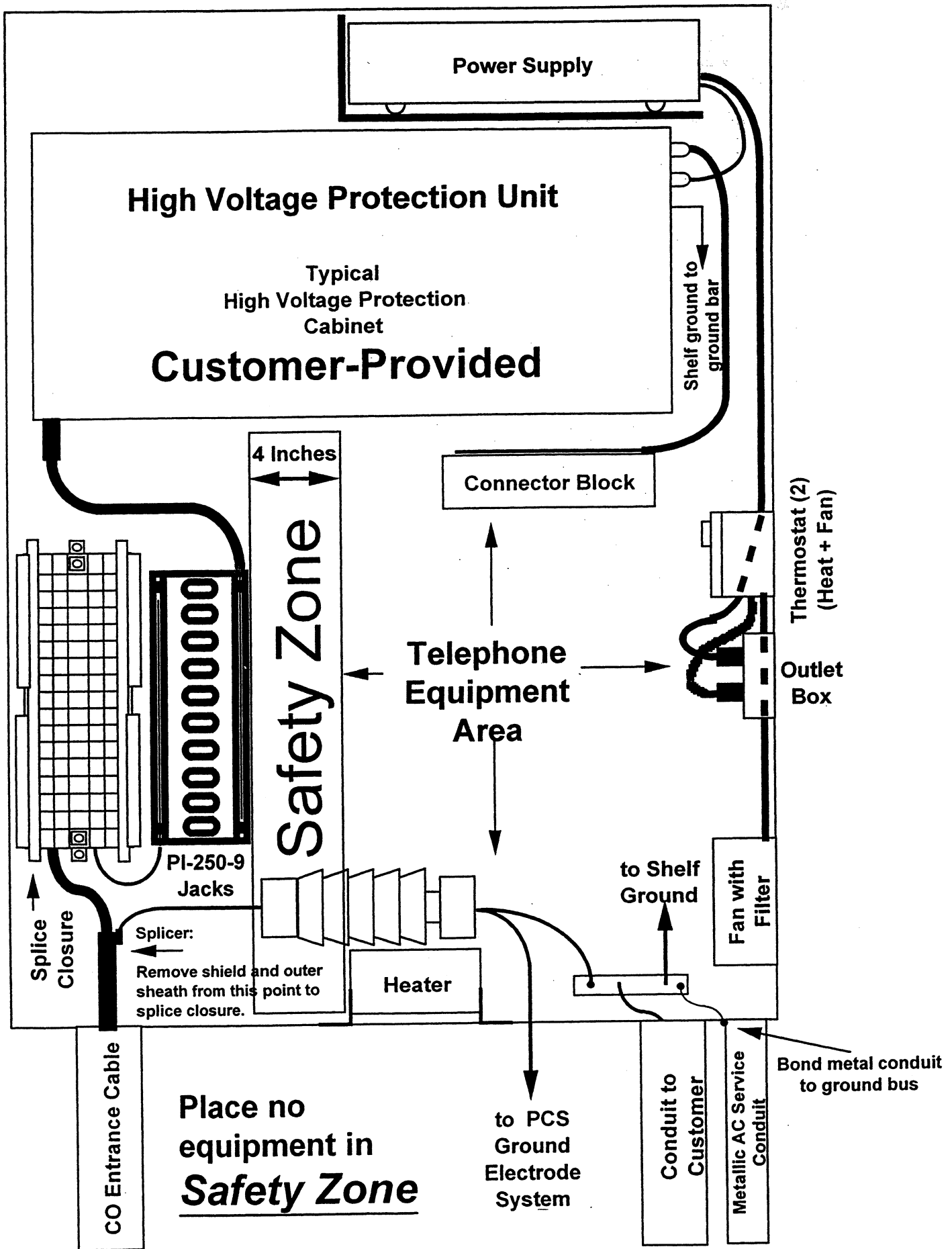



# Lyte Lynx C-Line® Card Shelves

## 12-Slot Card Shelf – P30069

The C-Line 12-Slot Card Shelf holds sufficient circuit cards to fully utilize a 25 pair cable, while using only 28 inches of horizontal wall space, providing nearly twice the density of competing modular systems.

The efficiency of this design starts with card slots spaced at 1.5 inch intervals. The result is 24 pair service in 12 slots (six Teleline Isolator\* cards can be accommodated). Convenient terminations for entrance cables make installation a breeze, and the shoebox-like cover is a snug fit that is easily removed.

Half height power supply slots in the upper left hand corner of the shelf allow for various combinations of substation power to energize the electronics on the substation side of active fiber optic (voice) PC cards.

The station side of this card shelf may be powered by 24VDC, 48VDC, 130VDC or 120VAC power. The shelf will accept any two of these power sources at one time (one as primary power and another as secondary active backup power) to provide continuous operation in the event of a power supply card failure or power outage.

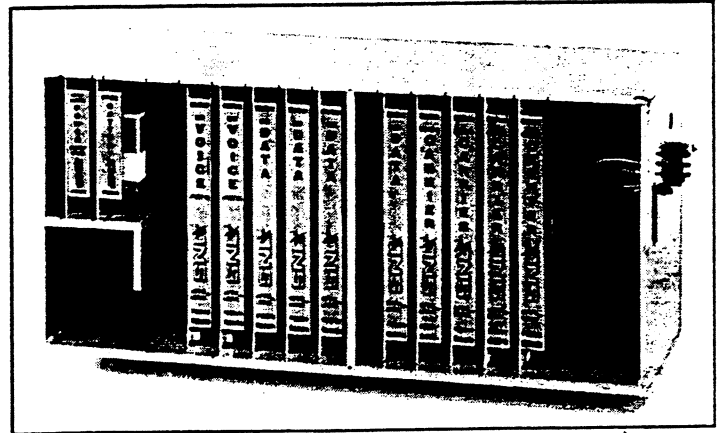

**P30069 C-Line 12-Slot Card Shelf (Cover Removed)**  
CLEI Code NPMICBBRA

## 3-Slot Card Shelf – P30075

The C-Line 3-Slot Card Shelf presents an extremely small footprint in card shelf design, making it ideal for installations where space is at a premium and six or less circuits are required. Wall space as little as 96 square inches is required, providing nearly twice the density of competing modular systems.

The C-Line 3-slot provides an isolated interface for voice (POTS), analog data and digital circuits, depending on the isolation cards inserted into the shelf. The card slots are spaced at 1.5 inch intervals, enabling the shelf to accept three SNC C-Line cards, or one Teleline Isolator\* card and one C-Line card. Each slot supports two telephone pairs (see our 4-wire voice card on page 6 for information on doubling the capacity of a single slot). Any combination of two or four-wire service can be used. The station side backplane distributes 24 volt power to each slot. Either one of the SNC full size internal power supply cards (130VDC P30078 or 48VDC P30079) may be used in any of the three card shelf slots.

A variety of external powering configurations is also offered. See pages 7-10 of this catalog or refer to the installation instructions that ship with individual cards for specific powering options.

*See the SNC Test Card on page 6 for easy access to card shelf backplane terminations!*

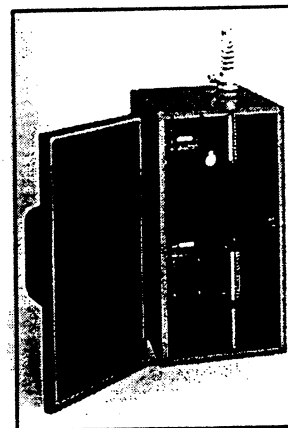

**P30075 C-Line 3-Slot Card Shelf**  
CLEI Code NPMICDBBRA

	HEIGHT	WIDTH	DEPTH
<b>P30069</b> 12-SLOT SHELF	13.125" (33.5 cm)	28" (71 cm)	9.75" (25 cm)
<b>P30075</b> 3-SLOT SHELF	13.25" (33.5 cm)	7.25" (18 cm)	8.75" (22.6 cm)

\*Teleline Isolator is a trademark of Positron Industries, Inc.

# C-Line<sup>®</sup> Turnkey Protection Packages

These custom designed turnkey solutions offer a variety of weatherproof fiberglass enclosures for housing your choice of protection equipment and accessories. Options to select from include power supplies, termination blocks, lightning arresters, splice/termination enclosures, Plexiglas safety shield, heater, fan, thermostat and 3 or 12-slot C-Line card shelves.

The configurations shown here are standard, off-the-shelf packages. If you require a different configuration let us know. SNC will work with you to design a package to exactly fit your needs. Call for additional information and pricing.

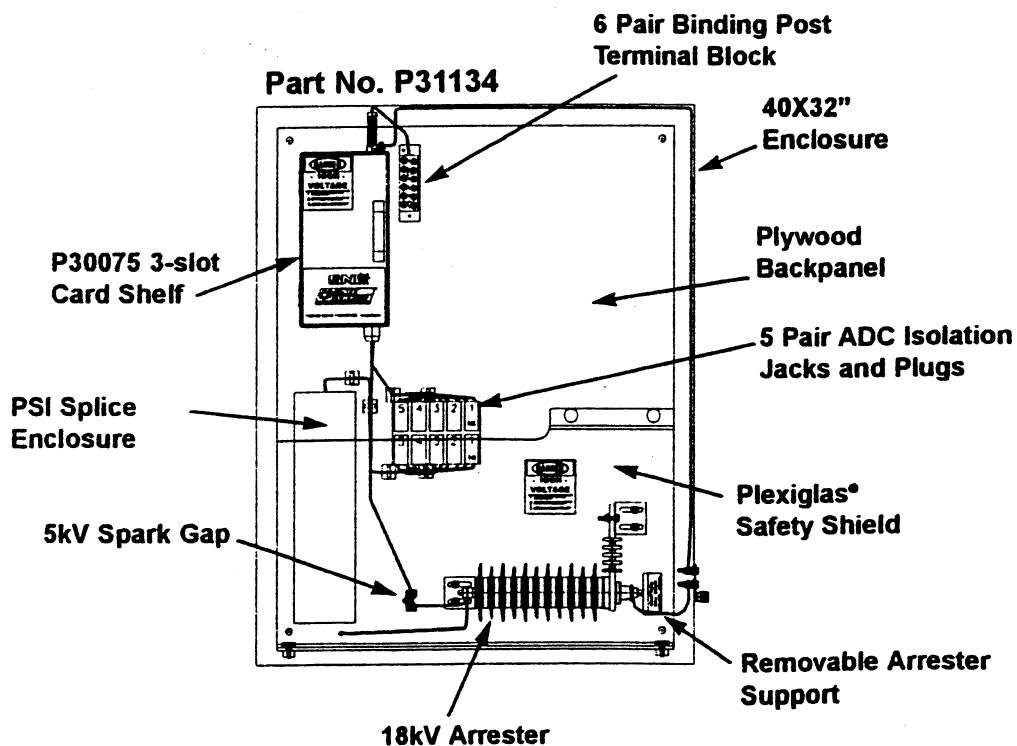
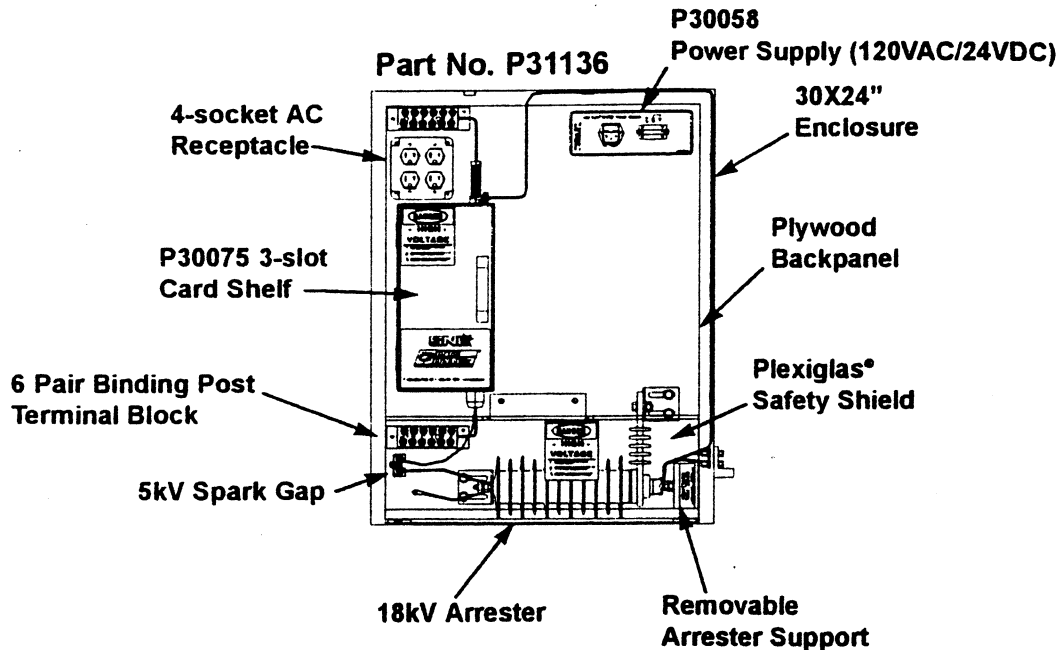

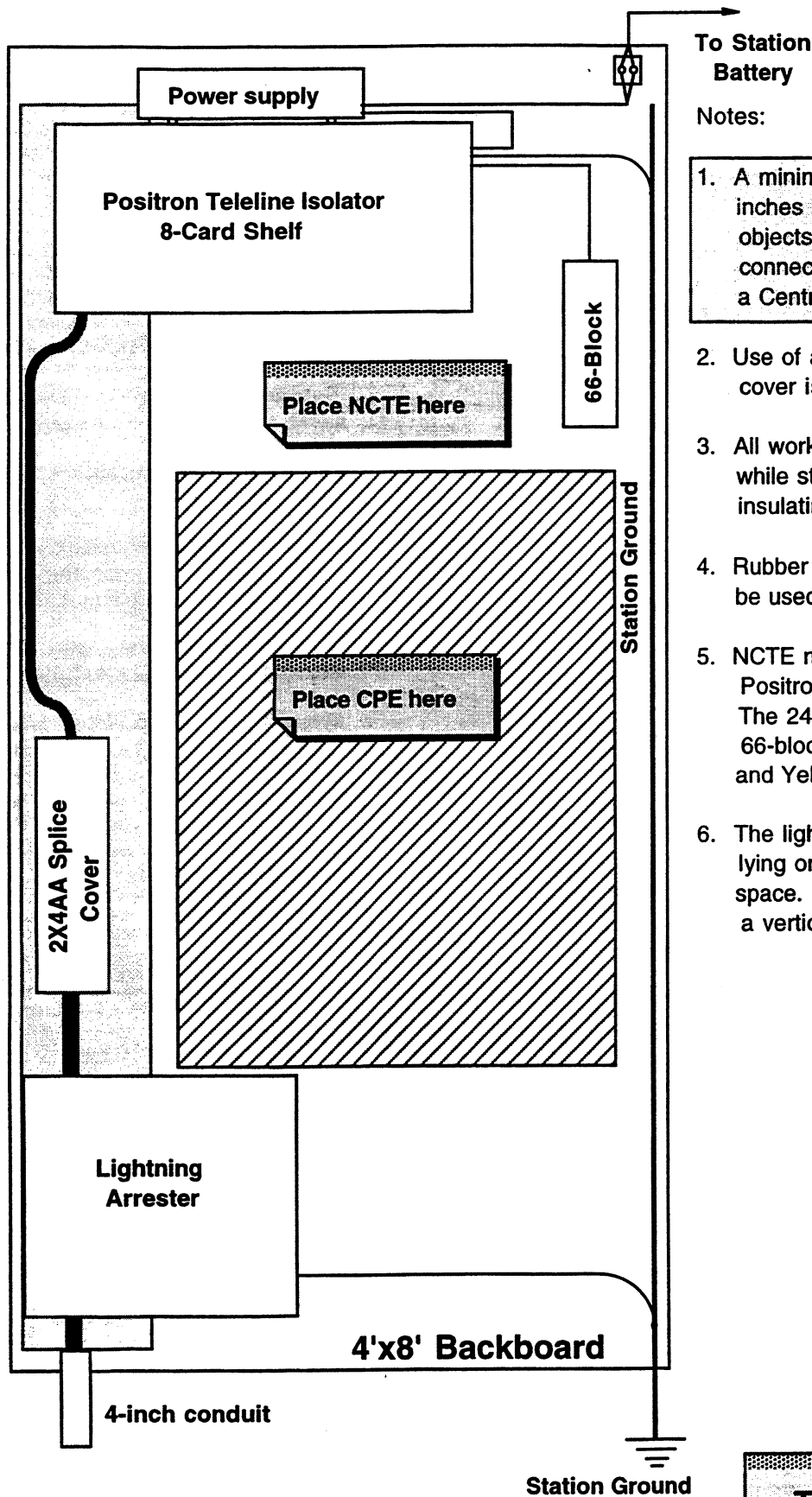

Notes:

1. A minimum separation of four inches is required between objects having a station connection and objects having a Central Office connection.
2. Use of a non-metallic splice cover is required for safety.
3. All work should be performed while standing on a rubber insulating blanket.
4. Rubber insulating gloves should be used whenever possible.
5. NCTE may be powered from the Positron power supply output. The 24 volts appears on the 66-block on the Yellow/Slate and Yellow/Green wires.
6. The lightning arrester is shown lying on its side to conserve space. It may also be used in a vertical orientation.

**Typical Terminal  
Backboard Design**

**US WEST Provided HVP**

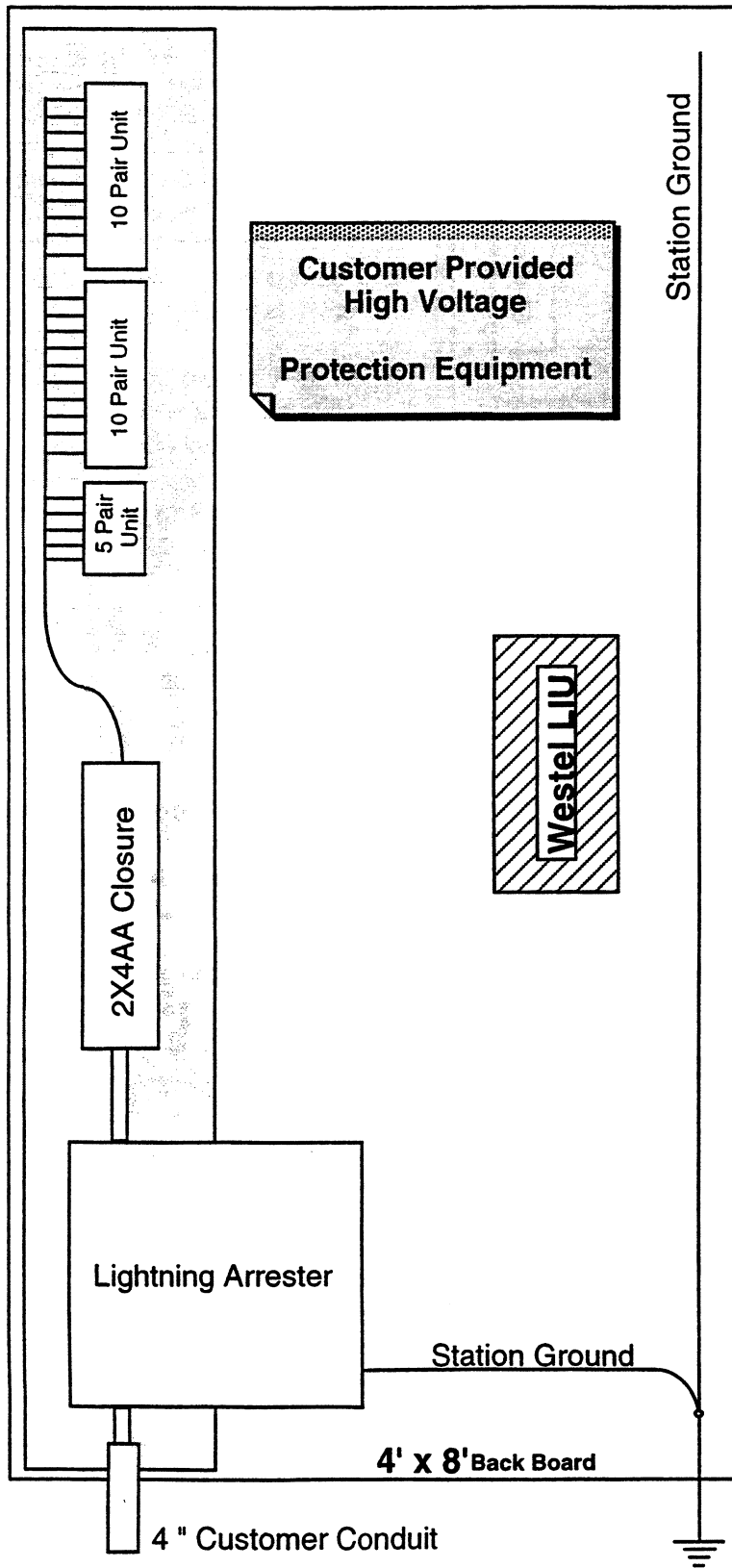

**Notes:**

1. A minimum separation of **four** inches is required between objects having a station connection and objects having a Central Office connection.
2. Remove cable sheath and wrapper. Cover sheath end with splice cover.
3. Fan pairs to Isolation Jack Panels and terminate on jacks.
4. Wrap cable pairs with polyethylene from sheath end to final terminated pair. Use tape to keep wrap from unraveling.
5. Fold back unused pairs, wrap with polyethylene, and tape for future use.
6. When placing new facilities, work operations in the high voltage location should be completed prior to splicing the dedicated cable into the general use plant. This precaution will help limit the safety hazard presented by the high voltage environment.

**Typical Terminal  
Backboard Design**

**Customer Provided  
HVP**

**MUX Application**

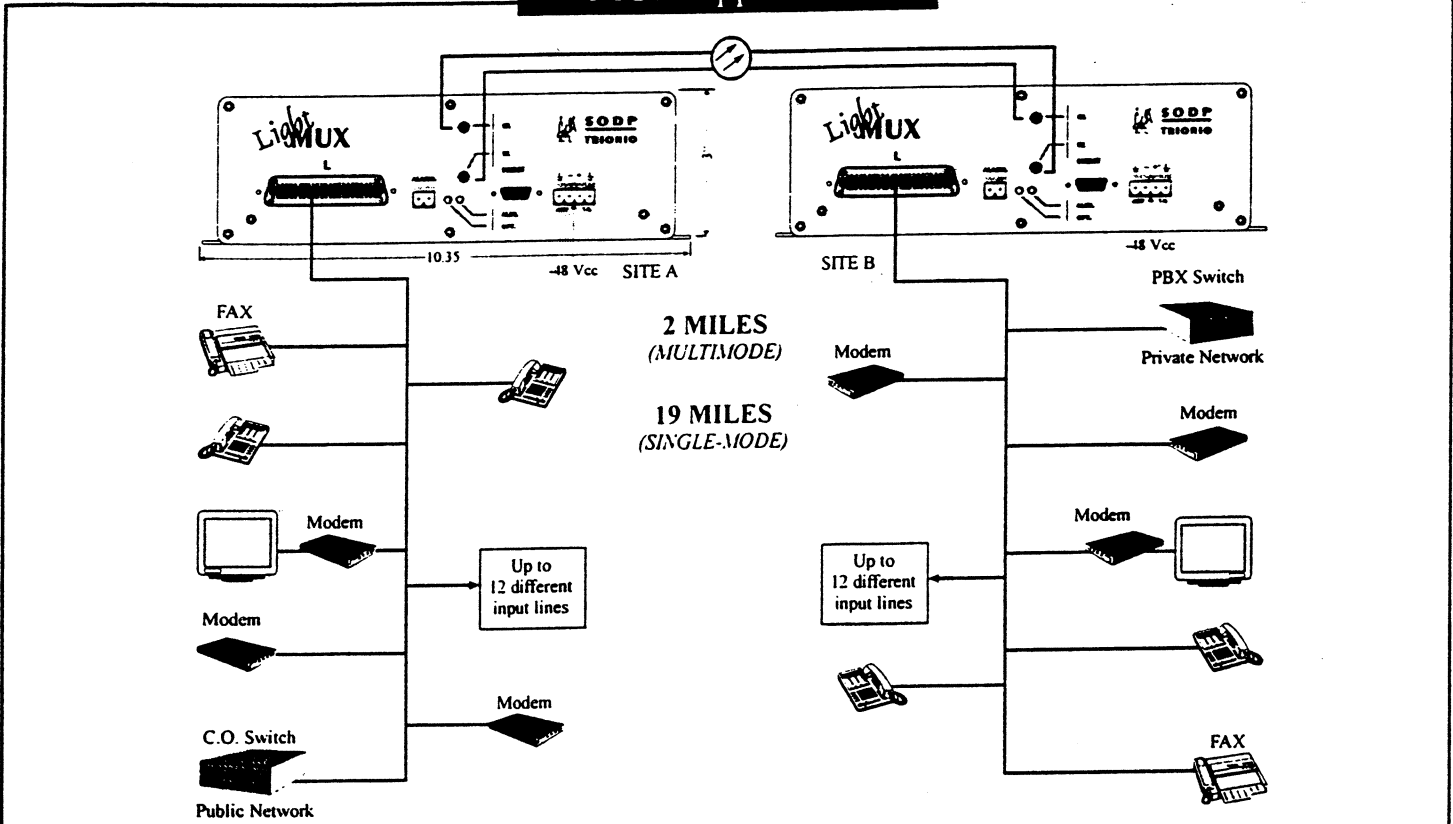

Carries via a singlemode or a multimode fiber optic cable up to 12 various combinations of voice and data signals as well as ringing and signaling signals (impulse or DTMF).

- Line extension between 2 sites
- New line installation
- Point-to-point configuration
- Small installation between two sites
- Voice and data lines applications
- 2 and 4 wire SCADA lines interface
- Access of PBX trunk line
- Access of CO switch

**Fiber Optic Link Isolation Application**

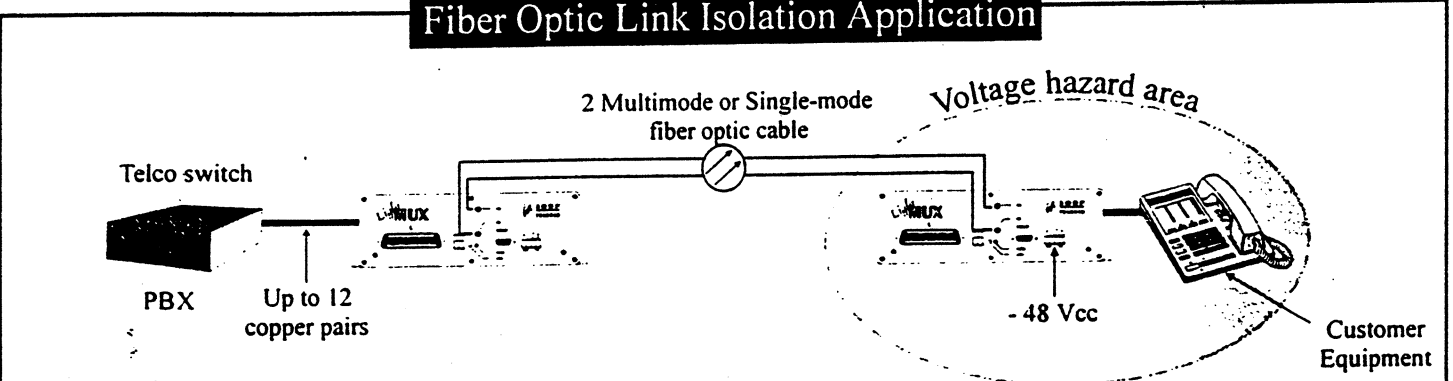

The Light MUX allows multiple protection such as:

- Increase in the grounding potential following a network fault (in electrical transforming stations): GPR problem
- Electrical isolation
- Isolation of 2 and 4 wire SCADA lines
- Isolation of PBX trunk link
- Isolation of CO
- Malfunction or failure by poor grounding
- Protection of copper connection between substations
- Removal of copper cable passing through a voltage hazard area
- Removal of copper telephone lines in lightning proven areas
- A 2 wire switched line
- A point to point 2/4 wire link

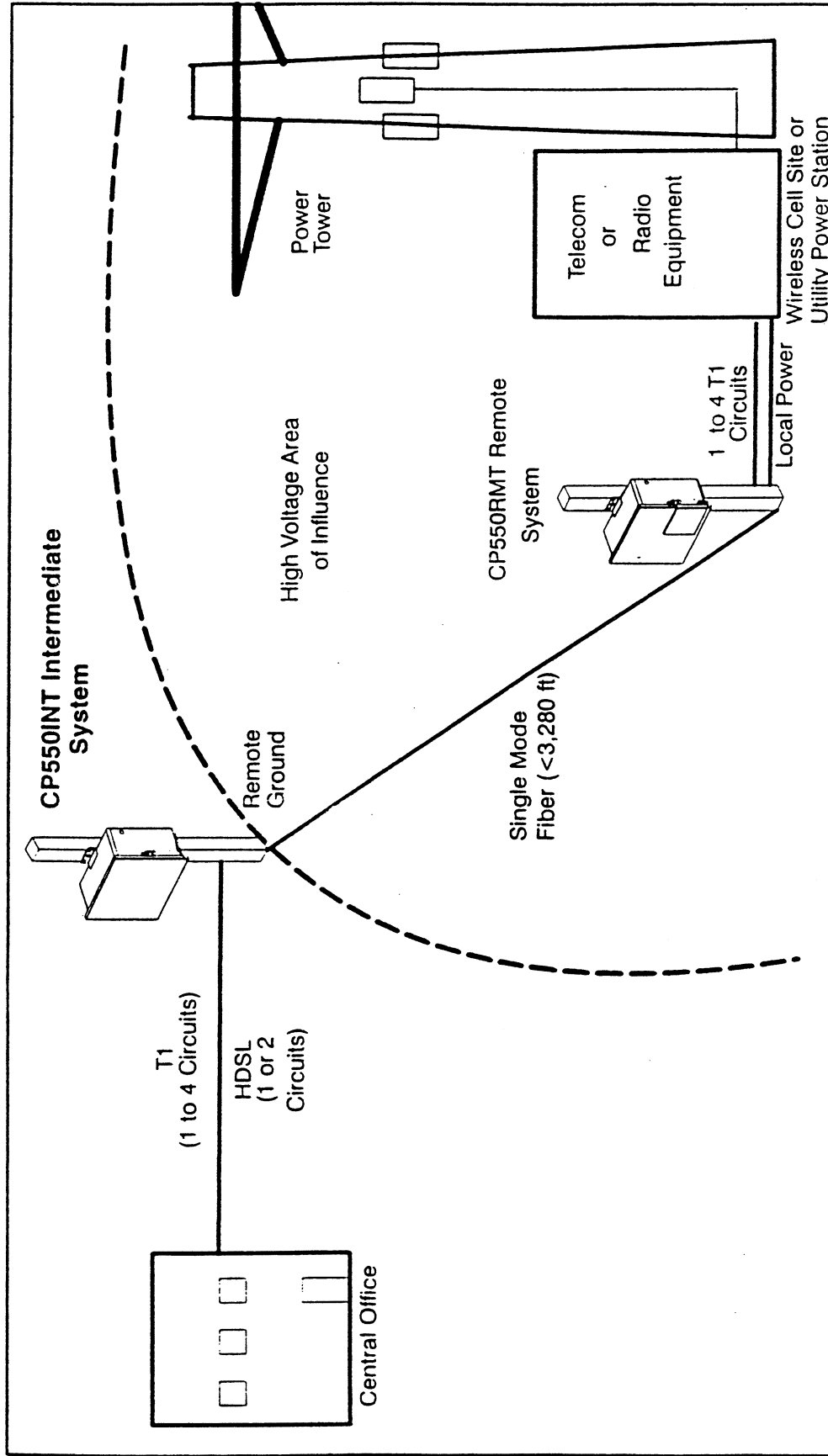
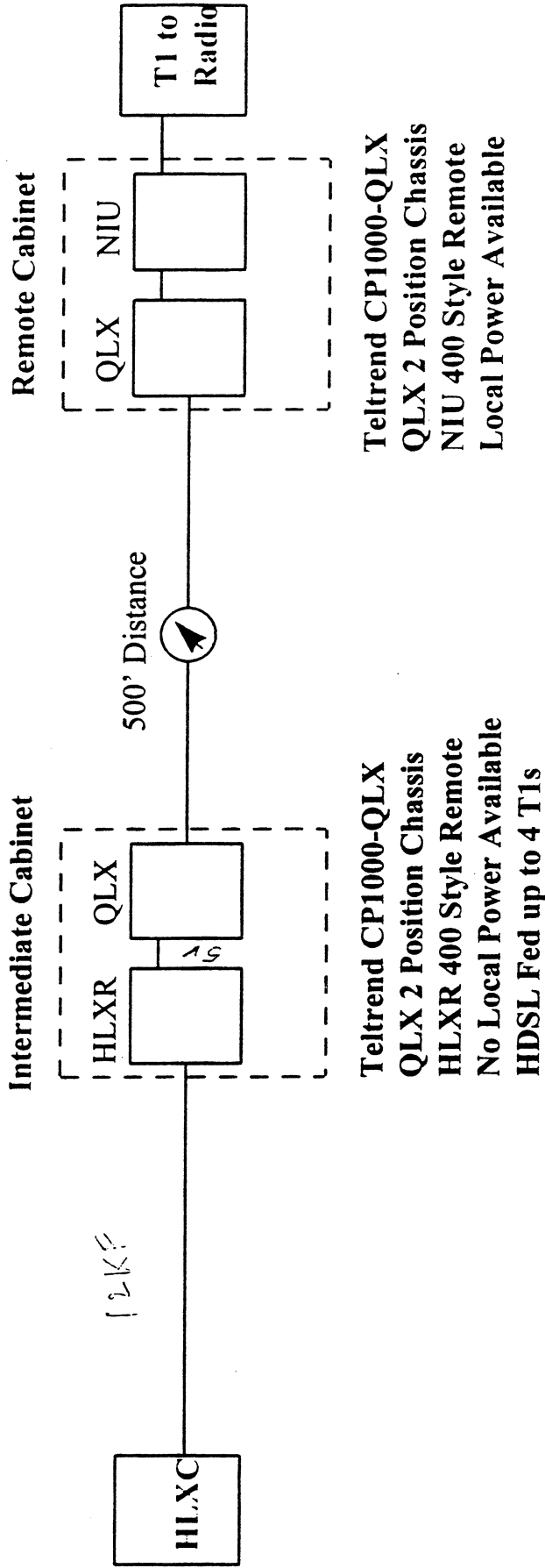

Figure 2. Typical CP550INT High Voltage Application

# ADC Solution for Cell Sites Located on Power Towers

## General Architecture - HDSL Powered QLX



Teltrend CP1000-QLX  
 QLX 2 Position Chassis  
 NIU 400 Style Remote  
 Local Power Available

Teltrend CP1000-QLX  
 QLX 2 Position Chassis  
 HLXR 400 Style Remote  
 No Local Power Available  
 HDSL Fed up to 4 T1s

Trans port systems Group



# Isolation Schematic

*The RLH Fiber Optic Link provides absolute isolation for telephone cable pairs into or through an area where dangerous Ground Potential Rise could occur.*

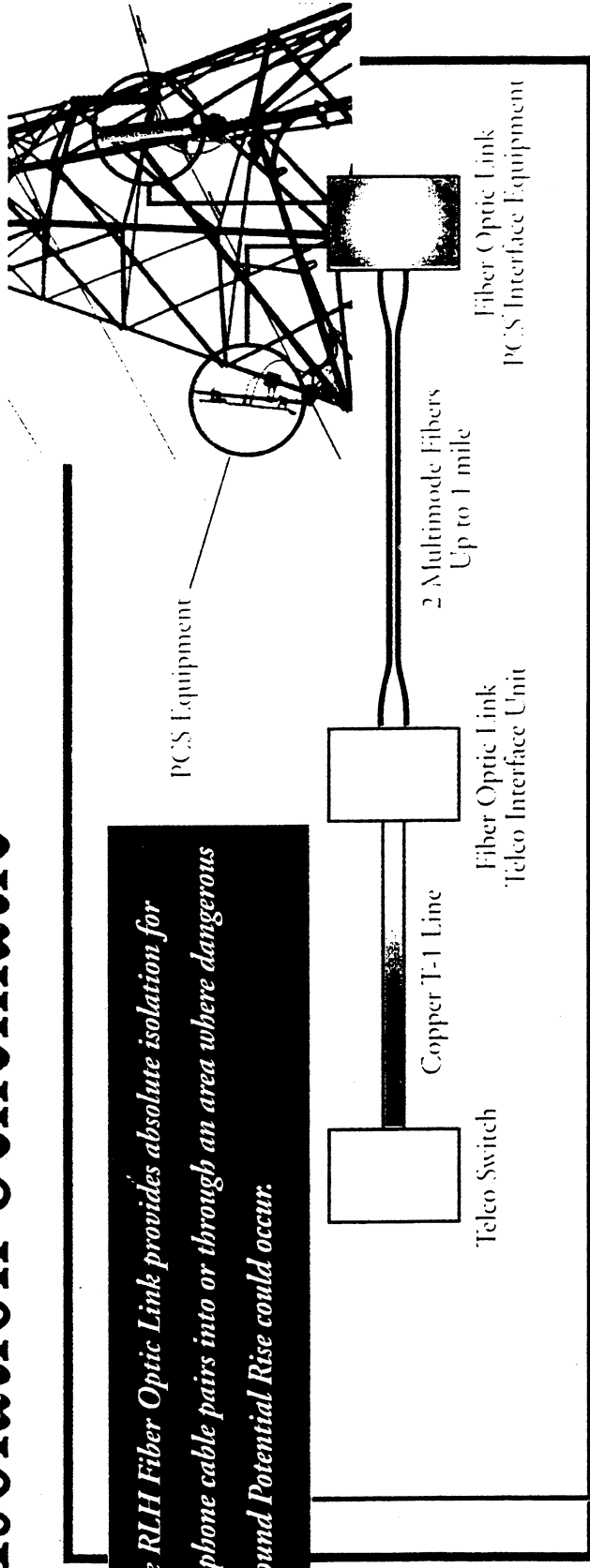

- HDLSL Compatible
- Up to five T-1 lines per 5-card shelf
- 2W POTS, Data, 56 Kbit, DDS, 4W E&M, available
- Absolute safety for Telcos and PCS carriers



**Grounding Detail**

1. Ground field consists of three 8-foot copper-clad ground rods driven at 10-foot centers and connected together with bare solid #6 wire.
2. Wire connections to rods are exothermally welded (Cadweld or equivalent).
3. All wire sizes #6 or larger.

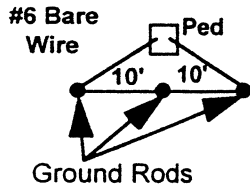

**Notes:**

CP-550 Cell Pack must be located at least 500 feet from the closest point on the power transmission line.

RJ-48 demark is in the CP-550 Cell Pack.

Line power of CP-550 is permitted for High Voltage Protection situations. Do Not use commercial power or ground to power neutral or MGN, locate at least 10 feet from power poles or pedestals.

If the circuit terminates near a power substation, the substation Zone of Influence must be calculated prior to the design being issued.

**Note:**

Do Not place any Metallic conductors between PCS site and this location, PVC conduit only. Place locate targets every 50 feet.

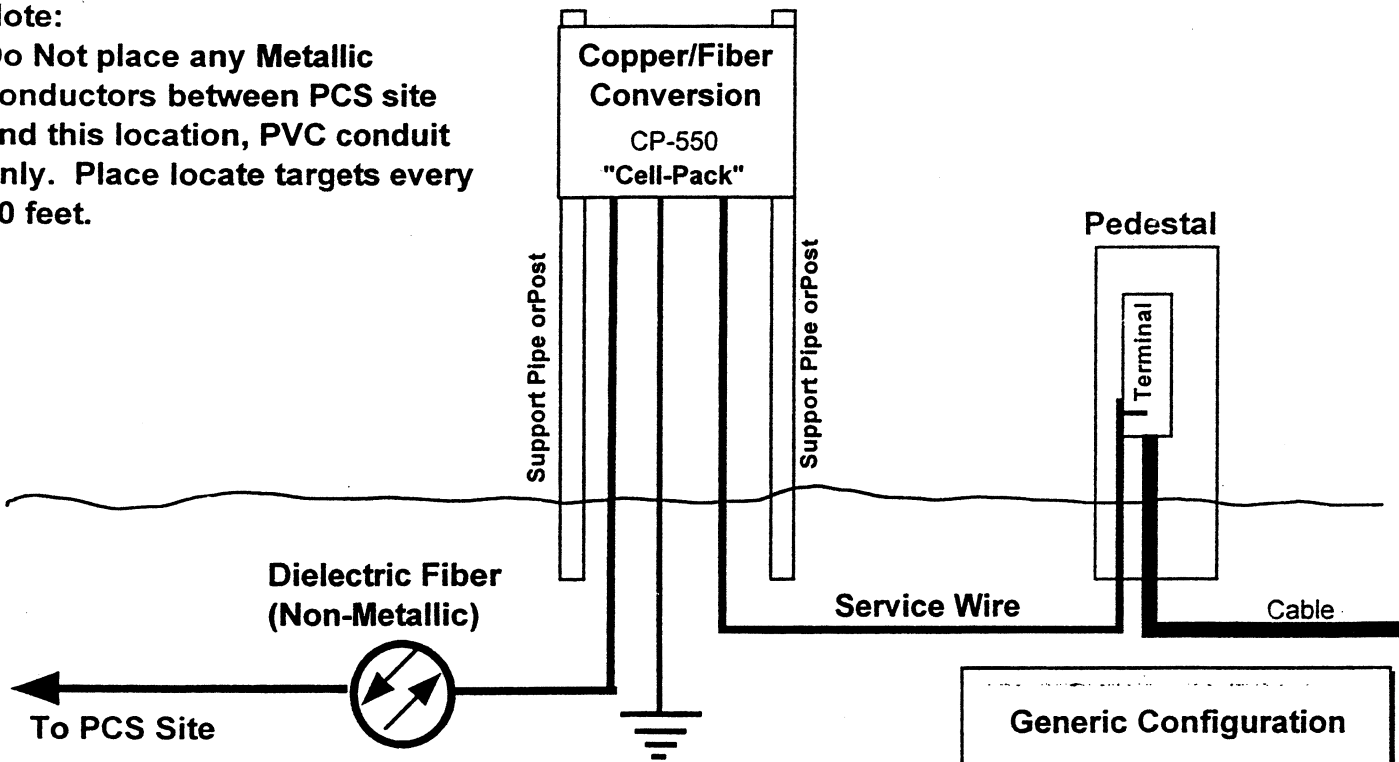

**Remote Unit**  
(Central Office End)  
**Buried Application**

**Generic Configuration**

**Copper-to-Fiber  
Conversion Equipment**

**U S WEST  
Provided**

**Notes:**

RJ-48 demark is in the CP-504 Cell Pack.

Line power of CPE is permitted for High Voltage Protection situations only. Option NIU card for "through power".

CP-504 Cell Pack must be located at least 500 feet from the closest point on the power transmission line.

If the circuit terminates near a power substation, the substation Zone of Influence must be calculated prior to the design being issued.

**Generic Configuration**  
**Copper-to-Fiber**  
**Conversion Equipment**  
**Customer-Provided**

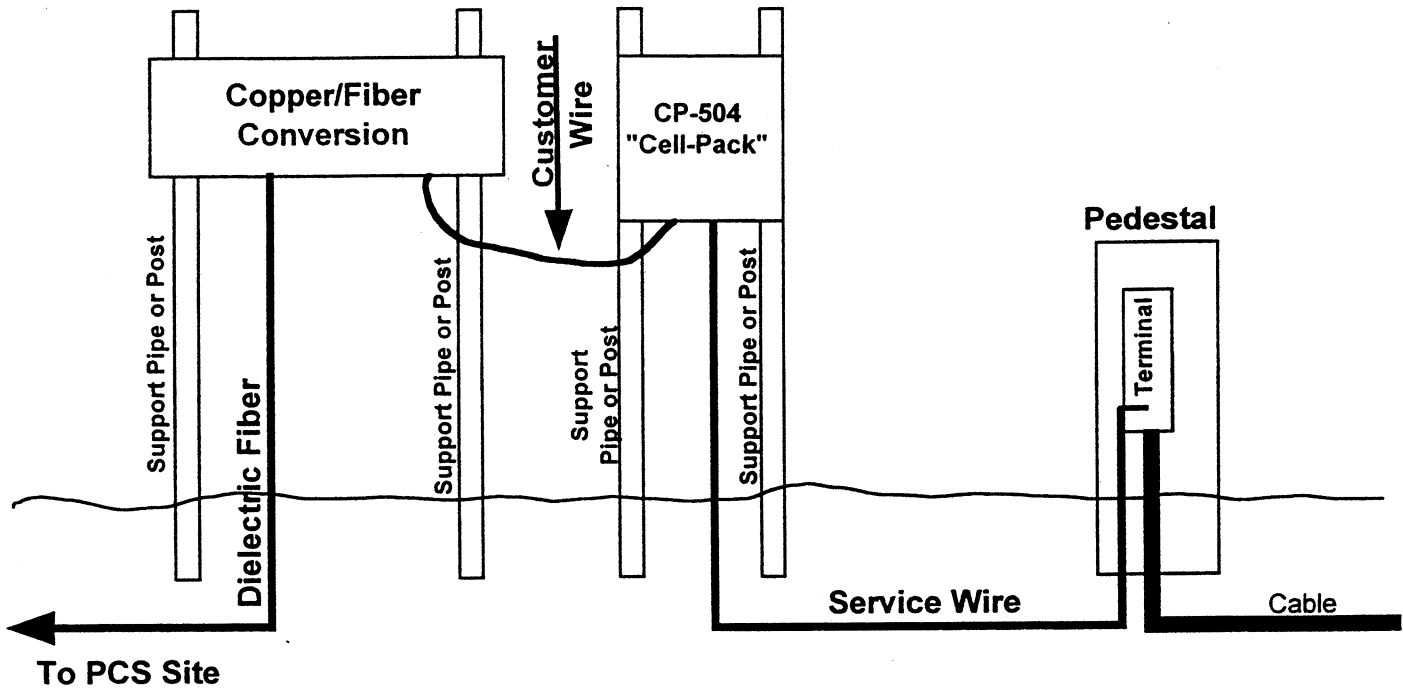

**Buried Application**

# Tower Safety

Four inches of physical separation between C.O. identity and Station identity.

Rubber insulating blanket is mandatory.

Rubber insulating gloves are mandatory.

DO NOT simultaneously contact C.O. identity and Station identity.

High Voltage may appear at any time without warning.

# Inclement Weather

DO NOT work on site during lightning storms. Transmission lines are very susceptible to lightning.

Be aware of your surroundings.

- A wet rubber blanket becomes ineffective.
- Ice or snow on insulators may lead to a fault.
- Equipment is not weatherproof...do not let rain or snow in.
- Wind may cause lines to slap together causing a fault.

**Inattention may be hazardous!**

# 2007 NESC® CHANGES NEWSLETTER

Issue 3 of 8

www.marneassociates.com

November 2006

## McGraw-Hill's NESC® 2007 Handbook

A welcomed companion to the NESC®, McGraw-Hill's National Electrical Safety Code® (NESC®) 2007 Handbook, authored by David J. Marne, PE, has been published and is available for purchase at [www.codehandbook.com](http://www.codehandbook.com).

## Focus on Changes

This month we are focusing on new Rule 230B titled "Ice and wind loading for clearances" and modified Rule 235I titled "Clearances in any direction from supply line conductors to communication antennas in the supply space attached to the same supporting structure."

### New Rule 230B, Ice and wind loading for clearances

New Rule 230B defines the ice and wind loads that must be put on an overhead line before checking overhead line clearance. To understand why this rule was added, it is necessary to understand the structure of the NESC Committees. Separate committees are responsible for overhead line clearance issues and overhead line strength issues. Prior to the 2007 NESC®, the overhead clearance rules relied on the strength rules to specify required ice and wind loads. During the past revision cycle, the clearance committee decided to copy the ice and wind loading map from the strengths section into the clearance section. Therefore, any changes to ice and wind loading requirements for strength purposes would not affect ice and wind requirements for clearance purposes. The bottom line is that the Heavy, Medium, and Light loading map from Rule 250B was copied to new Rule 230B and the terms Heavy, Medium, and Light were replaced with the terms Zone 1, Zone 2, and Zone 3. This is primary a formatting change and does not directly change the overhead line clearance values in Section 23.

### Revised Rule 235I, Clearances in any direction from supply line conductors to communication antennas in the supply space attached to the same supporting structure

Rule 235I provides clearance between supply conductors and communication antennas mounted in the supply space. It has become somewhat common to see a cell phone antenna mounted at the top of a power pole above the supply conductors in the supply space. Rule 235I references specific rows in NESC Table 235-6 to obtain the required clearance values between the antenna and the supply conductors. Typically, a communications vertical riser would be located on the pole that has a communications antenna. Requirements for vertical communication conductors passing through the supply space on jointly used structures (poles) are found in Rule 239H. When a communications antenna is located in the supply space, the worker installing or maintaining the communications antenna must be qualified to work in the supply space per the Work Rules (Sec. 42 and 44) of the NESC.

The revision to Rule 235I involves the addition of a note referencing new Rule 420Q. New Rule 420Q addresses the Radio Frequency (RF) emissions from communication antennas. This concern is an issue for power linemen working in the vicinity of cell phone antennas. Additional clearance or a RF disconnect switch may be required to protect workers from excessive radiation levels. The NESC® does not provide specific distances for working around communication antennas but does reference other standards that do.

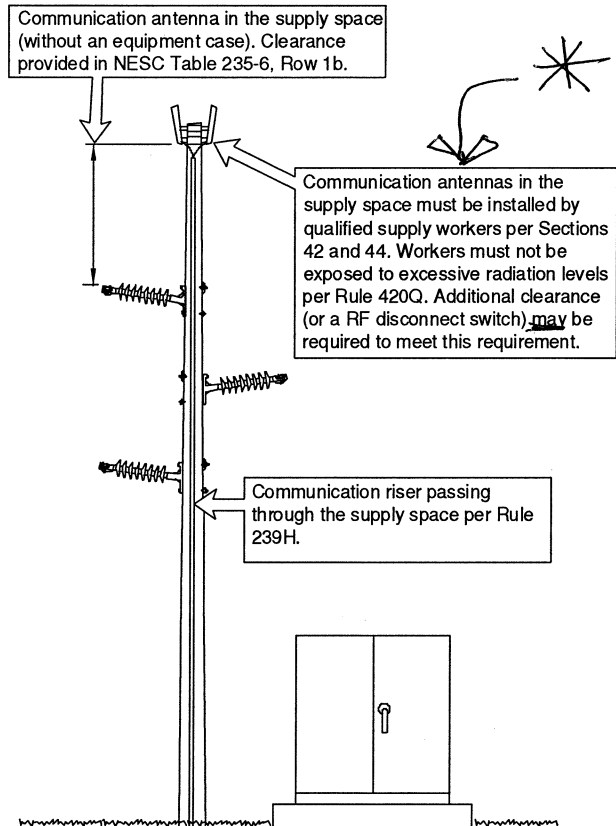

## Training Options

During the months of November and December, Marne and Associates will be presenting a one-day seminar entitled *Major Changes and General Overview of the 2007 NESC®* at the following locations:

### November Schedule

**Dallas** on November 9, 2006

**Las Vegas** on November 30, 2006

### December Schedule

**Little Rock** on December 12, 2006

**Houston** on December 14, 2006

Please visit [www.marneassociates.com](http://www.marneassociates.com) to register for any of our training sessions.

National Electrical Safety Code® and NESC® are registered trademarks of the Institute of Electrical and Electronics Engineers (IEEE).



Attachment C, Item 6  
Please See Attachment C, Item 2

~~Item E~~

Attachment C

Item ~~B~~ 17

- All installation and maintenance work involving antennas constructed above supply lines would be performed by Qualified Electrical Workers.
- Antennas are not recognized as a separate “Class” in GO 95 and are not included in the Class C circuitry definition.
- The portion of the pole or pole extension above supply lines will still be designated as “supply” space even when occupied by a third party antenna.
- The portion of the pole or pole extension above communication lines will still be designated as “communication” space” even when occupied by a third party antenna.
- The space above supply and communication lines will only be occupied by mutual agreement.
- Applicable to distribution structures supporting lines energized up to 50 kV.

Non-binding straw poll at April General Meeting – Accept these Proposed Rule Changes, pending wireless carrier’s investigation into availability of “suitably insulated” coaxial cable and ground wires.

## General Order Rule 94. X - Pole Top Antennas

### 94.X Pole Top Antennas

#### A. General Requirements

Antennas installed above supply and/or communication lines of different ownership shall be constructed in accordance with this and all applicable GO 95 rules.

#### B. Material Strengths

1. Antennas and associated elements installed above supply lines shall be constructed to Grade A requirements.
  - a. Pole top extensions supporting Antennas and associated elements above supply lines must be climbable and shall conform to the strength requirements for a whole pole. (See Rule 49.1-A)
2. Antennas and associated elements installed above communication lines shall be constructed to at least Grade F requirements.

#### C. Clearances

1. Antennas and associated elements installed above supply and/or communication lines of different ownership shall meet the vertical clearances specified in Rule 38, Table 2, Case 13a, Columns A - G.

Note: Other vertical clearances between communication equipment and supply lines are specified in Rule 92.1-F (2).

2. Clearance from unattached supply and/or communication lines shall be maintained in accordance with the requirements in Rule 38, Table 2, Case 3.

#### **D. Climbing Space**

1. Climbing space above supply lines shall be in accordance with Rule 54.7-A and maintained to:
  - a. The bottom of an Antenna or associated elements if the Antenna is affixed less than eight inches from the face of the pole; or
  - b. The top of the pole if an Antenna or associated elements are affixed more than eight inches from the face of the pole.
  - c. The uppermost Antenna or associated elements when multiple Antennas are affixed.
2. Climbing space above communication lines shall be in accordance with Rule 84.7 and maintained to:
  - a. The bottom of an Antenna or associated elements if the Antenna is affixed less than eight inches from the face of the pole; or
  - b. The top of the pole if an Antenna or associated elements are affixed more than eight inches from the face of the pole.
  - c. The uppermost Antenna or associated elements when multiple Antennas are affixed.

#### **E. Working Space**

1. Vertical and horizontal working space above supply lines shall be maintained in accordance with the requirements in Rule 54.7 –B.

#### **F. Stepping (See Rule 91.3 A - B.)**

#### **G. Transitions**

1. The construction requirements for Antenna cables and grounds transitioning thru Supply space shall meet Rule 87.11 specifications and riser shall not terminate:
  - a. Less than 3 ft. above and 6 ft. below supply lines where the upper most circuit is energized from 0 – 750 Volts; or
  - b. Less than 5 ft. above and 6 ft. below all supply lines where circuits are energized from 750 – 50,000 Volts.
2. Antenna cables and ground wires transitioning thru Communication Circuits shall meet Section VIII requirements.



## DRAFT – GO 95 RC Wireless Workgroup

### *Associated Rule Changes*

#### **New GO 95 Rule 87.11-A**

#### **87.11 Cable Transitions**

##### **A Cable Transitions**

(1) Transitions of cables between the supply level and communication level, or between one supply level and another supply level, shall occur on a single supporting structure.

(2) Cables transitioning from a supply level to a communication level, or from one supply level to another supply level, shall be treated in accordance with Rule 54.6-D, 1, 2, 3, and 5, at the supply level and transitioning to or through (e.g., vertical runs or risers) another level. When such cable is suitably insulated and suitably protected, there is no minimum clearance from centerline of pole or from other conductors except such cables shall not be installed in the climbing space.

(Note: Suitably insulated as used in this Rule applies to the highest phase-to-ground supply voltage transitioned.)

**Exception:** Cables associated with supply antennas transitioning from a supply level to another supply level may be treated in accordance with Rule 54.6-D (4). Uncovered, grounded, cable transitions in vertical runs on metallic structures shall also maintain minimum clearances in accordance with Rule 38, Table 2, Case 16a.

(3) Splices and splice enclosures on cable transitions shall meet the requirements for equipment of Rule 54.4-G.

#### **Revised GO 95 Rule 54.7-B (2)(g)**

#### **54.7 Climbing and Working Space**

##### **B Working Space (All types of Construction)**

##### **(2) Allowable Working Space Obstructions**

(g) Pole top antenna lead-in wires, drip loops or incidental wiring shall not extend more than 12 inches into the working space.

**Revised Rule 91.3-B**

**91.3 Stepping**

**B Location of Steps**

The lowest step shall be not less than 7 feet 6 inches from the ground line and above this point steps shall be placed, with spacing between steps on the same side of the pole not exceeding 36 inches, at least to that conductor level above which only circuits operated and maintained by one party remain. Steps shall be so placed that runs or risers do not interfere with the free use of the steps.

Exception: Steps are not required in designated supply space when antennas are mounted above supply conductors.

**Revised Rule 92.1-F (2)**

**F Between Conductors, Cables, Messengers and Miscellaneous Equipment**

(1) **Unenergized Parts of Energized Equipment:** Communication conductors or 0 – 750 volt supply conductors, of different ownership, which are either supported 15 inches or more from center line of pole, or are attached to the surface of a pole and provided with a guard arm, shall be 48 inches or more below the un-energized parts, cases or enclosures of the energized apparatus of the other classification.

Note: Revised November 6, 1992 by Resolution SU-15.

(2) **Cable Terminals or Metal Boxes:** On jointly used poles all parts of metal communication cable terminals, metal boxes or similar equipment shall maintain vertical clearances from conductors not less than the clearances specified in Rule 38 Table 2, Col. C, Cases 8 to 13 inclusive.

EXCEPTION: The minimum vertical distance between all parts of such metal terminals, boxes or similar equipment which are 8 inches or more from the center line of pole and are supported by cable and/or messenger alone can be reduced to not less than 1 inch by mutual agreement between the affected owners (see Rule 38, Table 2, Case 8, Column C).

For clearances between street light drop wires and cables, other conductors, and metal boxes see Rules 58.5-B3 and 92.1-F5.

For clearances between antennas, communication cables and other conductors see Table 2, Case 13a, Columns A – G.

DRAFT – GO 95 RC Wireless Workgroup

Rule 38, Table 2, New Case 13a

Case No.	Nature of Class and Class and Voltage of Wire, Cable or Conductor Concerned	A Span Wires, Guys and Messengers	B Trolley Contact Conductors 0-750 Volts	C Communication Conductors (Including Open Wire, Cables and Service Drops	D 0-750 Volts (Including Service Drops) and Trolley Feeders (a)	E 750 - 7,500 Volts	F 7,500 - 20,000 Volts	G 20,000 - 35,000 Volts	H 35,000 - 75,000 Volts	I 75,000 - 150,000 Volts	J 150,000 - 300,000 Volts
13a	<u>Pole top antennas and associated elements on joint use poles (tt)(ww)</u>	24	48	24 (uu)	48	72	72	72	72 (vw)	-	-

- (tt) Clearances for supply antennas from supply and communication lines ..... 58.6 and 54.4-G
- (uu) May be reduced to 10 in. for cables installed/operated by antenna owner ..... 92.1-F(2)
- (vv) Up to 50 kV
- (ww) For antenna incidental wiring clearances. see 54.7-B(2)(g)

*Attachment C, Item 3*

ALJ/GEW/avs

DRAFT

Agenda ID # 6082(Rev. 1)

Quasi-Legislative

11/9/2006 Item 30

Decision PROPOSED DECISION OF ALJ WALKER (Mailed 10/10/2006)

**BEFORE THE PUBLIC UTILITIES COMMISSION OF THE STATE OF CALIFORNIA**

Order Instituting Rulemaking to Revise  
Commission General Order Number 95 pursuant  
to D.05-01-030.

Rulemaking 05-02-023  
(Filed February 24, 2005)

(See Appendix A for list of appearances)

TABLE OF CONTENTS

Title	Page
OPINION ADOPTING PROPOSED RULE 94 IN GENERAL ORDER 95 DEALING WITH INSTALLATION OF WIRELESS ANTENNAS ON UTILITY POLES .....	2
1. Summary .....	2
2. Procedural Background .....	3
3. Commission Jurisdiction .....	5
4. Rule 94 Alternatives .....	6
4.1 Proposal 1 for Rule 94 .....	7
4.2 Proposal 2 for Rule 94 .....	7
4.3 Proposal 3 for Rule 94 .....	8
5. Disputed Provisions .....	8
5.1 Pole-Top Antennas .....	9
5.2 Powering Down Wireless Antennas .....	10
5.2.1 Power-Down Procedure .....	13
5.3 Signage Identifying RF Exposure Limits .....	14
5.4 Vertical Clearance Level .....	17
5.5 Antenna Exceptions .....	20
6. Jurisdictional Challenge .....	21
6.1 Discussion .....	26
7. The Proposed Settlement .....	28
8. Conclusion .....	30
9. Implementation of Rule Changes .....	32
10. Annual Reporting Requirement .....	32
11. Comments on Proposed Decision .....	34
12. Assignment of Proceeding .....	36
Findings of Fact .....	36
Conclusions of Law .....	38
ORDER .....	39
Appendix 1	
Appendix 2	
Appendix A	

**OPINION ADOPTING PROPOSED RULE 94 IN  
GENERAL ORDER 95 DEALING WITH INSTALLATION  
OF WIRELESS ANTENNAS ON UTILITY POLES**

**1. Summary**

The Commission on February 24, 2005 issued this Order Instituting Rulemaking (R.) 05-02-023 to consider uniform rules for attaching wireless antennas to jointly used utility poles. Following seven days of workshops in San Francisco and Los Angeles, the parties jointly presented a workshop report containing three alternative proposals for a new Rule 94 to General Order (GO) 95. Evidentiary hearings were conducted in February 2006, to take testimony on which provisions of the three proposed rules should be adopted by the Commission. A Proposed Decision that was issued in April 2006 adopted in its entirety the Rule 94 sponsored by the Commission's Consumer Protection and Safety Division (CPSD), the International Brotherhood of Electrical Workers Local 1245 (IBEW), the Communication Workers of America-Ninth District (Communication Workers), Pacific Gas and Electric Company (PG&E) and San Diego Gas & Electric Company (SDG&E).

Before the Commission acted on that Proposed Decision, 16 parties moved to set aside submission so that the parties might consider a settlement agreement. The motion was granted and, on August 23, 2006, the parties filed a settlement agreement that would delete two provisions of the new Rule 94 (additional signage for certain antennas and methods of de-energizing antennas when necessary) and require the signing parties to meet essentially the same requirements in private agreements between joint pole owners and wireless antenna owners. The proposed settlement is endorsed by virtually all parties, including the union parties and CPSD, and no party opposes it. This decision adopts the amended Rule 94 and approves and adopts the settlement agreement.

The new Rule 94 and the settlement agreement are attached to this decision as appendices. The decision also imposes an annual reporting requirement on all public utilities subject to Commission jurisdiction that have poles upon which wireless carrier RF antennas may be installed. This proceeding is closed.

## **2. Procedural Background**

On October 2, 2001, the Commission issued R.01-10-001 to revise GO 95 and GO 128, which govern, respectively, the construction of overhead and underground electric supply and communications systems. Commission staff, industry representatives, labor organizations and the public conducted 16 months of twice-monthly two- to three-day public workshops throughout California. A total of 63 proposed changes to existing rules were considered. Of these, 40 were supported by consensus of the workshop participants, 15 were withdrawn, and eight were in dispute.

On January 13, 2005, the Commission issued Decision (D.) 05-01-030. The Commission adopted the 40 proposed rule changes supported by consensus, noted the 15 withdrawn proposed rule changes, and discussed and resolved seven of the eight disputed proposed rule changes. The Commission, however, was unable to resolve all issues surrounding the proposal to add a new rule to GO 95 to establish uniform construction standards for attaching wireless antennas to jointly used poles. Thus, in D.05-01-030, the Commission directed staff to further investigate the issues raised by the wireless antenna rules in this new rulemaking proceeding.

A prehearing conference (PHC) in this proceeding was conducted on May 24, 2005, and the parties agreed to hire a facilitator, as they had done in the earlier proceeding, and to conduct workshops aimed at achieving consensus on wireless antenna rules.

On June 7, 2005, a Scoping Memo and Ruling of the Assigned Commissioner determined that this is a quasi-legislative proceeding and set the evidentiary hearing schedule.

Seven days of workshops were held in San Francisco and Los Angeles. Approximately 40 to 70 participants representing 20 parties attended each workshop. While there was substantial agreement on the majority of rules governing wireless antennas, the parties were unable to reach consensus on all issues.

Accordingly, on September 12, 2005, the parties submitted a joint workshop report that included three alternative proposals for a new Rule 94, along with position statements of the parties. At a second PHC on November 14, 2005, the parties scheduled evidentiary hearings that were conducted on February 7-9, 2006. At hearing, the Commission heard from nine witnesses and received 22 exhibits into evidence. Briefs were filed on March 13, 2006, and reply briefs were filed on March 28, 2006, at which time the rulemaking was deemed submitted for Commission decision. A Proposed Decision was issued on April 25, 2006.

Before the Commission acted on the Proposed Decision, several parties on July 18, 2006, filed a joint petition to set aside submission pursuant to Rule 84 of the Rules of Practice and Procedure to allow the parties to pursue settlement discussions. The petition was granted on July 20, 2006. On August 23, 2006, a



settlement agreement was proposed by 16 of the parties, including CPSD and the two union parties.<sup>1</sup> A settlement hearing to consider the proposal was conducted on September 12, 2006, at the conclusion of which this matter was re-submitted for Commission consideration.

### **3. Commission Jurisdiction**

GO 95 rules concern the safety of the general public, utilities' customers and utilities' employees. As required by the Public Utilities Code, "[e]very public utility shall furnish and maintain such adequate, efficient, just, and reasonable service, instrumentalities, equipment, and facilities ... as are necessary to promote the safety, health, comfort, and convenience of its patrons, employees, and the public." (Pub. Util. Code § 451.) As part of the Commission's jurisdiction over public utilities in California, we are authorized to "do all things, whether specifically designated in [the Public Utilities Code] or in addition thereto, which are necessary and convenient" in the supervision and regulation of every public utility in California. (*Consumers Lobby Against Monopolies* (1979) 25 Cal.3d 891.) The Commission's authority has been liberally construed. (See, e.g., *People v. Superior Court* (1965) 62 Cal.2d 515; *People v. Western Air Lines, Inc.* (1954) 42 Cal.2d 651; see also Pub. Util. Code § 701.)

---

<sup>1</sup> Sponsors of the settlement agreement are CPSD, IBEW, the Communication Workers, PG&E, AT&T California, California Cable & Telecommunications Association, Clearlinx Network Corporation, Crown Castle USA, Inc., New Cingular Wireless PCS, LLC, NextGNetworks of California Inc., Omnipoint Communications, Inc., dba T-Mobile, Southern California Edison Company, Sprint Nextel, Verizon California Inc., Verizon Wireless and William Adams. SDG&E, which owns its own poles and has consistently enforced a higher standard, declined to join the Settlement. It does not, however, oppose it. Similarly, the California Municipal Utilities Association is not a signatory but does not oppose the settlement.

This Commission has comprehensive jurisdiction over questions of public health and safety arising from utility operations. (*San Diego Gas & Electric v. Superior Court* (“Covalt”) (1996) 13 Cal.4th 893, 923-924.) Our jurisdiction to regulate these entities is set forth in the California Constitution and in the Public Utilities Code. (Cal. Const., Art. 12 §§ 3, 6; Pub. Util. Code §§ 216, 701, 1001; see also, *Order Instituting Investigation Into the Power Outage Which Occurred on December 8, 1998 on Pacific Gas & Electric System*, Investigation 98-12-013 resulting in D.99-09-028, at 7-8.) Such utilities are required to “obey and comply with every order, decision, direction, or rule made or prescribed by the [C]ommission ....” (Pub. Util. Code § 702; see also, §§ 761, 762, 767.5, 768, 770.) The Commission is obligated to see that the provisions of the Constitution and state statutes affecting public utilities are enforced and obeyed. (Pub. Util. Code § 2101.)

#### **4. Rule 94 Alternatives**

All parties agree that GO 95 does not today contain specific rules for the installation of wireless antennas on utility poles that bear overhead lines. This is because, until recently, relatively few antennas had been installed on these utility poles. All parties agreed that uniform rules governing the installation of wireless antennas on jointly owned utility poles should be part of GO 95. As a result of their workshops, the parties presented us with three alternative proposals, which we briefly discuss below.<sup>2</sup>

---

<sup>2</sup> Another rule labeled Proposal 2A was offered by the California Municipal Utilities Association (CMUA) in its reply brief on March 28, 2006. Proposal 2A was a composite of sections from Proposals 1 and 2, most of which were unopposed.

#### **4.1 Proposal 1 for Rule 94**

Proposal 1, which was adopted in its entirety in the Proposed Decision that was issued on April 25, 2006, was sponsored by CPSD, IBEW, the Communication Workers, PG&E and SDG&E. It added a definition of antennas to Rule 20 of GO 95 ("a device for emitting and/or receiving radio frequency signals") and proposed a new Rule 94 requiring that antennas meet standards applicable to Class C communications equipment; maintain a vertical clearance of 6 feet from supply (electrical) conductors operating at 0-50 kilovolts and clearances of 2 feet (vertical) from communications conductors and (horizontal) from the centerline of the pole; provide a sign identifying the antenna and providing information if the antenna exceeds certain Federal Communications Commission (FCC) exposure limits, and provided a means of controlling or shutting down wireless antennas if necessary. Antennas used by utilities for monitoring their supply system and antennas attached to communication cables would be exempt from Rule 94, although they must comply with other GO 95 requirements.

#### **4.2 Proposal 2 for Rule 94**

Proposal 2 was sponsored by Southern California Edison Company (SCE). It was supported by Crown Castle USA, Inc.; Cingular Wireless; NextG Networks; Sprint Nextel; Omnipoint Communications, Inc. dba T-Mobile; and Verizon Wireless (collectively, the Wireless Group). Its definition of "antenna" and its requirement that antennas meet the circuit requirements of Class C equipment mirrored the requirements of Proposal 1. It made optional the installation of a power-reduction or disconnect device; provided for a vertical separation of 2 feet from communication conductors and a 2-foot horizontal clearance from the face of the pole when supported by a cross arm, and a

clearance from supply conductors of 4 to 6 feet as specified in GO 95 tables. At hearing, all parties stipulated that Proposal 2 could be amended to include provision 94.5 of Proposal 1 (a sign identifying the type of antenna and providing a 24-hour contact number), but not provision 94.6 of Proposal 1 (signage identifying the FCC's calculated minimum approach distance when applicable).

#### **4.3 Proposal 3 for Rule 94**

Proposal 3 was sponsored by William P. Adams, an intervenor in this proceeding. Adams is an electrical engineer who retired in 1990 after 22 years with the Commission. His proposal essentially mirrored Proposal 1 as to clearances between wireless antennas and power and communications conductors, and was similar to Proposal 2 in requiring that the antenna operator be responsible for powering down or shutting down a wireless antenna. Proposal 3 was the only proposal to provide for wireless antennas on the top of a utility pole, although at hearing Adams recommended that pole-top provisions be deferred. In his reply brief, Adams essentially withdrew his Proposal 3, instead supporting Proposal 2.<sup>3</sup>

#### **5. Disputed Provisions**

The parties had few disputes remaining about the provisions of new Rule 94, and even those disputes were narrowed at hearing. The following issues were unresolved:

- Should pole-top antenna requirements be made part of Rule 94 in this proceeding?

---

<sup>3</sup> Adams proposes one addition to Proposal 2, stating that if a disconnect device is installed, it "be protected from unauthorized operation by suitable means." (Adams Reply Brief, at 2.)

- Should Rule 94 make provision for a method of disconnecting or powering down the emission levels of RF antennas?
- Should a wireless carrier be required to post signage identifying the FCC exposure limits when applicable for its installed antennas?
- Should a uniform six-foot vertical clearance level between wireless antennas and supply conductors be expressly required?
- Should there be express exceptions for utility supply antennas and cable-embedded antennas?

### **5.1 Pole-Top Antennas**

A proposed rule addressing the potential issues surrounding pole-top installations is not before the Commission, since the provision suggested by intervenor Adams has been withdrawn. Adams earlier asked that his recommendation on this subject be deferred. His comment followed testimony by SCE witness Samuel B. Stonerock, who is also chairman of the GO 95/128 Rules Committee (Rules Committee). The Rules Committee is comprised of California supply and communications professionals knowledgeable in the application of GO 95 and GO 128. It meets regularly to consider and make recommendations on these technical rules. Stonerock testified that the Rules Committee “engaged in lengthy and often vigorous discussions” on pole-top issues at its meeting held December 6-8, 2005, and was to begin voting on a draft pole-top rule at its Northern California meeting in April 2006. A further consensus vote was planned for later in the year in Southern California. He added that the proposed rule, if adopted by the Rules Committee, would involve changes to several provisions of GO 95 and would be brought before the Commission in a separate proceeding.

The proposed rules on pole-top installations of RF antennas are complex, involving such technical concerns as pole strength, coaxial cable provisions, clearances, and the location above electrical equipment. One concern is that antenna installers must pass through or near high-voltage equipment to reach the pole top, since supply (electric) facilities are located in the upper part of a pole, while communications facilities are located lower on the pole. Only qualified electrical workers are permitted to enter the upper area of the pole. Because of these considerations, all parties (with one exception) urge that the Commission defer consideration of pole-top antennas and await the guidance of the Rules Committee later this year.<sup>4</sup> Since we have no record before us on this issue, we agree that deferral is prudent and necessary.

## **5.2 Powering Down Wireless Antennas**

The FCC in 1985 adopted guidelines to be used in evaluating human exposure to RF emissions, and these guidelines were revised and updated in 1996.<sup>5</sup> The guidelines incorporate limits for Maximum Permissible Exposure (MPE) for two categories of persons: general population/uncontrolled (*i.e.*, “[f]or FCC purposes, applies to human exposure to RF fields when the general public is exposed or in which persons who are exposed as a consequence of their employment may not be made fully aware of the potential for exposure or cannot exercise control over their exposure”)<sup>6</sup> and occupational/controlled

---

<sup>4</sup> ClearLinx Network Corporation urges the Commission to “mandate that wireless antennas may be placed at the top of utility poles and that (to the extent it is technically feasible) all ancillary equipment may be attached to utility poles.” (ClearLinx Opening Brief, at 16.)

<sup>5</sup> See *Report and Order*, ET Docket 93-62, FCC 96-326, 61 Federal Register 41,006 (1996).

<sup>6</sup> FCC OET Bulletin 65, Definition and Glossary of Terms, at 3.

(i.e., “[f]or FCC purposes, applies to human exposure to RF fields when persons are exposed as a consequence of their employment and in which those persons who are exposed have been made fully aware of the potential for exposure and can exercise control over their exposure”).<sup>7</sup> If a wireless antenna complies with the FCC’s general population/uncontrolled MPE limit, the FCC does not require a wireless operator to take any action to limit potential exposure. If the potential for RF exposure exceeds the limit applicable to workers who risk exposure in the course of their employment, the FCC proposes alternative methods to ensure that no individual is exposed to RF beyond such limits. In its OET Bulletin 65, issued in 1997 by the FCC’s Office of Engineering and Technology (OET), the FCC suggests a number of ways to control RF exposure.

These include restricting access to the RF-emitting devices (often with fences), limiting access on a time-averaging basis to a few minutes at a time, wearing RF protective clothing, and “reducing or shutting off power when work is required in a high RF area.” (Exhibit 3, OET Bulletin 65, at 56.)

Prior to the settlement agreement (which resolved the de-energizing issue for those entities that are signatories), Proposal 1 in this proceeding required a means of reducing or shutting off antenna power (such as a disconnect switch) on or near the utility pole on which a wireless antenna is located if the antenna exceeded the general population/uncontrolled MPE limits. (The majority of RF antennas do not exceed the MPE limits, and thus a disconnect switch would not be required for most RF antennas.) Proposal 2 would make a disconnect switch optional, but it specified a location outside the

---

<sup>7</sup> FCC OET Bulletin 65, Definition and Glossary of Terms, at 4.

climbing space and no less than 6 feet from the ground if such a device is installed.

In his opening testimony, CPSD witness Raymond Fugere testified that a jointly used pole presents a unique working environment because workers are unable to move freely away from the sources of RF exposure. He added:

Supply and communication workers need to be able to either power down or turn off an antenna that is exposing the workers to higher RF radiation, as specified by the FCC. Since it is not practical under many circumstances for workers to use other methods of lessening exposure to harmful RF radiation levels, such as time averaging, this is the best means of protecting workers from a potentially harmful situation. (Exhibit 1, at 9.)

Fugere testified that an immediate means of reducing power is particularly important in emergency situations, such as a car-pole accident, downed power lines, or fire, where a pole worker must have sufficient working space to quickly accomplish a repair. He noted that crews today have the ability to shut down high-voltage lines at critical locations when required in an emergency.

By contrast, the Wireless Group's RF expert, Dale Hatfield, testified that in his opinion the FCC rules give authority to reduce or turn off the power for an RF antenna only to the antenna owners and precluded state action that would alter that authority. On cross-examination, however, he agreed that if a pole worker is unable to leave an area where there is RF exposure above the general population/uncontrolled limits, a means of actually controlling the exposure level, such as reducing the power or shutting down, would be necessary. He also agreed that OET Bulletin 65 states that reducing or shutting off power is an



engineering control preferred over RF protective clothing. He suggested that antenna owners and utilities work together to establish power-down procedures.

Marc Brock, a PG&E technical support specialist, testified that PG&E has procedures in place that require a power shutoff device in a lockbox on or near the pole when wireless antennas are installed. In emergency situations, he said, crews will first try to contact the antenna owner and, if that effort is unsuccessful, the crew is authorized to go into the lockbox and shut down the antenna power if the antenna would intrude on the crew's ability to work on the pole. IBEW in its reply comments stated that wireless antennas in Northern California are constructed primarily on towers and have a de-energizing switch by agreement with tower owners.

The evidence presented at hearing supports the need for a locally controllable means of reducing or shutting off antenna power when that is necessary to enable pole workers to work on the pole, just as there are power-off devices in place today for shutting down high-voltage power in the event of an emergency. The purpose of such a rule is not to interfere with RF transmissions but, rather, to quickly enable a pole worker to have sufficient working space between pieces of equipment to do a job safely. The Wireless Group based its opposition to this provision of Proposal 1 solely on jurisdictional grounds. We discuss the jurisdictional issue in Section 6 of this decision.

#### **5.2.1 Power-Down Procedure**

Wireless carriers reasonably argue that antenna owners should be called before antenna power is reduced or shut down in all but the most serious emergencies. They note that a loss of power can interfere with cell phone use, including emergency calls to police, fire, and other emergency personnel. They add that antenna owners, if notified before power is reduced, can increase power

in adjacent antennas, effectively re-routing the cell phone signal so that interruption is avoided or minimized. A major concern of cellular carriers throughout the proceeding has been avoiding unplanned disruptions in service.

As noted, a locally verifiable means of reducing or shutting off antenna power is only required on those antennas for which the FCC requires protective measures, since only these RF antennas present a climbing obstacle that can force a lineman to climb too close to high-voltage equipment. The record suggests that most RF antennas are below that exposure level, presenting no significant climbing obstruction. Nevertheless, at least some RF antennas are affected by the rule and, with anticipated growth of cell coverage in less populated areas, more could be in the future.

We agree that utility pole owners should develop procedures by which antenna owners would be called before power to an RF antenna is reduced or disconnected to remove the climbing hazard. Normally, such disconnect procedures are negotiated in the contracts between pole owners and antenna owners. PG&E, for example, requires its line crews to call an antenna owner before opening a power-down lockbox and reducing or cutting power except in exigent circumstances. Other utilities adopt similar procedures in their contracts with antenna owners. As discussed below, the settlement agreement addresses and resolves this issue as to its signatories.

### **5.3 Signage Identifying RF Exposure Limits**

After a long period of opposition, the Wireless Group announced at hearing that it no longer opposed the requirement in Proposal 1 that each antenna installation be marked with a sign that identifies the antenna operator, provides a 24-hour contact number of the antenna operator for emergency or information, and provides a unique identifier for the type of antenna installed.

However, the Wireless Group continued to oppose Section 94.6 (Identifying Exposure) of Proposal 1. That provision stated:

Antennas that comply with the FCC's General Population/Uncontrolled maximum permissible exposure limits shall have a sign that provides information on such compliance.

Antennas that exceed the FCC's General Population/Uncontrolled maximum permissible exposure limits shall have a sign that provides the calculated minimum approach distance.

The antenna operator shall locate the sign prominently in areas below the antenna that are visible from the climbing space and the bottom of the sign shall not be lower than nine feet above ground line.

CPSD witness Fugere testified that the additional signage is necessary because a worker cannot tell simply by looking at an antenna whether it is emitting RF radiation under the general population/uncontrolled limit or the more restrictive occupational/controlled limit. If an antenna's emissions are within the lower general population/uncontrolled level, then only that statement would be required on the sign. If the emission level exceeds the general population/uncontrolled exposure limits (*i.e.*, falls into the occupational/controlled limits), then the sign would provide the calculated minimum approach distance designated by the FCC.

Fugere stated that "[i]n regard to worker safety, it's important for workers to be aware of how far away from the antenna they need to be when the antenna is operating under normal conditions in order to not be exposed to RF radiation exposure levels that exceed the FCC guidelines." (Exhibit 1, at 8.) The Wireless Group's FCC expert agreed that if a "piece of equipment forced the

worker to move within a distance that would exceed the allowable standard, whichever it is, that could be a problem.” (Transcript, at 254.)

The veteran linemen who testified all agreed that a sign with information about an antenna’s RF exposure levels would give them a way to determine whether they need to be concerned about their exposure level and how to proceed. They added that if such a sign was not present (because it had fallen off due to weather, vandalism or other causes), they could decide whether to seek further information before climbing the pole. The Wireless Group’s RF expert acknowledged that the FCC’s OET Bulletin 65 states that warning signs can be used to establish awareness as long as they provide information in a prominent manner on the risk of potential exposure. (Transcript, at 260.)

Witness Hatfield on behalf of the Wireless Group testified that the FCC rules leave it up to the wireless operator to determine the best practical means to comply with the FCC’s regulations and do not mandate particular methods in all circumstances. He added that the FCC rules do not mandate signs, but rather allow the wireless operators or employers to use various methods to provide awareness of and control RF exposure, based on the particular circumstances of the given exposure. On brief, the Wireless Group maintained that this Commission is preempted “from adopting the irreconcilable and significantly different approach of Proposal No. 1’s RF rules.” (Wireless Group Opening Brief, at 13.) The Wireless Group’s jurisdictional argument is addressed in Section 6 below.

There can be no question that the signage requirement in Proposal 1 would be a useful safety measure for workers who climb utility poles that support high-voltage distribution lines. The linemen who testified admitted to little knowledge of wireless antennas or RF exposure. One commented that a

colleague on one occasion simply threw a rubber blanket over a piece of equipment that may have been an antenna, even though such a blanket is intended to prevent electrical shock rather than protect against RF exposure. Another lineman, asked how he would identify a piece of equipment that might be an antenna, said that he would show it to his supervisor, who then would “walk out in the hallway and hold it up and say, ‘Has anybody ever seen one of these?’” (Transcript, at 152.)

Obviously, safety is served if pole workers are able to read a sign and, if warned that occupational/controlled limits of exposure applied, learn immediately how far they should position themselves from an antenna when they do their work on the pole. Since the Wireless Group has agreed to a requirement to post a sign identifying the antenna and providing a 24-hour contact number, it would not appear unduly burdensome to also identify the FCC standard by which RF radiation exposure is measured and, if necessary, the calculated minimum approach distance for the particular type of antenna. We conclude that the evidence supports the need for signage identifying exposure information. As discussed below, the settlement agreement adopts these procedures as part of the contracts between joint pole owners and antenna owners. No such requirement would obtain for those few utilities that are not signatories to the settlement agreement.

#### **5.4 Vertical Clearance Level**

Proposal 1 and Proposal 2 take different approaches to establishing vertical clearance requirements. Proposal 1 specifies a 6-foot vertical clearance requirement between antennas and supply conductors, including supporting elements of the equipment. (A supply conductor is one that carries electricity for the purpose of electric consumption, while a communication conductor carries

electricity for the purpose of sending a communications signal.) Proposal 2 relied on existing GO 95 requirements for Class C equipment, specifically Rule 92.1-F(2) and its references to Rule 38, Table 2, Column C, Cases 8-13. These provisions appear to require a 6-foot vertical clearance when high-voltage conductors are involved, but would permit a clearance of as little as 4 feet for lesser-voltage conductors, particularly when the antenna is mounted on a cross-arm.

The need for a uniform 6-foot vertical clearance was supported by the testimony of CPSD witness Fugere and three experienced linemen, Greg Walters of SDG&E, George Lindsey of IBEW, and PG&E witness Marc Brock. Fugere testified that a wireless antenna with a vertical clearance of 4 feet or less from supply conductors would create a physical obstruction for one working on a pole and would expose the worker to potential electrical shock. Walters cited a number of examples of when a 6-foot clearance would be necessary: (1) when maneuvering with an 8-foot "hot stick" to apply temporary grounds on energized conductors from a safe distance; (2) when climbing on a pole with a complicated configuration of supply conductors; (3) when installing permanent primary jumpers to tie related electric circuits, and (4) when working with other linemen, each about 6 feet tall, on energized primary conductors. In each case, Walters said, the pole worker "needs the 6 feet to be able to actually and comfortably and safely do his work." (Transcript, at 134.) Lindsey and Brock similarly urged a 6-foot vertical clearance, commenting that anything substantially less would make it more likely that a lineman could come into contact with a supply conductor, causing an electric shock that could be fatal.

Testifying in support of Proposal 2, SCE witness Stonerock contended that a careful reading of GO 95's Rule 92.1-F(2) and the referenced clearances in

Table 2, Column C, Cases 8-13, makes it clear that 6-foot vertical clearances are required under all conditions when a supply conductor is 7,500 to 75,000 volts or when it is less than 8 inches from the centerline of the pole, permitting 4-foot clearance only if the conductor is 0 to 7,500 volts and located 8 inches or more from the centerline of the pole. He added that this conforms to current requirements for Class C equipment. The Wireless Group, supporting Proposal 2, argued on brief that the proposal “continues GO 95’s tradition of developing consistent construction rules for similar types of equipment,” in this case, Class C communications equipment. (Wireless Group Opening Brief, at 16.)

As noted earlier, Stonerock is chairman of the GO 95/128 Rules Committee, and on the stand he displayed an almost encyclopedic knowledge of the relevant sections of the 556 highly technical pages of GO 95. There is no question that his interpretation of Rule 92.1-F(2) and its associated tables is correct. However, unless there is some way to graft his knowledge and experience onto the new antenna rule, it seems likely that others reading this provision of Proposal 2 could interpret it in a different and perhaps more flexible manner. Indeed, in its reply brief, SCE proposed to “clarify” the clearances provisions of Proposal 2, “(g)iven the dispute between the parties regarding clearances.” (SCE Reply Brief, at 4.) The clarification would have added a new subsection to specifically state vertical clearance distances between unprotected supply conductors and “all” antenna parts.

While we understand the desire of Proposal 2 proponents to apply vertical clearance requirements less rigidly in situations where there is little or no safety risk, we find that the clearance requirements of Proposal 1 better safeguard employees and provide clearer guidance to antenna installers, many of

whom are probably not thoroughly familiar with GO 95. As discussed below, the settlement agreement endorses the clearance requirements of Proposal 1.

### **5.5 Antenna Exceptions**

Proposal 1 states that antennas utilized solely for the operation and maintenance of utility supply systems, along with certain antennas mounted on cables, are not subject to the provisions of new Rule 94 because they are specifically governed by other provisions of GO 95. Witnesses testified that supply antennas, such as SCADA antennas,<sup>8</sup> are typically installed within the electric supply space of a distribution pole and therefore cannot meet the clearance requirements of Class C equipment. Moreover, according to PG&E witness Brock, supply antennas do not raise the same RF exposure concerns of wireless antennas since the RF exposure level from supply and cable-mounted antennas is usually less than the FCC's general population/uncontrolled levels. Electrical workers have the ability to turn off the supply antenna's power, if necessary.

SCE witness Stonerock testified that supply antennas are governed by specific provisions of GO 95, such as Rules 54.4-G and 58.6, and he did not include these antennas as exempt from Proposal 2 because such an exemption was unnecessary. To eliminate any doubt, he said that he would have no objection to including the exemption clause of Proposal 1 in Proposal 2.

The Wireless Group disagreed. It argued on brief that treating supply and strand-mounted antennas differently than wireless antennas is discriminatory. We find little merit in this contention. Strand-mounted antennas

---

<sup>8</sup> SCADA antennas are Supervisory Control and Data Acquisition antennas that monitor the performance of electrical circuits.



by definition are antennas that are mounted on the cable strand, not on the poles, and thus create no climbing impediment. As to SCADA antennas, the discrimination provision of the Telecommunications Act of 1996 provides that a state or local government “shall not unreasonably discriminate among providers of functionally equivalent services.” (47 U.S.C. § 332(c)(7)(B)(i)(I).) SCADA antennas are used to monitor and control the operation of the electric utilities’ own supply systems and thus are not functionally equivalent to wireless service antennas, which are used to provide voice and other telecommunication services to the wireless companies’ customers.<sup>9</sup> The evidence shows that wireless antennas are distinguishable from other Class C communications equipment in that they may present RF exposure levels that the FCC has found could be harmful to line crews. An exception for Class C antennas that have little or no RF exposure risk is not discrimination; it is a recognition of the different attributes of the antennas. The testimony of SCE’s witness confirms that there is no other objection to the exception provision in Proposal 1. We agree with proponents of Proposal 1 and with SCE’s expert that providing an exception for supply and strand-mounted antennas from the requirements of proposed Rule 94 is appropriate. The settlement agreement, discussed below, endorses this approach.

## **6. Jurisdictional Challenge**

The Wireless Group recognized and praised the Commission’s workshop approach to forging agreement on antenna rules. It noted the “significant degree

---

<sup>9</sup> See *Bay Area Cellular Telephone Company v. San Francisco* (N.D. Cal. 2005, 2005 U.S. Dist. LEXIS 31927 (“functional equivalence” relates to the telecommunications services that the actual competing entities provide)).

of overlap” between Proposal 1 and Proposal 2. Both proposals (1) define antennas similarly; (2) treat antennas as Class C equipment, thereby maintaining many working and climbing space requirements; (3) provide additional vertical clearances from other conductors and equipment; (4) maintain vertical clearances from the ground; and (5) include a “marking rule” that provides contact information for each antenna installation.

The Wireless Group argued, however, that this Commission was preempted from adopting two of the earlier provisions of Proposal 1: first, the rule requiring a sign that deals with an antenna’s RF exposure limits (Rule 94.6) and, second, the rule requiring a locally verifiable method of powering down or disconnecting wireless antennas (Rule 94.7). The wireless carriers point out that federal law preempts state law under the Supremacy Clause (U.S. Constitution, Art. VI, § 2) when the federal statute expresses a clear intent to preempt state law, when federal and state laws conflict, or when state law stands as an obstacle to a federal policy. (*See, e.g., Capital Cities Cable, Inc. v. Crisp* (1984) 467 U.S. 691.) Specifically, the Wireless Group states, Congress enacted 47 U.S.C. § 332(c)(7)(B)(iv) to provide that:

No state or local government or instrumentality thereof may regulate the placement, construction, and modification of personal wireless service facilities on the basis of the environmental effects of radio frequency emissions to the extent that such facilities comply with the [Federal Communication] Commission’s regulations concerning such emissions.

The Wireless Group cites cases upholding the FCC position that “a local government may not require a facility to comply with RF emissions or exposure limits that are stricter than those set forth in the Commission’s rules,” and that state and local governments are forbidden from “restrict[ing] how a facility

authorized by the Commission may operate based on RF emissions or any other cause.”<sup>10</sup>

The Wireless Group relies in particular on an FCC ruling in 2003 called the *Anne Arundel* opinion.<sup>11</sup> In *Anne Arundel*, a county enacted an ordinance requiring, among other things, that wireless operators demonstrate that their systems would not interfere with or degrade the county’s public safety radio system. One result of any such interference could be revocation of the carrier’s zoning permit. The county argued that it was not attempting to substitute its own technical standards or to regulate beyond the federal guidelines. The FCC rejected this argument and found preemption, stating:

[T]he fact remains that by asserting authority to prohibit operation that it determines causes public safety interference, the County is effectively regulating federally-licensed operation...Such regulation of operation is different in kind from traditional zoning regulation of the physical facility such as height limitations, setback requirements, screening or painting guidelines, structural safety standards, and the like. Therefore, we find that the County’s Ordinance regulates beyond traditional zoning functions and impermissibly extends into the regulation of [RF interference].<sup>12</sup>

---

<sup>10</sup> See *Cellular Phone Taskforce v. FCC* (2d Cir. 2000) 205 F.3d 82 (where the court found that FCC rules preempted state regulation of the operation of wireless facilities based on RF); *Cal RSA No. 4 v. Madera County* (E.D. Cal. 2003) 332 F.Supp. 2d 1291, 1302 (local governments’ decisions regarding construction of wireless facilities must not be based on environmental effects of RF if the facilities comply with the FCC regulations).

<sup>11</sup> *Petition of Cingular Wireless L.L.C. for a Declaratory Ruling that Provisions of the Anne Arundel County Zoning Ordinance Are Preempted as Impermissible Regulation of Radio Frequency Interference Reserved Exclusively to the Federal Communications Commission*, WT-Docket No. 02-100, Memorandum Opinion and Order, July 7, 2003.

<sup>12</sup> *Anne Arundel* at ¶ 19.

The Wireless Group argued that a requirement to post a sign stating the applicable MPE limit on wireless antennas where necessary and a requirement that a disconnect switch of some kind be installed nearby constitute the same type of interference with RF operations that was ruled improper in the *Anne Arundel* opinion.

Supporters of Proposal 1 argued that the Wireless Group takes the FCC exemption to an unreasonable extreme, suggesting that this Commission cannot even take note of the FCC rules on RF exposure in establishing wireless antenna construction rules on utility poles. They state:

The Commission cannot regulate in a vacuum. When considering a rule that will regulate the placement of wireless antennas on joint use poles, the Commission must consider the FCC regulations in regard to RF emissions and exposure levels; to not do so would be remiss. The federal law, 47 USC § 332(c)(7)(A) first reserves to states and local governments the right to regulate the placement, construction, and modification of personal wireless service facilities. The preemptive language that follows in Section 332(c)(7)(B) prohibits states and local governments from regulating these facilities based on the environmental effects of RF emissions to the extent such facilities comply with the FCC. Case law indicates that this is a narrow area of preemption that prohibits states or local governments from imposing more stringent RF emission standards. The statute certainly does not prohibit the Commission from considering the FCC's regulations when adopting a rule regulating the construction and placement of wireless antennas on joint use poles in the interests of worker safety.

Supporters of Proposal 1 cited the cases of *Sprint Spectrum L.P. v. Township of Warren Planning Board* (1999) 737 A.2d 715, and *MetroPCS, Inc. v. City & County of San Francisco* (2004) 400 F.3d 715, in support of the proposition that the federal preemption here is narrowly drawn.

In *Sprint Spectrum*, the antenna operator asserted that the local Board of Health was prohibited by federal law from review of the operator's compliance with RF emissions. The Board of Health maintained that it had the right to verify that the emissions complied with relevant federal standards. The New Jersey Superior Court dismissed the suit, finding that the intent of Congress in 47 USC § 332 was for a limited preemption and not an expansive one. It ruled:

The Board had made no effort to impose its own view of RF levels on the application nor to substitute its judgment for that of the FCC, but has merely sought a demonstration of compliance. Nothing in the statutory language is so broadly preemptive as to excuse the applicant from having to demonstrate compliance with FCC regulations regarding RF emissions. (325 N.J. Super 61, 74-75.)

In *Metro PCS*, the 9<sup>th</sup> Circuit Court of Appeals affirmed the ruling of the district court that the city's rejection of an application to place a wireless antenna on the roof of a parking garage was not improperly based on environmental concerns about RF emissions. Despite public protests about RF emissions, the Court of Appeals agreed that the denial itself was based on zoning standards unrelated to environmental concerns and RF emissions. Moreover, the Court found that substantial evidence supported the city's decision and that judicial review under this standard should be "deferential" to the decision-making government body. It added:

[T]his Court may not overturn the Board's decision on "substantial evidence" grounds if that decision is authorized by applicable local regulations and supported by a reasonable amount of evidence (*i.e.*, more than a "scintilla" but not necessarily a preponderance.) (400 F.3d at 725.)

Proposal 1 supporters argued that the FCC itself has acknowledged that state and local governments have a role to play in devising efficient procedures for ensuring that the antenna facilities located in their communities comply with

the FCC's limits for human exposure to RF electromagnetic fields. FCC guidelines comment that "state and local governments may wish to verify compliance with the FCC's exposure limits in order to protect their own citizens."<sup>13</sup> (See also, *National Assn of State Utility Consumer Advocates and National Association of Utility Commissioners v. FCC, et al.*, No. 05-11682, FCC No. 98-00170 (11<sup>th</sup> Cir., July 31, 2006) (FCC exceeded its authority in preempting state requirement for line item regulation in customer billings for cellular wireless services.)

### **6.1 Discussion**

Because of the settlement agreement, we need not rule on the jurisdictional issues raised by the Wireless Group. Nevertheless, the record shows that the FCC encourages both signage and power-down capability as means of protecting workers from impermissible RF exposure. The Wireless Group's FCC expert testified that these are reasonable safeguards for a unique and potentially dangerous workplace - the working space on a distribution pole. The danger inherent in this workplace is uncontested. As SDG&E lineman Gregory Walters testified,

[A] lineman's place of employment is unique - a distribution pole ranging in height from 30 to 150 feet. It is a unique and treacherous work environment heightened by the ultra-hazardous nature of working with high-voltage electric conductors. (Exhibit 4, at 7.)

---

<sup>13</sup> FCC Local and State Government Advisory Committee Publication, "A Local Government Official's Guide to Transmitting Antenna RF Emission Safety: Rules, procedures, and Practical Guidance," June 2000, at 1.

When asked what would happen if a worker without extensive electrical training climbed a distribution pole, Walters replied simply: "He would probably die." (Transcript, at 95.)

The testimony of the linemen was compelling. Line crews are required to climb utility poles on a daily basis, frequently to make emergency repairs. Often, a lineman must spend an hour or more working in a single location on the pole. If his work is near an antenna with RF emissions that exceed the FCC's maximum exposure limit, then the lineman must maintain a distance (as recommended by the FCC) from the antenna. The lineman cannot step away from the utility pole, since he is strapped to it. He cannot climb down the pole to maintain the FCC-recommended distance, since that would put him well below the area in which he must work. His only choice is to climb up the pole. That of course takes him closer to the high-voltage equipment installed in the upper portion of a utility pole.

Using a model of a typically configured utility pole, lineman Greg Walters demonstrated the contortions a lineman can go through in trying to maintain the FCC's recommended distance from an antenna below him and at the same time avoiding high-voltage equipment above him. During this time, the lineman is likely to be maneuvering a "hot stick" to apply a temporary ground on energized conductors.

The testimony suggests that emission levels of most wireless antennas are low enough so that working near the antenna requires no FCC-mandated precautions. But for antennas that *do* trigger the FCC precautions, the lineman on a utility pole has only two choices - stay the FCC-recommended distance away from the antenna or find a way that he can be certain will temporarily reduce power to the antenna. If the lineman must work within the RF approach

distance identified by the FCC, then powering down or disconnecting the antenna is the only precaution available to him.<sup>14</sup>

As discussed below, the settlement agreement provides protocols for de-energizing an RF antenna and requires their inclusion in contracts between signatory joint pole owners and antenna owners.

## **7. The Proposed Settlement**

The proposed settlement would retain all of the provisions of Proposal 1 except for Section 94.6 (Identifying Exposure) and Section 94.7 (Controlling Exposure). Essentially the same requirements of those two sections (additional signage on the utility pole for each RF antenna and a method for reducing or shutting off power to RF antennas) would be required in the contractual requirements between the utilities that operate jointly owned poles and the wireless carriers that seek to mount antennas on those poles.

The settlement agreement requires signatory antenna owners to provide signage on jointly owned utility poles regarding compliance with the FCC exposure limits for each antenna installation and specifying the minimum approach distance if necessary. It also requires protocols for de-energizing antennas with RF emissions that exceed the FCC's general population maximum permissible exposure limits. In the protocols for de-energizing antennas in non-emergency or routine situations, the antenna owner would be responsible for de-energizing an antenna upon request of the joint pole owners. In the protocols for

---

<sup>14</sup> All parties appeared to have agreed that three of the FCC's recommendations for controlling RF exposure - distancing, power cutoff, and warning signs - can be applicable to a utility pole; two of the FCC's recommendations - fencing/shielding and protective clothing - are not practical as to utility poles or to those who must climb the poles. (See FCC OET Bulletin 65.)



de-energizing antennas in emergency situations, utility line crews would be authorized to de-energize the antenna if the antenna owner cannot be reached in time to deal with the emergency.

At the settlement hearing, in response to questions by the ALJ and by the Assigned Commissioner, representatives of two union parties – the IBEW and the Communication Workers – stated that in their judgment the settlement provisions regarding additional signage and de-energizing antennas will provide the same level of protection for the line crews covered by the agreement as would Sections 94.6 and 94.7 of the original Proposal 1. The advantage of the settlement, they said, was that these provisions could be put into place soon without the likelihood of jurisdictional challenge over state enforcement of these requirements.

The Commission's CPSD, which was a principal author of the original Proposal 1, stated that it supported the proposed settlement for much the same reasons as the unions, emphasizing the importance of putting procedures in place to better protect line crews.

Questioned about settlement language on enforceability of the settlement terms, counsel for the Wireless Group stated that any signatory party alleging breach of the settlement agreement can seek redress both in civil courts and before this Commission, and that nothing in the agreement is intended to restrict the jurisdiction of the Commission. We understand that to mean that, pursuant to Pub. Util. Code § 451, the Commission would be free in an action alleging breach of the settlement terms or protocols to consider appropriate action on any safety concerns raised by the dispute.

The settlement agreement deals only with joint use distribution poles owned by the settling parties. Poles owned exclusively by PG&E and SCE would

be covered by licensing agreements that, according to those utilities, incorporate signage and de-energizing requirements along with the other requirements of new Rule 94. SDG&E, which is not a signatory to the settlement agreement, explained that it has no jointly owned distribution poles and that RF antennas on its solely owned poles are governed by a licensing agreement that imposes even more rigid restrictions than those adopted in this proceeding. The SDG&E license agreement requires a power shut-off device on site accessible to SDG&E line crews, and line crews are directed to work no less than 3 feet away from any RF-emitting antenna. Counsel for SDG&E stated that the utility prefers to continue its licensing restrictions but it nevertheless supports the settlement agreement in this proceeding.

## **8. Conclusion**

Since the settlement agreement appears to provide as much if not more safeguards for most line crews working on distribution poles, and since the settlement has no opposition by any party to this proceeding, we conclude that it should be approved. We have reviewed the agreement pursuant to the Commission's settlement rules and we find that the settlement is reasonable in light of the whole record, consistent with law, and in the public interest. (Rule 12.1(d) of the Rules of Practice and Procedure.) The settlement agreement is attached to this decision as Appendix 2.

Parties at the settlement hearing stated that they believed that virtually all wireless carriers that install antennas now operating in California are signatories to and bound by the additional signage and de-energizing requirements of the settlement agreement with PG&E and SCE (or by the substantially similar requirements of the SDG&E licenses). Nevertheless we are concerned that new wireless carriers may enter this fast-growing market in this state. We are also

concerned about the safety of the line crews employed by the small rural utilities who are not signatories to the settlement. Accordingly, our ordering paragraphs today impose reporting requirements on wireless carriers intended to permit CPSD to monitor RF antenna installations and to make recommendations to the Commission as necessary to ensure that appropriate signage and de-energizing procedures are in place.

Our order today also authorizes the addition of the amended new Rule 94 to GO 95 (deleting Rules 94.6 and 94.7) to set forth minimum construction requirements for attaching wireless antennas to jointly owned utility poles. Rule 94 is set forth in its entirety and attached to this decision as Appendix 1. We note that these rules clearly define antennas; treat antennas as Class C equipment, thereby maintaining many working and climbing space requirements; provide additional vertical clearances from other conductors and equipment; maintain vertical clearances from the ground; and include a "marking rule" that provides contact information for each antenna installation. These are essential minimum requirements on which the utilities, unions, Commission staff and wireless operators now agree.

In its utility ROW decision in D.98-10-058, the Commission concluded that there was a need for safety requirements for wireless attachments to utility poles, and it instructed incumbent utilities to establish standards. The incumbent utilities have chosen this proceeding in which to establish minimum construction standards for wireless antenna attachments. CPSD, which helped develop new Rule 94, states that the drafters were careful not to intrude on RF clearance standards established by the FCC. Instead, RF clearance standards were in all cases retained, but additional safeguards were imposed where necessary to permit utility employees and other authorized persons to climb the poles and

work on particular attachments and still be protected by the FCC-mandated clearances from RF exposure.

### **9. Implementation of Rule Changes**

The adoption of the rule at issue in this proceeding will require utilities to change their company standards, communicate the changes to field personnel, and conduct varying degrees of training prior to full implementation of the rule. The rule is not retroactive and does not affect wireless antennas already installed on utility poles through private agreements between antenna owners and joint pole operators. The effective date for implementation of Rule 94 shall be no later than 180 days after issuance of the final decision in this proceeding. Our order today so provides.

### **10. Annual Reporting Requirement**

We recognize that the private agreements requiring additional FCC information and de-energizing protocols will not apply to all public utilities with jointly owned poles upon which wireless carrier RF antennas may be installed, such as small electric utilities like Mountain Utilities, Inc., Bear Valley Electric Service, Sierra Pacific Power Company, and Pacific Power and Light Company. Similarly, a wireless carrier that is not a signatory to the settlement agreement would not be bound by terms of the settlement, and even a signatory utility would not be required by the settlement to replicate its terms with a non-party seeking to install an antenna.

While the great majority of line crews are protected by the new Rule 94 and the settlement agreement set forth in this decision (or, in the case of SDG&E, by equivalent or greater requirements), we want to be prepared to act further, if necessary, to ensure the safety of all line crews required to work on jointly owned poles subject to our jurisdiction.

Accordingly, as part of this GO 95 rulemaking proceeding, and in response to comments by the parties, our order today directs all wireless carriers subject to Commission safety jurisdiction to submit an annual written report to CPSD in a format to be prescribed by CPSD, beginning January 1, 2008.<sup>15</sup> Each such annual report shall set forth the following information:

1. Location of RF antennas installed / removed / reconstructed on jointly used transmission poles in California in the last 12 months.
2. Date of installation / removal / reconstruction of each such RF antenna described above.
3. The entity with which the antenna owner has leased or purchased the joint pole space for the RF antenna described above.

This information will enable CPSD to create an effective GO 95 audit program for RF-emitting devices located on jointly used transmission poles. Additionally, by knowing the entity from which pole space has been purchased or leased, CPSD will be able to determine that the provisions of the contract or

---

<sup>15</sup> The Proposed Decision distributed October 10, 2006, initially imposed this reporting requirement on all public utilities subject to Commission jurisdiction that have poles upon which wireless carrier RF antennas are mounted. In joint opening comments, PG&E and SCE objected to the requirement, stating that antenna installations generally are handled by joint pole associations rather than directly by the utilities, and that "the best sources for the requested information are the companies actually installing the RF antennas - *i.e.*, the wireless carriers." (Joint Comments, at 3.) In reply comments, PG&E and SCE changed their position, concluding that annual reporting requirements are unnecessary in this decision. Wireless carriers also commented on the annual reporting requirement, arguing that such a requirement was outside the scope of this proceeding. Upon due consideration, we conclude that the annual reporting requirement is necessary and is most effective and least burdensome when imposed upon the wireless carriers. As discussed in Section 10, we believe that such a requirement is within the scope of this rulemaking proceeding, and that parties have had ample opportunity to comment upon this requirement.

lease agreement meet or exceed the requirements of the settlement agreement. With this information in hand, CPSD shall make recommendations to the Commission on any action CPSD deems necessary to ensure that the additional FCC information and de-energizing protocols are available for all line crews in their work on distribution poles subject to our jurisdiction.

We take official notice that the FCC requires RF antenna owners to file more extensive information (including the information required here) for each of its antenna installations, using FCC Form 854. (*See* 47 C.F.R. Chapter 1, Part 17.) Since the information required by this Commission already exists and is in the possession of wireless carriers pursuant to the FCC requirement, the burden of preparing this annual PUC report should be minimal.

#### **11. Comments on Proposed Decision**

The Proposed Decision of the ALJ in this matter was mailed to the parties in accordance with Pub. Util. Code § 311 and Rule 14.2(a) of the Rules of Practice and Procedure. Comments were filed on October 30, 2006, and reply comments were filed on November 6, 2006.

In response to the comments, we have revised the annual reporting requirement to apply to wireless carriers subject to our safety jurisdiction rather than to electric utilities. This is because the wireless carriers have more accurate information on their RF antenna installations and they already possess and routinely furnish such information to the FCC. (*See* FCC Form 854.)

The wireless carriers urge that the Commission limit the Proposed Decision to assessing only the reasonableness of the settlement proposal under Commission Rule 12.1(d) (“the settlement is reasonable in light of the whole record, consistent with law, and in the public interest”). The flaw in that position is that this is a rulemaking proceeding dealing with important

worker safety rules, not an application for particular ratemaking or service authority with limited disputes that the parties propose to settle.

In this rulemaking proceeding, the Commission has been asked by the parties to enact a new rule as part of GO 95 to enhance the safety of the public and – in particular – utility line crews on a statewide basis. The parties proposed three alternative versions of the new rule, and the Proposed Decision properly explains why it favored a rule (Proposal 1) that required, among other things, signage notifying line crews of the FAA warnings applicable to each installed RF antenna and a procedure for reducing power on certain high-intensity RF antennas so that emergency work could be safely performed.

Wireless carriers opposed inclusion of those two elements of the proposed new Rule 94, urging instead that those provisions be removed from Rule 94 and included instead in private agreements between antenna owners and joint pole owners.

For the reasons discussed, the Proposed Decision approves the settlement agreement. Nevertheless, as acknowledged by all of the parties, the additional signage and power-down provisions under the settlement would not apply to small electric utilities (*e.g.*, Mountain Utilities, Inc., Bear Valley Electric Service, Sierra Pacific Power Company, and Pacific Power and Light Company) or to wireless carriers and others not signatories to the settlement agreement. Line crews climbing jointly owned poles on behalf of those entities not bound by the settlement would do so without required rules that warn them of FCC restrictions on RF antennas or that provide a power-down procedure on high-intensity antennas in cases of emergency.

Recognizing this gap in worker safety protection, the Proposed Decision imposed an annual reporting requirement that would alert the Commission to

any RF antenna installation that did not provide the full range of worker safety provisions envisioned by the original Proposal 1 or by the amended Proposal 1 as augmented by the settlement agreement. More importantly, the reporting requirement would encourage wireless carriers and joint pole owners to include these important safety features for RF antennas even in those limited instances where the settlement requirements did not apply. After years of discussing the critical safety risks of climbing obstacles on distribution poles, the parties knew or should have known that the Proposed Decision would seek to address this gap in worker safety coverage, and parties have had ample opportunity in their comments to address a reporting requirement. In view of the worker safety implications, it is surprising and disappointing that so minimal a reporting requirement (the FCC estimates it will take 10 minutes to comply with its similar reporting requirement) is resisted by any party.

We have carefully considered the parties' other comments and reply comments, and we have made minor changes to the Proposed Decision where warranted.

## **12. Assignment of Proceeding**

Geoffrey F. Brown is the Assigned Commissioner and Glen Walker is the assigned ALJ in this proceeding.

### **Findings of Fact**

1. GO 95 governs the construction of overhead electrical supply and communications systems.
2. The Commission on February 24, 2005, issued this Order Instituting Rulemaking to consider a GO 95 rule for attaching wireless antennas to jointly used utility poles and towers.



3. Commission staff, industry representatives, labor representatives and the public conducted seven days of public workshops to develop a proposed new Rule 94 dealing with wireless antennas.

4. On September 12, 2005, the parties submitted a joint workshop report that included three alternative proposals for a new Rule 94.

5. Rule 94 would add minimum construction requirements for attaching wireless antennas to poles.

6. Proposal 1 for Rule 94 was sponsored by CPSD, IBEW, the Communication Workers, PG&E and SDG&E.

7. Proposal 2 for Rule 94 was sponsored by SCE and is supported by the Wireless Group and intervenor William Adams.

8. Proposal 3 for Rule 94 has been withdrawn.

9. A motion to set aside submission of the Proposed Decision in this matter was granted on July 20, 2006, so that parties could consider a settlement proposal.

10. An unopposed settlement agreement by the parties was presented to the Commission on August 23, 2006.

11. The settlement agreement removes Rule 94.6 and 94.7 from Rule 94 for which the now withdrawn proposed decision formed an evidentiary basis but incorporates essentially those same provisions in private agreements between signatory utilities and antenna owners.

12. The settlement agreement is supported by PG&E, SCE, the union parties, CPSD and the Wireless Group.

13. Public safety requires the provisions of Rule 94, as amended by the settlement agreement, be promulgated.

### **Conclusions of Law**

1. The Commission has comprehensive jurisdiction over questions of public health and safety arising from utility operations. Pub. Util. Code § 761, *inter alia*, instructs this Commission to promulgate rules for utilities when safety so requires.

2. GO 95 rules concern the safety of the general public, utilities' customers and utilities' employees.

3. Rule 94 as set forth in Appendix 1 of this decision should be approved and adopted because public and worker safety so requires.

4. The settlement agreement set forth in Appendix 2 of this decision should be approved as in the public interest for those utility workers covered thereby.

5. Rule 94 should become effective prospectively 180 days after issuance of the final decision in this proceeding.

6. Wireless carriers subject to Commission safety jurisdiction should be directed to file an annual written report to CPSD in a format to be prescribed by CPSD, beginning January 1, 2008, identifying for the last 12 months the location and date of installation or removal of RF antennas installed on joint use distribution poles and the entity from which the antenna owner has leased or purchased joint pole space.

**ORDER**

**IT IS ORDERED** that:

1. General Order (GO) 95 is amended to incorporate Rule 94 and the amendment to Rule 20.0, as set forth in Appendix 1 attached hereto and made part hereof.

2. The revisions to GO 95 authorized today will become effective prospectively 180 days after the date of today's decision.

3. The settlement agreement attached hereto as Appendix 2 is approved as in the public interest.

4. All wireless carriers subject to Commission safety jurisdiction are directed to submit an annual written report to the Commission's Consumer Protection and Safety Division (CPSD), in a form to be prescribed by CPSD, beginning January 1, 2008. Each such annual report shall set forth the following information:

- \* Location of RF antennas installed / removed / reconstructed on jointly used transmission poles in California in the last 12 months.
- \* Date of installation / removal / reconstruction of each such RF antenna described above.
- \* The entity with which the antenna owner has leased or purchased the joint pole space for the RF antenna described above.

5. CPSD is directed to review the annual reports described in Ordering Paragraph 4 and report to the Commission, with recommendations, on any wireless carrier RF antenna installations that have taken place since the effective date of this decision that do not contain additional FCC information and de-energizing protocols at least as substantial as those set forth in Appendix 2 of this decision.

6. Rulemaking 05-02-023 is closed.

This order is effective today.

Dated \_\_\_\_\_, at San Francisco, California.

**APPENDIX 1****New GO 95, Rule 20 (Definition)**

**20.0 Antenna** means a device for emitting and/or receiving radio frequency signals.

**New GO 95, Rule 94 – Antennas**

94 Antennas

**94.1 Definition** (See Rule 20.0)

**94.2 Maintenance and Inspection** (See Rules 31.1 and 31.2)

**94.3 General Requirements**

On joint use poles supporting Class T, C, L or H Circuits (up to 50 kV), the following shall apply:

- A.** Antennas shall meet the requirements of Class C equipment, unless otherwise specified in this rule.
- B.** All associated elements of the antenna (e.g. associated cables, messengers, and pole line hardware) shall meet the requirements of Class C circuits.

**94.4 Clearances**

- A.** Antennas and supporting elements (e.g. crossarms, brackets) shall maintain a vertical clearance of 6 feet from Supply Conductors operating at 0 – 50kV. (See Figure 94-1)
- B.** Antennas and supporting elements (e.g. crossarms, brackets) shall maintain a 2 ft. vertical separation from communication conductors and equipment. (See Figure 94-2)
- C.** Antennas shall maintain a 2 ft. horizontal clearance from centerline of pole. (See Figures 94-1 and 94-2)
- D.** Antennas shall have a vertical clearance above ground as specified in Table 1, Column B, Cases 1 to 6a.

### **94.5 Marking**

- A.** Joint use poles shall be marked with a sign for each antenna installation as follows:
- (1)** Identification of the antenna operator
  - (2)** A 24-hour contact number of antenna operator for Emergency or Information
  - (3)** Unique identifier of the antenna installation.

#### **Exceptions:**

Antennas utilized by utilities for the sole purpose of operating and monitoring their supply system are exempt from this rule and shall only meet the construction and clearance requirements of supply equipment.

Antennas embedded in or attached to communication cables and messengers are exempt from this rule and shall only meet the construction requirements for Class C circuits.

Rules 94.4-A & C

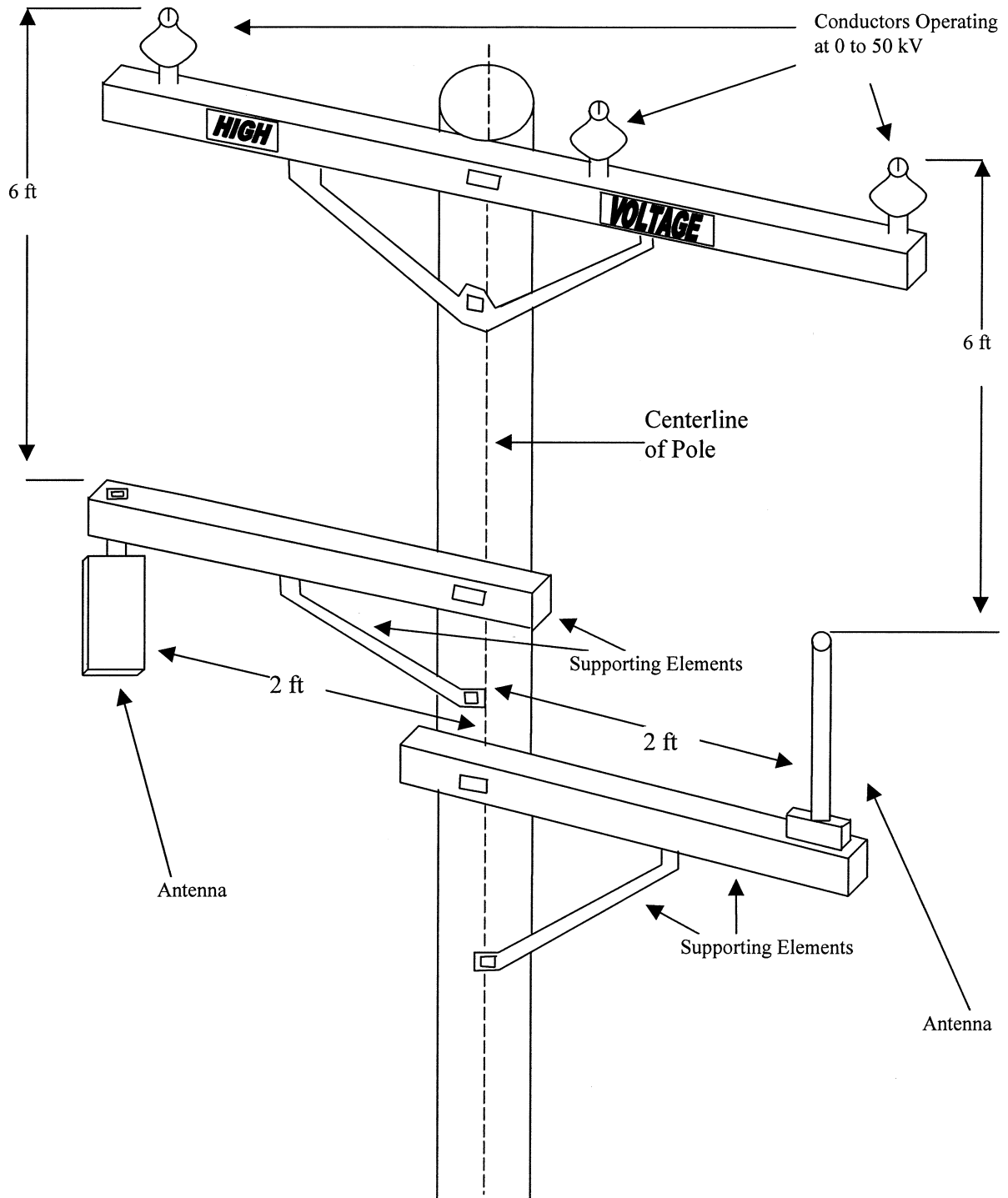

Figure 94-1

Rules 94.4 B & C

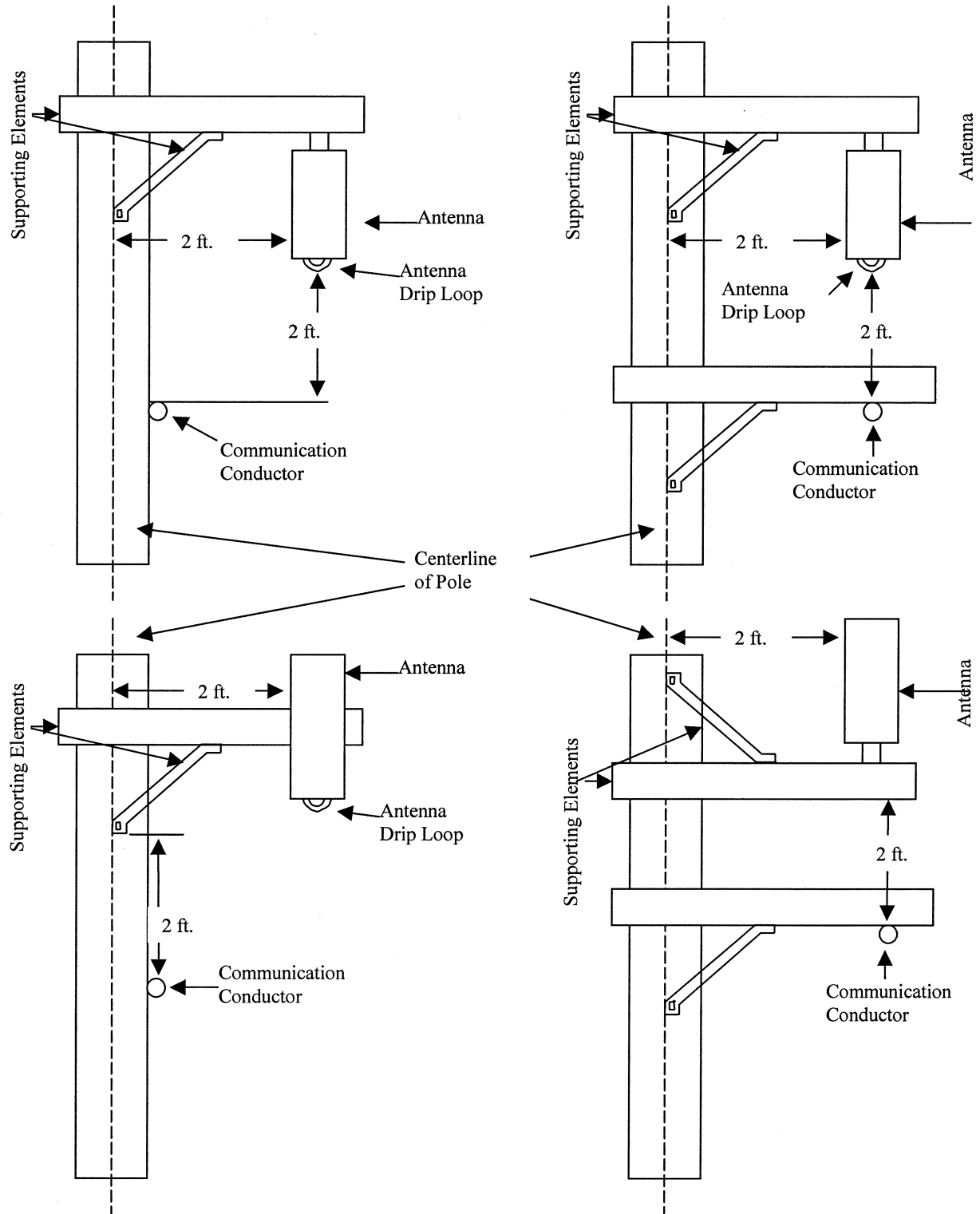

Figure 94-2  
(END OF APPENDIX 1)



**APPENDIX 2**

**SETTLEMENT AGREEMENT AMONG AT&T CALIFORNIA, CALIFORNIA CABLE & TELECOMMUNICATIONS ASSOCIATION, CLEARLIX NETWORK CORPORATION, COMMUNICATIONS WORKERS OF AMERICA DISTRICT 9, CONSUMER PROTECTION AND SAFETY DIVISION, CROWN CASTLE USA INC., INTERNATIONAL BROTHERHOOD OF ELECTRICAL WORKERS LOCAL 1245, NEW CINGULAR WIRELESS PCS, LLC, NEXTG NETWORKS OF CALIFORNIA INC., OMNIPOINT COMMUNICATIONS, INC., dba T-MOBILE, PACIFIC GAS AND ELECTRIC COMPANY, SOUTHERN CALIFORNIA EDISON COMPANY, SPRINT NEXTEL, VERIZON CALIFORNIA INC., VERIZON WIRELESS AND WILLIAM ADAMS**

In accordance with Rule 51.1 of the California Public Utilities Commission's (Commission) Rules of Practice and Procedure, AT&T California, California Cable & Telecommunications Association, Clearlix Network Corporation, Communications Workers of America District 9, Consumer Protection and Safety Division, Crown Castle USA, Inc., International Brotherhood of Electrical Workers Local 1245, New Cingular Wireless PCS, LLC, NextG Networks of California Inc., Omnipoint Communications, Inc., dba T-Mobile, Pacific Gas and Electric Company, Southern California Edison Company, Sprint Nextel, Verizon California Inc., Verizon Wireless and William Adams (collectively, the "Settling Parties") hereby enter into this Settlement Agreement (Agreement) to resolve all issues among the Settling Parties in Rulemaking (R.) 05-02-023, Order Investigation Rulemaking to consider uniform rules for attaching wireless antennas to jointly used poles.

**RECITALS**

1. On February 24, 2005, the Commission issued an Order Instituting Rulemaking in R.05-02-023 to consider a new rule to GO 95 to establish uniform construction standards for attaching wireless antennas to jointly used utility poles.

2. Evidentiary hearings were conducted in the proceeding on February 7-9, 2006, during which the Commission heard testimony from nine witnesses and received 22 exhibits into evidence.

3. Opening and reply briefs were filed on March 13 and 28, 2006, respectively, at which time the matter was submitted for Commission decision.

4. On April 25, 2006, the Assigned Administrative Law Judge, ALJ Walker, issued his Proposed Decision ("the PD"). Opening and Reply Comments on the PD were filed on May 15 and 22, 2006, respectively. ALJ Walker has issued two revised versions of his Proposed Decision, which adopted Proposal 1 in its entirety, including the provisions of Rule 94.6 and 94.7.

5. On July 18, 2006, several parties in the proceeding submitted a joint petition to set aside submission of the proceeding pursuant to Rule 84 of the Commission's Rules of Practice and Procedure. The petition requested the Commission set aside the submission of the proceeding temporarily to allow the parties to pursue settlement discussions. On July 20, 2006, Assigned Commissioner Geoffrey F. Brown and Administrative Law Judge Michelle Cooke ruled that the parties shall submit any settlement on or before August 10, 2006.

6. Pursuant to Rule 51.1(b) of the Commission's Rules of Practice and Procedure, on July 28, 2006, the Settling Parties served notice of a settlement conference to be held telephonically on August 4, 2006.

7. On August 4, 2006, the settlement conference was held as scheduled. Following the settlement conference, the Settling Parties continued settlement discussions, resulting in this Agreement.

### SETTLEMENT AGREEMENT

In order to resolve disputed issues of fact and law and settle on a mutually acceptable outcome to the proceeding with due regard for public and worker safety concerns, and subject to the Recitals and reservations set forth in this Agreement, the Settling Parties hereby agree that this Agreement resolves all disputed issues relating to Rule 94.6 and Rule 94.7 raised in this proceeding.

The Agreement is presented to the Commission pursuant to Rule 51 of the Commission's Rules of Practice and Procedure.

The Settling Parties agree that, in the event any party, as a joint owner, lessee or licensee ("Antenna Owner/Operator") seeks to install or causes the installation of an Antenna (as defined in General Order (GO) 95 Rule 20.0) on a joint use utility pole, it is agreed that:

**1. Markings Related to the FCC's MPE Limits.**

The Antenna Owner/Operator shall provide, and update as necessary, accurate information regarding compliance with the Federal Communications Commission's Maximum Permissible Exposure (MPE) limits as set forth in Title 47 of the Code of Federal Regulations (CFR) for each particular Antenna installation. The Antenna Owner/Operator shall communicate such information through the use of a pole mounted marking as described in Exhibit A

(Additional Marking Requirements) and in writing to the other utilities and/or companies with facilities affixed to the pole in accordance with Paragraph 4 of this Agreement.

**2. Means of De-energizing Antennas.**

The Antenna Owner/Operator shall not install an Antenna on a joint use pole that emits RF energy in excess of the FCC's General Population/Uncontrolled maximum permissible exposure limits as set forth in 47 C.F.R. or effect a change to an existing Antenna site that will cause that Antenna to emit RF energy in excess of the FCC's General Population/Uncontrolled maximum permissible exposure limits as set forth in 47 C.F.R. except by providing to any other utility or company with facilities attached to the affected pole, a locally verifiable means to de-energize said Antenna. The protocols set forth in Exhibit B shall apply to non-emergency or routine working conditions. The protocols set forth in Exhibit C shall apply to emergency working conditions.

**3. Exemption.**

The provisions of this Agreement shall not apply to Antennas that are exempt from the provisions of General Order 95, Rule 94.

**4. Adoption of Operating Procedures.**

The Settling Parties further agree to memorialize the agreements set forth in Section 1 and 2 of this Agreement (including the procedures and protocols to be adopted thereunder) in separate, private agreements with affected utilities, companies or municipalities or in the Northern California Joint Pole Association's Operating Routine. Such agreements and procedures shall be adopted in a timely manner and Settling Parties agree to execute any and all

supplementary documents and take all actions which may be necessary or appropriate to give full force and effect to the terms and intent of this Agreement.

**5. Commission Approval of Settlement and Modification of Rule 94.**

The Settling Parties shall jointly request Commission approval of this Agreement and that the Commission adopt Rule 94, as that rule is set forth in Exhibit 1 of the Proposed Decision of ALJ Walker (mailed April 25, 2006), with the exception of provisions 94.6 and 94.7, which the parties stipulate should be removed from the rule. The Settling Parties additionally agree to actively support prompt approval of the Agreement and adoption of the modified Rule 94. Active support may include briefing, comments on the proposed decision, written and oral testimony, if testimony is required, appearance at hearings, and other means as needed to obtain the approvals sought. The Settling Parties further agree to participate jointly in briefings to Commissioners and their advisors, either in-person or by telephone, as needed regarding the Agreement and the issues compromised and resolved by it.

6. This Agreement is contingent upon (1) the Commission approving the terms and conditions herein as reasonable, and adopting it unconditionally and without modification, and (2) the Commission adopting the modified Rule 94 as provided in Paragraph 5, above. Upon satisfaction of these contingencies, the Settling Parties agree to waive any and all rights to challenge and/or appeal in any state or federal forum the Commission's decision in this proceeding.

7. The Settling Parties agree to negotiate in good faith to resolve any dispute arising out of the implementation, interpretation or alleged breach of this Agreement. In the event such negotiations are unsuccessful, the Settling Parties may seek appropriate relief from the

Commission. Such proceeding before the Commission will be limited to determining whether there has been a breach of this Agreement and ordering appropriate relief. In the event any of the Settling Parties do not reach agreement on the protocols described in this Agreement, the Commission may mediate a resolution between those Settling Parties. Nothing herein is intended to expand or restrict the jurisdiction of the Commission and the Settling Parties retain all of their rights with respect thereto.

8. The Settling Parties agree that this Agreement represents a compromise of positions, without agreement or endorsement of disputed facts and law presented by the Settling Parties in the proceeding.

9. This Agreement and the covenants and agreements contained herein shall be binding on, and inure to the benefit of, the parties hereto and their respective heirs, successors and assigns. The Settling Parties further agree and acknowledge that this Agreement and the covenants and agreements contained herein shall remain binding on the Settling Parties, notwithstanding the expiration of the term of any contract, lease or license relating to the use of a joint use pole.

10. This Agreement embodies the entire understanding and agreement of the Settling Parties with respect to the matters described herein, and, except as described herein, supersedes and cancels any and all prior oral or written agreements, principles, negotiations, statements, representations or understandings among the Settling Parties relating to the use of joint use poles.

11. The Settling Parties have bargained earnestly and in good faith to achieve this Agreement. The Settling Parties intend the Agreement to be interpreted and treated as a unified, interrelated agreement.

12. Each of the Settling Parties hereto and their respective counsel and advocates have contributed to the preparation of this Agreement. Accordingly, the Settling Parties agree that no provision of this Agreement shall be construed against any Party because that Party or its counsel or advocate drafted the provision.

13. Each of the Settling Parties represents that it is duly authorized to enter into this Agreement, and each person signing on behalf of an entity represents that he or she is duly authorized to sign on behalf of that entity.

14. This document may be executed in counterparts, each of which shall be deemed an original, but all of which together shall constitute one and the same instrument.

15. This Agreement shall become effective among the Settling Parties on the date the last Party executes the Agreement as indicated below.

16. In witness whereof, intending to be legally bound, the Settling Parties hereto have duly executed this Agreement on behalf of the Settling Parties they represent:

AT&T California

By: \_\_\_\_\_  
Its: \_\_\_\_\_

California Cable & Telecommunications Association

By: \_\_\_\_\_  
Its: \_\_\_\_\_

Clearlinx Network Corporation

By: \_\_\_\_\_  
Its: \_\_\_\_\_

Communications Workers of America District 9

By: \_\_\_\_\_  
Its: \_\_\_\_\_

Consumer Protection and Safety Division

By: \_\_\_\_\_  
Its: \_\_\_\_\_

Crown Castle USA Inc.

By: \_\_\_\_\_  
Its: \_\_\_\_\_

International Brotherhood of Electrical Workers Local 1245

By: \_\_\_\_\_  
Its: \_\_\_\_\_

New Cingular Wireless PCS, LLC

By: \_\_\_\_\_  
Its: \_\_\_\_\_



NextG Networks of California, Inc.

By: \_\_\_\_\_  
Its: \_\_\_\_\_

Omnipoint Communications, Inc., dba T-Mobile

By: \_\_\_\_\_  
Its: \_\_\_\_\_

Pacific Gas and Electric Company

By: \_\_\_\_\_  
Its: \_\_\_\_\_

Southern California Edison Company

By: \_\_\_\_\_  
Its: \_\_\_\_\_

Sprint Nextel

By: \_\_\_\_\_  
Its: \_\_\_\_\_

Verizon California Inc.

By: \_\_\_\_\_  
Its: \_\_\_\_\_

Verizon Wireless

By: \_\_\_\_\_  
Its: \_\_\_\_\_

William Adams

By: \_\_\_\_\_

**EXHIBIT A****ADDITIONAL MARKING REQUIREMENTS**

Antenna Owner/Operators are responsible for the installation and upkeep of their sign or signs at each joint use site.

- a. In addition to the requirements of GO 95, Rule 94.5 (Marking), at a minimum, each Antenna Owner/Operator will also affix a sign that:
  - (i) identifies the applicable FCC exposure category (General Population/Uncontrolled or Occupational/Controlled);
  - (ii) identifies the FCC's recommended minimum approach distance as set forth in 47 C.F.R.; and
  - (iii) is of weather and corrosion resistant material.
  
- b. The Antenna Owner/Operator will place the sign so that it is clearly visible to workers who otherwise climb the pole or ascend by mechanical means and affix said sign:
  - (i) no less than three (3) feet below the Antenna (measured from the top of the sign); and
  - (ii) no less than nine (9) feet above the ground line (measured from the bottom of the sign).
  
- c. The Antenna Owner/Operator may install a single sign that contains the information required by GO 95, Rule 94 and section (a) above, or separate signs. In the event one or more Antennas are affixed to a pole, each Antenna Owner/Operator shall provide a sign with sufficient information to allow workers to identify its Antennas.

**EXHIBIT B****PROTOCOL FOR DE-ENERGIZING ANTENNAS IN NON-EMERGENCY OR ROUTINE WORKING CONDITIONS**

In the event an Antenna subject to Section 2 needs to be de-energized to perform non-emergency work, e.g., routine maintenance and/or repairs, on a joint use distribution pole, the following shall apply:

- a. The utility or company shall contact the Antenna Owner/Operator (in the case of a wireless carrier they shall contact the carrier's Network Operations Center) with a minimum of twenty-four (24) hours advance notice. The following information shall be provided:
  - i) identity of the utility/company representative and call back number
  - ii) the unique identifier of the Antenna
  - iii) the site address and/or location, if available
- b. The Antenna Owner/Operator shall de-energize the Antenna at the requested time or at a time otherwise mutually agreed upon with the utility.
- c. The procedures for de-energizing the subject Antenna shall provide the requesting utility or company with a satisfactory on-site means to verify the Antenna is de-energized.
- d. Upon completion of the work on the site, the utility or company shall contact the Antenna Owner/Operator (in the case of a wireless carrier, its Network Operations Center shall be contacted) to inform them that the Antenna may be re-energized.
- e. The Antenna shall not be re-energized by the Antenna Owner/Operator without confirmation from the utility or company.
- f. The requesting utility or company will only re-energize the Antenna with the Antenna Owner/Operator's prior written consent.

**EXHIBIT C****PROTOCOL FOR DE-ENERGIZING ANTENNAS IN EMERGENCY WORKING CONDITIONS**

In the event an Antenna subject to Section 2 needs to be de-energized in emergency working conditions, i.e., in a situation where there is an imminent or actual danger to public or worker safety necessitating immediate and non-routine work on the pole, for example in direct response to a fire, explosion, lightning, storm, earthquake, vehicular accident, terrorism, or some other unanticipated and catastrophic event, the following shall apply:

- a. The utility or company shall make a good faith effort to contact the Antenna Owner/Operator (in the case of a wireless carrier they shall contact the carrier's Network Operations Center). The following information shall be provided:
  - i) identity of the utility/company representative and call back number
  - ii) the unique identifier of the Antenna
  - iii) the site address and/or location, if available
  - iv) state nature of the emergency and/or site condition.
- b. The Antenna Owner/Operator shall de-energize the Antenna upon request in emergency working conditions.
- c. If the requesting utility or company is unable to contact the Antenna Owner/Operator, the requesting utility or company shall de-energize the subject antenna pursuant to mutually agreed upon procedures for that particular type of equipment or by using any necessary means available. The procedures for de-energizing the subject Antenna referred to above shall provide the requesting utility or company with a satisfactory on-site means to de-energize the Antenna that is verifiable.
- d. Upon the completion of any necessary work to address the emergency, the utility or company shall notify the Antenna Owner/Operator (in the case of a wireless carrier, its Network Operations Center shall be contacted) that all work has been completed so that the Antenna Owner/Operator can take any necessary actions to re-energize the site.
- e. The Antenna shall not be re-energized by the Antenna Owner/Operator without confirmation from the utility or company.
- f. The requesting utility or company will only re-energize the Antenna with the Antenna Owner/Operator's prior written consent.

**(END OF APPENDIX 2)**

APPENDIX A

\*\*\*\*\* APPEARANCES \*\*\*\*\*

William P. Adams  
ADAMS ELECTRICAL SAFETY CONSULTING  
716 BRETT AVENUE  
ROHNERT PARK CA 94928-4012  
(707) 795-7549  
For: Self

Bruce Mclaughlin  
BRAUN & BLAISING, P.C.  
915 L STREET, SUITE 1420  
SACRAMENTO CA 95814  
(916) 326-5812  
mclaughlin@braunlegal.com  
For: California Municipal Utilities Association (CMUA)

Maria L. Bondonno  
Legal Division  
RM. 4008  
505 VAN NESS AVE  
San Francisco CA 94102  
(415) 355-5594  
bon@cpuc.ca.gov

Maria Politzer  
CALIFORNIA CABLE & TELECOM ASSOCIATION  
360 22ND STREET, NO. 750  
OAKLAND CA 94612  
(510) 628-8043 126  
mp@calcable.org  
For: CCTA

Jerome F. Candelaria  
CALIFORNIA CABLE TELEVISION ASSOCIATION  
360 22ND STREET, NO. 750  
OAKLAND CA 94612  
(510) 628-8043  
jfc@calcable.org  
For: California Cable Television Association

John C. Dodge  
Attorney At Law  
COLE, RAYWID & BRAVERMAN, LLP  
1919 PENNSYLVANIA AVE., N.W., STE 200  
WASHINGTON DC 20006  
(202) 828-9805  
jdodge@crblaw.com  
For: Crown Castle

Robert L. Ritter  
Attorney  
CROWN CASTLE INTERNATIONAL  
2000 CORPORATE DRIVE  
CANONSBURG PA 15317  
(724) 416-2417  
bob.ritter@crowncastle.com  
For: Crown Castle

James W. Mc Tarnaghan  
Attorney At Law  
DUANE MORRIS LLP  
ONE MARKET, SPEAR TOWER 2000  
SAN FRANCISCO CA 94105-1104  
(415) 957-3088  
jwmctarnaghan@duanemorris.com  
For: Verizon Wireless

Landis Martilla  
IBEW LOCAL 1245  
30 ORANGE TREE CIRCLE  
VACAVILLE CA 95687  
(415) 469-9903  
lkm4@ibew1245.com

Earl Nicholas Selby  
Attorney At Law  
LAW OFFICES OF EARL NICHOLAS SELBY  
418 FLORENCE STREET  
PALO ALTO CA 94301  
(650) 323-0990  
ens@loens.com  
For: Nextel of California, Inc./Sprint Nextel Corporation

Shanise Black  
Deputy City Attorney  
LOS ANGELES DEPARTMENT OF WATER & POWERA  
111 NORTH HOPE STREET, ROOM 340  
LOS ANGELES CA 90012  
(213) 367-4520  
Shanise.Black@ladwp.com  
For: Los Angeles Department of Water & Power

Barry F. Mc Carthy  
C. SUSIE BERLIN  
Attorney At Law  
MC CARTHY & BERLIN  
100 PARK CENTER PLAZA, SUITE 501  
SAN JOSE CA 95113  
(408) 288-2080  
bmcc@mccarthyllaw.com  
For: City of Anaheim; Northern California Power Agency;  
Turlock Irrigation District

Barry F. Mccarthy  
C. SUSIE BERLIN  
Attorney At Law  
MCCARTHY & BERLIN, LLP  
100 PARK CENTER PLAZA, SUITE 501  
SAN JOSE CA 95113  
(408) 288-2080  
bmcc@mccarthyllaw.com  
For: City of Anaheim, Northern California Power Agency,  
Turlock Irrigation District

Nicole Mason  
NEXT G NETWORKS OF CALIFORNIA, INC.  
2216 OTOOLE AVE.  
SAN JOSE CA 95131-1326  
(408) 719-8510  
nmason@nextgnetworks.net  
For: NextG Networks of California, Inc.

Norine Luker  
NEXT G NETWORKS OF CALIFORNIA, INC.  
2216 OTOOLE AVE  
SAN JOSE CA 95131-1326  
(408) 719-8510 X 185  
nluker@nextgnetworks.net

Robert L. Delsman  
Attorney At Law  
NEXTG NETWORKS OF CALIFORNIA, INC.  
2216 O TOOLE AVENUE  
SAN JOSE CA 95131  
rdelsman@nextgnetworks.net  
For: NextG Networks of California, Inc.

Patrick J. Geoffrey  
PACIFIC GAS & ELECTRIC COMPANY  
123 MISSION STREET  
SAN FRANCISCO CA 94105  
(415) 973-8096  
pjpg3@pge.com  
For: Pacific Gas & Electric Company

Grant Guerra  
PACIFIC GAS AND ELECTRIC COMPANY  
77 BEALE STREET, ROOM 3103  
SAN FRANCISCO CA 94105  
(415) 973-3728  
gxgw@pge.com  
For: Pacific Gas and Electric Company

Steven Cohn  
Chief General Counsel  
SACRAMENTO MUNICIPAL UTILITY DISTRICT  
6201 S STREET, M.S.B406 PO BOX 15830

Charles Manzuk  
SAN DIEGO GAS & ELECTRIC  
8330 CENTURY PARK COURT, CP 32D  
SAN DIEGO CA 92123  
(858) 636-5548  
cmanzuk@semprautilities.com  
For: SAN DIEGO GAS & ELECTRIC

Celeste Easton  
Attorney At Law  
SAN DIEGO GAS & ELECTRIC COMPANY  
555 WEST FIFTH STREET, STE. 1400  
LOS ANGELES CA 90013  
(213) 244-2942  
Ceaston@sempra.com  
For: San Diego Gas & Electric

Gregory L. Walters  
SAN DIEGO GAS & ELECTRIC COMPANY  
8316 CENTURY PARK COURT  
SAN DIEGO CA 92123  
(858) 654-8396  
gwalters@semprautilities.com  
For: San Diego Gas & Electric

Lori Ortenstone  
Attorney At Law  
SBC  
ROOM 1300  
101 W. BROADWAY  
SAN DIEGO CA 92101  
(619) 237-3329  
lori.ortenstone@att.com  
For: SBC California

Aimee M. Smith  
Attorney At Law  
SEMPRA ENERGY  
101 ASH STREET HQ13  
SAN DIEGO CA 92101  
(619) 699-5042  
amsmith@sempra.com  
For: San Diego Gas & Electric Company

Danielle Padula  
SOUTHERN CALIFORNIA EDISON  
2244 WALNUT GROVE AVENUE  
ROSEMEAD CA 91770  
(626) 302-6932  
danielle.padula@sce.com  
For: Southern California Edison

SACRAMENTO CA 95852-1830  
(916) 732-6121  
scohn@smud.org

Stephen H. Kukta  
Counsel  
SPRINT NEXTEL CORP.  
201 MISSION STREET, SUITE 1400  
SAN FRANCISCO CA 94105  
(415) 572-8358  
stephen.h.kukta@sprint.com  
For: Sprint Nextel Corp.

Suzanne Toller  
LEON BLOOMFIELD  
T-MOBILE  
1755 CREEKSIDE OAKS DRIVE, STE. 190  
SACRAMENTO CA 95833  
(916) 643-8926  
susan.lipper@t-mobile.com  
For: T-Mobile USA, Inc.

Anita Taff-Rice  
Attorney At Law  
1547 PALOS VERDES MALL, NO. 298  
WALNUT CREEK CA 94597  
(415) 699-7885  
anitataffrice@earthlink.net  
For: Clearlinx

Paul P. Strange  
Attorney At Law  
THE STRANGE LAW FIRM  
282 SECOND STREET, SUITE 201  
SAN FRANCISCO CA 94105  
(415) 243-3200  
strange@strangelaw.net  
For: SBC California (AT&T California)

Jesus G. Roman  
VERIZON CALIFORNIA, INC.  
112 S. LAKEVIEW CANYON ROAD, CA501LB  
THOUSAND OAKS CA 91362  
(805) 372-6233  
jesus.g.roman@verizon.com

Edward R. McGah, Jr.  
Attorney At Law  
VERIZON WIRELESS  
15505 SAND CANYON AVENUE  
IRVINE CA 92618  
(949) 286-8181  
Edward.McGah@verizonwireless.com  
For: Verizon Wireless

Bryan N. Tramont  
WILKINSON BARKER KNAUER, LLP  
2300 N. STREET, NW, SUITE 700  
WASHINGTON DC 20037-1128  
(202) 783-4141  
btramont@wbklaw.com  
For: Verizon Wireless

Leon M. Bloomfield  
Attorney At Law  
WILSON & BLOOMFIELD LLP  
1901 HARRISON STREET, SUITE 1620  
OAKLAND CA 94612  
(510) 625-8250  
lmb@wblaw.net  
For: Wireless Group-Cingular,Crown Castle,NextG Networks of  
California,Sprint,T-Mobile &Verizon Wire

\*\*\*\*\* STATE EMPLOYEE \*\*\*\*\*

Andrew Campbell  
Executive Division  
RM. 5304  
505 VAN NESS AVE  
San Francisco CA 94102  
(415) 703-2501  
agc@cpuc.ca.gov

Richard Clark  
Consumer Protection & Safety Division  
RM. 2205  
505 VAN NESS AVE  
San Francisco CA 94102  
(415) 703-2349  
rwc@cpuc.ca.gov

Raymond G. Fugere  
Consumer Protection & Safety Division  
RM. 500  
320 WEST 4TH STREET SUITE 500  
Los Angeles CA 90013  
(213) 576-7015  
rgf@cpuc.ca.gov

Peter Hanson  
Executive Division  
RM. 4104  
505 VAN NESS AVE  
San Francisco CA 94102  
(415) 703-1053  
pgh@cpuc.ca.gov



Raffy Stepanian  
Consumer Protection & Safety Division  
RM. 500  
320 WEST 4TH STREET SUITE 500  
Los Angeles CA 90013  
(213) 576-7019  
rst@cpuc.ca.gov

Glen Walker  
Administrative Law Judge Division  
RM. 5106  
505 VAN NESS AVE  
San Francisco CA 94102  
(415) 703-1232  
gew@cpuc.ca.gov

\*\*\*\*\* INFORMATION ONLY \*\*\*\*\*

Sarah Beserra  
39 CASTLE HILL COURT  
VALLEJO CA 94591  
sbeserra@napanet.net

Margaret Felts  
President  
CALIFORNIA COMMUNICATIONS ASSN  
1851 HERITAGE LANE STE 255  
SACRAMENTO CA 95815-4923  
(916) 567-6700  
mcf@calcomwebsite.com

CALIFORNIA ENERGY MARKETS  
517-B POTRERO AVENUE  
SAN FRANCISCO CA 94110  
(415) 552-1764 X 17  
cem@newsdata.com

Cindy Manheim  
CINGULAR WIRELESS  
PO BOX 97061  
REDMOND WA 98073-9761  
(425) 580-8112  
cindy.manheim@cingular.com  
For: Cingular Wireless

George Granger  
V.P. External Affairs  
CINGULAR WIRELESS  
4420 ROSEWOOD DRIVE, 4TH FLOOR  
PLEASANTON CA 94588  
(925) 227-3070  
george.granger@cingular.com

Alison Kott  
Deputy City Attorney  
CITY OF ANAHEIM  
200 S. ANAHEIM BLVD., SUITE 356  
ANAHEIM CA 92805  
(714) 765-5169  
akott@anaheim.net  
For: CITY OF ANAHEIM

David Hurlburt  
Safety Committee Chair  
COMMUNICATION WORKERS OF AMERICA 9410  
240 - 2ND ST.  
SAN FRANCISCO CA 94105  
(415) 777-9410  
dghurlb@pacbell.net  
For: Local 9410 Communication Workers of America

Holly Ernst Groschner  
Vice President - Legal  
CROWN CASTLE  
2000 CORPORATE DRIVE  
CANONSBURG PA 15317  
(724) 416-2442  
holly.groschner@crowncastle.com

Louie Rocha  
President  
CWA LOCAL 9423  
2015 NAGLEE AVENUE  
SAN JOSE CA 95128  
(408) 278-9423  
louierocha@cwa9423.com

Judy Pau  
DAVIS WRIGHT TREMAINE LLP  
505 MONTGOMERY STREET, SUITE 800  
SAN FRANCISCO CA 94111-6533  
(415) 276-6587  
judypau@dwt.com

Donald E. Hooper  
ES&C, INC.  
116 STOCKTON AVENUE  
OCEAN GROVE NJ 07756  
(732) 988-2685  
hooperjd@verizon.net  
For: CCTA

David Porte  
FASTBALL PARTNERS  
87 DEPOT ROAD, SUITE 250  
HARVARD MA 01451

For: Cingular Wireless

(617) 512-4402  
porte@fastballpartners.com

W. Lee Biddle  
Attorney At Law  
FERRIS & BRITTON  
401 WEST A STREET, SUITE 1600  
SAN DIEGO CA 92101  
(619) 233-3131  
lbiddle@ferrisbritton.com

Judy Robb  
Cousultant, Facilitator, Trainer  
ROBB GROUP  
3539 MENDENHALL COURT  
PLEASANTON CA 94588  
(925) 931-0965  
robbgroup@earthlink.net  
For: ROBB GROUP

C. Susie Berlin  
Attorney At Law  
MC CARTHY & BERLIN, LLP  
100 PARK CENTER PLAZA, SUITE 501  
SAN JOSE CA 95113  
(408) 288-2080  
sberlin@mccarthylaw.com  
For: NORTHERN CALIFORNIA POWER AGENCY

David Dohren  
SAN DIEGO GAS & ELECTRIC COMPANY  
8316 CENTURY PARK COURT, CP51D  
SAN DIEGO CA 92123  
(858) 654-8777  
ddohren@semprautilities.com  
For: SAN DIEGO GAS & ELECTRIC COMPANY

Frances Yee  
PACIFIC GAS AND ELECTRIC COMPANY  
77 BEALE STREET, MC B8R  
SAN FRANCISCO CA 94105  
(415) 973-6057  
fsc2@pge.com

Central Files  
SAN DIEGO GAS AND ELECTRIC COMPANY  
8330 CENTURY PARK COURT, CP31E  
SAN DIEGO CA 92123  
(858) 654-1240  
centralfiles@semprautilities.com  
For: SEMPra ENERGY UTILITIES

Larry Nixon  
PACIFIC GAS AND ELECTRIC COMPANY  
77 BEALE STREET, MC B10A  
SAN FRANCISCO CA 94105  
(415) 973-5450  
lrn3@pge.com

Anthony Rabe  
SBC  
3707 KINGS WAY, RM. C33A  
SACRAMENTO CA 95851  
(916) 972-4173  
ar2536@sbc.com  
For: SBC

Law Department File Room  
PACIFIC GAS AND ELECTRIC COMPANY  
PO BOX 7442  
SAN FRANCISCO CA 94120-7442  
cpuccases@pge.com

Mark Lyons  
SIMPSON PARTNERS LLP  
SUITE 1800  
TWO EMBARCADERO CENTER  
SAN FRANCISCO CA 94111  
(415) 732-1701  
marklegal@sbcglobal.net

Peter Van Mieghem  
Attorney At Law  
PACIFIC GAS AND ELECTRIC COMPANY  
77 BEALE STREET, ROOM 3107  
SAN FRANCISCO CA 94105  
(415) 973-2902  
ppv1@pge.com

Case Administration  
SOUTHERN CALIFORNIA EDISON COMPANY  
2244 WALNUT GROVE AVENUE  
ROSEMEAD CA 91770  
case.admin@sce.com

Roxanne Piccillo  
PACIFIC GAS AND ELECTRIC COMPANY  
77 BEALE STREET, B8R  
SAN FRANCISCO CA 94105  
(415) 973-6593  
rtp1@pge.com

Richard Tom  
Attorney At Law  
SOUTHERN CALIFORNIA EDISON COMPANY  
2244 WALNUT GROVE AVENUE  
ROSEMEAD CA 91770

(626) 302-4430  
richard.tom@sce.com

Jay Baumler  
Implementation Manager  
SPRINT PCS  
18200 VON KARMAN, SUITE 100  
IRVINE CA 92612  
(949) 623-5997  
Jay.M.Baumler@sprint.com  
For: Sprint PCS

Jacque Lopez  
Legal Assistant  
VERIZON CALIFORNIA INC  
CA501LB  
112 LAKEVIEW CANYON ROAD  
THOUSAND OAKS CA 91362  
(805) 372-6664  
jacque.lopez@verizon.com

Marcel Hawiger  
Attorney At Law  
THE UTILITY REFORM NETWORK  
711 VAN NESS AVENUE, SUITE 350  
SAN FRANCISCO CA 94102  
(415) 929-8876  
marcel@turn.org

Charles A. Johnson  
VERIZON CALIFORNIA INC.  
201 FLYNN ROAD, MC CAM38NE2  
CAMARILLO CA 93012  
(805) 388-5077  
chuck.johnson@verizon.com

Regina Costa  
THE UTILITY REFORM NETWORK  
711 VAN NESS AVENUE, SUITE 350  
SAN FRANCISCO CA 94102  
(415) 929-8876 X312  
rcosta@turn.org

Lorraine A. Kocen  
VERIZON CALIFORNIA INC.  
112 S. LAKEVIEW CANYON ROAD, CA501LS  
THOUSAND OAKS CA 91362-3831  
(805) 372-6945  
Lorraine.Kocen@verizon.com

Margaret Tobias  
Attorney At Law  
TOBIAS LAW OFFICE  
460 PENNSYLVANIA AVE  
SAN FRANCISCO CA 94107  
(415) 641-7833  
info@tobiaslo.com

Michael Bagley  
VERIZON WIRELESS  
15505 SAND CANYON AVENUE  
IRVINE CA 92612  
(949) 286-8008  
michael.bagley1@verizonwireless.com

Brian Lafollette  
TURLOCK IRRIGATION DISTRICT  
PO BOX 949  
333 EAST CANAL DRIVE  
TURLOCK CA 95381-0949  
(209) 883-8396  
bll@tid.org

Casey Hashimoto  
TURLOCK IRRIGATION DISTRICT  
333 CANAL DRIVE  
TURLOCK CA 95380  
(209) 883-8242  
cjhashimoto@tid.org

Michael Shames  
Attorney At Law  
UTILITY CONSUMERS' ACTION NETWORK  
3100 FIFTH AVENUE, SUITE B

SAN DIEGO CA 92103  
(619) 696-6966  
mshames@ucan.org

**(END OF APPENDIX A)**

# Pole Attachments 101

---

Attachment C, Item 9

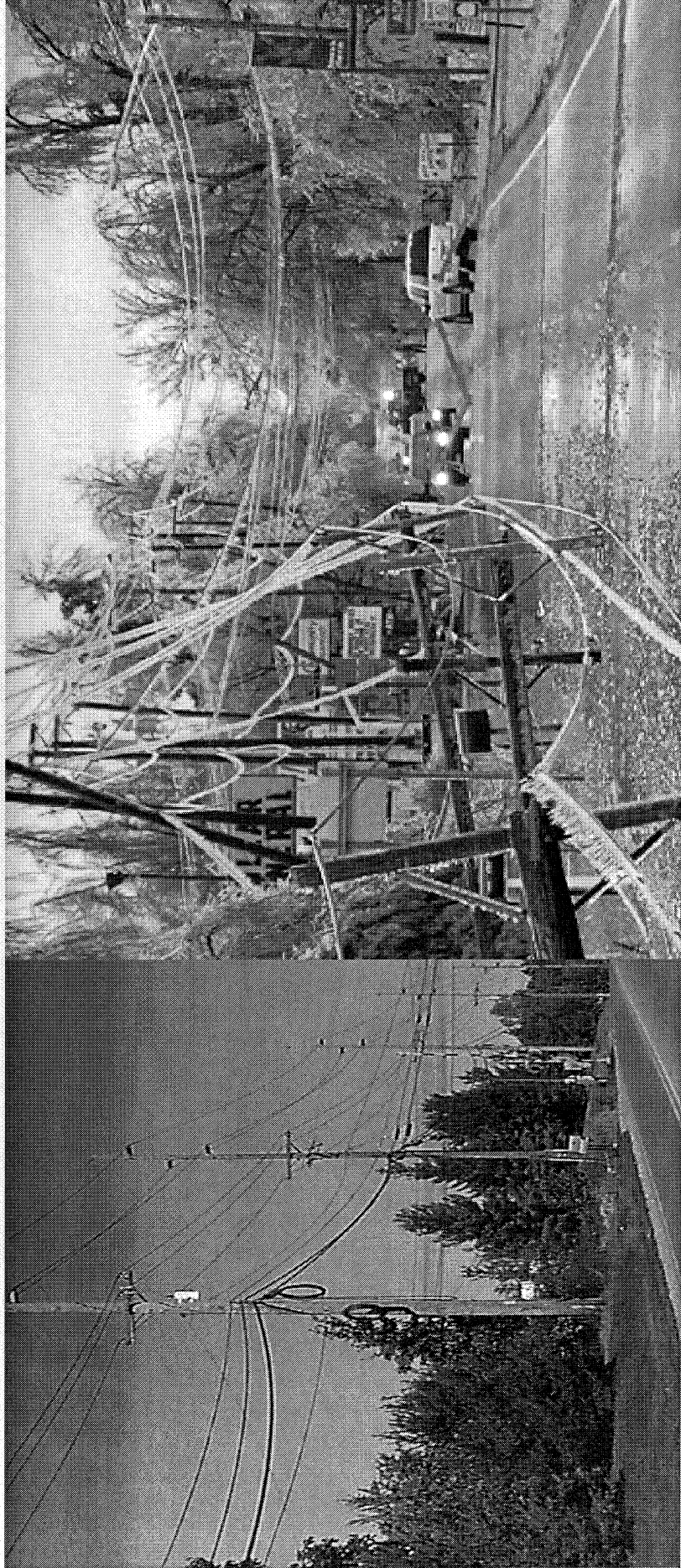

# Overview

---

- Joint use vs. pole attachments
- Pole attachments
  - Access is mandatory
  - Rates are subsidized by utility customers
- Effect on the safety, integrity and reliability of critical infrastructure
- Pole attachment issues should be comprehensively addressed in 2006 telecommunications legislation:
  - Safety and reliability
  - Jurisdiction
  - Rates





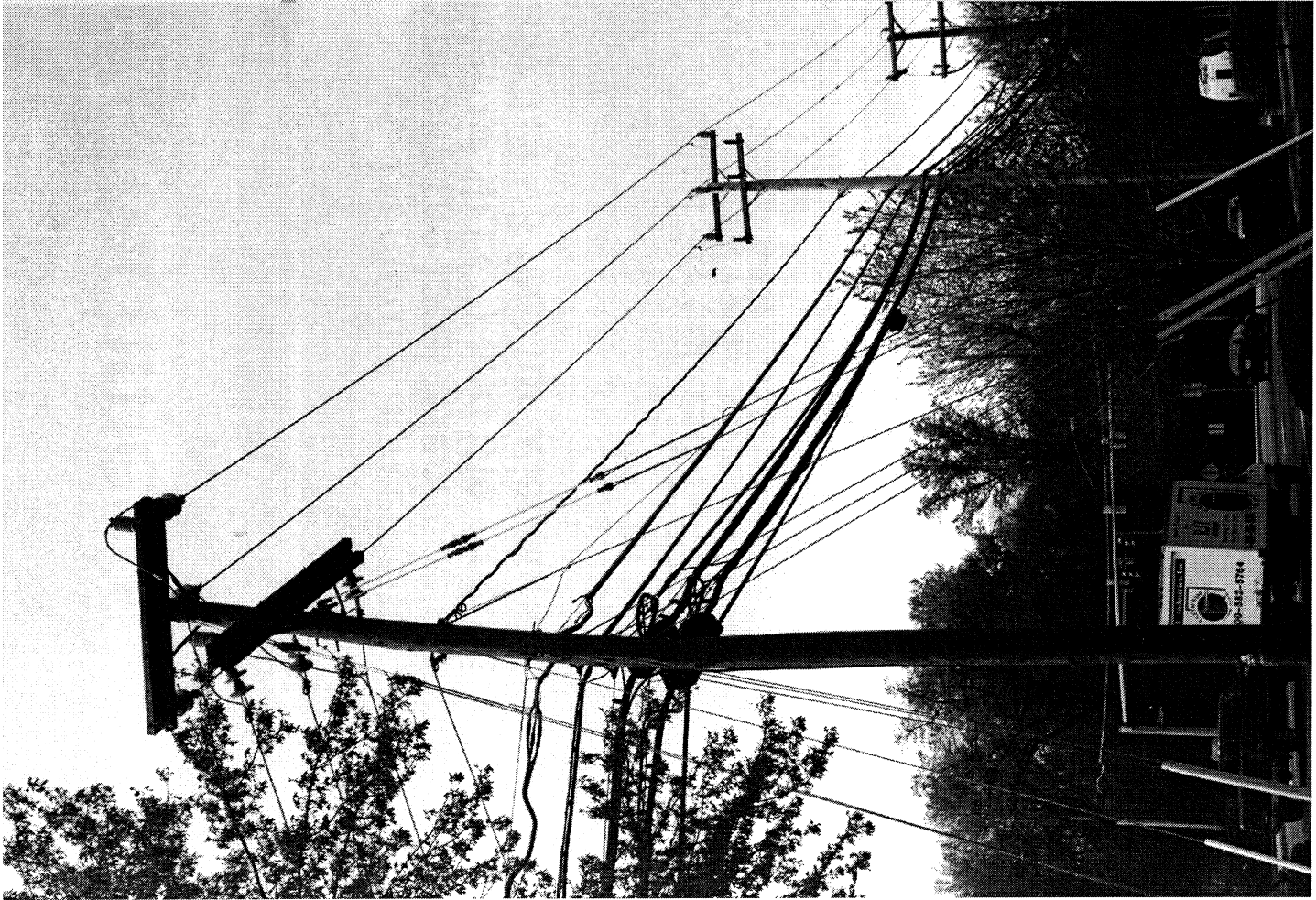

# An Illustrative Joint Use Pole with Pole Attachments

# Joint Use and Pole Attachments

There is a difference

---

- **Joint use** is sharing the use of poles, by mutual agreement, between pole-owning utilities, typically the local telephone company (Incumbent Local Exchange Carrier or "ILEC") and the electric utility. Space required is generally 1.5 - 3 feet for telephone attachments.
  
- **Pole attachments**, originally by mutual agreement but later by federal statute and regulation, provide non-pole-owning cable and telecommunication service providers (e.g. Cable TV, Competitive Local Exchange Carriers or "CLECs") with access to a utility's distribution poles, conduits, and rights of way for:
  - Installing fiber, coaxial cable or wires, and other equipment;
  - Building an interconnected network; and
  - Reaching customers.Space requested for pole attachments is typically one foot.



**EDISON ELECTRIC  
INSTITUTE**



# Background: Joint Use

## Purposes and Examples of Cost-Sharing Methods

---

- Joint use purposes are simple:
  - Reduce the cost to consumers;
  - Share the high cost of infrastructure fairly and equitably;
  - Minimize the visual impact of two separate pole networks; and
  - Minimize roadway hazards.
- Common joint use cost-sharing methods:
  - Shared burden of ownership with each party owning a similar number of joint use poles (i.e., parity);
  - Joint ownership of each joint use pole; and
  - Other methods used in some regions.

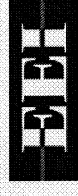

# Background: Joint Use

## Maintaining Parity and Sharing Other Costs

---

- Many joint use agreements provided for a nominal fee (\$2 to \$3) that the party with the fewer number of joint use poles paid to the party with the greater number of poles, as an incentive to reestablish parity.
- Many agreements required the party with the fewer number of joint use poles to set new poles until parity was again restored.
- Some divided the responsibility for different aspects of the associated maintenance work.
- Little or no money would change hands.



# Background: Joint Use

## What Changed

---

- Some ILECs began to see the \$2 to \$3 incentive/joint use charges as a bargain “pole attachment rate” and abandoned the setting of joint use poles.
- Failing to set poles and maintain parity can be a violation of the terms of joint use agreements.
- For many reasons, over time electric utilities came to own the majority of joint use poles.





# Background: Joint Use

## Consequences For Electric Utilities

---



Ownership burdens (capital costs, operation, pole and right of way maintenance) fell to electric utilities and their customers.

Telephone utilities divested vehicles and equipment, personnel and contractors for setting and maintaining poles.

Electric utilities became principally responsible for emergency storm restoration, even for ILEC-owned poles used by electric utilities.



**EDISON ELECTRIC  
INSTITUTE**

# Background: Joint Use

## Joint Use Rates

---

- Some joint use agreements have been renegotiated recently, to more accurately reflect:
  - New ownership realities (i.e., majority electric); and
  - Different amount of space now used by ILECs.
  
- A negotiated rate methodology was established to divide the annual cost of owning a joint use pole between the electric and telephone companies.
  
- Key determinants are:
  - Percent of pole space used by each utility;
  - Annual cost to an owner of maintaining a pole; and
  - Annual cost to an owner for capital expense and return.



# Summary of Joint Use

---

- Joint use arose between electric and telephone utilities.
- Since both utilities are regulated by the state PUC, so are their contracts and relations with each other.
- Agreements originally based upon parity, but evolved to allocate costs when telephone companies stopped setting or owning poles.
- Cost allocation designed to prevent subsidization by electric and telephone utility customers.





# Pole Attachments

## Pole Attachment Act of 1978

---

- Investor-owned electric and telephone utilities first subjected to FCC pole attachment regulation.
- Provided low (i.e., subsidized) “pole attachment” rates to cable TV.
- Government-owned utilities (TVA, PMAs, municipal, etc.), cooperatives (telephone and electric) and railroads are exempt.
- Policy goal: to encourage a new market entrant (cable TV) to enter the video business.
- Did not address protection of the utility system.

# Pole Attachments

Telecommunications Act of 1996 – Access

---

- Intended to promote competition in telecommunication and cable markets.
- Access rights expanded to include telecommunications providers.
- Access to utility poles made mandatory.
  - Exception made for utilities only where there is "insufficient capacity and for reasons of safety, reliability and generally applicable engineering purposes."



**EDISON ELECTRIC  
INSTITUTE**



# Pole Attachments

Access Issues – FCC Regulation under 1978 & 1996 Acts

---

## Examples of problems:

- Has allowed pole attachments without notification (prevents engineering evaluation for pole strength, clearances, grounding, guying etc.).
- Has allowed “overlashing” of existing attachments with additional facilities without notification.
- Has compromised safety and reliability requirements for the installation of cable or telecommunications facilities.
- Has often failed to support utility efforts to inspect for safety violations and capacity overloading.

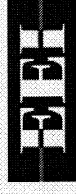

# Pole Attachments

## Telecommunications Act of 1996 – Rates

---

- Continued the subsidized cable TV attachment rate for, “any pole attachment used by a cable television system solely to provide cable service.”
- Established the possibility for a slightly higher, yet still subsidized attachment rate for, “pole attachments used...to provide any telecommunications services” (“CLEC rate”).
- Deferred the CLEC rate until 2001, and the lower Cable rate was continued. Any increase to the CLEC rate was phased in over 5 years, 2001-2006.
- Excluded ILECs from the new CLEC rate, because they were excluded from the definition of “telecommunications carriers.”



# Joint Use And Pole Attachments

## Rate Summary – Typical Example

---

### Joint Use rates:

- Joint use ILEC rate = \$ 40.80 (2 party cost share)

### Pole Attachment rates:

- FCC Cable TV rate = \$ 6.63 (subsidized)
- FCC CLEC rate after 2006:
  - "urban" = \$ 10.02 (subsidized)
  - "rural" (rare) = \$ 15.12 (subsidized)

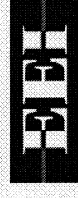



# Pole Attachments

Telecommunications Act of 1996 – Competitive Disparity

---

- ILECs (and electric utilities) are subject to existing joint use agreements.
- Cable TV companies get mandatory access, cable-only rates
  - Some potentially could move to a CLEC rate...if the FCC ever decides to act on cable-provided telephone service (VoIP).
- Other telecommunications providers get mandatory access and the slightly higher CLEC rate.
- Electric and ILEC customers are subsidizing cable companies and other telecommunications providers.



**EDISON ELECTRIC  
INSTITUTE**

# Pole Attachment Rates

What The Competitively Neutral Methodology Should Be

---

- Each entity should pay for the space it uses.
- Each entity should share equally in the cost of all other space on the pole.
- No distinction among:
  - Types of companies (cable or CLEC);
  - Types of service (internet, cable or telephone); or
  - Types of wireline facility installed (fiber, coaxial cable or twisted pair).

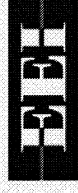

# Pole Attachments

## Effect on Critical Infrastructure

---

- Competitive access has been the primary emphasis of federal legislation and regulation.
- Infrastructure protection and proper cost allocation have not been adequately addressed.
- Pole attachments substantially affect the safety and reliability of the infrastructure upon which electric, telephone, cable, and other communications services rely.



**EDISON ELECTRIC  
INSTITUTE**



# Pole Attachments

## Effect on Critical Infrastructure

---

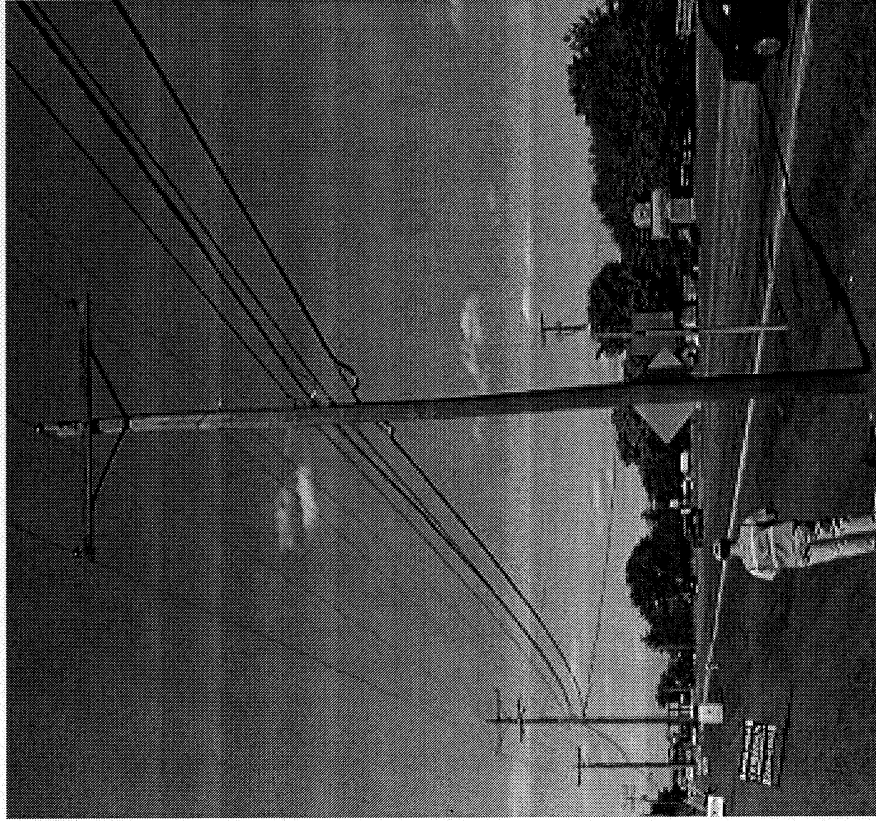

Electric and Telephone distribution infrastructure are critical components used to provide electric and communications services to homes, businesses and government.

Public safety agencies, energy production and delivery, financial markets, telecommunications, transportation, health care, clean water and sanitation – all depend on reliable electric and communications services.



**EDISON ELECTRIC  
INSTITUTE**

# Pole Attachments

Effect on Critical Infrastructure

---

Attachments to electric and telephone distribution infrastructure affect:

- Structural integrity, safety, security, reliability;
- Operation and maintenance costs;
- Susceptibility to damage in ice and wind storms;
- Restoration following natural disasters and other emergencies; and
- Public and employee safety.



**EDISON ELECTRIC  
INSTITUTE**



# New Proposed Federal Legislation

## Joint Use / Pole Attachments – Access and Rates

---

- Proposed telecom legislation raises issues related to joint use / pole attachment access rights and rates, in order to promote video competition.
  
- Both the Ensign–McCain bill (S. 1504) and the Barton staff discussion draft would:
  - In effect, extend subsidized pole attachment rates to all providers, including ILECs; and
  - Threaten existing joint use agreements.

## Pole Attachments

Should Be Addressed in Telecommunications Legislation

---

- 1978 and 1996 federal legislation focused almost exclusively on mandatory access and subsidized rates for cable TV and telecommunications companies (albeit slightly higher than cable).
- Safety, integrity and reliability issues important to the protection of critical electric and telecommunications infrastructure have not been adequately addressed.



EDISON ELECTRIC  
INSTITUTE

# Electric Industry Priorities

## Safety and Reliability

---

Protect critical wireline infrastructure that supports both electric and communications services by providing for:

- Agreements between the parties;
- Certification of the number of attachments;
- Attachment notification; and,
- Payment of “make-ready” costs (e.g., planning, engineering & construction).



# Electric Industry Priorities

## Rates

---

### Eliminate subsidies and preferential treatment:

- Eliminate pole attachment subsidies to communication giants;
- End preferential treatment of different communication technologies; and
- Ensure that all costs of critical wireline infrastructure are shared proportionally among those using it.
- Recommended Annual Pole Cost allocation formula:
  - Space used by attaching party as % of usable space; and
  - Equal share of all other space among all paying attachers, including the pole owner.



# Electric Industry Priorities

## Jurisdiction

---

Shift regulatory focus to the states:

- Local wireline infrastructure safety, integrity, and reliability is largely dependent on local circumstances (e.g., geography, weather) and failures have local consequences (e.g., service interruptions, power outages);
- State commissions are uniquely experienced and qualified to oversee local electric and communications service, and they already do so;
- Local oversight, not national policy, already applies to most underground telecommunications facilities (e.g., “street cuts”); and
- The state commissions are the only regulatory body representing the consumer interest of both electric and communications consumers.

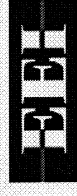

# Electric Industry Priorities

## Existing Joint Use Agreements

---

- No abrogation of existing joint use agreements with ILECs.
- Existing contracts were freely negotiated and have adequate modification and termination provisions.



**EDISON ELECTRIC  
INSTITUTE**



# For More Information

---

Contact:

Washington Representative  
for your shareholder-owned electric utility

Or

Edison Electric Institute

[www.eei.org](http://www.eei.org)

202.508.5000

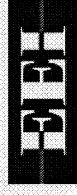

EDISON ELECTRIC  
INSTITUTE





Attachment C, Item 10  
Please See Attachment C, Item 2

*Attachment C,*

**Guidelines for the** *Item 11*

**Attachment of**  
**Communication Antennas**  
**to AEP Transmission**  
**Structures**

**May 7, 2002**

Date: \_\_\_\_\_

**Mike Higgins**  
**Director, Transmission Maintenance & Standards**

Date: \_\_\_\_\_

**James Berger**  
**Director, Transmission Line Projects Engineering**

# AEP Transmission Structure Antenna Attachment Guidelines

- I. Description
  - A. This document establishes general guidelines set forth by AEP Transmission Line Projects Engineering in co-locating wireless carriers, Personal Communication System (PCS), on AEP transmission structures
  
- II. Supplemental Easement Acquisition
  - A. Procedures outlined in the AEP Transmission Line Engineering System Right of Way Policies and Procedures Manual will be followed during supplemental easement acquisition under the section entitled "Acquisition of PCS Sites".
  - B. All zoning requirements shall be handled by the wireless carrier. AEP Transmission Line Projects Engineering ("TLPE") will provide any necessary supporting data such as tower height or antenna mount. AEP TLPE Right-of-Way will verify that all zoning requirements have been satisfied by the carrier. AEP TLPE Right-of-Way will supply the PCS Coordinator and AEP Transmission Line Projects Engineering and Design Standards ("TLPEDS") with any special restrictions mandated by the local zoning authority which may affect the engineering & design of the antenna mount. AEP Transmission Services will also be notified of the restrictions if construction of the site is affected.
  
- III. Shelter and Equipment Dimensions Associated with Transmission Towers
  - A. It is preferred that all PCS equipment be placed within the footprint of the transmission tower. When cabinets, shelters, and other miscellaneous equipment are placed within the footprint of the transmission tower, a minimum clearance of two feet shall be maintained to all tower members in the placement of such equipment during construction. A minimum distance of five feet shall be maintained between all permanent equipment (including fencing) and the nearest tower member. The location of shelters, cabinets, and equipment placed outside the tower footprint shall be approved by TLPEDS.

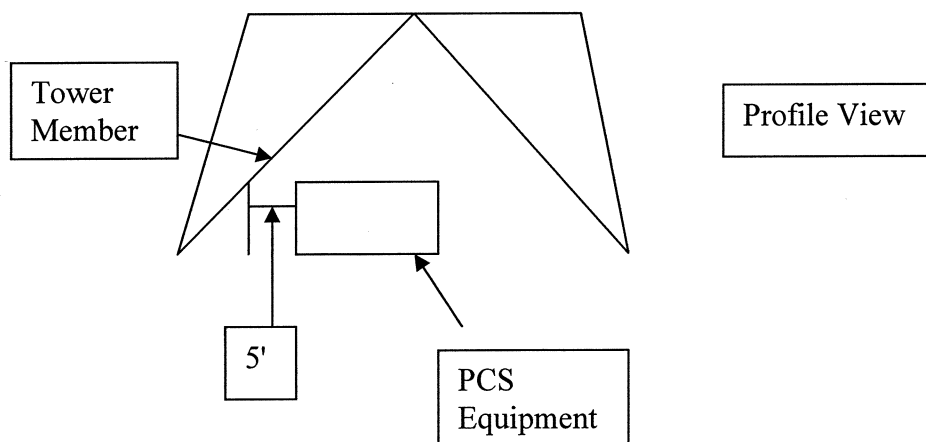

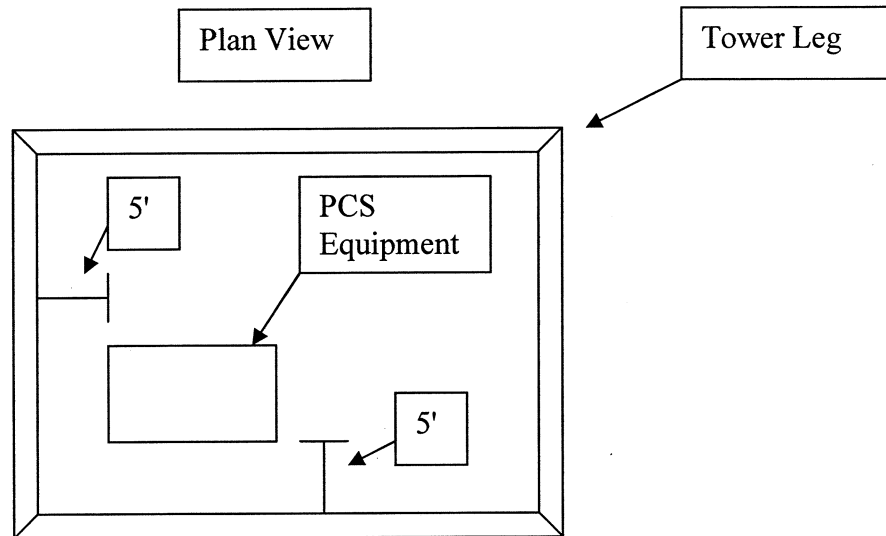

- B. Shelters and cabinets placed within the footprint of the tower:
1. On transmission towers, ice bridges are permitted within the footprint.
  2. Space within the tower footprint shall be utilized efficiently to maximize the number of carriers on each transmission tower. A carrier shall not place equipment or fencing directly within the center of the footprint, but off to one side of the footprint to enable use by another carrier. This practice shall be enforced by civil drawing review by the PCS Coordinator.

- C. Shelters and cabinets placed outside the footprint of the tower:
- a. On transmission towers, ice bridges are permitted. Trenching shall be used when the ice bridge run exceeds 15 feet.
  - b. Shelters, cabinets, and associated equipment (including fencing) shall be placed no closer than 15' to the nearest tower leg. Exceptions to this must be approved by TLPE.

IV. Shelter and Equipment Dimensions Associated with Transmission Poles

- A. Shelters, cabinets and other equipment comparable in size shall be permitted in the right-of-way adjacent to towers and wood/steel/concrete pole locations (Includes single and two pole locations). Permanent equipment shall be placed no closer than 15 feet to the nearest pole or tower leg. Exceptions to this must be approved by TLPE.
- B. Although trenching is preferred on single pole and two pole structures, an ice bridge can be used if the run does not exceed 15 feet from the pole to the associated equipment. Trenching shall be used when the ice bridge run exceeds 15 feet.

## V. Structure Access

- A. Coax and all other associated cables and lines running from the tower or pole to a shelter placed along the edge of the right-of-way shall be trenched (Ice bridge run not permitted to the edge of the right-of-way). The carrier will be responsible for appropriate trenching installation and maintenance as AEP will not be responsible for any damaged coax or cable after installation is completed. Appropriate trenching details should be reflected on the civil drawings produced by the carrier.
- B. Placement of permanent equipment or fencing shall not hamper standard ingress and egress requirements by AEP Transmission Services. It is preferred that no portion of AEP towers and/or poles be enclosed in a Carrier's fenced area. Proper ingress and egress requirements shall be enforced during the civil drawing review performed by the PCS Coordinator. Requirements will vary at each site due to restraints dictated by general terrain, road access, line voltage, outage requirements, outage constraints, and structure type.
- C. Access road issues and other miscellaneous site issues will be handled by TLPE through the PCS Coordinator.

## Electrostatic and Grounding Requirements

- A. Clearance from the antenna and associated cables, waveguides, etc. to conductor shall be checked by TLPEDS during engineering of the attachment mount. The clearance shall conform to TLES-10 guidelines under "Clearance Checks To Communication Antennas".
- D. Possible phase-to-ground equipment clearance issues will be monitored by the PCS Coordinator during review of carrier site drawings. The drawings will be presented to TLPE for review if potential problems exist. Grounding of PCS Structures and equipment should follow industry standard guidelines to assure the safety of utility employees and the general public. Generally, the communications equipments (and fencing grounds) should be bonded to the utility grounds or the tower legs.

## VII. Engineering

- A. Structural analysis and antenna mount material ordering will be performed by TLPEDS. Antenna and coax mounting details will be provided to TLPEDS by the PCS Coordinator. TLPEDS will provide a material quotation to the Manager of Associated Business Development ("ABD").
  1. TLPEDS will supply all applicable erection drawings and furnish a copy of the structural analysis to the carrier if required by the carrier.
  2. Structural analysis will be based on loading criteria for transmission towers set forth by the National Electric Safety Code ("NESC") and by AEP. TIA/EIA telecommunication loading criteria does not apply to transmission towers and will not be considered in the structural analysis. 
- B. Decisions regarding mounting types shall be made by TLPEDS. The PCS Coordinator may make decisions on structure types that already have mounts. The information provided to the carrier should be qualified with

a statement regarding the requirement of a structural analysis to ensure structural adequacy.

- C. Final civil drawings will be provided by the carrier and will be reviewed and approved by the PCS Coordinator with the assistance of TLPE (if needed).
- D. The PCS Coordinator will ensure that TGIS and plan & profile is updated by TLPE. The PCS Coordinator will submit updates with necessary supporting information to the appropriate TLPE Line Manager.

#### VIII. PCS Tower Construction

- A. All antenna and coax attachments to the tower will be performed by AEP company crews or an AEP designated contractor. The Carrier may select its own contractor to perform the civil work. While working with equipment under or adjacent to a transmission structure, the contractor must meet all safety codes and all mandated OSHA requirements.
  - 1. All civil work performed by an independent contractor shall be under the supervision of the Transmission Construction Management in Transmission Capital Improvements.
- B. Work responsibility shall be transferred from AEP crews to the civil contractor at the base of the tower. The civil contractor shall not perform any work on the transmission tower without the consent of AEP Transmission Services.
- C. The Carrier shall be responsible for ordering power and telco to the site.
- D. All line outage requirements will be verified through AEP Operations by the PCS Coordinator.

#### IX. Summary

- A. The PCS Coordinator will communicate all necessary steps of action between the various groups and provide customer requested deadlines.
- B. ABD will negotiate all master and site license agreements and shall be responsible for the overall administration of the PCS program.
- C. The PCS Coordinator will monitor the removal of any PCS Carrier facilities from AEP Transmission Structures. The PCS Coordinator will ensure that TGIS and plan & profile are updated by TLPE. The PCS Coordinator will submit updates with necessary supporting information to the appropriate TLPE Line Manager.

*Attachment C, Item 12*



**EDISON ELECTRIC  
INSTITUTE**

THOMAS R. KUHN  
President

June 16, 2006

The Honorable Ted Stevens  
Chairman  
Committee on Commerce,  
Science and Transportation  
United States Senate  
Washington, DC 20510

The Honorable Daniel K. Inouye  
Ranking Member  
Committee on Commerce,  
Science and Transportation  
United States Senate  
Washington, DC 20510

Dear Chairman Stevens and Senator Inouye:

As the Committee on Commerce, Science and Transportation moves to mark up communications reform legislation, I want to bring to your attention two issues of importance to shareholder-owned electric utilities – pole attachments and broadband over power lines (BPL) technology.

On behalf of the Edison Electric Institute, the national association of shareholder-owned electric utilities, I urge you to: (1) address longstanding critical wireline infrastructure cost-sharing, safety and reliability issues by adopting comprehensive pole attachment reforms, and reject proposals to perpetuate or expand current pole attachment subsidies; and (2) reject efforts to delay BPL deployment.

Pole Attachments

Your committee is considering telecommunications legislation that could potentially address pole attachment issues. Some are suggesting proposals to perpetuate—and expand—the subsidies that now benefit cable and telecommunications companies, while failing to address critical infrastructure issues caused by pole attachments. Fortunately, no such language is included in the current revised substitute version of S. 2686, the communications reform bill pending in the Commerce Committee. However, we would strongly oppose proposals to perpetuate or expand pole attachment subsidies if offered as amendments to the bill.

EEI and its member companies support resolving longstanding rate inequities, and safety and reliability issues, associated with pole attachments. We urge the inclusion of provisions in S. 2686 to eliminate pole attachment subsidies to communications giants currently borne by electric customers. Pole attachment rates should reflect a full and fair allocation of utilities' actual costs for constructing and maintaining critical wireline infrastructure. In addition, Congress should ensure that pole attachments are installed and maintained in compliance with all applicable safety, reliability, and engineering standards, and that utilities are properly informed about non-utility wires attached to their poles.

The nation's electric distribution systems—including poles, ducts, conduits, and rights-of-way—deliver power along millions of miles of lines to electricity consumers and are a key part of the nation's critical energy infrastructure. Under current federal law, cable and other telecommunications companies can attach their wires to electric utility poles at subsidized rates, which were originally created to boost then-nascent video and communications services. These subsidies, now obviously outdated, are ultimately paid for by electricity consumers in their utility rates.

Pole attachments also affect the structural integrity, safety, security, and reliability of the electric distribution infrastructure, and they increase operation and maintenance costs for electric utilities and their customers. But current law is largely silent on these critically important issues. For instance, many pole attachments fail to meet minimum safety code standards, and attaching entities are able to avoid having to notify utilities when they attach their wires to utility poles or add additional lines to existing attachments. Providing clear and uniform statutory standards will benefit electricity, video and communications customers who rely on services provided over wireline infrastructure.

#### Broadband over Power Lines

We also encourage you and other Senators on your committee to reaffirm your commitment to additional competition in broadband services by resisting attempts to further delay rollout of BPL as you consider S. 2686.

BPL is an exciting new technology that uses existing power lines to provide an alternate, competitive means of broadband access. In addition, BPL can improve the reliability and efficiency of electric service through a variety of load management applications. After two years of exhaustive consideration, the Federal Communications Commission (FCC) in 2004 promulgated technical rules, endorsed by the National Telecommunications and Information Administration (NTIA) and the Federal Energy Regulatory Commission (FERC), which adequately protect amateur radio users against potential BPL interference.

H.R. 5252, the communications bill recently approved by the House of Representatives, would require the FCC to perform yet another study of BPL interference issues. This redundant FCC study would only further delay the deployment of BPL as a competitive alternative for consumers seeking broadband services, as well as impeding efforts to improve electric reliability and energy efficiency.

Again, I urge your Committee to: (1) reject proposals to perpetuate or expand pole attachment subsidies and instead consider comprehensive pole attachment reform; and (2) reject efforts to delay BPL deployment. I appreciate your attention to these two very important issues.

Sincerely,



Thomas R. Kuhn

TRK:coc

cc: Members, Committee on Commerce, Science and Transportation



*Attachment C, Item 13*

**STATEMENT FOR THE RECORD  
SUBMITTED BY  
EDISON ELECTRIC INSTITUTE**

**COMMITTEE ON COMMERCE, SCIENCE AND TRANSPORTATION  
UNITED STATES SENATE**

**HEARING ON  
STATE AND LOCAL ISSUES AND MUNICIPAL NETWORKS**

**FEBRUARY 14, 2006**

Mr. Chairman and Members of the Committee:

Edison Electric Institute (EEI) is pleased to submit this statement for the record to the Committee. EEI is the premier trade association for U.S. shareholder-owned electric companies and serves international affiliates and industry associates worldwide. EEI's members serve 97 percent of the ultimate customers in the shareholder-owned segment of the industry and 71 percent of all electric utility ultimate customers in the nation.

EEI member companies share a longstanding common commitment to maintaining the safety, security, reliability, and structural integrity of the nation's critical electric infrastructure, which is essential not only to the electric industry but also to the cable and communications industries that are attached to it. That is why we have concerns with the "pole attachment" provision [Section 13 (f)(1)] of the "Broadband Investment and Consumer Choice Act" [S. 1504] introduced by Senators Ensign and McCain, which addresses the rates, terms, and conditions for access by third parties to electric utility poles, ducts, conduits, and rights-of-way.

Under current law, cable and telecommunications companies are allowed to attach their wires to utility poles at subsidized rates. S. 1504 would perpetuate—and expand—preferential access rights and subsidized rates that now benefit telecommunications and

cable companies, while failing to address critical infrastructure issues caused by increasing numbers of legitimate and illegitimate pole attachments. Not only would the proposed legislation exacerbate an already unfair cost burden on electric utilities and their customers, but it also could threaten the safety, integrity, and reliability of the electric distribution system.

As this Committee considers comprehensive legislation on broadband and other telecommunications matters, it should address important safety and reliability issues associated with the attachment of third-party facilities to utility-owned critical wireline infrastructure and should require all parties to pay a fair share of the costs of that infrastructure.

## **Background**

The nation's electric distribution systems—including poles, ducts, conduits, and rights-of-way—deliver power along millions of miles of lines to neighborhoods, businesses, and consumers, and are a key part of the nation's critical energy infrastructure. These facilities were designed and built originally to provide reliable and affordable electricity.

Responsibly sharing utility infrastructure avoids the wasteful duplication of facilities on public or private rights-of-way and reduces costs and other impacts on consumers. Electric and telephone utilities historically have shared their network facilities through mutual “joint use” agreements. Today, electric utilities own and operate the majority of the facilities to which telephone, cable, and other telecommunications companies attach their wires.

The Pole Attachment Act Amendment of 1978 (Section 224) limited the rates utilities could charge cable companies for their attachments to utility poles and other electric distribution facilities. In the 1996 Telecommunications Act, Congress amended Section 224 to require that electric utilities allow nondiscriminatory access at below-cost regulated rates for other entities (except incumbent local phone companies) seeking attachments to poles, ducts, conduits, and rights-of-way. The lowest regulated rates—which cover only a fraction of a fair share of the actual costs associated with establishing and maintaining the poles—are reserved for cable companies, which were seen at the time as “nascent service providers” that needed a subsidy. As a result, for example, an electric utility that averages \$80 per pole in annual maintenance and carrying charges is only permitted to recover from a cable TV company less than \$6 of the annual costs associated with owning the pole.

Legislation currently pending in Congress would expand the list of entities eligible for mandatory access and require the lowest subsidized cable rates under Section 224 to be available to all cable, telecommunications, and broadband providers. S. 1504 would expand Section 224 to benefit all “video service providers, regardless of the nature of the services provided,” not just cable television systems as under current law. The result would be a windfall, in the form of subsidized pole attachment rates equal to those already enjoyed by cable TV companies, for incumbent telecommunications companies that now pay negotiated rates for pole attachments.

Ironically, the communications industries that would benefit from preservation and expansion of federal pole attachment subsidies can hardly be described as “nascent” any longer. Virtually all of the major companies that would reap the benefits of

mandatory access and subsidized rates are today listed in the Fortune 500, are worth billions of dollars, and continue to grow through mega-mergers and acquisitions.

### **Critical Infrastructure Issues Need To Be Addressed**

Electric utility poles, ducts, and conduits are key components of the transmission and distribution network that provides our nation with reliable electric service. This network has long been recognized as a core infrastructure system critical to the nation's economy and homeland security. Public safety agencies, energy production and delivery companies, financial markets, telecommunications companies, and transportation, health care, water, and sanitation providers all depend on reliable electric and communications services.

Telephone, cable, and other telecommunications companies routinely attach their wires to electric distribution infrastructure. The rapid development of new communications technologies and the massive increase in demand for communications services, coupled with the numerous competitive entrants seeking to deploy those technologies and provide such services, have dramatically increased the number, size, and weight of communications facilities seeking to attach to the critical infrastructure. This universe of existing and potential pole attachments raises a number of issues.

- Pole attachments affect the structural integrity, safety, security, and reliability of electric distribution infrastructure.
- Pole attachments increase operation and maintenance costs for electric utilities and their customers.
- Pole attachments cause increased susceptibility to damage caused by ice and wind storms and other natural disasters.

- Pole attachments increase restoration times following natural disasters and other emergencies. For example, each additional wire and device attached or strung along a distribution network adds physical stresses (e.g., weight, wind loading, etc.) to the poles, resulting in an extra layer of complexity and risk from the standpoint of reliability, safety, and maintenance. When a pole is damaged by a storm or other catastrophic event, restoring service is more complex. This complexity is further multiplied when thousands of poles in a large utility system need to be replaced after a widespread natural disaster, such as a hurricane, ice storm, or earthquake.

The nation's electric utilities are fully capable of managing the shared use of their infrastructure to minimize these risks, but they cannot do so effectively in the current regulatory climate, which overemphasizes near-term deployment of telecommunications services to the detriment of the long-term safety, security, reliability, and integrity of the critical wireline infrastructure. For example, under present law and regulation, existing communications wires can be overlashed again and again with additional cables without an engineering evaluation of the ability of the poles to withstand the increased wind or ice loading and without any prior notice to the pole owner. When inventorying pole attachments, electric utilities routinely discover thousands, even tens of thousands, of attachments made to their poles without notice or authorization. These practices create a public safety issue, because the resulting pole loads may not be in compliance with good utility practice or the National Electrical Safety Code (NESC), which is the basic guideline on which most utility engineering standards are based.

Historically, promoting a rapid move to competition—not infrastructure protection—has been the primary policy goal of federal pole attachment legislation and regulation. Federal legislation enacted in 1978 and 1996 focused almost exclusively on access and subsidized rates for cable television and telecommunications companies. Safety, integrity, and reliability issues important to the protection of critical electric and telecommunications infrastructure to date have not been addressed adequately by Congress or the Federal Communications Commission (FCC).

Competition is an important goal, and indeed some electric utilities plan to provide a competitive “third link” to customers through the deployment of broadband over power line (BPL) technology. But without a safe and reliable electric utility infrastructure, which powers and supports cable and communications networks, even existing competition will be stymied. Pole attachment legislation must protect critical wireline infrastructure that supports both electric and communications services by providing for agreements between the parties; certification of the number of attachments; pre-attachment notification; and payment of “make-ready” (e.g., planning, engineering, and construction costs) and fair on-going maintenance costs.

### **Unfair Cost Subsidies Imposed on Electric Utilities and Their Customers**

The federal approach to pole attachment policy and regulation has focused on mandating access at rates far below fully allocated costs, in order to promote the deployment of new technologies and to foster competition. Unfortunately, that policy has not only undermined the safety, security, reliability, and integrity of the critical wireline infrastructure upon which both electric and communications service depends, but it has

unfairly forced electric utility customers to subsidize cable and telecommunications companies.

The cable industry can afford to pay its fair share for maintaining critical electric infrastructure, as can the other communications companies that make up the \$1 trillion telecommunications industry. Every user of these facilities should pay its full and fair share of the actual costs of building and safely maintaining the facilities.

Under current law, federally regulated pole attachment rates do not permit utilities to recover all of the costs actually related to supporting and managing such attachments. If pole attachment revenues are not sufficient to cover all costs, the difference is made up from rates paid by electric customers. The result is a subsidy borne by electric utility customers, including low-income customers who do not use the cable or new telecommunications products. Pole attachment revenues offset utility distribution system costs, and thus are not a source of profit for the utility.

The bottom line is that when the federal government requires pole attachment rates to be set far below market or even replacement rates, they become a subsidy for the attaching entities, at the expense of utility customers. To expand the FCC's class of entities entitled to subsidized pole attachment rates likely would lead to higher electric rates for electric utility customers in order to benefit large, highly profitable media and telecommunications conglomerates. This is unfair, and distorts critical infrastructure priorities by favoring broadband and video at the expense of electricity service.

Electric utilities also attach their equipment to telephone company poles, for which they pay a negotiated rate. Providing a lower subsidized rate to telecommunications providers would not only abrogate these longstanding reciprocal

agreements, but would create a significant disparity in the rates that electric utilities are charged to attach to telecommunications poles versus what telecommunications providers are charged for their attachments to electric utility poles.

Pole attachment legislation should eliminate—not expand—pole attachment subsidies to communications giants now borne by electric customers. The best way to prevent subsidies is to allow the parties to negotiate the rates, terms, and conditions for any attachments. Negotiated agreements, particularly joint use agreements between electric and telephone utilities, should not be abrogated. Regulated rates should apply only where existing agreements have expired according to their terms and the parties are unable to reach agreement, and should be phased in over a reasonable transition period to ensure that electric consumers are held harmless from rate increases. Regulated pole attachment rates should be technology-neutral so that all attaching entities pay the same rate regardless of the technology involved, and also must ensure that all costs of critical wireline infrastructure are shared proportionately among users. When allocating pole attachment costs, Congress should ensure that each entity pays for the space it uses. In addition, each paying entity (including the pole owner) should share equally in the cost of all other space on the pole (including space below ground level).

### **State Utility Commissions Should Be Allowed an Appropriate Role in Regulating Pole Attachments**

State commissions have decades of experience regulating retail electric service, including many rules and standards related to utility poles, ducts, and conduits. State commissions also regulate local telecommunications service.



Unlike nationwide telecommunications and cable services, pole attachments affect local facilities and raise local reliability issues. The safety, integrity, and reliability of this critical wireline infrastructure are largely dependent on local circumstances (e.g., geography, weather), and failures have local consequences (e.g., service interruptions, power outages).

State commissions are well positioned to oversee and regulate these attachments while balancing the electricity and telecommunications policy issues. And, states have proven they are capable of regulating pole attachments. Nineteen states already do so under current law.

States already are responsible for regulating the retail electric facilities subject to federal pole attachment rules—no federal agency has a similar role. From their long history of telecommunications and electric utility regulation, states are well prepared to handle all pole attachment issues and appropriately balance the interests of utility customers, telecommunications customers, and the public at large.

At the very least, states should be allowed to continue to regulate pole attachments and should be allowed a greater role in implementing and enforcing uniform pole attachment safety, reliability, engineering, and rate standards, and resolving disputes between utilities and attaching entities. If a state chooses not to regulate pole attachments, the FCC should regulate according to the uniform standards outlined above.

## **Conclusion**

As the threats to the structural integrity of critical wireline infrastructure grow, the electric utility industry believes that it is time to revise the current public policy regarding

pole attachments. Instead of forcing electric utility customers to subsidize the likes of Time Warner, Comcast, Cox, and the former Bell companies, Congress should:

- (1) Emphasize the protection of critical wireline infrastructure and public safety, and establish certain fundamental criteria for installing or modifying attachments to critical infrastructure.
- (2) Provide for an equitable sharing of the costs associated with the ownership of shared critical infrastructure among those who benefit from its use.
- (3) Set minimum notification, certification, and other requirements for gaining access to critical wireline infrastructure.
- (4) Allow continued and, where appropriate, expanded jurisdiction over the shared use of local critical infrastructure to the same state agencies that already regulate the safety, reliability, and cost of local electric and communications utility distribution systems and protect electric and communications consumers.

EEI and its member companies appreciate this opportunity to outline our concerns with the pole attachment provisions of S. 1504 and other proposed legislation. We look forward to working with the Members of the Committee on Commerce, Science and Transportation to address the issues we have raised.

### Attachment D -- Examples of Cost of Money for Consumer-owned Utilities

Solution #1						Solution #2	
		Cost	10%				
		Percentage of Equity	50%				
Examples:							
4bps/1% capital structure change based on UE 115							
Most Recent Authorized ROE (UE 179 PacifiCorp)							
Salem Electric		Cost	Percentage	wt. percent			
	Debt	0.00%	0%	0.00%	10-year Treasury adder		
	Equity	6.00%	100%	6.00%			
		<b>Total ROR</b>		<b>6.00%</b>	<b>Total ROR</b>		
					4.565%		
Premium over embedded debt (ROR - Debt Cost)				6.00%	2.000%		
					<b>6.56500%</b>		
Northern Wasco PUD (per Sue A.)		Cost	Percentage	wt. percent			
	Debt	5.25%	75%	3.94%	Debt Cost adder		
	Equity	9.00%	25%	2.25%			
		<b>Total ROR</b>		<b>6.19%</b>	<b>Total ROR</b>		
					5.250%		
Premium over embedded debt (ROR - Debt Cost)				0.94%	1.000%		
					<b>6.25000%</b>		
Central Lincoln (per Sue A.)		Cost	Percentage	wt. percent			
	Debt	5.00%	10%	0.50%	Debt Cost adder		
	Equity	6.40%	90%	5.76%			
		<b>Total ROR</b>		<b>6.26%</b>	<b>Total ROR</b>		
					5.000%		
Premium over embedded debt (ROR - Debt Cost)				1.26%	1.000%		
					<b>6.00000%</b>		
Oregon Trail Coop		Cost	Percentage	wt. percent			
	Debt	5.54%	47%	2.60%	Debt Cost adder		
	Equity	7.96%	51%	4.06%			
		<b>Total ROR</b>		<b>6.66%</b>	<b>Total ROR</b>		
					5.540%		
Premium over embedded debt (ROR - Debt Cost)				1.12%	1.000%		
					<b>6.54000%</b>		



# Oregon

Theodore R. Kulongoski, Governor

## Public Utility Commission

550 Capitol St NE, Suite 215

Mailing Address: PO Box 2148

Salem, OR 97308-2148

**Consumer Services**

1-800-522-2404

Local: (503) 378-6600

**Administrative Services**

(503) 373-7394

November 17, 2006

OREGON PUBLIC UTILITY COMMISSION  
ATTENTION: FILING CENTER  
PO BOX 2148  
SALEM OR 97308-2148

RE: **OPUC Docket Nos. AR 506 and AR 510** - In the Matters of Rulemaking to Amend and Adopt Rules in OAR 860 Divisions 24 and 28 Regarding Pole Attachment Use and Safety (AR 506) and Rulemaking to Amend Rules in OAR 860, Division 028 Relating to Sanctions for Attachments to Utility Poles and Facilities (AR 510).

Enclosed for filing in the above-captioned dockets is the Public Utility Commission Staff's Third Round of Comments in AR 506 & AR 510. As a courtesy, the interested persons identified on the Commission's service lists were also provided an electronic copy of these documents with the exception of Attachment C because of its file size. All interested persons who provided physical mailing addresses were mailed a complete copy of the comments and attachments.

*1st Diane Davis ddd*

Diane Davis  
Regulatory Operations Division  
Filing on Behalf of Public Utility Commission Staff  
(503) 378-4372

CERTIFICATE OF SERVICE

AR 506/AR 510

I certify that I have, this day, served *Staff's Third Round of Comments in AR 506 & AR 510, Dated November 17, 2006*, upon all participants of record in this proceeding by electronic mail pursuant to OAR 860-013-0070 and by mailing a copy properly addressed with first class postage prepaid to the participants as indicated on the attached service list.

Dated at Salem, Oregon, this 17th day of November, 2006.

*Diane Davis*

Diane Davis

On behalf of the Staff of the  
Public Utility Commission of Oregon

Attachment

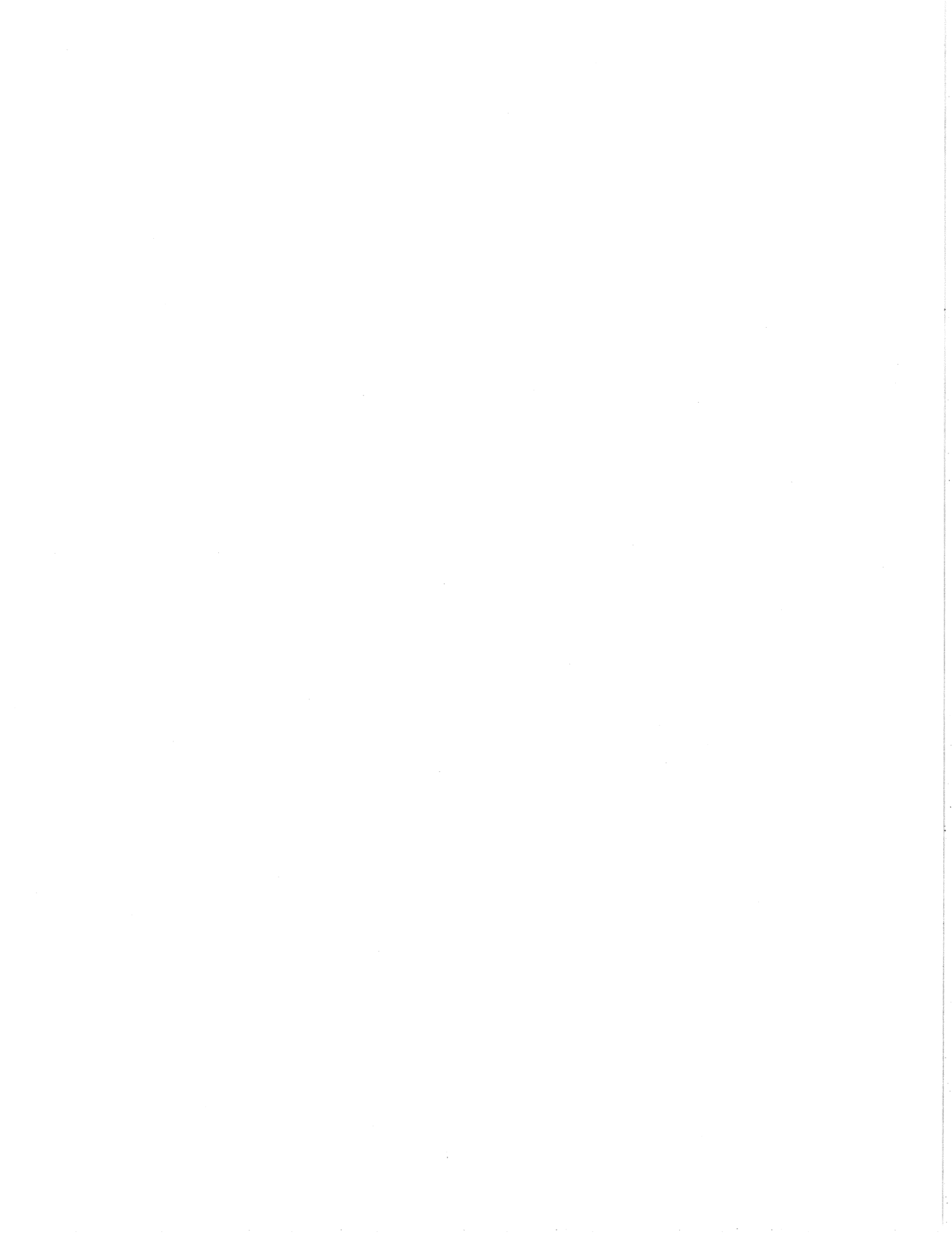

SUSAN BURKE  
VERIZON

EEmail [susan.burke@verizon.com](mailto:susan.burke@verizon.com)

PHIL CHARLTON  
ELECTRIC LIGHTWAVE

EEmail [pcharlton@eli-consulting.com](mailto:pcharlton@eli-consulting.com)

MATT COONS

EEmail [matt.coons@comspanusa.net](mailto:matt.coons@comspanusa.net)

DAWNA FARRELL  
COMCAST

EEmail [dawna\\_farrell@cable.comcast.com](mailto:dawna_farrell@cable.comcast.com)

LEE GUSTAVSON  
INTEGRA TELECOM OF OREGON INC

EEmail [lee.gustavson@integratelecom.com](mailto:lee.gustavson@integratelecom.com)

JEFF LIBERTY  
BEND BROADBAND

EEmail [jliberty@bendbroadband.net](mailto:jliberty@bendbroadband.net)

NANCY MARSTON  
COMCAST

EEmail [nancy\\_marston@cable.comcast.com](mailto:nancy_marston@cable.comcast.com)

SEBASTIAN MC CROHAN  
COMSPANUSA

EEmail [sebastian.mccrohan@comspanusa.net](mailto:sebastian.mccrohan@comspanusa.net)

ANDREW NENNINGER  
T-MOBILE

EEmail [andrew.nenninger@t-mobile.com](mailto:andrew.nenninger@t-mobile.com)

TERI OHTA  
T-MOBILE USA INC

EEmail [teri.ohta@t-mobile.com](mailto:teri.ohta@t-mobile.com)

KARLA WENZEL  
PORTLAND GENERAL ELECTRIC

EEmail [karla.wenzel@pgn.com](mailto:karla.wenzel@pgn.com)

SCOTT THOMPSON  
COLE RAYWID & BRAVERMAN LLP  
1919 PENNSYLVANIA AVE NW STE 200  
WASHINGTON DC 20006

EEmail [sthompson@crblaw.com](mailto:sthompson@crblaw.com)

JILL VALENSTEIN  
COLE, RAYWID, & BRAVERMAN, LLP  
1919 PENNSYLVANIA AVE NW, STE 200  
WASHINGTON DC 20006

EEmail [jvalenstein@crblaw.com](mailto:jvalenstein@crblaw.com)

WILLIAM K EDWARDS  
NATIONAL RURAL UTILITIES COOPERATIVE  
2001 COOPERATIVE WAY  
HERNDON VA 20171-2035

EEmail [bill.edwards@nrucfc.coop](mailto:bill.edwards@nrucfc.coop)

KEVIN L SAVILLE  
FRONTIER COMMUNICATIONS OF AMERICA INC  
2378 WILSHIRE BLVD.  
MOUND MN 55364

EEmail [ksaville@czn.com](mailto:ksaville@czn.com)

CATHERINE A MURRAY  
ESCHELON TELECOM OF OREGON INC  
730 SECOND AVE S STE 900  
MINNEAPOLIS MN 55402-2489

EEmail [camurray@eschelon.com](mailto:camurray@eschelon.com)

ROBERT DAVIDSON  
INTEGRA TELECOM OF OREGON INC  
1200 MINESOTA CTR 7760 FRANCE AVE  
BLOOMINGTON MN 55435

EEmail [robert.davidson@integratelecom.com](mailto:robert.davidson@integratelecom.com)

RICHARD STEWART  
VERIZON NORTHWEST INC  
600 HIDDEN RIDGE  
HQEO3J28  
IRVING TX 75038

EEmail [richard.stewart@verizon.com](mailto:richard.stewart@verizon.com)



FRANK X MCGOVERN  
QUALITY TELEPHONE INC  
PO BOX 7310  
DALLAS TX 75209-0310

EEmail [fmcgovern@qtelephone.com](mailto:fmcgovern@qtelephone.com)

THOMAS DIXON  
VERIZON CORPORATE SERVICES  
707 17TH STREET  
DENVER CO 80202

EEmail [thomas.f.dixon@verizon.com](mailto:thomas.f.dixon@verizon.com)

JEANNETTE C BOWMAN  
IDAHO POWER COMPANY  
PO BOX 70  
BOISE ID 83707

EEmail [jbowman@idahopower.com](mailto:jbowman@idahopower.com)

BRENT VAN PATTEN  
IDAHO POWER COMPANY  
PO BOX 70  
BOISE ID 83707

EEmail [bvanpatten@idahopower.com](mailto:bvanpatten@idahopower.com)

SANDRA HOLMS  
IDAHO POWER COMPANY  
PO BOX 70  
BOISE ID 83707-0070

EEmail [jbutler@idahopower.com](mailto:jbutler@idahopower.com)

BARTON L KLINE  
IDAHO POWER COMPANY  
PO BOX 70  
BOISE ID 83707-0070

EEmail [bkline@idahopower.com](mailto:bkline@idahopower.com)

LISA D NORDSTROM  
IDAHO POWER COMPANY  
PO BOX 70  
BOISE ID 83707-0070

EEmail [lnordstrom@idahopower.com](mailto:lnordstrom@idahopower.com)

RANDALL MILLER  
PACIFIC POWER & LIGHT  
1407 W N TEMPLE STE 220  
SALT LAKE CITY UT 84116

EEmail [randy.miller@pacificcorp.com](mailto:randy.miller@pacificcorp.com)

SUZANNE CURTIS  
CHARTER COMMUNICATIONS  
4031 VIA ORO AVE  
LONG BEACH CA 90810

EEmail [suzanne.curtis@chartercom.com](mailto:suzanne.curtis@chartercom.com)

KRISTIN L JACOBSON  
SPRINT NEXTEL  
201 MISSION ST STE 1400  
SAN FRANCISCO CA 94105

EEmail [kristin.l.jacobson@sprint.com](mailto:kristin.l.jacobson@sprint.com)

STEPHEN R CIESLEWICZ  
CN UTILITY CONSULTING  
PO BOX 746  
NOVATO CA 94948-0746

EEmail [steve@cutility.com](mailto:steve@cutility.com)

JOHN SULLIVAN  
OREGON JOINT USE ASSOCIATION  
2213 SW 153RD DR  
BEAVERTON OR 97006

EEmail [john.sullivan@pgn.com](mailto:john.sullivan@pgn.com)

RENEE WILLER  
VERIZON NORTHWEST INC  
20575 NW VON NEUMANN DR STE 150 MC OR030156  
HILLSBORO OR 97006

EEmail [renee.willer@verizon.com](mailto:renee.willer@verizon.com)

SCOTT WHEELER  
COMCAST PHONE OF OREGON LLC  
9605 SW NIMBUS AVE  
BEAVERTON OR 97008

EEmail [scott\\_wheeler2@cable.comcast.com](mailto:scott_wheeler2@cable.comcast.com)

WILLIAM C WOODS  
OREGON JOINT USE ASSOCIATION  
9605 SW NIMBUS AVE  
BEAVERTON OR 97008

EEmail [william\\_woods@cable.comcast.com](mailto:william_woods@cable.comcast.com)

KEENE C BASSO  
CLATSKANIE PUD  
PO BOX 216  
CLATSKANIE OR 97016

EEmail [kbasso@clatskaniepud.com](mailto:kbasso@clatskaniepud.com)

WILLIAM E HENDRICKS  
EMBARQ COMMUNICATIONS INC  
902 WASCO ST A0412  
HOOD RIVER OR 97031

EEmail [tre.hendricks@embarq.com](mailto:tre.hendricks@embarq.com)

NANCY JUDY  
EMBARQ COMMUNICATIONS INC  
902 WASCO ST A0412  
HOOD RIVER OR 97031

EEmail [nancy.judy@embarq.com](mailto:nancy.judy@embarq.com)

TOM MCGOWAN  
UNITED TELEPHONE COMPANY OF THE NORTHWEST  
902 WASCO ST  
HOOD RIVER OR 97031

EEmail [tom.a.mcgowan@sprint.com](mailto:tom.a.mcgowan@sprint.com)

BARBARA YOUNG  
UNITED TELEPHONE COMPANY OF THE  
NORTHWEST/EMBARQ  
902 WASCO ST - ORHDRA0412  
HOOD RIVER OR 97031-3105

EEmail [barbara.c.young@embarq.com](mailto:barbara.c.young@embarq.com)

BILL KIGGINS  
CLEAR CREEK MUTUAL TELEPHONE CO  
18238 S FISCHERS MILL RD  
OREGON CITY OR 97045-9612

EEmail [bkiggins@clearcreek.coop](mailto:bkiggins@clearcreek.coop)

SCOTT ROSENBALM  
MCMINNVILLE CITY OF WATER & LIGHT  
PO BOX 638  
MCMINNVILLE OR 97128-0638

EEmail [sgr@mc-power.com](mailto:sgr@mc-power.com)

WENDY L MARTIN  
ATER WYNNE LLP  
222 SW COLUMBIA ST - STE 1800  
PORTLAND OR 97201

EEmail [wlm@aterwynne.com](mailto:wlm@aterwynne.com)

SARAH K WALLACE  
DAVIS WRIGHT TREMAINE  
1300 SW FIFTH AVENUE  
SUITE 2300  
PORTLAND OR 97201

EEmail [sarahwallace@dwt.com](mailto:sarahwallace@dwt.com)

MARK P TRINCHERO  
DAVIS WRIGHT TREMAINE LLP  
1300 SW FIFTH AVE STE 2300  
PORTLAND OR 97201-5682

EEmail [marktrinchero@dwt.com](mailto:marktrinchero@dwt.com)

LISA F RACKNER  
ATER WYNNE LLP  
222 SW COLUMBIA ST STE 1800  
PORTLAND OR 97201-6618

EEmail [lfr@aterwynne.com](mailto:lfr@aterwynne.com)

JENNIFER BUSCH  
PORTLAND GENERAL ELECTRIC  
121 SW SALMON ST  
PORTLAND OR 97204

EEmail [jennifer.busch@pgn.com](mailto:jennifer.busch@pgn.com)

RANDALL DAHLGREN  
PORTLAND GENERAL ELECTRIC  
121 SW SALMON ST 1WTC 0702  
PORTLAND OR 97204

EEmail [randy.dahlgren@pgn.com](mailto:randy.dahlgren@pgn.com)

ALEX M DUARTE  
QWEST CORPORATION  
421 SW OAK ST STE 810  
PORTLAND OR 97204

EEmail [alex.duarte@qwest.com](mailto:alex.duarte@qwest.com)

RICHARD GRAY  
PORTLAND CITY OF - OFFICE OF TRANSPORTATION  
1120 SW 5TH AVE RM 800  
PORTLAND OR 97204

EEmail [richard.gray@pdxtrans.org](mailto:richard.gray@pdxtrans.org)

BARBARA HALLE  
PORTLAND GENERAL ELECTRIC  
121 SW SALMON ST 1 WTC-13  
PORTLAND OR 97204

EEmail [barbara.halle@pgn.com](mailto:barbara.halle@pgn.com)

RICHARD JOHNSON  
CITY OF PORTLAND  
1120 SW 5TH AVE RM 800  
PORTLAND OR 97204

EEmail [richard.johnson@pdxtrans.org](mailto:richard.johnson@pdxtrans.org)

DOUG KUNS  
PORTLAND GENERAL ELECTRIC  
121 SW SALMON ST  
PORTLAND OR 97204

EEmail [doug.kuns@pgn.com](mailto:doug.kuns@pgn.com)

KEVIN O'CONNOR  
TIME WARNER TELECOM  
520 SW 6TH AVE  
PORTLAND OR 97204

EEmail [kevin.oconnor@twtelecom.com](mailto:kevin.oconnor@twtelecom.com)

INARA K SCOTT  
PORTLAND GENERAL ELECTRIC  
121 SW SALMON ST  
PORTLAND OR 97204

EEmail [inara.scott@pgn.com](mailto:inara.scott@pgn.com)

ALEX TOOMAN  
PORTLAND GENERAL ELECTRIC  
121 SW SALMON ST  
PORTLAND OR 97204

EEmail [alex.tooman@pgn.com](mailto:alex.tooman@pgn.com)

JEFF KENT  
QWEST  
8021 SW CAPITOL HILL RD  
ROOM 180  
PORTLAND OR 97219

EEmail [jeffrey.kent@qwest.com](mailto:jeffrey.kent@qwest.com)

HEIDI CASWELL  
PACIFICORP  
825 NE MULTNOMAH ST  
PORTLAND OR 97232

EEmail [heide.caswell@pacificorp.com](mailto:heide.caswell@pacificorp.com)

CECE L COLEMAN  
PACIFIC POWER & LIGHT  
825 NE MULTNOMAH STE 800  
PORTLAND OR 97232

EEmail [cece.coleman@pacificorp.com](mailto:cece.coleman@pacificorp.com)

PETE CRAVEN  
PACIFICORP  
825 NE MULTNOMAH - STE 300  
PORTLAND OR 97232

EEmail [pete.craven@pacificorp.com](mailto:pete.craven@pacificorp.com)

BILL CUNNINGHAM  
PACIFICORP  
825 NE MULTNOMAH STE 1500  
PORTLAND OR 97232

EEmail [bill.cunningham@pacificorp.com](mailto:bill.cunningham@pacificorp.com)

WILLIAM EAQUINTO  
PACIFIC POWER & LIGHT  
825 NE MULTNOMAH - STE 1700  
PORTLAND OR 97232

EEmail [bill.eaquinto@pacificorp.com](mailto:bill.eaquinto@pacificorp.com)

COREY FITZGERALD  
PACIFIC POWER & LIGHT  
825 NE MULTNOMAH STE 800  
PORTLAND OR 97232

EEmail [corey.fitz-gerald@pacificcorp.com](mailto:corey.fitz-gerald@pacificcorp.com)

SHEILA HARRIS  
INTEGRA TELECOM OF OREGON INC  
1201 NE LLOYD BLVD, STE 500  
PORTLAND OR 97232

EEmail [sheila.harris@integratelecom.com](mailto:sheila.harris@integratelecom.com)

ANDREA L KELLY  
PACIFICORP DBA PACIFIC POWER & LIGHT  
825 NE MULTNOMAH ST STE 2000  
PORTLAND OR 97232

EEmail [andrea.kelly@pacificcorp.com](mailto:andrea.kelly@pacificcorp.com)

JAY NUSBAUM  
INTEGRA TELECOM OF OREGON INC  
1201 NE LLOYD BLVD - STE 500  
PORTLAND OR 97232

EEmail [jay.nusbaum@integratelecom.com](mailto:jay.nusbaum@integratelecom.com)

LAURA RAYPUSH  
PACIFICORP  
825 NE MULTNOMAH, STE 1700  
PORTLAND OR 97232

EEmail [laura.raypush@pacificcorp.com](mailto:laura.raypush@pacificcorp.com)

JIM DEASON  
ATTORNEY AT LAW  
1 SW COLUMBIA ST, SUITE 1600  
PORTLAND OR 97258-2014

EEmail [jimdeason@comcast.net](mailto:jimdeason@comcast.net)

SUSAN K ACKERMAN  
ATTORNEY  
PO BOX 10207  
PORTLAND OR 97296-0207

EEmail [susan.k.ackerman@comcast.net](mailto:susan.k.ackerman@comcast.net)

DOUG COOLEY  
CENTURYTEL OF OREGON INC  
707 13TH ST STE 280  
SALEM OR 97301

EEmail [doug.cooley@centurytel.com](mailto:doug.cooley@centurytel.com)

DON GODARD  
OREGON PUD ASSOCIATION  
727 CENTER ST NE - STE 305  
SALEM OR 97301

EEmail [dgodard@opuda.org](mailto:dgodard@opuda.org)

GENOA INGRAM  
OREGON JOINT USE ASSOCIATION  
1286 COURT ST NE  
SALEM OR 97301

EEmail [genoa@westernadvocates.com](mailto:genoa@westernadvocates.com)

SANDRA FLICKER  
OREGON RURAL ELECTRIC COOPERATIVE ASSN  
707 13TH ST SE STE 200  
SALEM OR 97301-4005

EEmail [sflicker@oreca.org](mailto:sflicker@oreca.org)

BRANT WOLF  
OREGON TELECOMMUNICATIONS ASSN  
707 13TH ST SE STE 280  
SALEM OR 97301-4036

EEmail [bwolf@ota-telecom.org](mailto:bwolf@ota-telecom.org)

MICHAEL T WEIRICH  
DEPARTMENT OF JUSTICE  
REGULATED UTILITY & BUSINESS SECTION  
1162 COURT ST NE  
SALEM OR 97301-4096

EEmail [michael.weirich@doj.state.or.us](mailto:michael.weirich@doj.state.or.us)

MICHAEL DEWEY  
OREGON CABLE AND TELECOMMUNICATIONS  
ASSOCIATION  
1249 COMMERCIAL ST SE  
SALEM OR 97302

EEmail [mdewey@oregoncable.com](mailto:mdewey@oregoncable.com)



ROGER KUHLMAN  
633 7TH ST NW  
SALEM OR 97304

EEmail [kuhlman@salemelectric.com](mailto:kuhlman@salemelectric.com)

DAVID P VAN BOSSUYT  
PORTLAND GENERAL ELECTRIC  
4245 KALE ST NE  
SALEM OR 97305

EEmail [dave.vanbossuyt@pgn.com](mailto:dave.vanbossuyt@pgn.com)

ANDREA FOGUE  
LEAGUE OF OREGON CITIES  
PO BOX 928  
1201 COURT ST NE STE 200  
SALEM OR 97308

EEmail [afogue@orcities.org](mailto:afogue@orcities.org)

TOM O'CONNOR  
OREGON MUNICIPAL ELECTRIC UTILITIES ASSOC  
PO BOX 928  
SALEM OR 97308-0928

EEmail [toconnor@teleport.com](mailto:toconnor@teleport.com)

JERRY MURRAY  
PUBLIC UTILITY COMMISSION  
PO BOX 2148  
SALEM OR 97308-2148

EEmail [jerry.murray@state.or.us](mailto:jerry.murray@state.or.us)

GARY PUTNAM  
PUBLIC UTILITY COMMISSION  
PO BOX 2148  
SALEM OR 97308-2148

EEmail [gary.putnam@state.or.us](mailto:gary.putnam@state.or.us)

JOHN WALLACE  
PUBLIC UTILITY COMMISSION  
PO BOX 2148  
SALEM OR 97308-2148

EEmail [john.wallace@state.or.us](mailto:john.wallace@state.or.us)

THE HONORABLE ROBERT ACKERMAN  
OREGON HOUSE OF REPRESENTATIVES  
900 COURT ST NE RM H-389  
SALEM OR 97310

JIM MARQUIS  
PACIFICORP  
830 OLD SALEM RD  
ALBANY OR 97321

EEmail [james.l.marquis@pacificorp.com](mailto:james.l.marquis@pacificorp.com)

J WHITE  
MONMOUTH CITY OF  
151 W MAIN ST  
MONMOUTH OR 97361

EEmail [jwhite@ci.monmouth.or.us](mailto:jwhite@ci.monmouth.or.us)

DAVE WILDMAN  
MONMOUTH CITY OF  
401 N HOGAN RD  
MONMOUTH OR 97361

EEmail [dwildman@ci.monmouth.or.us](mailto:dwildman@ci.monmouth.or.us)

DENISE ESTEP  
CENTRAL LINCOLN PUD  
PO BOX 1126  
NEWPORT OR 97365

EEmail [destep@cencoast.com](mailto:destep@cencoast.com)

MICHAEL L WILSON  
CENTRAL LINCOLN PUD  
2129 N COAST HWY  
NEWPORT OR 97365-0090

EEmail [mwilson@cencoast.com](mailto:mwilson@cencoast.com)

GENERAL MANAGER  
PIONEER TELEPHONE COOPERATIVE  
1304 MAIN ST PO BOX 631  
PHILOMATH OR 97370

STUART SLOAN  
CONSUMER POWER INC  
PO BOX 1180  
PHILOMATH OR 97370

EEmail [stuarts@cpi.coop](mailto:stuarts@cpi.coop)

CHRISTY MONSON  
SPEER, HOYT, JONES, FEINMAN, ET AL  
975 OAK STREET, SUITE 700  
EUGENE OR 97401

EEmail [christy@speerhoyt.com](mailto:christy@speerhoyt.com)

CRAIG ANDRUS  
EMERALD PUD  
33733 SEAVEY LOOP RD  
EUGENE OR 97405-9614

EEmail [craig.andrus@epud.org](mailto:craig.andrus@epud.org)

MARK OBERLE  
EUGENE WATER & ELECTRIC BOARD (EWEB)  
PO BOX 10148  
EUGENE OR 97440

EEmail [mark.oberle@eweb.eugene.or.us](mailto:mark.oberle@eweb.eugene.or.us)

SCOTT ADAMS  
COOS-CURRY ELECTRIC COOPERATIVE INC  
PO BOX 1268  
PORT ORFORD OR 97465

EEmail [scotta@cooscurryelectric.com](mailto:scotta@cooscurryelectric.com)

LINDA L SPURGEON  
COOS CURRY ELECTRIC COOPERATIVE  
PO BOX 1268  
PORT ORFORD OR 97465

EEmail [spurgeon@cooscurryelectric.com](mailto:spurgeon@cooscurryelectric.com)

MARTY PATROVSKY  
WANTEL INC  
1016 SE OAK AVE  
ROSEBURG OR 97470

EEmail [marty.patrovsky@comspanusa.net](mailto:marty.patrovsky@comspanusa.net)

TAMARA JOHNSON  
SPRINGFIELD UTILITY BOARD  
PO BOX 300  
SPRINGFIELD OR 97477

EEmail [tamaraj@subutil.com](mailto:tamaraj@subutil.com)

RICHARD W RYAN  
HUNTER COMMUNICATIONS INC  
801 ENTERPRISE DR STE 101  
CENTRAL POINT OR 97502

EEmail [rryan@coreds.net](mailto:rryan@coreds.net)

RONALD W JONES  
IBEW LOCAL 659  
4480 ROGUE VALLEY HWY #3  
CENTRAL POINT OR 97502-1695

EEmail [ronjones@ibew659.org](mailto:ronjones@ibew659.org)

SCOTT JOHNSON  
ASHLAND CITY OF  
90 NORTH MOUNTAIN AVE  
ASHLAND OR 97520

EEmail [johnsons@ashland.or.us](mailto:johnsons@ashland.or.us)

ANTHONY BAILEY  
OREGON TRAIL ELECTRIC COOPERATIVE  
PO BOX 226  
BAKER CITY OR 97814

EEmail [abailey@otecc.com](mailto:abailey@otecc.com)

PRIORITYONE TELECOMMUNICATIONS INC  
PO BOX 758  
LA GRANDE OR 97850-6462

EEmail [kmutch@p1tel.com](mailto:kmutch@p1tel.com)

EUGENE A FRY  
MILLENNIUM DIGITAL MEDIA  
3633 136TH PL SE #107  
BELLEVUE WA 98006

EEmail [gfry@mdm.net](mailto:gfry@mdm.net)

CINDY MANHEIM  
CINGULAR WIRELESS  
PO BOX 97061  
REDMOND WA 98073

Email [cindy.manheim@cingular.com](mailto:cindy.manheim@cingular.com)

BROOKS HARLOW  
MILLER NASH LLP  
601 UNION ST STE 4400  
SEATTLE WA 98101-2352

Email [brooks.harlow@millernash.com](mailto:brooks.harlow@millernash.com)

BRIAN THOMAS  
TIME WARNER TELECOM OF OREGON LLC  
223 TAYLOR AVE N  
SEATTLE WA 98109-5017

Email [brian.thomas@twtelecom.com](mailto:brian.thomas@twtelecom.com)

RICHARD J BUSCH  
GRAHAM & DUNN PC  
PIER 70  
2801 ALASKAN WAY STE 300  
SEATTLE WA 98121-1128

Email [rbusch@grahamdunn.com](mailto:rbusch@grahamdunn.com)

GARY LEE  
CHARTER COMMUNICATIONS CORP  
521 NE 136TH AV  
VANCOUVER WA 98684

Email [glee@chartercom.com](mailto:glee@chartercom.com)

STEVEN LINDSAY  
VERIZON  
C/O SUSAN BURKE  
1800 41ST ST  
EVERETT WA 98201

Email [steve.lindsay@verizon.com](mailto:steve.lindsay@verizon.com)

LAWRENCE REICHMAN  
PERKINS COIE LLP  
1120 NW COUCH ST - 10 FL  
PORTLAND OR 97209-4128

Email [lreichman@perkinscoie.com](mailto:lreichman@perkinscoie.com)

