

**KENNETH KAUFMANN, ATTORNEY AT LAW**

1785 Willamette Falls Drive • Suite 5  
West Linn, OR 97068

office (503) 230-7715  
fax (503) 972-2921

---

Kenneth E. Kaufmann  
Ken@KaufmannLaw  
(503) 595-1867

April 17, 2024

***Via Electronic Mail and USPS Priority Mail***

Filing Center  
Public Utility Commission of Oregon  
P.O. Box 1088  
Salem, OR 97308-1088  
puc.filingcenter@puc.oregon.gov

**Re: UM 2322 Pilot Rock Solar 1 LLC et al's First Amended Complaint**

Attention Filing Center:

Attached for filing in the above-captioned docket is an electronic version of *Pilot Rock Solar 1 LLC et al's First Amended Complaint*. This filing replaces the original *Complaint* of April 4, 2014 in its entirety.

Thank you in advance for your assistance.

Sincerely,



Ken Kaufmann  
Attorney for Complainants

Attach.

CERTIFICATE OF SERVICE

In accordance with OAR 860-082-0085 and OAR 860-001-0180; I HEREBY CERTIFY that on April 17, 2024, I caused to be served a full and exact copy of the foregoing **Pilot Rock Solar 1 LLC et al's First Amended Complaint** in OPUC Docket UM 2322 upon the parties shown below via:

- USPS Priority Mail with postage prepaid, deposited in the US Mail at Tigard, Oregon
- hand delivery
- facsimile transmission
- overnight delivery
- e-mail
- OPUC EFILING SYSTEM, in accordance with OAR 860-001-0180.

Kristopher Bremer Pacific Power 825 NE Multnomah, Suite 800 Portland, OR 97232 Kristopher.Bremer@PacifiCorp.com  (OPUC eFiling system)	Filing Center Public Utility Commission of Oregon PO Box 1088 Salem, OR 97308-1088 PUC.FilingCenter@puc.oregon.gov  (e-mail and USPS Priority Mail)
Matthew Loftus Pacific Power 825 NE Multnomah, Suite 1600 Portland, OR 97232 Matthew.Loftus@PacifiCorp.com  (OPUC eFiling system)	Pacific Power 825 NE Multnomah, Suite 2000 Portland, OR 97232 oregondockets@PacifiCorp.com  (OPUC eFiling system)
John Lowe Renewable Energy Coalition PO Box 25576 Portland, OR 97298 johnl@recoalition.com  (OPUC eFiling system)	Mike McArthur Community Renewable Energy Association 83350 Foss Ln Wasco, OR 97065 mwm@crearenewables.org  (OPUC eFiling system)
Matthew McVee Pacific Power 825 NE Multnomah Portland, OR 97232 matthew.mcvee@pacificorp.com  (OPUC eFiling system)	Irion A. Sanger Sanger Law, PC 4031 SE Hawthorne Blvd Portland, OR 97214 irion@sanger-law.com  (OPUC eFiling system)

Ken Kaufmann, Attorney at Law  
1785 Willamette Falls Drive, Suite 5  
West Linn, OR 97068  
503/230-7715  
ken@kaufmann.law

Daniel Hale Sunthurst Energy, LLC PO Box 549 Stanfield, OR 97875 daniel@sunthurstenergy.com  (OPUC eFiling system)	Joni L. Sliger Sanger Law, PC 4031 SE Hawthorne Blvd Portland, OR 97214 joni@sanger-law.com  (OPUC eFiling system)
Nancy Kerns City of Pendleton nancy.kerns@pendletonor.gov  (OPUC eFiling system)	Teri Bacus City of Pilot Rock teri.bacus@cityofpilotrock.org  (OPUC eFiling system)

Dated: April 17, 2024  
s/ Kenneth E Kaufmann  
Kenneth E Kaufmann  
Attorney for Complainants  
OSB# 982672

Ken Kaufmann, Attorney at Law  
1785 Willamette Falls Drive, Suite 5  
West Linn, OR 97068  
503/230-7715  
ken@kaufmann.law

BEFORE THE PUBLIC UTILITY COMMISSION OF OREGON

DOCKET NO. UM 2322

**PILOT ROCK SOLAR 1, LLC**, an Oregon limited liability company; **PILOT ROCK SOLAR 2, LLC**, an Oregon limited liability company; **TUTUILLA SOLAR, LLC**, an Oregon limited liability company; **BUCKAROO SOLAR 1, LLC**, an Oregon limited liability company; and **BUCKAROO SOLAR 2, LLC**; an Oregon limited liability company;

Complainants,

v.

PACIFICORP d/b/a Pacific Power, an Oregon corporation,

Defendant

FIRST AMENDED COMPLAINT

Expedited Review Requested

**I. INTRODUCTION**

Complainants are five<sup>1</sup> Pre-Certified Oregon Community Solar projects (“CSPs”) seeking to interconnect to Pacific Power (“PacifiCorp”). All five projects executed interconnection agreements (“IAs”) with PacifiCorp, and share common issues regarding PacifiCorp’s performance thereof. Complainants, who are in various stages of project construction<sup>2</sup>, expect their interconnections to PacifiCorp will not be completed in a reasonable time and upon reasonable terms if the Commission does not grant their

<sup>1</sup> Pilot Rock Solar 1, LLC (1.98 MW, Q0666); Pilot Rock Solar 2, LLC (2.99 MW, Q1045); Tutuilla Solar, LLC (1.56 MW, OCS 024); Buckaroo 1 Solar, LLC (2.4 MW, OCS 062); Buckaroo 2 Solar, LLC (2.99 MW, OCS 063), together the “Sunthurst CSPs”. The Sunthurst CSPs are Qualifying Facilities under the Public Utility Regulatory Policies Act (“PURPA”), and belong to developer Sunthurst Energy, LLC.

<sup>2</sup> See photos of work in progress, in **Attachment A**.

requested relief.<sup>3</sup> Complainants seek modification of their IAs pursuant to Section 8.10<sup>4</sup>, which entitles either party to seek modification of the agreement by the Commission, and pursuant to the implied covenant of good faith. Complainants also seeks modification of the PPAs for Pilot Rock Solar 1, Pilot Rock Solar 2 and Buckaroo 1 Projects, consistent with the implied covenant of good faith. Several of Complainants' issues are common to other CSPs in PacifiCorp territory.

## II. EXECUTIVE SUMMARY

**A. Complainants and their Complaint.** Complainants are single purpose limited liability companies ("LLC"), each named after the pre-Certified Oregon Community Solar Project ("CSPs") they own and control. The five project LLCs are: Pilot Rock Solar 1, LLC ("Pilot Rock 1"); Pilot Rock Solar 2, LLC ("Pilot Rock 2"); Tutuilla Solar, LLC ("Tutuilla"); Buckaroo Solar 1, LLC ("Buckaroo 1"); and Buckaroo Solar 2, LLC ("Buckaroo 2")(together the "Sunthurst Projects" or "Complainants"). All five Projects are owned and managed by Sunthurst Energy, LLC ("Sunthurst"), a small, family-owned developer of renewable energy headquartered in Oregon. All five Projects are located in PacifiCorp service territory and have one or more contracts with PacifiCorp.

As of April 12, Pilot Rock 1 is 40% constructed, Pilot Rock 2 is 10% constructed, and Buckaroo 1 is 3% constructed. The other two projects have not yet commenced

---

<sup>3</sup> PacifiCorp previously threatened to terminate Complainants' IAs but, after the Commission granted Complainants interim relief on April 5, has agreed not to terminate for the pendency of this proceeding, thereby mooted the need for further action on Complainants' April 4 motion for interim relief.

<sup>4</sup> The IAs and amendments are attached to this Complaint as **Attachment B**.

construction. None of Complainants' Projects can reasonably proceed much further until contractual issues with PacifiCorp are resolved.

The Commission has set an initial target size for the Community Solar Program of approximately 160 MW.<sup>5</sup> Of the 29.1 MW of CSPs that have achieved operation, only 8% (2.4 MW) are sited in PacifiCorp territory.<sup>6</sup> The near-total lack of CSPs in PacifiCorp territory begs the question: **Why?** Complainants' experience, as explained below, shows the inequities in PacifiCorp's execution of the Community Solar Program that together have made Community Solar development in PacifiCorp territory next to impossible.

## **B. Obstacles PacifiCorp Poses to Community Solar.**

**1. Unnecessary Direct Transfer Trip.** PacifiCorp is requiring Direct Transfer Trip<sup>7</sup>, or "DTT", using high side breakers, at each of Complainants' five interconnections. The world has changed since PacifiCorp concluded DTT is necessary in at least three material respects.

First, the Commission recently changed its rules to require PacifiCorp to use input data that accurately reflects export capacity, unlike its historic practice of using DC nameplate capacity, which does not accurately reflect export capacity of solar facilities.<sup>8</sup>

---

<sup>5</sup> *E.g., In re Community Solar Program Implementation*, Docket No. UM 1930, Order No. 19-392 at 2 (Nov. 8, 2019).

<sup>6</sup> Docket No. UM 1930, Staff Report for the January 23, 2024 Public Meeting (Item No. RA1) at 3 (Jan. 17, 2024). Staff reported these numbers as of January 1, 2024.

<sup>7</sup> DTT is one of several available means of quickly separating generation from the system when utility protection equipment detects an overcurrent fault sufficient to open the utility source breaker or line recloser.

<sup>8</sup> See Order No. 24-068, Appendix A at 14-15. ("Current interconnection rule requirements reference direct current (DC) nameplate capacity. As a part of modernizing the rule requirements, these items will be changed to also reflect export capacity value, which is

The obvious implication of the Commission’s action is that past studies using DC nameplate capacity data cannot be relied upon.

Second, there is growing industry recognition that inverter-based generation does not cause harmful effects on feeders where there are no rotating generators on the same feeder. For example, the Unintentional Islanding (“UI”) Working Group, established by the California Public Utilities Commission to study distribution system level island formation and recommend solutions, recently found that “[UI] is only a concern when a machine-based generator is present on the circuit and is not an issue when only certified-inverter-based generation is present.”<sup>9</sup>

Third, Oregon’s recent adoption of IEEE 1547-2018 standards for interconnections, in some cases, allow DTT to be installed on the low-side of the facility’s step-up transformer, which can eliminate the need for costly high-side breakers.

Each of these material changes apply to the Complainants’ Projects: 1) Complainants’ Projects presumably were studied using DC nameplate data; 2) Complainants’ Projects will be located on feeders that do not have any rotating generators; and 3) Complainants’ Projects do not require high side DTT under the

---

typically measured at the inverter as an alternating current (AC) nameplate rating. Utilities will need to update their records, or historic legacy data for existing net metering and small generator projects and update their data collection approach to reflect this change. ... Staff further requests that the utilities ... begin relying on updated information in any interconnection review process.”); see also Order No. 24-068 at 3-4 (ordering PacifiCorp to “use and share updated information as it becomes available”).

<sup>9</sup> See, e.g. “Unintentional Islanding Working Group (UIWG): Final Report”, by Gridworks et al. (December 8, 2023), <https://gridworks.org/wp-content/uploads/2023/12/Final-UIWG-Report-12082023.pdf> (website last accessed April 16, 2024).

requirements of IEEE 1547-2018. The changed conditions, above, warrant review of, and amendment to, the DTT requirements in Complainants' IAs.

The Small Generator Interconnection rules require PacifiCorp to identify the “adverse system impacts”<sup>10</sup> that an interconnection will cause, “determine what actions or upgrades are required to mitigate those impacts” and require the interconnection customer to “pay the reasonable costs” of mitigating those impacts.<sup>11</sup> The theoretical adverse impact PacifiCorp seeks to mitigate with DTT is UI during system fault.<sup>12</sup> Although UI has been documented where there is a rotating generator on the circuit, Complainants are unaware of the utilities proffering any evidence of a single instance of UI on any circuit where the only generation is inverter based solar generation.

There is good reason for the lack of UI with inverted based solar generation: compared to rotating generators, inverters function as current-sources rather than as voltage-sources. This means that inverters offer built-in protection to quickly separate during abnormal voltage, current, and/or frequency events. Further, the utility-grade protective relay PacifiCorp requires at each facility has its own capabilities to detect such abnormal conditions. Inverters coupled with the utility breaker relay already provide redundant protection, even without DTT. None of Complainants' Projects will connect to

---

<sup>10</sup> PacifiCorp's change to AC export capability in its system models could also result in PacifiCorp finding that DTT is not required at one or more of Complainants' Projects, because the need for DTT is a function of the maximum output of the DER.

<sup>11</sup> Order No. 22-134 at 7 (citing OAR 860-082-0035(4)).

<sup>12</sup> Islanding in and of itself is not harmful, the western grid operates as a large island, it is the possible abnormal voltages that might occur during such an island that can possibly, if they occur, cause equipment damage. It is the presence of equipment that can create abnormal damaging voltages that creates the adverse impact during an unintentional island.



feeders where rotating generators (wind, hydro, turbine, etc.) are present. Therefore, PacifiCorp's requirement of DTT, as a tertiary level of protection for a theoretical adverse effect that has never been observed in the real world, is unreasonable when applied to Complainants. The Commission should amend Complainants' IAs to remove the unnecessary DTT requirement and its costs.

In the alternative, if the Commission concludes the theoretical adverse system impacts identified by PacifiCorp warrant mitigation through DTT, then PacifiCorp's specification of DTT at Complainant's Projects using high side breakers is unreasonable. Since PacifiCorp studied the Projects, Oregon has adopted IEEE 1547-2018.<sup>13</sup> That standard, applied to Complainants' Projects, permits the installation of the breaker used for DTT to be on the low side, whereas the previous standard did not. Where there is no requirement for a high-side breaker, PacifiCorp reasonably must allow the Projects to use low-side breakers, which cost substantially less to install and operate, or else not charge Complainants the incremental extra cost of high side DTT. Under this alternative, then, the Commission should amend Complainants' IAs to reduce the cost of DTT by specifying the use of low-side breakers.

## **2. Increasing Interconnection Timelines and Accelerated Milestone**

**Payments.** When Complainants asked PacifiCorp to postpone the milestone payments in

---

<sup>13</sup> Order No. 24-068, Appendix A at 4. The updated standard provides enhanced transient overvoltage protection requirements which eliminate the requirement for grounding-style main or supplemental transformers, where a Project will use inverters that comply with Section 7.4 of the updated IEEE 1547. Elimination of the high-voltage grounding transformer requirement eliminates the need for the utility breaker to be placed on the high-voltage (grid) side of the transformer.

their IAs, in May 2023, PacifiCorp made unrequested and unreasonable changes to all the milestones and construction schedules. PacifiCorp increased its time to construct the Pilot Rock 1, Pilot Rock 2 and Tutuilla interconnections (start to finish), from *9 months* to approximately *2 years and 5 months*. And it accelerated the deadline for receipt of final milestone payments for Pilot Rock 1 Solar, Pilot Rock 2 and Tutuilla interconnections, from *3 months* prior to the scheduled Commercial Operation Date (“COD”) to *1 year and 3 months* prior to COD. Complainants signed the amendments because, based on their past history with PacifiCorp of modifying the IA timelines on many occasions, they reasonably believed the CODs in the amendments were placeholders that could be modified, within reason, when Complainants secured project financing. But PacifiCorp did not agree to reasonable modifications as it had done before. The interconnection timelines and accelerated milestone payments in the current IAs for Pilot Rock 1, Pilot Rock 2 and Tutuilla add approximately \$12,000/month per Project to Complainants’ costs compared to the timelines in the unamended IAs.

3. **Refusal to accept payment after the COD.** Like all CSPs, Complainants are qualifying facilities with specific rights under Oregon law and pursuant to Commission rules. Under OAR 860-029-0060(2) PacifiCorp is authorized to be “reimbursed” its reasonable interconnection costs with interest,;

The public utility will be *reimbursed* by the qualifying facility for any reasonable interconnection costs including costs of financing at an interest rate no greater than the effective rate of the public utility’s last senior securities issuance at the time of the contract with the qualifying facility. Such

reimbursement may be over any agreed period not greater than one-half the length of any contract between the public utility and the qualifying facility when the contract is for a period greater than two years; otherwise, reimbursement will be made over a one-year period.<sup>14</sup>

Despite this rule, PacifiCorp is demanding payment far in advance of Complainants' estimated CODs. Deferring all or part of Complainants' payments for interconnection facilities until after Commercial Operation would help Complainants complete their Projects. Complainants, in partnership with City of Pendleton, City of Pilot Rock, and the Confederated Tribes of the Umatilla Indian Reservation ("CTUIR"), applied and received C-REP grants for several of their Projects<sup>15</sup> and wish to use their proceeds from their C-REP grants to help pay the interconnection costs. However, the State of Oregon withholds at least 70% of the grant money until the grantee's project achieves operation.<sup>16</sup> PacifiCorp refused Complainants' request it accept reimbursement of interconnection costs shortly after Commercial Operation, thereby depriving Complainants' ability to fully utilize their C-REP grant money. The Commission should amend Complainants' IAs to be consistent with OAR 860-029-0060(2) and allow all or most payment after commercial operation and receipt of their grant funds.

---

<sup>14</sup> *Id.* (emphasis added).

<sup>15</sup> The Projects with C-REP grant awards, and their partners, are:

- Buckaroo 1, in partnership with City of Pendleton: \$850,000 total grant.
- Tutuilla, in Partnership with the CTUIR: \$1,000,000 total grant.
- Pilot Rock 2, in Partnership with City of Pilot Rock: \$1,000,000 total grant.

<sup>16</sup> See Sample *Performance Agreement*, Section 7(a), at:  
<https://www.oregon.gov/energy/Incentives/Documents/Sample-CREP-PA-Template-Construction-Renewable.pdf>

4. **Withholding Power Purchase Agreements.** Sunthurst requested Community Solar Power Purchase Agreements (“PPAs”) from PacifiCorp for Pilot Rock 1 and Tutuilla on May 5, 2022. Both projects were pre-certified CSPs before that time,<sup>17</sup> and were entitled to CSP PPAs consistent with OAR 860-088-0140(1)(a). PacifiCorp C&T, the group processing the PPAs, withheld draft PPAs and final PPAs from these two Complainants until Complainants proved that IA assignments (to Complainants from their parent, Sunthurst) were finalized. The Commission has barred PacifiCorp from holding up qualifying facility PPAs for interconnection issues on multiple occasions.<sup>18</sup> Tying Complainants’ PPA negotiations to the status of its IAs delayed the Pilot Rock 1 and Tutuilla PPAs by approximately 90 days during a period of rapidly rising lending rates. This unlawful and unnecessary harm by PacifiCorp is another independent justification for the Commission to amend the IA and allow Complainants to pay all or most of their interconnection costs after achieving commercial operations and receiving grant funds.

5. **Change Line Extension at Pilot Rock 1 and Pilot Rock 2.** In the time since the IAs were signed, substantial changes have occurred at the 440-acre Industrial Park where Pilot Rock 1 and Pilot Rock 2 are sited, making the current interconnection plan for Pilot Rock 1 and Pilot Rock 2 obsolete. City of Pilot Rock recently begun actively marketing its Industrial Park statewide using its municipal website and Business

---

<sup>17</sup> UM 1930, Order No. 20-078, Order No. 20-439.

<sup>18</sup> *See*, Order No 07-360 at 8 (instructing PacifiCorp to remove from its Schedule 38 the requirement that QF obtain a completed interconnection study before receiving a draft PPA); Order No. 21-097 at 7-8 (“[a]ccordingly, we expect PacifiCorp to continue with its new policy of offering draft PPAs prior to the completion of interconnection studies for non-standard contracts”).

Oregon—the state’s economic development agency.<sup>19</sup> Given the City’s development plans for the Industrial Park, PacifiCorp will need to extend service into the Industrial Park soon. In fact, extending the service will accelerate development of the remaining Industrial Park properties.<sup>20</sup>

The Pilot Rock 1 and Pilot Rock 2 Projects, when completed, will be approximately 2,000 feet due north of PacifiCorp’s existing service. Their IAs specify Pilot Rock 1 and Pilot Rock 2 will build and own approximately 1,800 feet of a new, 12.5 kV, line, and the last approximately 200 feet (3 poles) will be built and owned by PacifiCorp (“Project line extension”). The Project line extension will be constructed within an 80-foot utility corridor, which must also accommodate all future utilities serving the Industrial Park.<sup>21</sup> The Project line extension would not serve PacifiCorp customers, and would lie between the future PacifiCorp service and the county road. However, a second pole line would be unnecessary if PacifiCorp built the line extension to the Industrial Park first, and agreed to amend the Pilot Rock Projects’ Point of Interconnection, moving it 2,000 feet north, Pilot Rock 1, Pilot Rock 2. This would allow all future Industrial Park tenants to share use of the new PacifiCorp line extension. Such arrangement is City of Pilot Rock’s strongly preferred solution, and the best solution, because it minimizes duplication of facilities, thereby minimizing use of land and resources, and overall cost. City of Pilot Rock, City of

---

<sup>19</sup> See November 30, 2023 letter from City of Pilot Rock to PacifiCorp, **Attachment C**.

<sup>20</sup> City of Pendleton, who shares an interest in development of the Industrial Park, agrees with City of Pilot Rock, that electric service is one of the most important factors enabling buildout of the Industrial Park. See December 1, 2023 letter from City of Pendleton to PacifiCorp, **Attachment D**.

<sup>21</sup> Maps showing the Industrial Park and the utility corridor are attached as **Attachment E**.

Pendleton, and the Pilot Rock Projects have all asked PacifiCorp to implement a one pole-line solution for service to the Industrial Park and the Pilot Rock Projects, but PacifiCorp has not responded.

It is unreasonable to require Pilot Rock 1 and Pilot Rock 2 to build a duplicate line extension alongside PacifiCorp's, where PacifiCorp will have to extend service to the Industrial Park regardless of the Pilot Rock Projects. The Commission should amend the point of interconnection and line extension requirement in Complainants' IAs to achieve a more efficient and cost-effective solution for Complainants and other ratepayers.

6. **Buckaroo 1 Battery Energy Storage.** Buckaroo 1 desires to add behind-the-meter battery storage to its Project. Commission Staff encouraged utilities to consider how battery storage can be incorporated into a CSP.<sup>22</sup> And in Docket AR 659, the Commission recently adopted revisions to the Small Generator Interconnection Rules that, among other changes, clarified that energy storage systems ("ESSs"), including batteries, can be a part of a Small Generator Facility:

(10) "Energy storage system" means a mechanical, electrical, or electrochemical means to store and release electrical energy, and its associated interconnection and control equipment. *For the purposes of these rules, an energy storage system can be considered part of a small generator*

---

<sup>22</sup> Order No. 19-392, Appendix A at 9. ("Staff encourages the utilities to consider storage and transfer trip as eligibility criteria, but does not want that process to interfere with the timely implementation of the CSP interconnection process.").

*facility or a small generator facility in whole that operates in parallel with the distribution system.*

OAR 860-082-0015 (10)(emphasis added). In order for Buckaroo 1 to utilize battery storage, PacifiCorp must agree to amend Buckaroo 1's IA and PPA. While PacifiCorp has not refused to do so, Sunthurst's repeated requests have gone unanswered. The Commission should include this change in amending the IA.

**7. Unwillingness to renegotiate the IAs and PPAs.** Complainants reasonably expected PacifiCorp to accommodate changes to the IAs. (Several changes were made necessary by PacifiCorp's excessive costs, improper delays in negotiations, and unreasonable timelines, while others resulted from external causes beyond the Parties' control). But that has not been the case. After Complainants publicly complained about PacifiCorp's interconnection process, in Docket No. UM 1930, and sent it a Notice of Intent to File a Complaint<sup>23</sup>, PacifiCorp has become less flexible, not more.

Complainants have been trying unsuccessfully since Fall 2023 to move forward the CODs for Pilot Rock 1, Pilot Rock 2, and Tutuilla so that they can close on financing for all projects. PacifiCorp took one month to respond, initially, and its responses have not been helpful. In February 2024, PacifiCorp declared defaults on Complainants' IAs while Complainants were still seeking modifications to the payment deadlines, project timelines, and other issues discussed above. When Complainants asked PacifiCorp to agree to not terminate the IAs pending the Commission's review of Complainants' IA-

---

<sup>23</sup> Complainant's November 29, 2023 Notice is attached, as **Attachment F**.

related claims, PacifiCorp, through its attorney, repeatedly refused to offer any assurances it would not terminate the IAs as soon as Sunday, April 7, thereby forcing Complainants to file an emergency motion for interim relief, which the Commission granted in part, on April 5, 2024.

**C. The Cumulative Harm of PacifiCorp's Obstacles to Community Solar.**

Cumulatively, all of the above caused great harm to Complainants. PacifiCorp's DTT requirements (which are based upon studies of unknown accuracy due to inaccurate model inputs described in Docket AR 659) are intended to prevent a situation so rare that it has never been observed. The total incremental cost of DTT in Complainants' IAs is about \$500,000, which is more than 25% of their \$1.82 Million total interconnection costs. The large, unnecessary cost of DTT contributes to poor project economics and long construction timelines, both of which make Complainants' Projects harder to finance.

The very long installation times and very early milestone payments further degrade Project economics, by forcing Complainants to finance the cost of interconnection for two years or more. PacifiCorp does not need to receive money far ahead of when it will spend it. Requiring Complainants to pay in full for services a year in advance, effectively providing an interest-free loan to PacifiCorp, is a novel rate design that has not been approved by the Commission, and serves no purpose commensurate with the burden it imposes on Complainants.

PacifiCorp's refusal to permit Complainants to reimburse interconnection expenses with interest is not reasonably necessary to protect ratepayers, because Complainants have been approved to receive C-REP grants, from which the



interconnection expenses can be repaid upon Project completion. Requiring payment in full prior to project completion prevents substantially increases Complainants' construction costs.

PacifiCorp's delays in executing the Pilot Rock 1 and Tutuilla PPAs prevented Complainants from finalizing financing for all of their projects during a period of rapidly rising interest rates. The Prime Lending rate rose nearly 1.75% during Complainants' PPA negotiations, causing Complainants' cost of finance to increase commensurately. The steep rise in financing costs rendered the finance package non-viable, forcing them to seek other lenders and contributors.

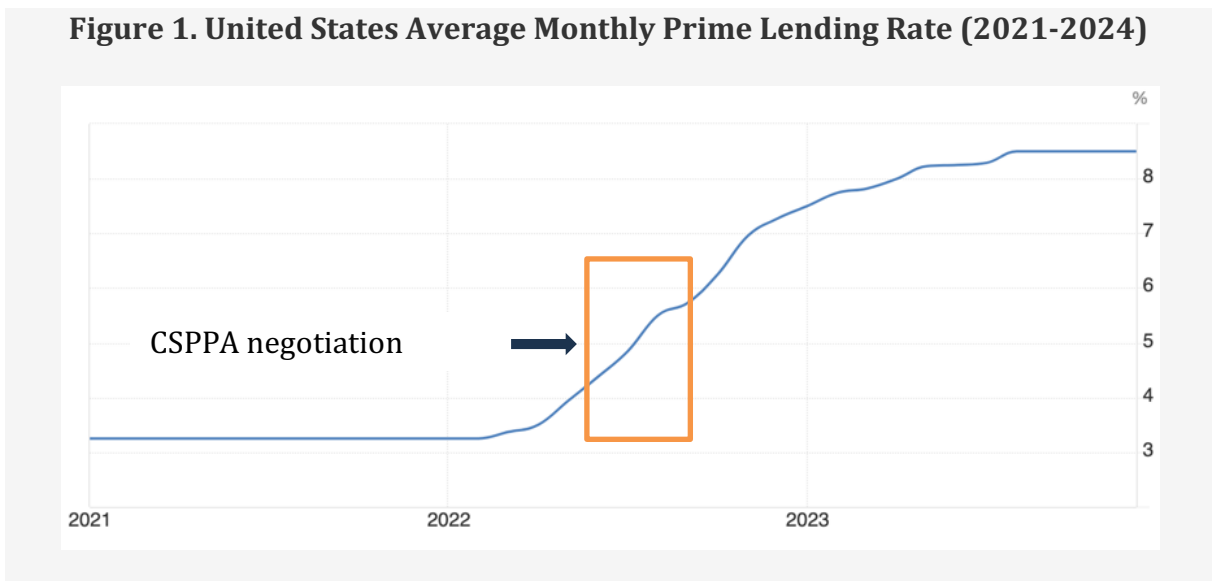

PacifiCorp's refusal to work with Pilot Rock 1, Pilot Rock 2 and the City of Pilot Rock to arrive at a workable, equitable arrangement to extend service to the Pilot Rock Industrial Park, Pilot Rock 1 and Pilot Rock 2, threatens to delay the Pilot Rock Projects

and/or allocate line extension costs inequitably. PacifiCorp's lack of commitment to accommodate ESS at Buckaroo 1 threatens to delay that Project indefinitely.

Each of the above issues, individually, may be surmountable. But cumulatively, they make the Community Solar Program a quixotic quest rather than a viable program, and show a pattern of PacifiCorp hostility towards Community Solar.

**D. Public Purpose of Community Solar.** Although Complainants are private companies, they are steeped in the public purposes of bringing the Community Solar Program created in SB 1547 to fruition, and furthering the carbon neutralization requirements of HB 2021. Many persons and organizations have put their faith in Complainants to deliver Community Solar Projects, and hope to benefit when those Projects are completed. Those persons and organizations include providers of low-income housing and individual low-income customer subscribers, private businesses, and agencies of the State of Oregon seeking to become carbon neutral. They also include rural governments, including the City of Pilot Rock, City of Pendleton, and CTUIR, all of whom have partnered with Complainants to bring Community Solar to their communities. The CTUIR are counting on the Tutuilla Project to provide affordable energy for low-income Tribal members, rental income for its Tribal industrial park, tax revenues, and technology transfer to the Tribe and its members.<sup>24</sup>

---

<sup>24</sup> See CTUIR's December 28, 2023 letter in support of the Tutuilla Project filed in Docket UM 2177 attached as **Attachment G** ("the Tutuilla Solar project will directly benefit the Umatilla Indian Reservation community through a subscription agreement whereby 10% of the power generated (i.e. financial benefits) will help off-set low-income tribal households' electricity bills. Additionally, annual fair market lease payments will be paid to the Tribal Government over the life of the project along with property taxes for providing essential governmental services.")

State tax-payers also have a stake in the success of the program, via state grants and tax exemptions. Several of Complainants' Projects received State Community Renewable Energy Grant Program (C-REP) grants, because they further carbon reduction requirements set forth in HB 2021. And, during the 2023 legislative session, the Legislature (with the acquiescence of rural Counties) extended the Net Metering tax exemptions from *ad valorem* property taxes to Community Solar, because they understood the importance of Community Solar in achieving Oregon's decarbonization goals.

The potential of Community Solar is tremendous but the current reality is troubling. A January 2024 OPUC Staff Report to the Commission documented the precarious condition of the Community Solar Program<sup>25</sup>: Of the 161 MW capacity initially allocated for Community Solar in 2019, only 29.1 MW have achieved operation. The program was intended to pay for itself through user fees, however fee revenue currently covers only 7.4 percent of program costs.

Complainants' five projects totaling 11.92 MWs, if completed, would increase total Community Solar capacity on PacifiCorp's system by nearly 500%, and the resulting Project fees would contribute approximately \$121,584<sup>26</sup> annually to Community Solar Program operating revenues. If PacifiCorp terminates Complainants' IAs, it is doubtful Complainants' reserved capacity will be developed—by Sunthurst or anyone else. The failure of the Sunthurst projects would cause irreparable harm, not only to Complainants

---

<sup>25</sup> <https://edocs.puc.state.or.us/efdocs/HAU/um1930hau326292023.pdf>

<sup>26</sup> 11,920kw x \$0.85/kw-mos x 12mos

and Sunthurst, but to all of the parties above, and Oregonians at large, who are invested heavily in the successful implementation of the Community Solar Program.

**E. Remedies sought.** PacifiCorp's actions violate several Commission rules, run afoul of PURPA and related state law, contravene the implied covenants of good faith in its contracts, and undermine state policies embedded in the Community Solar Program. The net results are unjust and unreasonable, and contrary to public policy. These facts, laws, and policy justify remedial action. Accordingly, Complainants ask the Commission to:

1. Declare DTT unreasonable here, where Complainants' CSPs will use smart-inverters interconnected to circuits without rotating generators or, alternatively, to require PacifiCorp allow DTT using low-side breakers at Complainants' Projects;

2. Declare unreasonable the prepayment milestones in Complainants' PPAs and direct PacifiCorp to allow Complainants with C-REP grants to pay for their Interconnection Facilities within 30 days of COD and receipt of grant funds, plus interest, up to the amount of their C-REP grant;

3. Declare unreasonable PacifiCorp's 2 year and 5 month schedule for completing the Pilot Rock 1, Pilot Rock 2, and Tutuilla interconnections and direct PacifiCorp to complete the interconnections in 2024 and within their original construction duration;

4. Direct PacifiCorp to devise a plan to construct the line extension to the City of Pilot Rock Industrial Park and the Pilot Rock Projects in time to accommodate the Pilot Rock Projects COD, with costs equitably apportioned among that line's users;

5. Direct PacifiCorp to amend the Buckaroo 1 IA and PPA as necessary to enable ESS at Buckaroo 1 and to compensate Buckaroo 1 for the capacity benefits of added ESS.

6. Direct PacifiCorp to negotiate reasonable extensions to Complainants' payment milestones and online dates in their IAs and PPAs, and not to terminate either without prior notice to the Commission; and

7. Provide such other relief it deems appropriate.

With the above corrections, Complainants' Projects can fulfill the purposes, private and public.

### III. SERVICE

Copies of all pleadings and correspondence should be served on Complainant's counsel and representative at the addresses below:

Ken Kaufmann, Attorney at Law 1785 Willamette Falls Drive, Suite 5 West Linn, OR 97068 ken@kaufmann.law	Daniel Hale PO Box 549 Stanfield OR 97875 daniel@sunthurstenergy.com
--	---

### IV. BASIS FOR COMMISSION JURISDICTION AND IDENTITY OF PARTIES

1.

Oregon Revised Statute 756.500 provides that any person may file a complaint before the Public Utility Commission against any person whose business or activities are regulated by some one or more of the statutes, jurisdiction for the enforcement or regulation of which is conferred upon the Commission.

2.

PacifiCorp is a public utility subject to the obligations to interconnect small generators set forth in OAR 860, Division 82 and OAR 860-029-0030. PacifiCorp’s Oregon headquarters is located at 825 NE Multnomah Street, Suite 2000, Portland, OR 97232.

3.

Complainants are domestic single purpose limited liability companies, wholly owned by Sunthurst Energy, LLC. Sunthurst is an Oregon limited liability company whose address is PO Box 549, Stanfield, Oregon 97875. Complainants’ Projects reside in PacifiCorp service territory and have contracted to sell net output to PacifiCorp as Public Utility Regulatory Policies Act (“PURPA”) Qualifying Facilities under Oregon’s Community Solar Program.

4.

**Sunthurst Project Interconnection Agreements.** Complainants’ parent, Sunthurst Energy, LLC, and PacifiCorp executed the original IAs for all five Projects. Sunthurst assigned the agreements to five special purpose, wholly owned, subsidiary limited liability companies in order to facilitate project financing. The agreements were last amended on May 22, 2023. The current Sunthurst-owned contracting parties are:

<u>Project</u>	<u>Contracting Party</u>	<u>Execution Date</u>
Pilot Rock 1 aka Pilot Rock Solar 1	Pilot Rock Solar 1, LLC	May 22, 2023
Pilot Rock 2 aka Pilot Rock Solar 2	Pilot Rock Solar 2, LLC	May 22, 2023
Tutuilla aka Tutuilla Solar	Tutuilla Solar, LLC	May 22, 2023

Buckaroo 1 aka Buckaroo Solar 1	Buckaroo Solar 1, LLC	May 22, 2023
Buckaroo 2 aka Buckaroo Solar 2	Buckaroo Solar 2, LLC	May 22, 2023

5.

Each of Complainants, above, also is contracted to sell Net Output from its Community Solar Project to PacifiCorp pursuant to a Community Solar Power Purchase Agreement (“PPA”).

## V. MATERIAL FACTS

6.

Complainants’ Projects are Pre-Certified Community Solar Projects under Oregon’s Community Solar Program.

7.

Many persons and organizations have put their faith in Complainants to deliver Community Solar Projects, and hope to benefit when those Projects are completed. Those persons and organizations include providers of low-income housing and individual low-income customer subscribers, private businesses, and agencies of the State of Oregon seeking to become carbon neutral. They also include rural governments, including the City of Pilot Rock, City of Pendleton, and the CTUIR, who have partnered with the Pilot Rock 2, Buckaroo 1, and Tutuilla Projects, respectively, to bring Community Solar to their respective communities.

8.

The CTUIR are counting on the Tutuilla Project to provide affordable energy for low-income Tribal members, rental income for its Tribal industrial park, tax revenues, and technology transfer to the Tribe and its members.

9.

Pilot Rock 2, Buckaroo 1, and Tutuilla, in partnership with the City of Pilot Rock, the City of Pendleton, and the CTUIR, respectively, have been awarded State Community Renewable Energy Grant Program (C-REP) grants between \$850,000 and \$1,000,000. Buckaroo 2 and Pilot Rock 1 may apply for C-REP grants in the future.

10.

Oregon's Community Solar Program has an initial goal of realizing 161 MW of operational Community Solar projects in investor-owned utility territory in Oregon.

11.

The Commission has stated publicly that the buildout of Community Solar Program capacity has not met the program's expectations.

12.

According to a January 2024 report from Staff, of the 29.1 MW of CSPs that have achieved operation, only 8% (2.4 MW) are sited in PacifiCorp territory.

13.



Complainants' five projects totaling 11.92 MWs, if completed, would contribute approximately \$121,584<sup>27</sup> annually to Community Solar Program operating revenues.

14.

If PacifiCorp terminates Complainants' IAs, it is doubtful Complainants' Projects will be developed—by Complainants or anyone else. The failure of the Complainants' Projects would cause irreparable harm, not only to Complainants, but to all of the parties above, and Oregonians at large, who are invested heavily in the successful implementation of the Community Solar Program.

**Direct Transfer Trip**

15.

Based upon the results of computer modeling of Complainants' planned facilities, PacifiCorp has specified DTT system protection equipment at each of Complainants' Projects.

16.

The incremental cost of DTT represents approximately 25% or more of Complainants' total interconnection costs payable to PacifiCorp.

17.

On March 8, 2024, in Order No. 24-068 at page 3, the Commission found that, going back many years, PacifiCorp utilized DC capacity ratings to model PV Solar projects, and

---

<sup>27</sup> 11,920kw x \$0.85/kw-mos x 12mos

that AC export capacity ratings were required for accurate simulation of DER related system impacts.

18.

PacifiCorp determines whether a Community Solar Project interconnection requires DTT capability, taking into account the ratio of the Project's output to the minimum load on its distribution circuit. The use of DC capacity data creates the likelihood PacifiCorp's model results show DTT is required when the actual AC output is below the threshold for requiring DTT.

19.

PacifiCorp's historic use of DC capacity ratings to model DER Solar such as Complainants' projects raises reasonable questions whether the adverse system impacts of Complainants' Projects meet the engineering threshold for DTT mitigation.

20.

PacifiCorp required DTT at Complainants' Projects to mitigate unintentional islanding (UI) during a system fault.

21.

The circuits to which Complainants' Projects will connect do not interconnect to a hydroelectric, gas turbine, windmill, or other rotating generator. PacifiCorp has not claimed knowledge of any instance (on its system or elsewhere) where UI has occurred

on a circuit that does not interconnect to a hydroelectric, gas turbine, windmill, or other rotating generator.

22.

DTT is one of several available means of quickly separating generation from the system when utility protection equipment detects an overcurrent fault. In addition to DTT, Complainants' inverters, and the utility grade relays at each of Complainants' Projects have the capability to detect abnormal conditions and quickly separate from the system.

23.

Nationwide, reliance on modern inverters in lieu of DTT is increasing, particularly for circuits that do not connect to a rotating generator.

24.

In Order No. 24-068, page 2, the Commission recently directed PacifiCorp to work with industry experts and inverter manufacturers to evaluate inverter equipment and settings options, with the expectation that it will specify inverter models and standardized configurations that can be safely relied upon without additional (DTT) equipment.

25.

The Commission recently updated the Small Generator Interconnection Rules to require the use of the 2018 version of IEEE-1547-2018. Those updated standards permit

DTT to be implemented at Complainants Projects at substantially lower cost than what PacifiCorp requires.

26.

Under new Section 7.4, IEEE-1547-2018 allows installation of the breaker used for DTT to be on the low side of the main transformer, whereas the previous standard did not.

27.

PacifiCorp has not yet procured or installed the DTT equipment specified in Complainants' IAs.

28.

In light of (a) PacifiCorp's flawed studies, (b) lack of evidence that inverter based solar connected to circuits that do not interconnect to rotating generators causes UI, (c) permissible low-side DTT under IEEE-1547-2018, and (d) the fact that PacifiCorp has not made irrevocable commitments to designing or building DTT, PacifiCorp's DTT requirement for Complainants' Projects is no longer just and reasonable .

**Planned Duration of Construction.**

29.

Complainants' IAs include a work schedule for PacifiCorp to install the interconnection. PacifiCorp determines the project schedule without Commission involvement.

30.

When Complainants asked PacifiCorp to postpone the overdue milestone payments in their IAs, in May 2023, PacifiCorp made unrequested changes to the construction schedules.

31.

The revised construction schedules in the May 2023 amendments increased PacifiCorp's time to construct the Pilot Rock 1 Solar, Pilot Rock 2 and Tutuilla interconnections (from execution date to finish) set forth in their IAs, from approximately *9 months* to approximately *2 years and 5 months*.

32.

The scope of work to construct the Pilot Rock 1, Pilot Rock 2 and Tutuilla interconnections does not reasonably require two years and 5 months to complete.

33.

The revised construction schedules in the May 2023 amendments increased PacifiCorp's time to construct the Buckaroo 1 and Buckaroo 2 interconnections (from execution date to finish) set forth in their IAs, from approximately *14 months* to approximately *2 years and 5 months*.

34.

The scope of work to construct the Buckaroo 1 and Buckaroo 2 interconnections does not reasonably require 2 years and 5 months to complete.

35.

Increasing interconnection construction timelines, from 9 months to 2 years, 5 months, has a substantial negative impact on the cost of building Complainants' Projects,

36.

Two-year, 5-month interconnection construction timelines undermine the viability of Complainants' projects and the Community Solar Program in general.

**Advance Payment Requirements.**

37.

Complainants' IAs require prepayment in four or five installments ("milestone payments"). PacifiCorp determines the timing and profile of milestone payments without Commission involvement.

38.

Complainants and PacifiCorp executed amendments to their 5 IAs in May 2023.

39.

In the May 2023 IA amendments, PacifiCorp accelerated the final milestone payment dates for Pilot Rock 1, Pilot Rock 2, and Tutuilla, relative to the project completion dates, by approximately 12 months. The amended agreements require payment of all interconnection costs approximately 15 months prior to the Commercial Operation Date.

40.

Complainants and PacifiCorp executed amendments to their IAs in May 2023. In the May 2023 IA amendments, PacifiCorp accelerated the final milestone payment dates for Buckaroo 1 and Buckaroo 2, relative to the project completion dates, by approximately 5 months. The amended agreements require payment of all interconnection costs approximately 10 months prior to the Commercial Operation Date.

41.

The accelerated payment requirements result in PacifiCorp collecting hundreds of thousands of dollars from Complainants many months before PacifiCorp will spend the money on Complainants' interconnections.

42.

PacifiCorp does not pay Complainants interest on Complainants' pre-payments.

43.

Complainants must borrow money to pay the milestone payments. The resulting interest charges will cost Complainants, on average, approximately \$12,000 per Project, per month.

44.

Accelerated payment requirements substantially hinder the viability of Complainants' projects and Community Solar Projects with PacifiCorp interconnections in general.

## Withholding Power Purchase Agreements to Interconnection Agreements

45.

Complainants' Projects are PURPA qualifying facilities.

46.

Complainants' rights to determine when they will incur a legally enforceable obligation to sell output from their qualifying facility is protected by regulations and case law under PURPA<sup>28</sup> and state laws implementing PURPA.

47.

PPA applications at PacifiCorp are processed through its Commercial and Trading function ("PacifiCorp C&T"). PacifiCorp employees that administer Complainants' IAs work in a separate PacifiCorp function called "PacifiCorp Transmission", but are the same legal entity as PacifiCorp C&T.

48.

On multiple occasions, PacifiCorp C&T delayed negotiation and/or execution of the Complainants' PPAs until PacifiCorp Transmission executed Complainants' IAs.

49.

The Commission admonished PacifiCorp for similar practices in the past.

---

<sup>28</sup> See, e.g. *Cedar Creek Wind*, LLC, 137 FERC ¶ 61,006.



50.

In Docket UM 1129, the Commission ruled that PacifiCorp could not require qualifying facilities to complete an interconnection study before negotiating a standard QF contract, and ordered PacifiCorp to remove the requirement from its proposed Schedule 38. Order No. 07-360, at 8.

51.

In Order No. 21-097 (pp 7-8) the Commission stated “[a]ccordingly, we expect PacifiCorp to continue with its new policy of offering draft PPAs prior to the completion of interconnection studies for non-standard contracts,” and directed Commission Staff to monitor PacifiCorp’s behavior toward qualifying facilities in the Transition Cluster and make recommendations if Staff determines additional procedural requirements are appropriate to ensure an efficient and fair processing of requests for PPAs for the transition cluster and/or future clusters.

52.

Withholding the Pilot Rock 1 and Tutuilla PPAs pending finalization of their IAs delayed their execution approximately 90 days. PacifiCorp took 120 days and 145 days, respectively, to execute Tutuilla and Pilot Rock 1 PPAs, whereas Pilot Rock 2 required approximately 70 days, and Buckaroo 1 and Buckaroo 2 PPAs were completed in only 32 days.

53.

Where a utility wrongfully withholds a draft or final PPA from a qualifying facility, the Commission may presume that harm resulted. Wrongful delay in negotiating such PPAs harms the Community Solar Program.

54.

Complainants were harmed by the 90-day delay, above. Because Complainants bundled their projects for more favorable project financing, the Pilot Rock 1 and Tutuilla PPA delays temporarily prevented Complainants from obtaining financing for any of its projects.

55.

During the 145 days required to enter into the Pilot Rock 1 PPA, the Prime Rate rose sharply, from approximately 4% to approximately 6.25%, and Complainants' construction financing interest rates rose commensurately. By the time all PPAs were executed, Complainants' window for locking in financing on favorable terms had closed.

56.

Because of these delays, Complainants were not ready to make the third milestone payments in their IAs, which came due in December 2022.

### **Line Extension at Pilot Rock 1 and Pilot Rock 2**

57.

In the time since the IAs were signed, City of Pilot Rock's development plans at the 440-acre Industrial Park where Pilot Rock 1 and Pilot Rock 2 are sited have accelerated, making the current interconnection plan for Pilot Rock 1 and Pilot Rock 2 obsolete.

58.

The Industrial Park will require electric service soon, likely in the next 18 months. City of Pilot Rock's desired line extension alignment for new service to its Industrial Park is blocked by the private line extension the IAs require Pilot Rock 1 to construct.

59.

The Pilot Rock 1 and Pilot Rock 2 Projects, when completed, will be approximately 2,000 feet due north of PacifiCorp's existing service. Their IAs specify Pilot Rock 1 and Pilot Rock 2 will build and own approximately 1,800 feet of a new, 12.5 kV, line, and the last approximately 200 feet (3 poles) will be built and owned by PacifiCorp ("Project line extension"). The Project line extension will be constructed within an 80-foot utility corridor, which must also accommodate all future utilities serving the Industrial Park. The Project line extension would not serve PacifiCorp customers, and would lie between the future PacifiCorp service and the county road. However, if PacifiCorp built the line extension to the Industrial Park first, and agreed to amend the Pilot Rock Projects' Point of Interconnection, moving it 2,000 feet north, Pilot Rock 1, Pilot Rock 2, and all future Industrial Park tenants could share use of the new PacifiCorp line extension, and a second

pole line would be unnecessary. Such arrangement is City of Pilot Rock's strongly preferred solution, and the best solution, because it minimizes duplication of facilities, thereby minimizing use of land and resources, and overall cost.

60.

City of Pilot Rock, City of Pendleton, and the Pilot Rock Projects have all asked PacifiCorp to implement a one pole-line solution for service to the Industrial Park and the Pilot Rock Projects, but PacifiCorp has not responded.

61.

It is unreasonable to require Pilot Rock 1 and Pilot Rock 2 to build a duplicate line extension alongside PacifiCorp's, where PacifiCorp will have to extend service to the Industrial Park regardless of the Pilot Rock Projects.

### **Buckaroo 1 Battery Energy Storage**

62.

Buckaroo 1 desires to add behind-the-meter battery storage to its Project.

63.

Commission Staff encouraged utilities to consider how battery storage can be incorporated into a CSP.<sup>29</sup> And in Docket AR 659, the Commission recently adopted revisions to the Small Generator Interconnection Rules that, among other changes, clarified that energy storage systems (“ESSs”), including batteries, can be a part of a Small Generator Facility:

(10) “Energy storage system” means a mechanical, electrical, or electrochemical means to store and release electrical energy, and its associated interconnection and control equipment. *For the purposes of these rules, an energy storage system can be considered part of a small generator facility or a small generator facility in whole that operates in parallel with the distribution system.*

OAR 860-082-0015 (10)(emphasis added).

64.

In order for Buckaroo 1 to utilize battery storage, PacifiCorp must agree to amend Buckaroo 1’s IA and PPA. While PacifiCorp has not refused to do so, Sunthurst’s repeated requests have gone unanswered.

---

<sup>29</sup> Order No. 19-392, Appendix A at 9. (“Staff encourages the utilities to consider storage and transfer trip as eligibility criteria, but does not want that process to interfere with the timely implementation of the CSP interconnection process.”).

65.

Absent direction and/or oversight by the Commission, PacifiCorp is unlikely to amend the Buckaroo 1 IA and PPA in a timely fashion.

66.

Delay in adding ESS to its IA and PPA are delaying completion of the Buckaroo 1 Project, which cannot operate until amendments to the IA and PPA are finalized.

67.

## VI. LEGAL CLAIM

**Complainants' First Claim for Relief—Modification. Complainants are entitled to modification of the Interconnection Agreements because PacifiCorp's performance under the current IAs is unjust and unreasonable.**

68.

Complainants reallege all the preceding paragraphs.

69.

Section 8.10 of the Pilot Rock 1 and Pilot Rock 2 IAs provides:

Either Party will have the right to make a unilateral filing with the Commission to modify this Agreement. This reservation of rights provision will [sic] includes but is not limited to modifications with respect to any rates terms and conditions, charges, classification of service, rule or regulation under tariff rates or any applicable State or Federal law or regulation. Each Party shall have the right to protest any such filing and to participate fully in any proceeding before the Commission in which such modifications may be considered.

70.

Section 8.10 of the Tutuilla, Buckaroo 1, and Buckaroo 2 IAs, provides:

Either Party will have the right to make a unilateral filing with the Commission to modify this Agreement. This reservation of rights provision will [sic] includes but is not limited to modifications with respect to any rates terms and conditions, charges, classification of service, rule or regulation under CSP Interconnection Procedures rates or any applicable State or Federal law or regulation. Each Party shall have the right to protest any such filing and to participate fully in any proceeding before the Commission in which such modifications may be considered.

71.

The differences in Section 8.10 arise because Pilot Rock 1 and Pilot Rock 2 signed an Interconnection Agreement for Small Generator Facility, whereas Tutuilla, Buckaroo 1, and Buckaroo 2 signed an Interconnection Agreement for a Community Solar Project. At the time Pilot Rock 1 and Pilot Rock 2 applied for interconnections, PacifiCorp's Community Solar Interconnection queue was not yet operational. For purposes of this complaint, the two provisions are essentially the same.

72.

ORS 756.040 authorizes the Commission to make use of the jurisdiction and powers of the office to protect such customers, and the public generally, from unjust and unreasonable exactions and practices and to obtain for them adequate service at fair and reasonable rates.

73.

The Complainants are only responsible for paying the interconnection costs that are reasonable, necessary to mitigate, and attributable to the adverse impacts caused by their interconnection. OAR 860-082-0015(1); OAR 860-082-0035(4).

74.

**Count 1--Direct Transfer Trip (DTT).** PacifiCorp's requirement of DTT with high-side, high-speed relays on Complainants' Projects is unjust and unreasonable where final design and procurement have not occurred, where Complainants' Projects will use IEEE 1547-2018 smart inverters and are the only generation located on their circuits; where the cost of the specified DTT is approximately \$100,000 per Project; where DTT would be a tertiary level of protection for a theoretical adverse effect that has never been observed in the real world, where cheaper alternatives providing comparable system protection are available; and where PacifiCorp may have used incorrect inputs which grossly overestimated the net export of Complainants' Projects.

75.

**Count 2--Planned Duration of Construction.** PacifiCorp's construction durations for Complainants' interconnections falls short of minimum acceptable public utility standards of service and are unreasonable, where Complainants planned and undertook their Projects in reliance upon PacifiCorp's typical construction timelines at that time, which were much shorter than the 2 years and 5 months the current IAs require, and where PacifiCorp proposed to do the same work in 9 months (or 14 months) less than a year prior, and where Oregon Community Solar is an important part of the State's clean energy policies being harmed by delayed interconnection timelines.

76.

**Count 3--Advance Payment Requirements.** Given overall Oregon Community Solar policy considerations, and other facts alleged above, the prepayment timelines in



Complainants' May 22, 2023 IAs, including the requirement of full prepayment up to 15 months before scheduled Commercial Operation dates, are unjust and unreasonable, where PacifiCorp will not perform services for many months after payment.

77.

**Count 4--Tying PPAs to Interconnection Agreements.** PacifiCorp's refusal to negotiate and/or execute Complainants' QF PPAs until Complainants had an executed interconnection agreement is unjust and unreasonable, where it deprived Complainants of their right under PURPA to determine when they would obligate their projects to sell output<sup>30</sup>, contravened the intent of past Orders of this Commission, and substantially delayed Complainants' efforts to obtain financing for their projects.

78.

**Count 5--Termination for Non-payment.** Given the totality of circumstances, including multi-year delays in processing PPA requests, lengthy delays on interconnection construction timelines, and overall Oregon Community Solar policy considerations, PacifiCorp's declaration of default, and threat to terminate the Complainants' IAs, is not just and reasonable.

---

<sup>30</sup> See, e.g. *FLS Energy, Inc.*, 157 FERC P61,211, 61730, 2016 FERC LEXIS 2167, \*17012 (F.E.R.C. December 15, 2016).

79.

All five counts alleged above substantially harmed Complainants (and the Community Solar Program) by delaying development and increasing costs, which are preventing Complainants from achieve operation in PacifiCorp territory.

**Complainants' Second Claim for Relief—Violation of OAR 860-082-0035(4). Complainants are entitled to not pay for DTT because PacifiCorp's conclusion that Complainant's Projects will cause UI is not supported by substantial evidence.**

80.

Complainants reallege all the preceding paragraphs.

81.

PacifiCorp has not shown that UI is a likely adverse affect of Complainants' Projects, and therefore is not entitled to require Complainants to pay for DTT.

**Complainants' Third Claim for Relief—Implied Covenant of Good Faith when Performing the IAs and PPAs. Complainants are entitled to modification because the IAs and PPAs require PGE to implement them in good faith, and PGE has not done so.**

82.

Complainants reallege all the preceding paragraphs.

83.

PacifiCorp has an obligation of good faith and fair dealing to facilitate the performance of the contracts it signs, including Complainants, where it is consistent with and in furtherance of the agreed upon terms of the contracts or where it effectuates the reasonable expectations of the parties.

84.

**Count 1—Change Line Extension at Pilot Rock 1 and Pilot Rock 2**

PacifiCorp has not fulfilled its duty of good faith and fair dealing where it failed to respond to repeated requests to modify the Pilot Rock 1 and Pilot Rock 2 IAs to eliminate unnecessary duplication of line extensions, and fairly allocate costs of the line extension among all users.

**Count 2 —Change Buckaroo 1 IA and PPA to permit ESS**

PacifiCorp has not fulfilled its duty of good faith and fair dealing where it failed to respond to repeated requests to modify the Buckaroo 1 IA and PPA to accommodate ESS and to compensate Buckaroo 1 for the added capacity benefits of its planned addition of ESS.

**VII. PRAYER FOR RELIEF**

85.

Complainants realleges all the preceding paragraphs.

86.

Wherefore, Complainants respectfully request that the Commission:

a. Declare DTT unreasonable here, where Complainants' Projects will use smart-inverters interconnected to circuits without rotating generators or, in the alternative, declare that DTT with high side breakers is unreasonable where low side breakers can provide comparable protection at lower cost;

b. Declare unreasonable the prepayment milestones in Complainants' PPAs and direct PacifiCorp to allow Complainants with C-REP grants to pay for their Interconnection Facilities within 30 days of COD and receipt of grant funds, plus interest, up to the amount of their C-REP grant;

c. Declare unreasonable PacifiCorp's 2-year, 5-month schedule for completing the Pilot Rock 1, Pilot Rock 2, and Tutuilla interconnections and direct PacifiCorp to complete the interconnections in 2024 and within the construction durations set forth in the original IAs;

d. Direct PacifiCorp to devise a plan to construct the line extension to the City of Pilot Rock Industrial Park and the Pilot Rock Projects in time to accommodate the Pilot Rock Projects COD, with costs equitably apportioned among that line's users;

e. Direct PacifiCorp to amend the Buckaroo 1 IA and PPA as necessary to enable ESS at Buckaroo 1 and to compensate Buckaroo 1 for the capacity benefits of added ESS;

f. Direct PacifiCorp to negotiate reasonable extensions to Complainants' payment milestones and online dates, in the IAs and PPAs, and not to terminate either without prior notice to the Commission; and

g. Provide such other relief it deems appropriate.

With the above corrections, Complainants' Projects can fulfill the promise of CSP, private and public.

/// /// ///

Dated this 17<sup>th</sup> Day of April 2024.

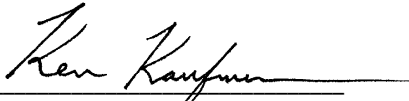
By:   
Kenneth E. Kaufmann, OSB 982672  
*Attorney for Complainants*

Attachment A  
Work in Progress at Pilot Rock 1, Pilot Rock 2, and Buckaroo 1



*Photo 1. 930 racking & equipment posts installed at Pilot Rock Solar 2 (taken April 11, 2024)*



*Photo 2. Racking, panels, inverters at Pilot Rock Solar 1 (taken April 11, 2024)*



*Photo 3. Row of racking installed at Buckaroo Solar 1 (taken April 11, 2024)*

**Attachment B**  
to First Amended Complaint

Interconnection Agreements  
between  
Complainants  
And  
PacifiCorp

**Table of Contents**

<b>Project</b>	<b>Page</b>
<b>Pilot Rock Solar 1</b>	
160314 Q0666 OGIA - Pilot Rock 1 IA dated March 14, 2016	2
160620 Q0666 Amendment dated June 20, 2016	31
161011 Q0666 Amendment dated October 11, 2016	35
171127 Q0666 Amendment dated November 27, 2017	39
181106 Q0666 Amendment dated November 6, 2018	43
220317 Q0666 Amendment dated March 17, 2022	47
220815 Q0666 Amendment dated August 15, 2022	57
230419 Q0666 Amendment dated April 19, 2023	69
230522 Q0666 Amendment dated May 22, 2023	74
<b>Pilot Rock Solar 2</b>	
220317 Q1045 OGIA - Pilot Rock 2 IA dated March 17, 2022	79
220816 Q1045 Amendment dated August 16, 2022	110
230522 Q1045 Amendment dated May 22, 2023	119
<b>Tutuilla Solar</b>	
211228 OCS024 SGIA - Tutuilla IA dated December 28, 2021	124
220815 OCS024 Amendment dated August 15, 2022	154
230522 OCS024 Amendment dated May 22, 2023	161
<b>Buckaroo Solar 1</b>	
220930 OCS062 Buckaroo 1 IA dated September 30, 2022	165
230522 OCS062 Amendment dated May 22, 2023	196
<b>Buckaroo Solar 2</b>	
220930 OCS063 Buckaroo 2 IA dated September 30, 2022	201
230522 OCS063 Amendment dated May 22, 2023	231



RECEIVED

MAR Form 8  
1 2016

TRANSMISSION SERVICES  
PACIFICORP

**Interconnection Agreement for Small Generator Facility  
Tier 1, Tier 2, Tier 3 or Tier 4 Interconnection  
(Small Generator Facilities with Electric Nameplate Capacities of 10MW or less)**

MAR 11 2016

This Interconnection Agreement for Small Generator Facility (“Agreement”) is made and entered into this 14<sup>th</sup> day of MARCH, 2016 by and between Sunthurst Energy, LLC (Pilot Rock, Q0666), a Limited Liability Company organized and existing under the laws of the State of Oregon, (“Interconnection Customer”) and PacifiCorp, a Corporation, existing under the laws of the State of Oregon, (“Public Utility”). The Interconnection Customer and Public Utility may be referred to hereinafter singly as a “Party” or collectively as the “Parties.”

**Recitals:**

**Whereas**, the Interconnection Customer is proposing to develop a Small Generator Facility, or to add generating capacity to an existing Small Generator Facility, consistent with the Application completed on May 7, 2015;

**Whereas**, the Interconnection Customer desires to interconnect the Small Generator Facility with Public Utility’s Transmission System and/or Distribution System (“T&D System”) in the State of Oregon; and

**Whereas**, the interconnection of the Small Generator Facility and the Public Utility’s T&D System is subject to the jurisdiction of the Public Utility Commission of Oregon (“Commission”) and governed by OPUC Rule OAR 860, Division 082 (the “Rule”).

**Now, therefore**, in consideration of and subject to the mutual covenants contained herein, the Parties agree as follows:

**Article 1.      Scope and Limitations of Agreement**

**1.1      Scope**

This Agreement establishes the standard terms and conditions under which the Small Generator Facility with a Nameplate Capacity of no more than 10 megawatts (“MW”) will interconnect to, and operate in Parallel with, the Public Utility’s T&D System. The Commission has approved standard terms and conditions governing this class of interconnection. Any additions, deletions or changes to the standard terms and conditions of interconnection approved by the Commission must be mutually agreed by the Parties or, if required by the Rule, any such changes must be approved by the Commission. Terms with initial capitalization, when used in this Agreement, shall have the meanings given in the Rule. This Agreement shall be construed where possible to be consistent with the Rules; to the extent this Agreement conflicts with the Rule, the Rule shall take precedence.

**1.2      No Agreement Regarding Power Purchase, Transmission, or Delivery**

This Agreement does not constitute an agreement to purchase, transmit, or deliver any power or capacity from the interconnected Small Generating Facility nor does it constitute



**Interconnection Agreement for Small Generator Facility  
Tier 1, Tier 2, Tier 3 or Tier 4 Interconnection  
(Small Generator Facilities with Electric Nameplate Capacities of 10MW or less)**

an electric service agreement.

MAR 11 2007

**1.3 Other Agreements**

Nothing in this Agreement is intended to affect any other agreement between the Public Utility and the Interconnection Customer or any other interconnected entity. If the provisions of this Agreement conflict with the provisions of any other Public Utility tariff, the Public Utility tariff shall control.

**1.4 Responsibilities of the Parties**

- 1.4.1 The Parties shall perform all obligations of this Agreement in accordance with all applicable laws.
- 1.4.2 The Interconnection Customer will construct, own, operate, and maintain its Small Generator Facility in accordance with this Agreement, IEEE Standard 1547 (2003 ed), IEEE Standard 1547.1 (2005 ed), the National Electrical Code (2005 ed) and applicable standards required by the Commission.
- 1.4.3 Each Party shall be responsible for the safe installation, maintenance, repair and condition of their respective lines and appurtenances on their respective sides of the Point of Interconnection. Each Party shall provide Interconnection Facilities that adequately protect the other Parties' facilities, personnel, and other persons from damage and injury. The allocation of responsibility for the design, installation, operation, maintenance and ownership of Interconnection Facilities is prescribed in the Rule and this Agreement and the attachments to this Agreement.

**1.5 Parallel Operation and Maintenance Obligations**

Once the Small Generator Facility has been authorized to commence Parallel Operation by execution of this Agreement and satisfaction of Article 2.1 of this Agreement, the Interconnection Customer will abide by all written provisions for operating and maintenance as required by this Agreement and any attachments to this Agreement as well as by the Rule and as detailed by the Public Utility in Form 7, title "Interconnection Equipment As-Built Specifications, Initial Settings and Operating Requirements".

**1.6 Metering & Monitoring**

The Interconnection Customer will be responsible for metering and monitoring as required by OAR 860-082-0070 and as may be detailed in any attachments to this Agreement.

**1.7 Power Quality**

The Interconnection Customer will design its Small Generator Facility to maintain a composite power delivery at continuous rated power output at the Point of Interconnection that meets the requirements set forth in IEEE 1547. The Public Utility may, in some

**Interconnection Agreement for Small Generator Facility  
Tier 1, Tier 2, Tier 3 or Tier 4 Interconnection  
(Small Generator Facilities with Electric Nameplate Capacities of 10MW or less)**

circumstances, also require the Interconnection Customer to follow voltage or VAR schedules used by similarly situated, comparable generators in the control area. Any special operating requirements will be detailed in Form 7 and completed by the Public Utility as required by the Rule. The Public Utility shall not impose additional requirements for voltage or reactive power support outside of what may be required to mitigate impacts caused by interconnection of the Small Generator Facility to the Public Utility's system.

**Article 2.      Inspection, Testing, Authorization, and Right of Access**

**2.1      Equipment Testing and Inspection**

The Interconnection Customer will test and inspect its Small Generator Facility and Interconnection Facilities prior to interconnection in accordance with IEEE 1547 Standards as provided for in the Rule. The Interconnection will not be final and the Small Generator Facility shall not be authorized to operate in parallel with the Public Utility's T&D System until the Witness Test and Certificate of Completion provisions in the Rule have been satisfied. The Interconnection Customer shall pay or reimburse the Public Utility for its costs to participate in the Witness Test. Operation of the Small Generator Facility requires an effective Interconnection Agreement; electricity sales require a Power Purchase Agreement.

To the extent that the Interconnection Customer decides to conduct interim testing of the Small Generator Facility prior to the Witness Test, it may request that the Public Utility observe these tests. If the Public Utility agrees to send qualified personnel to observe any interim testing proposed by the Interconnection Customer, the Interconnection Customer shall pay or reimburse the Public Utility for its cost to participate in the interim testing. If the Interconnection Customer conducts interim testing and such testing is observed by the Public Utility and the results of such interim testing are deemed acceptable by the Public Utility (hereinafter a "Public Utility-approved interim test"), then the Interconnection Customer may request that such Public Utility-approved interim test be deleted from the final Witness Testing. If the Public Utility elects to repeat any Public Utility-approved interim test as part of the final Witness Test, the Public Utility will bare its own expenses associated with participation in the repeated Public Utility-approved interim test.

**2.2      Right of Access:**

As provided in OAR 860-082-0030(5), the Public Utility will have access to the Interconnection Customer's premises for any reasonable purpose in connection with the Interconnection Application or any Interconnection Agreement that is entered in to pursuant to the Rule or if necessary to meet the legal obligation to provide service to its customers. Access will be requested at reasonable hours and upon reasonable notice, or at any time without notice in the event of an emergency or hazardous condition.

**Interconnection Agreement for Small Generator Facility  
Tier 1, Tier 2, Tier 3 or Tier 4 Interconnection  
(Small Generator Facilities with Electric Nameplate Capacities of 10MW or less)**

**Article 3. Effective Date, Term, Termination, and Disconnection**

**3.1 Effective Date**

The Agreement shall become effective upon execution by the Parties.

**3.2 Term of Agreement**

The Agreement will be effective on the Effective Date and will remain in effect for a period of twenty (20) years or the life of the Power Purchase agreement, whichever is shorter or a period mutually agreed to by the Parties, unless terminated earlier by the default or voluntary termination by the Interconnection Customer or by action of the Commission.

**3.3 Termination**

No termination will become effective until the Parties have complied with all provisions of OAR 860-082-0080 and this Agreement that apply to such termination.

3.3.1 The Interconnection Customer may terminate this Agreement at any time by giving the Public Utility twenty (20) Business Days written notice.

3.3.2 Either Party may terminate this Agreement after default pursuant to Article 5.6 of this Agreement.

3.3.3 The Commission may order termination of this Agreement.

3.3.4 Upon termination of this Agreement, the Small Generator Facility will be disconnected from the Public Utility's T&D System at the Interconnection Customer's expense. The termination of this Agreement will not relieve either Party of its liabilities and obligations, owed or continuing at the time of the termination.

3.3.4 The provisions of this Article 3.3 shall survive termination or expiration of this Agreement.

**3.4 Temporary Disconnection**

The Public Utility or Interconnection Customer may temporarily disconnect the Small Generator Facility from the Public Utility's T&D System for so long as reasonably necessary, as provided in OAR 860-082-0075 of the Rule, in the event one or more of the following conditions or events occurs:

3.4.1 Under emergency conditions, the Public Utility or the Interconnection Customer may immediately suspend interconnection service and temporarily disconnect the Small Generator Facility without advance notice to the other Party. The Public Utility shall notify the Interconnection Customer promptly when it becomes aware

**Interconnection Agreement for Small Generator Facility**  
**Tier 1, Tier 2, Tier 3 or Tier 4 Interconnection**  
**(Small Generator Facilities with Electric Nameplate Capacities of 10MW or less)**

of an emergency condition that may reasonably be expected to affect the Small Generator Facility operation. The Interconnection Customer will notify the Public Utility promptly when it becomes aware of an emergency condition that may reasonably be expected to affect the Public Utility's T&D System. To the extent information is known, the notification shall describe the emergency condition, the extent of the damage or deficiency, the expected effect on the operation of both Parties' facilities and operations, its anticipated duration, and the necessary corrective action.

- 3.4.2 For routine Maintenance, Parties will make reasonable efforts to provide five Business Days notice prior to interruption caused by routine maintenance or construction and repair to the Small Generator Facility or Public Utility's T&D system and shall use reasonable efforts to coordinate such interruption.
- 3.4.3 The Public Utility shall use reasonable efforts to provide the Interconnection Customer with prior notice of forced outages of the T&D System. If prior notice is not given, the Public Utility shall, upon request, provide the Interconnection Customer written documentation after the fact explaining the circumstances of the disconnection.
- 3.4.4 For disruption or deterioration of service, where the Public Utility determines that operation of the Small Generator Facility will likely cause disruption or deterioration of service to other customers served from the same electric system, or if operating the Small Generator Facility could cause damage to the Public Utility's T&D System, the Public Utility may disconnect the Small Generator Facility. The Public Utility will provide the Interconnection Customer upon request all supporting documentation used to reach the decision to disconnect. The Public Utility may disconnect the Small Generator Facility if, after receipt of the notice, the Interconnection Customer fails to remedy the adverse operating effect within a reasonable time which shall be at least five Business Days from the date the Interconnection Customer receives the Public Utility's written notice supporting the decision to disconnect, unless emergency conditions exist, in which case the provisions of 3.4.1 of the agreement apply.
- 3.4.5 If the Interconnection Customer makes any change to the Small Generating Facility, the Interconnection Equipment, the Interconnection Facilities, or to any other aspect of the interconnection, other than Minor Equipment Modifications, without prior written authorization of the Public Utility, the Public Utility will have the right to disconnect the Small Generator Facility until such time as the impact of the change has been studied by the Public Utility and any reasonable requirements or additional equipment or facilities required by the Public Utility to address any impacts from the changes have been implemented by the Parties and approved in

**Interconnection Agreement for Small Generator Facility  
Tier 1, Tier 2, Tier 3 or Tier 4 Interconnection  
(Small Generator Facilities with Electric Nameplate Capacities of 10MW or less)**

writing by the Public Utility. The requirement to apply to the Public Utility for study and approve of modifications is governed by OAR 860-082-0005 (b).

**3.5 Restoration of interconnection:**

MAP 11 2007

The Parties shall cooperate with each other to restore the Small Generator Facility, Interconnection Facilities, and Public Utility's T&D System to their normal operating state as soon as reasonably practicable following any disconnection pursuant to Article 3.4.

**Article 4. Cost Responsibility and Billing:**

As provided in OAR 860-082-0035, the Interconnection Customer is responsible for the cost of all facilities, equipment, modifications and upgrades needed to facilitate the interconnection of the Small Generator Facility to the Public Utility's T&D System.

**4.1 Minor T&D System Modifications:**

As provided in the Rule addressing Tier 2 review (OAR 860-082-0050) and in the Rule addressing Tier 3 review (OAR 860-082-0055), it may be necessary for the Parties to construct certain Minor Modifications in order to interconnect under Tier 2 or Tier 3 review. The Public Utility has itemize any required Minor Modifications in the attachments to this Agreement, including a good-faith estimate of the cost of such Minor Modifications and the time required to build and install such Minor Modifications. The Interconnection Customer agrees to pay the costs of such Minor Modifications.

**4.2 Interconnection Facilities:**

The Public Utility has identified under the review procedures of a Tier 2 review or under a Tier 4 Facilities Study, the Interconnection Facilities necessary to safely interconnect the Small Generator Facility with the Public Utility. The Public Utility has itemized the required Interconnection Facilities in the attachments to this Agreement, including a good-faith estimate of the cost of the facilities and the time required to build and install those facilities. The Interconnection Customer is responsible for the cost of the Interconnection Facilities.

**4.3 Interconnection Equipment:**

The Interconnection Customer is responsible for all reasonable expenses, including overheads, associated with owning, operating, maintaining, repairing, and replacing its Interconnection Equipment.

**4.4 System Upgrades:**

The Public Utility will design, procure, construct, install, and own any System Upgrades. The actual cost of the System Upgrades, including overheads, will be directly assigned to the Interconnection Customer. An Interconnection Customer may be entitled to financial compensation from other Public Utility Interconnection Customers who, in the future, benefit from the System Upgrades paid for by the Interconnection Customer. Such compensation will be governed by separate rules promulgated by the Commission or by

UM 2322--FIRST AMENDED COMPLAINT

**Interconnection Agreement for Small Generator Facility  
Tier 1, Tier 2, Tier 3 or Tier 4 Interconnection  
(Small Generator Facilities with Electric Nameplate Capacities of 10MW or less)**

terms of a tariff filed and approved by the Commission. Such compensation will only be available to the extent provided for in the separate rules or tariff.

**4.5 Adverse System Impact:**

The Public Utility is responsible for identifying the possible Affected Systems and coordinating with those identified Affected Systems, to the extent reasonably practicable, to allow the Affected System owner an opportunity to identify Adverse System Impacts on its Affected System, and to identify what mitigation activities or upgrades may be required on the Public Utility's system or on the Affected System to address impacts on Affected Systems and accommodate a Small Generator Facility. Such coordination with Affected System owners shall include inviting Affected System owners to scoping meetings between the Public Utility and the Interconnection Customer and providing the Affected System owner with study results and other information reasonably required and requested by the Affected System owner to allow the Affected System owner to assess impacts to its system and determine required mitigation, if any, for such impacts. The Parties acknowledge that the Public Utility cannot compel the participation of the Affected System owner and that the Public Utility is not itself responsible for identifying impacts or mitigation associated with an Affected System. The actual cost of any actions taken to address the Adverse System Impacts, including overheads, shall be directly assigned to the Interconnection Customer. The Interconnection Customer may be entitled to financial compensation from other Public Utilities or other Interconnection Customers who, in the future, utilize the upgrades paid for by the Interconnection Customer, to the extent allowed or required by the Commission. Such compensation will only be available to the extent provided for in the separate rules, Commission order or tariff. If the Parties have actual knowledge of an Adverse System Impact on an Affected System, the Interconnection Customer shall not interconnect and operate its Small Generator Facility in parallel with the Public Utility's system, and the Public Utility shall not authorize or allow the continued interconnection or parallel operation of the Small Generator Facility, unless and until such Adverse System Impact has been addressed to the reasonable satisfaction of the Affected System owner.

**4.6 Deposit and Billings:**

The Interconnection Customer agrees to pay to the Public Utility a deposit toward the cost to construct and install any required Interconnection Facilities and/or System Upgrades. The amount of the deposit shall be (select one of the following):

The Parties have not agreed to a schedule of progress payments and the Interconnection Customer shall pay a deposit equal to 100 percent of the estimated cost of the Interconnection Facilities and System Upgrades – the amount of the deposit shall be \$805,000; or

**Interconnection Agreement for Small Generator Facility  
Tier 1, Tier 2, Tier 3 or Tier 4 Interconnection  
(Small Generator Facilities with Electric Nameplate Capacities of 10MW or less)**

The Parties have agreed to progress payments and final payment under the schedule of payments attached to this Agreement; the Interconnection Customer shall pay a deposit equal to the lesser of (a) 25 percent of the estimated cost of the Interconnection Facilities and System Upgrades, or (b) \$10,000 – the amount of the deposit shall be \$10,000.

If the actual costs of Interconnection Facilities and/or System Upgrades are different than the deposit amounts and/or progress and final payments provided for above, then the Interconnection Customer shall pay the Public Utility any balance owing or the Public Utility shall refund any excess deposit or progress payment within 20 days of the date actual costs are determined

**Article 5. Assignment, Liability, Indemnity, Force Majeure, Consequential Damages, and Default**

**5.1 Assignment**

The Interconnection Agreement may be assigned by either Party upon fifteen (15) Business Days prior written notice. Except as provided in Articles 5.1.1 and 5.1.2, said assignment shall only be valid upon the prior written consent of the non-assigning Party, which consent shall not be unreasonably withheld.

5.1.1 Either Party may assign the Agreement without the consent of the other Party to any affiliate (which shall include a merger of the Party with another entity), of the assigning Party with an equal or greater credit rating and with the legal authority and operational ability to satisfy the obligations of the assigning Party under this Agreement;

5.1.2 The Interconnection Customer shall have the right to assign the Agreement, without the consent of the Public Utility, for collateral security purposes to aid in providing financing for the Small Generator Facility. For Small Generator systems that are integrated into a building facility, the sale of the building or property will result in an automatic transfer of this agreement to the new owner who shall be responsible for complying with the terms and conditions of this Agreement.

5.1.3 Any attempted assignment that violates this Article is void and ineffective. Assignment shall not relieve a Party of its obligations, nor shall a Party's obligations be enlarged, in whole or in part, by reason thereof. An assignee is responsible for meeting the same obligations as the assigning Interconnection Customer.

**5.2 Limitation of Liability and Consequential Damages**

A Party is liable for any loss, cost claim, injury, or expense including reasonable attorney's fees related to or arising from any act or omission in its performance of the provisions of

**Interconnection Agreement for Small Generator Facility  
Tier 1, Tier 2, Tier 3 or Tier 4 Interconnection  
(Small Generator Facilities with Electric Nameplate Capacities of 10MW or less)**

this Agreement entered into pursuant to the Rule except as provided for in ORS 757.300(4)(c). Neither Party will seek redress from the other Party in an amount greater than the amount of direct damage actually incurred.

**5.3 Indemnity**

- 5.3.1 Liability under this Article 5.3 is exempt from the general limitations on liability found in Article 5.2.
- 5.3.2 The Parties shall at all times indemnify, defend, and hold the other Party harmless from, any and all damages, losses, claims, including claims and actions relating to injury to or death of any person or damage to property, demand, suits, recoveries, costs and expenses, court costs, attorney fees, and all other obligations by or to third parties, arising out of or resulting from the other Party's action or failure to meet its obligations under this Agreement on behalf of the indemnifying Party, except in cases of gross negligence or intentional wrongdoing by the indemnified Party.
- 5.3.3 If an indemnified person is entitled to indemnification under this Article 5.3 as a result of a claim by a third party, and the indemnifying Party fails, after notice and reasonable opportunity to proceed under this Article 5.3, to assume the defense of such a claim, such indemnified person may at the expense of the indemnifying Party contest, settle or consent to the entry of any judgment with respect to, or pay in full, such claim.
- 5.3.4 If an indemnifying party is obligated to indemnify and hold any indemnified person harmless under this Article 5.3, the amount owing to the indemnified person shall be the amount of such indemnified person's actual loss, net of any insurance or other recovery.
- 5.3.5 Promptly after receipt by an indemnified person of any claim or notice of the commencement of any action or administrative or legal proceeding or investigation as to which the indemnity provided for in this Article 5.3 may apply, the indemnified person shall notify the indemnifying party of such fact. Any failure of or delay in such notification shall not affect a Party's indemnification obligation unless such failure or delay is materially prejudicial to the indemnifying party.
- 5.3.6 The indemnifying Party shall have the right to assume the defense thereof with counsel designated by such indemnifying Party and reasonably satisfactory to the indemnified person. If the defendants in any such action include one or more indemnified persons and the indemnifying Party and if the indemnified person reasonably concludes that there may be legal defenses available to it and/or other indemnified persons which are different from or additional to those available to the



**Interconnection Agreement for Small Generator Facility  
Tier 1, Tier 2, Tier 3 or Tier 4 Interconnection  
(Small Generator Facilities with Electric Nameplate Capacities of 10MW or less)**

indemnifying Party, the indemnified person shall have the right to select separate counsel to assert such legal defenses and to otherwise participate in the defense of such action on its own behalf. In such instances, the indemnifying Party shall only be required to pay the fees and expenses of one additional attorney to represent an indemnified person or indemnified persons having such differing or additional legal defenses.

- 5.3.7 The indemnified person shall be entitled, at its expense, to participate in any such action, suit or proceeding, the defense of which has been assumed by the indemnifying Party. Notwithstanding the foregoing, the indemnifying Party (i) shall not be entitled to assume and control the defense of any such action, suit or proceedings if and to the extent that, in the opinion of the indemnified person and its counsel, such action, suit or proceeding involves the potential imposition of criminal liability on the indemnified person, or there exists a conflict or adversity of interest between the indemnified person and the indemnifying Party, in such event the indemnifying Party shall pay the reasonable expenses of the indemnified person, and (ii) shall not settle or consent to the entry of any judgment in any action, suit or proceeding without the consent of the indemnified person, which shall not be reasonably withheld, conditioned or delayed.

**5.4 Consequential Damages**

Neither Party shall be liable to the other Party, under any provision of this Agreement, for any losses, damages, costs or expenses for any special, indirect, incidental, consequential, or punitive damages, including but not limited to loss of profit or revenue, loss of the use of equipment, cost of capital, cost of temporary equipment or services, whether based in whole or in part in contract, in tort, including negligence, strict liability, or any other theory of liability; provided, however, that damages for which a Party may be liable to the other Party under another agreement will not be considered to be special, indirect, incidental, or consequential damages hereunder.

**5.5 Force Majeure**

- 5.5.1 As used in this Agreement, a Force Majeure Event shall mean “any act of God, labor disturbance, act of the public enemy, war, acts of terrorism, insurrection, riot, fire, storm or flood, explosion, breakage or accident to machinery or equipment through no direct, indirect, or contributory act of a Party, any order, regulation or restriction imposed by governmental, military or lawfully established civilian authorities, or any other cause beyond a Party’s control. A Force Majeure Event does not include an act of negligence or intentional wrongdoing.”
- 5.5.2 If a Force Majeure Event prevents a Party from fulfilling any obligations under this Agreement, the Party affected by the Force Majeure Event (Affected Party) shall

1 1 WFC

**Interconnection Agreement for Small Generator Facility  
Tier 1, Tier 2, Tier 3 or Tier 4 Interconnection  
(Small Generator Facilities with Electric Nameplate Capacities of 10MW or less)**

promptly notify the other Party of the existence of the Force Majeure Event. The notification must specify in reasonable detail the circumstances of the Force Majeure Event, its expected duration, and the steps that the Affected Party is taking to mitigate the effects of the event on its performance, and if the initial notification was verbal, it should be promptly followed up with a written notification. The Affected Party shall keep the other Party informed on a continuing basis of developments relating to the Force Majeure Event. Until the Force Majeure Event ends the Affected Party will be entitled to suspend or modify its performance of obligations under this Agreement (other than the obligation to make payments) only to the extent that the effect of the Force Majeure Event cannot be reasonably mitigated. The Affected Party will use reasonable efforts to resume its performance as soon as possible. The Parties shall immediately report to the Commission should a Force Majeure Event prevent performance of an action required by the Rule that the Rule does not permit the Parties to mutually waive.

**5.6 Default**

- 5.6.1 No default shall exist where such failure to discharge an obligation (other than the payment of money) is the result of a Force Majeure Event as defined in this Agreement, or the result of an act or omission of the other Party. Upon a breach, the non-breaching Party shall give written notice of such breach to the breaching Party. Except as provided in Article 5.6.2, the breaching Party shall have sixty (60) Calendar Days from receipt of the breach notice within which to cure such breach; provided however, if such breach is not capable of cure within 60 Calendar Days, the breaching Party shall commence such cure within twenty (20) Calendar Days after notice and continuously and diligently complete such cure within six months from receipt of the breach notice; and, if cured within such time, the breach specified in such notice shall cease to exist.
- 5.6.2 If a breach is not cured as provided for in this Article 5.6, or if a breach is not capable of being cured within the period provided for herein, the non-breaching Party shall have the right to declare a default and terminate this Agreement by written notice at any time until cure occurs, and be relieved of any further obligation hereunder and, whether or not that Party terminates this Agreement, to recover from the breaching Party all amounts due hereunder, plus all other damages and remedies to which it is entitled at law or in equity. Alternatively, the non-breaching Party shall have the right to seek dispute resolution with the Commission in lieu of default. The provisions of this Article 5.6 will survive termination of the Agreement.

**Article 6. Insurance**

**Interconnection Agreement for Small Generator Facility  
Tier 1, Tier 2, Tier 3 or Tier 4 Interconnection  
(Small Generator Facilities with Electric Nameplate Capacities of 10MW or less)**

- 6.1 Pursuant to the Rule adopted by the Commission, the Public Utility may not require the Interconnection Customer to maintain general liability insurance in relation to the interconnection of a Small Generator Facility with an Electric Nameplate Capacity of 200 KW or less. With regard to the interconnection of a Small Generator Facility with an Electric Nameplate Capacity equal to or less than 10 MW but in excess of 200 KW, the Interconnection Customer shall, at its own expense, maintain in force throughout the period of this Agreement general liability insurance sufficient to protect any person (including the Public Utility) who may be affected by the Interconnection Customer's Small Generation Facility and its operation and such insurance shall be sufficient to satisfy the Interconnection Customer's indemnification responsibilities under Article 5.3 of this Agreement.
- 6.2 Within ten (10) days following execution of this Agreement, and as soon as practicable after the end of each fiscal year or at the renewal of the insurance policy and in any event within ninety (90) days thereafter, the Interconnection Customer shall provide the Public Utility with certification of all insurance required in this Agreement, executed by each insurer or by an authorized representative of each insurer.
- 6.3 All insurance required by this Article 6 shall name the Public, its parent, associated and Affiliate companies and their respective directors, officers, agents, servants and employees ("Other Party Group") as additional insured. All policies shall contain provisions whereby the insurers waive all rights of subrogation against the Other Party Group and provide thirty (30) Calendar Days advance written notice to the Other Party Group prior to anniversary date of cancellation or any material change in coverage or condition. The Interconnection Customer's insurance shall contain provisions that specify that the policies are primary and shall apply to such extent without consideration for other policies separately carried and shall state that each insured is provided coverage as though a separate policy had been issued to each, except the insurer's liability shall not be increased beyond the amount for which the insurer would have been liable had only one insured been covered. The insurance policies, if written on a Claims First Made Basis, shall be maintained in full force and effect for two (2) years after termination of this Agreement, which coverage may be in the form of tail coverage or extended reporting period coverage if agreed by the Parties.
- 6.4 The Parties agree to report to each other in writing as soon as practical all accidents or occurrences resulting in injuries to any person, including death, and any property damage arising out of this Agreement.
- 6.5 The requirements contained herein as to insurance are not intended to and shall not in any manner, limit or qualify the liabilities and obligations assumed by the Parties under this Agreement.

**Interconnection Agreement for Small Generator Facility  
Tier 1, Tier 2, Tier 3 or Tier 4 Interconnection  
(Small Generator Facilities with Electric Nameplate Capacities of 10MW or less)**

**Article 7.     **Dispute Resolution****

Parties will adhere to the dispute resolution provisions in OAR 860-082-0080.

**Article 8.     **Miscellaneous****

**8.1     **Governing Law, Regulatory Authority, and Rules****

The validity, interpretation and enforcement of the Agreement and each of its provisions shall be governed by the laws of the State of Oregon, without regard to its conflicts of law principles. The Agreement is subject to all applicable laws. Each Party expressly reserves the right to seek changes in, appeal, or otherwise contest any laws, orders, or regulations of a governmental authority.

**8.2     **Amendment****

The Parties may mutually agree to amend the Agreement by a written instrument duly executed by both Parties in accordance with provisions of the Rule and applicable Commission Orders and provisions of the laws of the State of Oregon.

**8.3     **No Third-Party Beneficiaries****

The Agreement is not intended to and does not create rights, remedies, or benefits of any character whatsoever in favor of any persons, corporations, associations, or entities other than the Parties, and the obligations herein assumed are solely for the use and benefit of the Parties, their successors in interest and where permitted, their assigns.

**8.4     **Waiver****

8.4.1   The failure of a Party to the Agreement to insist, on any occasion, upon strict performance of any provision of the Agreement will not be considered a waiver of any obligation, right, or duty of, or imposed upon, such Party.

8.4.2   The Parties may agree to mutually waive a section of this Agreement so long as prior Commission approval of the waiver is not required by the Rule.

8.4.3   Any waiver at any time by either Party of its rights with respect to the Agreement shall not be deemed a continuing waiver or a waiver with respect to any other failure to comply with any other obligation, right, duty of the Agreement. Any waiver of the Agreement shall, if requested, be provided in writing.

**8.5     **Entire Agreement****

This Agreement, including any supplementary Form attachments that may be necessary, constitutes the entire agreement between the Parties with reference to the subject matter hereof, and supersedes all prior and contemporaneous understandings or agreements, oral or written, between the Parties with respect to the subject matter of the Agreement. There are no other agreements, representations, warranties, or covenants that constitute any part

**Interconnection Agreement for Small Generator Facility  
Tier 1, Tier 2, Tier 3 or Tier 4 Interconnection  
(Small Generator Facilities with Electric Nameplate Capacities of 10MW or less)**

of the consideration for, or any condition to, either Party's compliance with its obligations under this Agreement.

**8.6 Multiple Counterparts**

This Agreement may be executed in two or more counterparts, each of which is deemed an original but all constitute one and the same instrument.

**8.7 No Partnership**

This Agreement will not be interpreted or construed to create an association, joint venture, agency relationship, or partnership between the Parties or to impose any partnership obligation or partnership liability upon either Party. Neither Party shall have any right, power or authority to enter into any agreement or undertaking for, or act on behalf of, or to act as or be an agent or representative of, or to otherwise bind, the other Party.

**8.8 Severability**

If any provision or portion of this Agreement shall for any reason be held or adjudged to be invalid or illegal or unenforceable by any court of competent jurisdiction or other governmental authority; (1) such portion or provision shall be deemed separate and independent; (2) the Parties shall negotiate in good faith to restore insofar as practicable the benefits to each Party that were affected by such ruling; and (3) the remainder of this Agreement shall remain in full force and effect.

**8.9 Subcontractors**

Nothing in this Agreement shall prevent a Party from utilizing the services of any subcontractor, or designating a third party agent as one responsible for a specific obligation or act required in this Agreement (collectively subcontractors), as it deems appropriate to perform its obligations under this Agreement; provided, however, that each Party will require its subcontractors to comply with all applicable terms and conditions of this Agreement in providing such services and each Party will remain primarily liable to the other Party for the performance of such subcontractor.

8.9.1 The creation of any subcontract relationship shall not relieve the hiring Party of any of its obligations under this Agreement. The hiring Party shall be fully responsible to the other Party for the acts or omissions of any subcontractor the hiring Party hires as if no subcontract had been made. Any applicable obligation imposed by this Agreement upon the hiring Party shall be equally binding upon, and will be construed as having application to, any subcontractor of such Party.

8.9.2 The obligations under this Article 8.9 will not be limited in any way by any limitation of subcontractor's insurance.

**8.10 Reservation of Rights**

**Interconnection Agreement for Small Generator Facility  
Tier 1, Tier 2, Tier 3 or Tier 4 Interconnection**  
(Small Generator Facilities with Electric Nameplate Capacities of 10MW or less)

Either Party will have the right to make a unilateral filing with the Commission to modify this Agreement. This reservation of rights provision will include but is not limited to modifications with respect to any rates terms and conditions, charges, classification of service, rule or regulation under tariff rates or any applicable State or Federal law or regulation. Each Party shall have the right to protest any such filing and to participate fully in any proceeding before the Commission in which such modifications may be considered.

**Article 9.**     **Notices and Records**

**9.1**     **General**

Unless otherwise provided in this Agreement, any written notice, demand, or request required or authorized in connection with this Agreement shall be deemed properly given if delivered in person, delivered by recognized national courier service, or sent by first class mail, postage prepaid, to the person specified below:

**9.2**     **Records**

The Public Utility will maintain a record of all Interconnection Agreements and related Form attachments for as long as the interconnection is in place as required by OAR 860-082-0065. The Public Utility will provide a copy of these records to the Interconnection Customer within 15 Business Days if a request is made in writing.

**If to the Interconnection Customer:**

Interconnection Customer: Sunthurst Energy, LLC  
Attention: Daniel Hale  
Address: 153 Lowell Ave  
City: Glendora State: California Zip: 91741  
Phone: 310-975-4732   Fax: 323-782-0760

**If to Public Utility:**

Public Utility: PacifiCorp  
Attention: Transmission Service  
Address: 825 NE Multnomah, Suite 550  
City: Portland State: Oregon Zip: 97232  
Phone: 503-813-6077   Fax: 503-813-6893

**9.3**     **Billing and Payment**

Billings and payments shall be sent to the addresses set out below: (complete if different than article 9.2 above)

**Interconnection Agreement for Small Generator Facility  
Tier 1, Tier 2, Tier 3 or Tier 4 Interconnection  
(Small Generator Facilities with Electric Nameplate Capacities of 10MW or less)**

**If to the Interconnection Customer**

Interconnection Customer: PILOT ROCK SOLAR 1 LLC 79 PFC  
Attention: DANIEL HALE  
Address: 43682 SW BREWER LANE  
City: PENDLETON State: OR Zip: 97001

**If to Public Utility**

Public Utility: PacifiCorp Transmission  
Attention: Central Cashiers Office  
Address: P.O. Box 2757  
City: Portland State: OR Zip: 97208-2757

**9.4 Designated Operating Representative**

The Parties will designate operating representatives to conduct the communications which may be necessary or convenient for the administration of the operations provisions of this Agreement. This person will also serve as the point of contact with respect to operations and maintenance of the Party's facilities (complete if different than article 9.2 above)

**Interconnection Customer's Operating Representative: SUNTHURST ENERGY, LLC**

Attention: DANIEL HALE  
Address: 153 LOWELL AVENUE  
City: GUENDORA State: CA Zip: 91741  
Phone: 310.975.4732 Fax: 323.782.0760 E-Mail: danielle@sunthurstenergy.com

**Public Utility's Operating Representative: PacifiCorp**

Attention: Grid Operations  
Address: 9915 S.E. Ankeny Street  
City: Portland State: OR Zip: 97216  
Phone: 503-251-5197 Fax: 503-251-5228

**9.5 Changes to the Notice Information**

Either Party may change this notice information by giving five Business Days written notice prior to the effective date of the change.

**Interconnection Agreement for Small Generator Facility  
Tier 1, Tier 2, Tier 3 or Tier 4 Interconnection  
(Small Generator Facilities with Electric Nameplate Capacities of 10MW or less)**

**Article 10. Signatures**

IN WITNESS WHEREOF, the Parties have caused this Agreement to be executed by their respective duly authorized representatives.

**For Public Utility:**

Name: *Keith Hal*

Title: *VP, Transmission*

Date: *3/14/16*

**For the Interconnection Customer:**

Name: *D Hal*

Title: *OWNER/PRINCIPAL*

Date: *3/9/16*



**Interconnection Agreement for Small Generator Facility  
Tier 1, Tier 2, Tier 3 or Tier 4 Interconnection  
(Small Generator Facilities with Electric Nameplate Capacities of 10MW or less)**

**Attachment 1**

**Description of Interconnection Facilities  
And Metering Equipment Operated or Maintained by the Public Utility**

Small Generating Facility: A 1.98 MW solar generating facility consisting of thirty-three (33) SMA MLX-60 60 kW inverters, connected to one (1) generation step up transformer (3 MVA, 5.75%), and one (1) 150 kVA grounding bank with an impedance of 5.75%, connected to Public Utility's Distribution System in Umatilla County, Oregon. See Attachment 2.

Interconnection Customer Interconnection Facilities: A short, 12.5 kV tie connecting the step-up transformer to the Interconnection Customer owned recloser and relay. Interconnection Customer will also own a gang-operated disconnect switch that Public Utility can access. See Attachment 2.

Public Utility's Interconnection Facilities: A short run of distribution circuit connected to a 12.5 kV disconnect switch, bi-directional revenue metering facilities and fiber optic cable equipment necessary for transfer-trip between the Small Generating Facility and Pilot Rock substation. See Attachment 2.

Estimated cost of Public Utility's Interconnection Facilities directly assigned to Interconnection Customer: \$203,000

Estimated Annual Operation and Maintenance Cost of Public Utility's Interconnection Facilities: \$1,500. Interconnection Customer shall be responsible for Public Utility's actual cost for maintenance of the Public Utility's Interconnection Facilities.

Point of Interconnection: The point where the Public Utility's Interconnection Facilities connect to the Public Utility's 12.5 kV distribution circuit 5W406 out of Pilot Rock substation. See Attachment 2.

Point of Change of Ownership: The point where the Interconnection Customer's Interconnection Facilities connect to the Public Utility's Interconnection Facilities. See Attachment 2.

**Interconnection Agreement for Small Generator Facility  
Tier 1, Tier 2, Tier 3 or Tier 4 Interconnection  
(Small Generator Facilities with Electric Nameplate Capacities of 10MW or less)**

**Attachment 2**

**One-line Diagram Depicting the Generating Facility, Interconnection Facilities, Metering Equipment, and Upgrades**

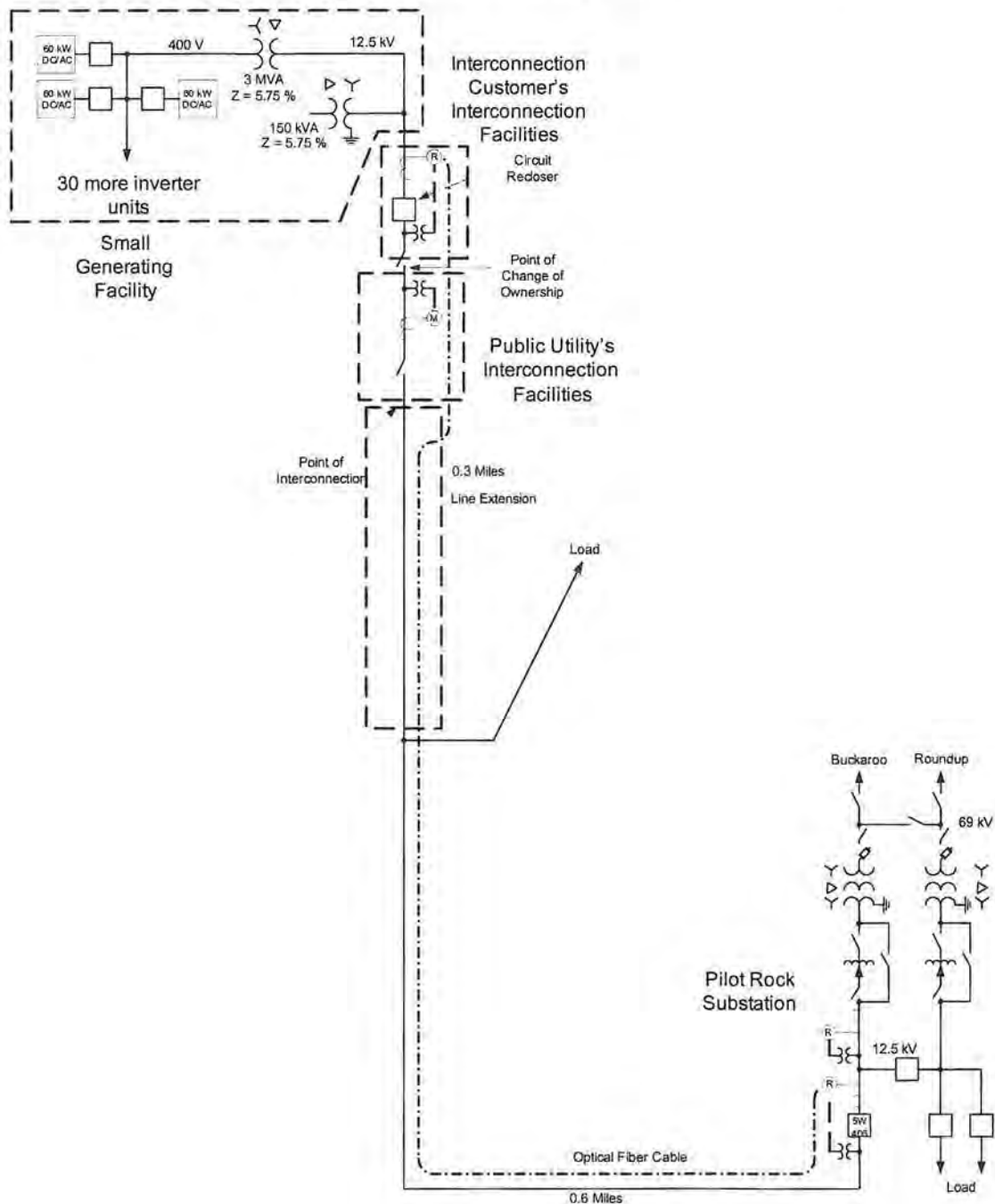

**Interconnection Agreement for Small Generator Facility  
Tier 1, Tier 2, Tier 3 or Tier 4 Interconnection  
(Small Generator Facilities with Electric Nameplate Capacities of 10MW or less)**

**Attachment 3**

**Milestones**

Estimated In-Service Date: May 15, 2017

Critical milestones and responsibility as agreed to by the Parties:

	<b><u>Milestone/Date</u></b>	<b><u>Responsible Party</u></b>
(1)	<u>Execute Agreement and Provide Financial Security / March 15, 2016</u>	<u>Interconnection Customer</u>
(2)	<u>Provide All Required Design Information / May 15, 2016</u>	<u>Interconnection Customer</u>
(3)	<u>Begin Engineering Design / July 15, 2016</u>	<u>Public Utility</u>
(4)	<u>Obtain Property Rights / July 15, 2016</u>	<u>Interconnection Customer</u>
(5)	<u>Complete Engineering Design / December 20, 2016</u>	<u>Public Utility</u>
(6)	<u>Begin Construction / February 18, 2017</u>	<u>Public Utility</u>
(7)	<u>Provide Policy 138 required Test Plan / March 1, 2017</u>	<u>Interconnection Customer</u>
(8)	<u>Complete Construction &amp; Backfeed / April 15, 2017</u>	<u>Both</u>
(9)	<u>Complete Testing &amp; First Synch / May 1, 2017</u>	<u>Both</u>
(10)	<u>Commercial Operations / May 15, 2017</u>	<u>Both</u>

Interconnection Customer is to request Backfeed, 1<sup>st</sup> Sync, and Commercial Operations in writing (email acceptable) prior to the above dates. Public Utility is to approve Interconnection Customer requests without unreasonable delay. The Interconnection Customer will be required to demonstrate the reactive

**Interconnection Agreement for Small Generator Facility  
Tier 1, Tier 2, Tier 3 or Tier 4 Interconnection  
(Small Generator Facilities with Electric Nameplate Capacities of 10MW or less)**

capability of the Small Generating Facility and the voltage control system prior to Commercial Operations.

\* Any design modifications to the Interconnection Customer’s Small Generating Facility after this date requiring updates to the Public Utility’s network model will result in a minimum of 3 months added to all future milestones including Commercial Operation.

\*\*The Public Utility cannot guarantee the availability of a mobile transformer. As such, any delay in the arrival of the mobile transformer could result in delay of the remaining milestones including Commercial Operation.

### Payment Schedule

If Interconnection Customer elects the progress payments option under Article 4.6 of the Interconnection Agreement, there are two potential options for a payment schedule below (please select one). If Interconnection Customer elects progress payment option but an option below is not selected, the Levelized Option will be selected by default. Failure to comply with the selected payment schedule will result in immediate contractual breach, work stoppage, and slip of the milestone schedule above on a day-for-day basis. Interconnection Customer will still be responsible for all costs of the project. Public Utility will conduct initial accounting for the project within thirty (30) days of granting Commercial Operations approval and will determine if a partial refund of project costs is acceptable.

Please select an option:	<input type="checkbox"/>	<input type="checkbox"/>
<u>Funds due no later than</u>	<u>Levelized Option</u>	<u>Stepped Option</u>
March 15, 2016 (or when Interconnection Agreement is executed)	\$10,000	\$10,000
June 1, 2016	\$198,750	\$79,500
August 1, 2016	\$198,750	\$159,000
October 1, 2016	\$198,750	\$238,500
January 1, 2017	\$198,750	\$318,000

**Interconnection Agreement for Small Generator Facility  
Tier 1, Tier 2, Tier 3 or Tier 4 Interconnection  
(Small Generator Facilities with Electric Nameplate Capacities of 10MW or less)**

**Attachment 4**

**Additional Operating Requirements for the Public Utility's  
Transmission System and/or Distribution System and Affected Systems Needed to Support the  
Interconnection Customer's Needs**

The interconnection of the Small Generator Facility is subject to the rules contained within OAR 860 division 82. The interconnection of the Small Generator Facility to the Public Utility's Distribution System shall be subject to, and the Interconnection Customer shall operate the Small Generating Facility in accordance with, the Public Utility's policies governing interconnection of generation facilities to the distribution system entitled "Facility Connection (Interconnection) Requirements for Distribution Systems (34.5 kV and below)" which policy document is available upon request from the Public Utility and is incorporated by this reference as part of the Interconnection Agreement between the Parties. The interconnection of the Small Generator Facility to the Public Utility's Transmission System shall be subject to, and the Interconnection Customer shall operate the Small Generating Facility in accordance with, the Public Utility's policies governing interconnection of generation facilities to the transmission system entitled "Facility Connection (Interconnection) Requirements for Transmission Systems (46 kV and above)" which policy document is available upon request from the Public Utility and is incorporated by this reference as part of the Interconnection Agreement between the Parties. In the event of a conflict between any aspect of this Attachment 4 (including without limitation the Public Utility's policies governing interconnection of generation facilities to the distribution system or the transmission system) and the rules contained in OAR 860, division 82, the rules shall prevail.

Parallel Operation. Interconnection Customer may operate the Generating Facility in parallel with the Public Utility's Transmission System or Distribution System (collectively the "T&D System"), but subject at all times to any operating instructions that the Public Utility's dispatch operators may issue and in accordance with all the provisions of this Interconnection Agreement and Good Utility Practice, and any other conditions imposed by the Public Utility in its sole discretion.

Generating Facility Operation Shall Not Adversely Affect the Public Utility's T&D System. Interconnection Customer shall operate the Generating Facility in such a manner as not to adversely affect the Public Utility's T&D System or any other element of the Public Utility's electrical system. Interconnection Customer's Generating Facility shall deliver not more than the Design Capacity of 1,980 kW. Except as otherwise required by this Interconnection Agreement, Interconnection Customer shall operate the Generating Facility in a manner compatible with the Public Utility's applicable voltage level and fluctuating voltage guidelines, entitled Facility Connection (Interconnection) Requirements for Distribution Systems (34.5 kV and below), as it may be amended or superseded from time to time in the Public Utility's reasonable discretion, at the Point of Interconnection during all times that the Generating Facility is connected and operating in parallel with the Public Utility's T&D System. In its sole discretion, the Public Utility may specify rates of change in Interconnection Customer's deliveries to the Public Utility's T&D System during any start-up of the Generating Facility, during reconnection to the

**Interconnection Agreement for Small Generator Facility  
Tier 1, Tier 2, Tier 3 or Tier 4 Interconnection  
(Small Generator Facilities with Electric Nameplate Capacities of 10MW or less)**

Public Utility's T&D System, and during normal operations to assure that such rates of change are compatible with the operation of the Public Utility's voltage regulation equipment.

Maximum Authorized Power Flow. The Generating Facility shall not be operated in a manner that results in the flow of electric power onto the Public Utility's T&D System during any fifteen (15) minute interval at levels in excess of 2,080 kVA from the Generating Facility. If this provision is violated, the Public Utility may terminate this Interconnection Agreement or lock the Interconnection Customer Disconnect Switch in the open position until such time as: (a) the Public Utility has studied the impact of additional generation on the T&D System (at Interconnection Customer's cost and pursuant to a new study agreement between the Public Utility and Interconnection Customer) and the interconnection has been upgraded (at Interconnection Customer's cost and pursuant to a new or amended Facilities Construction Agreement and a new or amended Interconnection Agreement if deemed necessary by the Public Utility) in any manner necessary to accommodate the additional generation; or (b) the Interconnection Customer has modified the Generating Facility or Interconnection Customer's Interconnection Facilities in such manner as to insure to the Public Utility's satisfaction that the Generating Facility will no longer cause electric power to flow onto the Public Utility's T&D System at a level in excess of 2,080 kVA.

Harmonic Distortion or Voltage Flicker. Notwithstanding the Study Results, upon notice from the Public Utility that operation of the Generating Facility is producing unacceptable harmonic distortions or voltage flicker on the Public Utility's T&D System, Interconnection Customer shall at its sole cost remedy such harmonic distortions or voltage flicker within a reasonable time.

Reactive Power. Interconnection Customer shall at all times control the flow of reactive power between the Generating Facility and the Public Utility's T&D System within limits established by the Public Utility. The Public Utility shall not be obligated to pay Interconnection Customer for any Kvar or Kvar Hours flowing into the Public Utility's T&D System.

Islanding. If at any time during the term of this Interconnection Agreement the interconnection of the Generating Facility to the Public Utility's T&D System results in a risk of electrical islanding, or actual occurrences of electrical islanding, which the Public Utility reasonably concludes are incompatible with Good Utility Practice, the Parties shall (as necessary) study the issue and implement a solution that will eliminate or mitigate the risk of electrical islanding to a level deemed acceptable by the Public Utility. All costs associated with addressing any electrical islanding problems as required by this paragraph shall be paid by the Interconnection Customer, including without limitation any study costs, engineering costs, design costs, or costs to procure, install, operate and/or maintain required interconnection facilities or protective devices.

Voltage Regulation. The Interconnection Customer agrees to operate at a  $\pm 95\%$  leading or lagging power factor. Prior to installation, Interconnection Customer shall provide the Public Utility with written notice of the device and/or operational constraints selected to satisfy this requirement and shall obtain the Public Utility's written approval of such device and/or operational constraints, which approval shall not be unreasonably withheld. In the event Interconnection Customer fails to operate the Generating Facility

**Interconnection Agreement for Small Generator Facility  
Tier 1, Tier 2, Tier 3 or Tier 4 Interconnection  
(Small Generator Facilities with Electric Nameplate Capacities of 10MW or less)**

within the voltage regulation constraints of this requirement, the Public Utility may disconnect the Generating Facility.

Modification of Nominal Operating Voltage Level. By providing Interconnection Customer with a one hundred and eighty (180) day notice, the Public Utility may at its sole discretion change the Public Utility's nominal operating voltage level at the Point of Interconnection. In the event of such change in voltage level Interconnection Customer shall, at Interconnection Customer's sole expense, modify Interconnection Customer's Interconnection Facilities as necessary to accommodate the modified nominal operating voltage level. Interconnection Customer has been informed that initial use of a dual voltage Interconnection Customer may ameliorate the cost of accommodating a change in nominal operating voltage level.

Equipment Failure. Interconnection Customer acknowledges that it is responsible for repair or replacement of Interconnection Customer's primary transformer and for any and all other components of the Generating Facility and the Interconnection Customer's Interconnection Facilities. Interconnection Customer is aware that its inability to timely repair or replace its transformer or any other component of the Generating Facility or Interconnection Customer's Interconnection Facility could result in Interconnection Customer's inability to comply with its responsibilities under this Interconnection Agreement and could lead to disconnection of the Generating Facility from the Public Utility's T&D System and/or termination of this Interconnection Agreement pursuant to the terms of this Interconnection Agreement. Interconnection Customer acknowledges that the risk of this result is born solely by Interconnection Customer and may be substantially ameliorated by Interconnection Customer's elective maintenance of adequate reserve or spare components including but not limited to the Interconnection Customer's primary transformer.

Operation and Maintenance of Facilities Not Owned by the Public Utility. Interconnection Customer shall maintain, test, repair, keep accounts current on, or provide for the proper operation of any and all interconnection facilities, including but not limited to telemetry and communication equipment, not owned by the Public Utility.

Metering and Telemetry Communications Equipment. Notwithstanding any language of OAR 860-082-0070, Public Utility shall not require Interconnection Customer to install a redundant or back-up meter or other telemetry communications equipment. However, Public Utility reserves the right to request that the Oregon Public Utility Commission authorize Public Utility to require Interconnection Customer to be responsible for all reasonable costs associated with redundant metering and communications equipment installed at the Small Generating Facility, upon a determination by Public Utility that such equipment is necessary to maintain compliance with the mandatory reliability standards enforced by the North American Electric Reliability Corporation and the Western Electricity Coordinating Council.

Property Language. Interconnection Customer is required to obtain for the benefit of Public Utility at Interconnection Customer's sole cost and expense all real property rights, including but not limited to fee ownership, easements and/or rights of way, as applicable, for Public Utility owned Facilities using Public

**Interconnection Agreement for Small Generator Facility  
Tier 1, Tier 2, Tier 3 or Tier 4 Interconnection  
(Small Generator Facilities with Electric Nameplate Capacities of 10MW or less)**

Utility's standard forms. Public Utility shall not be obligated to accept any such real property right that does not, at Public Utility's sole discretion, confer sufficient rights to access, operate, construct, modify, maintain, place and remove Public Utility owned Facilities or is otherwise not conveyed using Public Utility's standard forms. Further, all real property on which Public Utility's Facilities are to be located must be environmentally, physically and operationally acceptable to the Public Utility at its sole discretion. Interconnection Customer is responsible for obtaining all permits required by all relevant jurisdictions for the project, including but not limited to, conditional use permits and construction permits; provided however, Public Utility shall obtain, at Interconnection Customer's cost and schedule risk, the permits necessary to construct Public Utility's Facilities that are to be located on real property currently owned or held in fee or right by Public Utility. Except as expressly waived in writing by an authorized officer of Public Utility, all of the foregoing permits and real property rights (conferring rights on real property that is environmentally, physically and operationally acceptable to Public Utility) shall be acquired as provided herein as a condition to Public Utility's contractual obligation to construct or take possession of facilities to be owned by the Public Utility under this Agreement. Public Utility shall have no liability for any project delays or cost overruns caused by delays in acquiring any of the foregoing permits and/or real property rights, whether such delay results from the failure to obtain such permits or rights or the failure of such permits or rights to meet the requirements set forth herein. Further, any completion dates, if any, set forth herein with regard to Public Utility's obligations shall be equitably extended based on the length and impact of any such delays.



**Interconnection Agreement for Small Generator Facility  
Tier 1, Tier 2, Tier 3 or Tier 4 Interconnection  
(Small Generator Facilities with Electric Nameplate Capacities of 10MW or less)**

**Attachment 5**

**Public Utility' s Description of its Upgrades and Best Estimate of Upgrade Costs**

**Distribution Upgrades:** Extend Circuit 5W406 by approximately .3 miles. Install approximately .9 miles of fiber optic cable. Add VTs and circuit metering and modify communications and protection scheme at Pilot Rock substation. Estimated cost is \$602,000.

**Network Upgrades:** The following locations will require the Network Upgrades described below:

- No upgrades

**Interconnection Agreement for Small Generator Facility  
Tier 1, Tier 2, Tier 3 or Tier 4 Interconnection  
(Small Generator Facilities with Electric Nameplate Capacities of 10MW or less)**

**Attachment 6**

**Scope of Work**

**GENERATING FACILITY MODIFICATIONS**

At the Small Generating Facility, a relay will need to be installed that will monitor the voltage magnitude and frequency. If the magnitude or frequency of the voltage is outside of the normal range of operation, the relay will need to disconnect the Small Generating Facility. It is our recommendation that a SEL 351 type relay be installed for this purpose. This relay has six pickup levels with different time delays for both the frequency and magnitude of the voltage to make the relay sensitive to small diversions from nominal but with adequate time delay and also fast reacting for extreme diversions.

The Public Utility will procure, install, test, and own all revenue metering equipment. It is expected the revenue metering instrument transformers will be installed overhead on a pole at the Point of Interconnection. The meter instrument transformer mounting shall conform to Public Utility's construction standards.

The metering will be bidirectional to measure KWH and KVARH quantities for both the generation received and the retail load delivered. The Interconnection Customer may request output from the Public Utility's revenue meters.

Communication equipment will be required to remotely interrogate the meter for generation and billing data via Public Utility's MV90 data acquisition system.

***INTERCONNECTION CUSTOMER WILL BE RESPONSIBLE FOR THE FOLLOWING:***

- Design, procure, install, and own an SEL 351 type relay to monitor the voltage and frequency of the Small Generating Facility.
- Provide professional engineer ("PE") signed and stamped drawings for Interconnection Customer's Small Generating Facility to Public Utility to allow development of required relay settings.
- Install and own a recloser for the Public Utility's SEL 2829 optical transceiver.

***PUBLIC UTILITY WILL BE RESPONSIBLE FOR THE FOLLOWING:***

- Design and communicate to the Interconnection Customer the settings to be programmed into the SEL 351 type relay.
- Own the revenue class instrument transformers required for the interconnection of the Small Generating Facility.
- Procure, install, and own two (2) meters are required for retail load Customer Net Gen reverse feed.
- Own the revenue class instrument transformers required for the interconnection of the Small Generating Facility.
- Design, procure, install, and own of Ethernet (preferred) or a cell phone to be designed as part

**Interconnection Agreement for Small Generator Facility  
Tier 1, Tier 2, Tier 3 or Tier 4 Interconnection  
(Small Generator Facilities with Electric Nameplate Capacities of 10MW or less)**

of the meter and utilized to allow for remote interrogation of the Small Generating Facility.

- Design, procure, install, and own one (1) metering panel.
- Design, procure, install, and own of the required meter, test switches and secondary meter wire needed to interconnect the Small Generating Facility.
- Design, procure, install, and own the required meter, test switches and secondary meter wire needed to interconnect the Small Generating Facility.
- Design, procure and install all required communication fiber patch panel, fiber modem, and related communication equipment needed to connect to new 48-fiber, single mode, ADSS cable and to Interconnection Customer's recloser/equipment.

**DISTRIBUTION LINE REQUIREMENTS**

The following outlines the design, procurement, installation, and ownership of equipment for the distribution line.

***INTERCONNECTION CUSTOMER WILL BE RESPONSIBLE FOR THE FOLLOWING:***

- Obtain required right of way for newly required tap line from City Feeder to Small Generating Facility.

***PUBLIC UTILITY WILL BE RESPONSIBLE FOR THE FOLLOWING:***

- Design, install, and own 0.3 miles of 4/0 AAC primary conductors and one 4/0AAC neutral conductor from the Point of Interconnection (proposed facility point #090961) to the Point of Change of Ownership.
- Design, install, and own a gang operated switch and primary metering units.
- Procure and install one (1) span of overhead primary conductors from the primary metering pole to Interconnection Customer's pole. The termination of this conductor at the Small Generating Facility will serve as the Point of Change of Ownership.
- Replace the tap changing controller on R-816 with a controller capable of handling reverse power flow.
- Design, procure, install, and own new 48-fiber, single mode, ADSS cable from Small Generating Facility to Pilot Rock substation.

**PILOT ROCK SUBSTATION**

The following outlines the design, procurement, installation, testing and ownership of equipment for Public Utility's Distribution Circuit.

***PUBLIC UTILITY WILL BE RESPONSIBLE FOR THE FOLLOWING:***

- Procure, install, and own three (3) 12.5 kV VT's.
- Design, procure, and install required steel support structures and associated foundations for all new equipment if required.
- Design, procure, and install a one (1) new PC-611 panel.
- Design, procure, and install a one (1) new PII11 annunciator panel.

**Interconnection Agreement for Small Generator Facility  
Tier 1, Tier 2, Tier 3 or Tier 4 Interconnection  
(Small Generator Facilities with Electric Nameplate Capacities of 10MW or less)**

- Design, procure, and install two (2) new PC 510 transformer metering panels.
- Design, procure and install all required communication fiber patch panel, fiber modem, and related communication equipment needed to connect to new 48-fiber, single mode, ADSS cable and to Interconnection Customer's recloser/equipment.
- Design, procure and install a fiber-optic channel to send direct transfer trip to the Interconnection Customer's collector site recloser using mirrored bits.

JUN 20 2016

## AGREEMENT TO AMEND INTERCONNECTION AGREEMENT FOR SMALL GENERATOR FACILITY

TRANSMISSION SERVICES  
PACIFICORP

This **Agreement To Amend Interconnection Agreement for Small Generator Facility** ("Agreement") is made and entered into this 20<sup>th</sup> day of June, 2016, by and between PacifiCorp, an Oregon corporation (the "Public Utility") and Sunthurst Energy, LLC (Q666), an Oregon Limited Liability Company (the "Interconnection Customer"). Transmission Provider and Interconnection Customer may be referred to as a "Party" or collectively as the "Parties."

## RECITALS

JUN 20 2016

**WHEREAS**, Transmission Provider and Interconnection Customer have entered into a Generator Interconnection Agreement ("Interconnection Agreement"), dated March 14, 2016;

**WHEREAS**, Public Utility and Interconnection Customer have mutually agreed to amend one or more appendices, attachments, and/or exhibits to the Interconnection Agreement; and

**WHEREAS**, Article 8.2 of the Interconnection Agreement states that the Parties may mutually agree to amend this Interconnection Agreement by a written instrument duly executed by both parties;

**NOW, THEREFORE**, in consideration of and subject to the mutual covenants contained herein, it is agreed:

- 1.0 The Parties acknowledge and mutually agree that the following attachment will substitute in its entirety for the same attachment in the Interconnection Agreement:
  - Attachment 3
- 2.0 Service under the Interconnection Agreement with the amended attachment will commence only upon execution by both Parties.
- 3.0 The Interconnection Agreement, with the substitute attachment shall constitute the entire agreement between the Parties.
- 4.0 TO THE FULLEST EXTENT PERMITTED BY LAW, EACH OF THE PARTIES HERETO WAIVES ANY RIGHT IT MAY HAVE TO A TRIAL BY JURY IN RESPECT OF LITIGATION DIRECTLY OR INDIRECTLY ARISING OUT OF, UNDER OR IN CONNECTION WITH THIS AGREEMENT. EACH PARTY FURTHER WAIVES ANY RIGHT TO CONSOLIDATE, OR TO REQUEST THE CONSOLIDATION OF, ANY ACTION IN WHICH A JURY TRIAL HAS BEEN WAIVED WITH ANY OTHER ACTION IN WHICH A JURY TRIAL CANNOT BE OR HAS NOT BEEN WAIVED.
- 5.0 All other provisions of the Interconnection Agreement will continue to apply.

IN WITNESS WHEREOF, the Parties have executed this Agreement in duplicate originals, each of which shall constitute and be an original effective Agreement between the Parties.

PacifiCorp

By: *[Signature]*

Title: VP, Transmission

Date: 6/20/16

20 REV

Sunthurst Energy, LLC (Q666)

By: *[Signature]*

Title: Principal

Date: 6.15.16

**Interconnection Agreement for Small Generator Facility  
Tier 1, Tier 2, Tier 3 or Tier 4 Interconnection  
(Small Generator Facilities with Electric Nameplate Capacities of 10MW or less)**

**Attachment 3**

**Milestones**

Estimated In-Service Date: September 15, 2017

11/14 2 0 REC

Critical milestones and responsibility as agreed to by the Parties:

	<b><u>Milestone/Date</u></b>	<b><u>Responsible Party</u></b>
(1)	<u>Execute Agreement and Provide \$10,000 deposit</u> <u>March 15, 2016</u>	<u>Interconnection Customer</u>
(2)	<u>Provide All Required Design Information</u> <u>October 15, 2016</u>	<u>Interconnection Customer</u>
(3)	<u>Begin Engineering Design</u> <u>November 15, 2016</u>	<u>Public Utility</u>
(4)	<u>Obtain Property Rights</u> <u>November 15, 2016</u>	<u>Interconnection Customer</u>
(5)	<u>Complete Engineering Design</u> <u>April 20, 2017</u>	<u>Public Utility</u>
(6)	<u>Begin Construction</u> <u>June 18, 2017</u>	<u>Public Utility</u>
(7)	<u>Provide Policy 138 required Test Plan</u> <u>July 1, 2017</u>	<u>Interconnection Customer</u>
(8)	<u>Complete Construction &amp; Backfeed</u> <u>August 15, 2017</u>	<u>Both</u>
(9)	<u>Complete Testing &amp; First Sync</u> <u>September 1, 2017</u>	<u>Both</u>
(10)	<u>Commercial Operations</u> <u>September 15, 2017</u>	<u>Both</u>

Interconnection Customer is to request Backfeed, 1<sup>st</sup> Sync, and Commercial Operations in writing (email acceptable) prior to the above dates. Public Utility is to approve Interconnection Customer requests without unreasonable delay. The Interconnection Customer will be required to demonstrate the reactive

**Interconnection Agreement for Small Generator Facility  
 Tier 1, Tier 2, Tier 3 or Tier 4 Interconnection  
 (Small Generator Facilities with Electric Nameplate Capacities of 10MW or less)**

capability of the Small Generating Facility and the voltage control system prior to Commercial Operations.

\* Any design modifications to the Interconnection Customer’s Small Generating Facility after this date requiring updates to the Public Utility’s network model will result in a minimum of 3 months added to all future milestones including Commercial Operation.

\*\*The Public Utility cannot guarantee the availability of a mobile transformer. As such, any delay in the arrival of the mobile transformer could result in delay of the remaining milestones including Commercial Operation.

### Payment Schedule

If Interconnection Customer elects the progress payments option under Article 4.6 of the Interconnection Agreement, there are two potential options for a payment schedule below (please select one). If Interconnection Customer elects progress payment option but an option below is not selected, the Levelized Option will be selected by default. Failure to comply with the selected payment schedule will result in immediate contractual breach, work stoppage, and slip of the milestone schedule above on a day-for-day basis. Interconnection Customer will still be responsible for all costs of the project. Public Utility will conduct initial accounting for the project within thirty (30) days of granting Commercial Operations approval and will determine if a partial refund of project costs is acceptable.

Please select an option:	<input type="checkbox"/>	<input type="checkbox"/>
	<u>Levelized Option</u>	<u>Stepped Option</u>
<u>Funds due no later than</u> March 15, 2016 (or when Interconnection Agreement is executed)	\$10,000	\$10,000 - Paid
October 1, 2016	\$198,750	\$79,500
December 1, 2016	\$198,750	\$159,000
February 1, 2017	\$198,750	\$238,500
May 1, 2017	\$198,750	\$318,000



RECEIVED

OCT 11 2016

TRANSMISSION SERVICES  
PACIFICORP

**AGREEMENT TO AMEND INTERCONNECTION AGREEMENT FOR SMALL GENERATOR FACILITY**

This **Agreement To Amend Interconnection Agreement for Small Generator Facility** ("Agreement") is made and entered into this 11<sup>th</sup> day of October, 2016, by and between PacifiCorp, an Oregon corporation (the "Public Utility") and Sunthurst Energy, LLC (Q666), an Oregon Limited Liability Company (the "Interconnection Customer"). Transmission Provider and Interconnection Customer may be referred to as a "Party" or collectively as the "Parties."

**RECITALS**

**WHEREAS**, Transmission Provider and Interconnection Customer have entered into a Generator Interconnection Agreement ("Interconnection Agreement"), dated March 14, 2016;

**WHEREAS**, Public Utility and Interconnection Customer have mutually agreed to amend one or more appendices, attachments, and/or exhibits to the Interconnection Agreement; and

**WHEREAS**, Article 8.2 of the Interconnection Agreement states that the Parties may mutually agree to amend this Interconnection Agreement by a written instrument duly executed by both parties;

**NOW, THEREFORE**, in consideration of and subject to the mutual covenants contained herein, it is agreed:

- 1.0 The Parties acknowledge and mutually agree that the following attachment will substitute in its entirety for the same attachment in the Interconnection Agreement:
  - Attachment 3.
- 2.0 Service under the Interconnection Agreement with the amended attachment will commence only upon execution by both Parties.
- 3.0 The Interconnection Agreement, with the substitute attachment shall constitute the entire agreement between the Parties.
- 4.0 TO THE FULLEST EXTENT PERMITTED BY LAW, EACH OF THE PARTIES HERETO WAIVES ANY RIGHT IT MAY HAVE TO A TRIAL BY JURY IN RESPECT OF LITIGATION DIRECTLY OR INDIRECTLY ARISING OUT OF, UNDER OR IN CONNECTION WITH THIS AGREEMENT. EACH PARTY FURTHER WAIVES ANY RIGHT TO CONSOLIDATE, OR TO REQUEST THE CONSOLIDATION OF, ANY ACTION IN WHICH A JURY TRIAL HAS BEEN WAIVED WITH ANY OTHER ACTION IN WHICH A JURY TRIAL CANNOT BE OR HAS NOT BEEN WAIVED.
- 5.0 All other provisions of the Interconnection Agreement will continue to apply.

IN WITNESS WHEREOF, the Parties have executed this Agreement in duplicate originals, each of which shall constitute and be an original effective Agreement between the Parties.

PacifiCorp

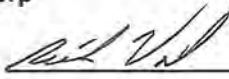
By: 

Title: VP, Transmission

Date: 10/11/16

Sunthurst Energy, LLC (Q666)

By: 

Title: OWNER

Date: 10.4.16

**Interconnection Agreement for Small Generator Facility  
Tier 1, Tier 2, Tier 3 or Tier 4 Interconnection  
(Small Generator Facilities with Electric Nameplate Capacities of 10MW or less)**

**Attachment 3**

**Milestones**

Estimated In-Service Date: September 30, 2018

Critical milestones and responsibility as agreed to by the Parties:

	<b><u>Milestone/Date</u></b>	<b><u>Responsible Party</u></b>
(1)	<u>Execute Agreement and Provide \$10,000 deposit March 15, 2016</u>	<u>Interconnection Customer</u>
(2)	<u>Provide All Required Design Information October 15, 2016</u>	<u>Interconnection Customer</u>
(3)	<u>Begin Engineering Design November 15, 2017</u>	<u>Public Utility</u>
(4)	<u>Obtain Property Rights November 15, 2017</u>	<u>Interconnection Customer</u>
(5)	<u>Complete Engineering Design April 20, 2018</u>	<u>Public Utility</u>
(6)	<u>Begin Construction June 18, 2018</u>	<u>Public Utility</u>
(7)	<u>Provide Policy 138 required Test Plan July 1, 2018</u>	<u>Interconnection Customer</u>
(8)	<u>Complete Construction &amp; Backfeed September 1, 2018</u>	<u>Both</u>
(9)	<u>Complete Testing &amp; First Sync September 15, 2018</u>	<u>Both</u>
(10)	<u>Commercial Operations September 30, 2018</u>	<u>Both</u>

Interconnection Customer is to request Backfeed, 1<sup>st</sup> Sync, and Commercial Operations in writing (email acceptable) prior to the above dates. Public Utility is to approve Interconnection Customer requests without unreasonable delay. The Interconnection Customer will be required to demonstrate the reactive

**Interconnection Agreement for Small Generator Facility  
Tier 1, Tier 2, Tier 3 or Tier 4 Interconnection  
(Small Generator Facilities with Electric Nameplate Capacities of 10MW or less)**

capability of the Small Generating Facility and the voltage control system prior to Commercial Operations.

\* Any design modifications to the Interconnection Customer’s Small Generating Facility after this date requiring updates to the Public Utility’s network model will result in a minimum of 3 months added to all future milestones including Commercial Operation.

\*\*The Public Utility cannot guarantee the availability of a mobile transformer. As such, any delay in the arrival of the mobile transformer could result in delay of the remaining milestones including Commercial Operation.

### Payment Schedule

If Interconnection Customer elects the progress payments option under Article 4.6 of the Interconnection Agreement, there are two potential options for a payment schedule below (please select one). If Interconnection Customer elects progress payment option but an option below is not selected, the Levelized Option will be selected by default. Failure to comply with the selected payment schedule will result in immediate contractual breach, work stoppage, and slip of the milestone schedule above on a day-for-day basis. Interconnection Customer will still be responsible for all costs of the project. Public Utility will conduct initial accounting for the project within thirty (30) days of granting Commercial Operations approval and will determine if a partial refund of project costs is acceptable.

Please select an option:	<input type="checkbox"/>	<input checked="" type="checkbox"/>
<u>Funds due no later than</u> March 15, 2016 (or when Interconnection Agreement is executed)	<u>Levelized Option</u>	<u>Stepped Option</u>
	\$10,000	\$10,000 - Paid
October 1, 2017	\$198,750	\$79,500
December 1, 2017	\$198,750	\$159,000
February 1, 2018	\$198,750	\$238,500
May 1, 2018	\$198,750	\$318,000

NOV 21 2017

TRANSMISSION SERVICES  
PACIFICORP

## AGREEMENT TO AMEND INTERCONNECTION AGREEMENT FOR SMALL GENERATOR FACILITY

This Agreement To Amend Interconnection Agreement for Small Generator Facility ("Agreement") is made and entered into this 21<sup>st</sup> day of November, 2017, by and between PacifiCorp, an Oregon corporation (the "Public Utility") and Sunthurst Energy, LLC (Q666), an Oregon limited liability company (the "Interconnection Customer"). Transmission Provider and Interconnection Customer may be referred to as a "Party" or collectively as the "Parties."

## RECITALS

**WHEREAS**, Transmission Provider and Interconnection Customer have entered into a Generator Interconnection Agreement ("Interconnection Agreement"), dated March 14, 2016, and amended as of June 20, 2016, and October 11, 2016;

**WHEREAS**, Public Utility and Interconnection Customer have mutually agreed to amend one or more appendices, attachments, and/or exhibits to the Interconnection Agreement; and

**WHEREAS**, Article 8.2 of the Interconnection Agreement states that the Parties may mutually agree to amend this Interconnection Agreement by a written instrument duly executed by both parties;

**NOW, THEREFORE**, in consideration of and subject to the mutual covenants contained herein, it is agreed:

- 1.0 The Parties acknowledge and mutually agree that the following attachment will substitute in its entirety the same attachment in the Interconnection Agreement:
  - Attachment 3.
- 2.0 Service under the Interconnection Agreement with the amended attachment will commence only upon execution by both Parties.
- 3.0 The Interconnection Agreement, with the attached substitute attachments shall constitute the entire agreement between the Parties.
- 4.0 TO THE FULLEST EXTENT PERMITTED BY LAW, EACH OF THE PARTIES HERETO WAIVES ANY RIGHT IT MAY HAVE TO A TRIAL BY JURY IN RESPECT OF LITIGATION DIRECTLY OR INDIRECTLY ARISING OUT OF, UNDER OR IN CONNECTION WITH THIS AGREEMENT. EACH PARTY FURTHER WAIVES ANY RIGHT TO CONSOLIDATE, OR TO REQUEST THE CONSOLIDATION OF, ANY ACTION IN WHICH A JURY TRIAL HAS BEEN WAIVED WITH ANY OTHER ACTION IN WHICH A JURY TRIAL CANNOT BE OR HAS NOT BEEN WAIVED.
- 5.0 All other provisions of the Interconnection Agreement will continue to apply.

IN WITNESS WHEREOF, the Parties have executed this Agreement in duplicate originals, each of which shall constitute and be an original effective Agreement between the Parties.

**PacifiCorp**

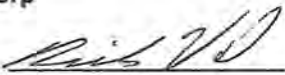
By:   
Rick Vail  
Title: VP, Transmission  
Date: 11/27/17

**Sunthurst Energy, LLC (Q666)**

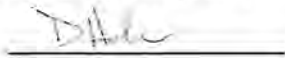
By:   
Title: Owner  
Date: 11/21/17

**Interconnection Agreement for Small Generator Facility  
Tier 1, Tier 2, Tier 3 or Tier 4 Interconnection  
(Small Generator Facilities with Electric Nameplate Capacities of 10MW or less)**

**Attachment 3**

**Milestones**

Estimated In-Service Date: June 30, 2019

Critical milestones and responsibility as agreed to by the Parties:

	<b>Milestone/Date</b>	<b>Responsible Party</b>
(1)	<u>Execute Agreement and Provide \$10,000 deposit March 15, 2016</u>	<u>Interconnection Customer</u>
(2)	<u>Provide All Required Design Information July 12, 2018</u>	<u>Interconnection Customer</u>
(3)	<u>Begin Engineering Design July 12, 2018</u>	<u>Public Utility</u>
(4)	<u>Obtain Property Rights September 1, 2018</u>	<u>Interconnection Customer</u>
(5)	<u>Complete Engineering Design December 13, 2018</u>	<u>Public Utility</u>
(6)	<u>Begin Construction April 1, 2019</u>	<u>Public Utility</u>
(7)	<u>Provide Policy 138 required Test Plan May 1, 2019</u>	<u>Interconnection Customer</u>
(8)	<u>Complete Construction &amp; Backfeed June 1, 2019</u>	<u>Both</u>
(9)	<u>Complete Testing &amp; First Sync June 25, 2019</u>	<u>Both</u>
(10)	<u>Commercial Operations June 30, 2019</u>	<u>Both</u>

Interconnection Customer is to request Backfeed, 1<sup>st</sup> Sync, and Commercial Operations in writing (email acceptable) prior to the above dates. Public Utility is to approve Interconnection Customer requests without unreasonable delay. The Interconnection Customer will be required to demonstrate the reactive

**Interconnection Agreement for Small Generator Facility  
Tier 1, Tier 2, Tier 3 or Tier 4 Interconnection  
(Small Generator Facilities with Electric Nameplate Capacities of 10MW or less)**

capability of the Small Generating Facility and the voltage control system prior to Commercial Operations.

\* Any design modifications to the Interconnection Customer’s Small Generating Facility after this date requiring updates to the Public Utility’s network model will result in a minimum of 3 months added to all future milestones including Commercial Operation.

\*\*The Public Utility cannot guarantee the availability of a mobile transformer. As such, any delay in the arrival of the mobile transformer could result in delay of the remaining milestones including Commercial Operation.

### Payment Schedule

If Interconnection Customer elects the progress payments option under Article 4.6 of the Interconnection Agreement, there are two potential options for a payment schedule below (please select one). If Interconnection Customer elects progress payment option but an option below is not selected, the Levelized Option will be selected by default. Failure to comply with the selected payment schedule will result in immediate contractual breach, work stoppage, and slip of the milestone schedule above on a day-for-day basis. Interconnection Customer will still be responsible for all costs of the project. Public Utility will conduct initial accounting for the project within thirty (30) days of granting Commercial Operations approval and will determine if a partial refund of project costs is acceptable.

Please select an option:	<input type="checkbox"/>	<input checked="" type="checkbox"/>
<u>Funds due no later than</u> March 15, 2016 (or when Interconnection Agreement is executed)	<u>Levelized Option</u>	<u>Stepped Option</u>
July 1, 2018	\$10,000	\$10,000 - Paid
August 1, 2018	\$198,750	\$79,500
October 1, 2018	\$198,750	\$159,000
December 1, 2018	\$198,750	\$238,500
		\$318,000



**AGREEMENT TO AMEND INTERCONNECTION AGREEMENT FOR SMALL GENERATOR FACILITY**

This **Agreement To Amend Interconnection Agreement for Small Generator Facility** ("Agreement") is made and entered into this 6<sup>th</sup> day of November, 2018, by and between PacifiCorp, an Oregon corporation (the "Public Utility") and Sunthurst Energy, LLC (Q666), an Oregon limited liability company (the "Interconnection Customer"). Transmission Provider and Interconnection Customer may be referred to as a "Party" or collectively as the "Parties."

**RECITALS**

**WHEREAS**, Transmission Provider and Interconnection Customer have entered into a Generator Interconnection Agreement ("Interconnection Agreement"), dated March 14, 2016, and amended as of June 20, 2016, October 11, 2016, and November 21, 2017;

**WHEREAS**, Public Utility and Interconnection Customer have mutually agreed to amend one or more appendices, attachments, and/or exhibits to the Interconnection Agreement; and

**WHEREAS**, Article 8.2 of the Interconnection Agreement states that the Parties may mutually agree to amend this Interconnection Agreement by a written instrument duly executed by both parties;

**NOW, THEREFORE**, in consideration of and subject to the mutual covenants contained herein, it is agreed:

- 1.0 The Parties acknowledge and mutually agree that the following attached attachment will substitute in its entirety the same attachment in the Interconnection Agreement:
  - Attachment 3
- 2.0 Service under the Interconnection Agreement with the amended attachment will commence only upon execution by both Parties.
- 3.0 The Interconnection Agreement, with the attached substitute attachments shall constitute the entire agreement between the Parties.
- 4.0 TO THE FULLEST EXTENT PERMITTED BY LAW, EACH OF THE PARTIES HERETO WAIVES ANY RIGHT IT MAY HAVE TO A TRIAL BY JURY IN RESPECT OF LITIGATION DIRECTLY OR INDIRECTLY ARISING OUT OF, UNDER OR IN CONNECTION WITH THIS AGREEMENT. EACH PARTY FURTHER WAIVES ANY RIGHT TO CONSOLIDATE, OR TO REQUEST THE CONSOLIDATION OF, ANY ACTION IN WHICH A JURY TRIAL HAS BEEN WAIVED WITH ANY OTHER ACTION IN WHICH A JURY TRIAL CANNOT BE OR HAS NOT BEEN WAIVED.
- 5.0 All other provisions of the Interconnection Agreement will continue to apply.

IN WITNESS WHEREOF, the Parties have executed this Agreement in duplicate originals, each of which shall constitute and be an original effective Agreement between the Parties.

**PacifiCorp**

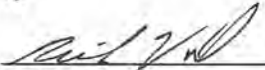
By:   
Rick Vail  
Title: VP, Transmission  
Date: 11/6/18

**Sunthurst Energy, LLC (Q666)**

By:   
Title: Owner  
Date: 11/6/18

### Attachment 3

#### Milestones

Estimated In-Service Date: December 31, 2019

Critical milestones and responsibility as agreed to by the Parties:

	<b>Milestone/Date</b>	<b>Responsible Party</b>
(1)	<u>Execute Agreement and Provide \$10,000 deposit</u> <u>March 15, 2016</u>	<u>Interconnection Customer</u>
(2)	<u>Provide All Required Design Information</u> <u>July 12, 2018</u>	<u>Interconnection Customer</u>
(3)	<u>Begin Engineering Design</u> <u>February 1, 2019</u>	<u>Public Utility</u>
(4)	<u>Obtain Property Rights</u> <u>April 1, 2019</u>	<u>Interconnection Customer</u>
(5)	<u>Complete Engineering Design</u> <u>July 15, 2019</u>	<u>Public Utility</u>
(6)	<u>Begin Construction</u> <u>September 1, 2019</u>	<u>Public Utility</u>
(7)	<u>Provide Policy 138 required Test Plan</u> <u>November 1, 2019</u>	<u>Interconnection Customer</u>
(8)	<u>Complete Construction &amp; Backfeed</u> <u>December 1, 2019</u>	<u>Both</u>
(9)	<u>Complete Testing &amp; First Sync</u> <u>December 25, 2019</u>	<u>Both</u>
(10)	<u>Commercial Operations</u> <u>December 31, 2019</u>	<u>Both</u>

Interconnection Customer is to request Backfeed, 1<sup>st</sup> Sync, and Commercial Operations in writing (email acceptable) prior to the above dates. Public Utility is to approve Interconnection Customer requests without unreasonable delay. The Interconnection Customer will be required to demonstrate the reactive

capability of the Small Generating Facility and the voltage control system prior to Commercial Operations.

\* Any design modifications to the Interconnection Customer’s Small Generating Facility after this date requiring updates to the Public Utility’s network model will result in a minimum of 3 months added to all future milestones including Commercial Operation.

\*\*The Public Utility cannot guarantee the availability of a mobile transformer. As such, any delay in the arrival of the mobile transformer could result in delay of the remaining milestones including Commercial Operation.

### Payment Schedule

If Interconnection Customer elects the progress payments option under Article 4.6 of the Interconnection Agreement, there are two potential options for a payment schedule below (please select one). If Interconnection Customer elects progress payment option but an option below is not selected, the Levelized Option will be selected by default. Failure to comply with the selected payment schedule will result in immediate contractual breach, work stoppage, and slip of the milestone schedule above on a day-for-day basis. Interconnection Customer will still be responsible for all costs of the project. Public Utility will conduct initial accounting for the project within thirty (30) days of granting Commercial Operations approval and will determine if a partial refund of project costs is acceptable.

Please select an option:	<input type="checkbox"/>	<input type="checkbox"/>
<u>Funds due no later than</u> March 15, 2016 (or when Interconnection Agreement is executed)	<u>Levelized Option</u>	<u>Stepped Option</u>
July 1, 2018	\$10,000	\$10,000 - Paid
July 1, 2018	\$143,100	\$79,500 - Paid
April 1, 2019	\$143,100	\$53,500
June 1, 2019	\$143,100	\$159,000
August 1, 2019	\$143,100	\$238,500
October 15, 2019	\$143,100	\$318,000

## AGREEMENT TO AMEND INTERCONNECTION AGREEMENT FOR SMALL GENERATOR FACILITY

This **Agreement To Amend Interconnection Agreement for Small Generator Facility** (“Agreement”) is made and entered into this 17th day of March, 2022, by and between PacifiCorp, an Oregon corporation (the “Public Utility”) and Sunthurst Energy, LLC, an Oregon limited liability company (the “Interconnection Customer”). Public Utility and Interconnection Customer may be referred to as a “Party” or collectively as the “Parties.”

### RECITALS

**WHEREAS**, Public Utility and Interconnection Customer have entered into a Generator Interconnection Agreement (“Interconnection Agreement”), dated March 14, 2016;

**WHEREAS**, Public Utility and Interconnection Customer have mutually agreed to amend one or more appendices, attachments, and/or exhibits to the Interconnection Agreement; and

**WHEREAS**, Article 8.2 of the Interconnection Agreement states that the Parties may mutually agree to amend this Interconnection Agreement by a written instrument duly executed by both parties;

**NOW, THEREFORE**, in consideration of and subject to the mutual covenants contained herein, it is agreed:

- 1.0 The Parties acknowledge and mutually agree that the following attached attachments will substitute in their entirety the same attachments in the Interconnection Agreement:
  - Attachment 1
  - Attachment 3
  - Attachment 5
  - Attachment 6
- 2.0 Service under the Interconnection Agreement with the amended attachments will commence only upon execution by both Parties.
- 3.0 The Interconnection Agreement, with the attached substitute attachments shall constitute the entire agreement between the Parties.
- 4.0 All other provisions of the Interconnection Agreement will continue to apply.

**IN WITNESS WHEREOF**, the Parties have executed this Agreement in duplicate originals, each of which shall constitute and be an original effective Agreement between the Parties.

**PacifiCorp**

**By:** Rick Vail Digitally signed by  
Rick Vail  
Date: 2022.03.17  
08:17:52 -07'00'

**Title:** VP, Transmission

**Date:** 03/17/2022

**Sunthurst Energy, LLC**

**By:** D Hale

**Title:** Manager

**Date:** 3/15/2022

**Interconnection Agreement for Small Generator Facility  
Tier 1, Tier 2, Tier 3 or Tier 4 Interconnection  
(Small Generator Facilities with Electric Nameplate Capacities of 10MW or less)**

**Attachment 1**

**Description of Interconnection Facilities  
And Metering Equipment Operated or Maintained by the Public Utility**

Small Generating Facility: A 1.98 MW solar generating facility consisting of thirty-three (33) SMA MLX-60 60 kW inverters, connected to one (1) generation step up transformer (3 MVA, 5.75%), and one (1) 150 kVA grounding bank with an impedance of 5.75%, connected to Public Utility's Distribution System in Umatilla County, Oregon. See Attachment 2.

Interconnection Customer Interconnection Facilities: A short, 12.5 kV tie connecting the step-up transformer to the Interconnection Customer owned recloser and relay. Interconnection Customer will also own a gang-operated disconnect switch that Public Utility can access. See Attachment 2.

Public Utility's Interconnection Facilities: A short run of distribution circuit connected to a 12.5 kV disconnect switch, bi-directional revenue metering facilities and fiber optic cable equipment necessary for transfer-trip between the Small Generating Facility and Pilot Rock substation. See Attachment 2.

Estimated cost of Public Utility's Interconnection Facilities directly assigned to Interconnection Customer: \$139,000

Estimated Annual Operation and Maintenance Cost of Public Utility's Interconnection Facilities: \$1,500. Interconnection Customer shall be responsible for Public Utility's actual cost for maintenance of the Public Utility's Interconnection Facilities.

Point of Interconnection: The point where the Public Utility's Interconnection Facilities connect to the Public Utility's 12.5 kV distribution circuit 5W406 out of Pilot Rock substation. See Attachment 2.

Point of Change of Ownership: The point where the Interconnection Customer's Interconnection Facilities connect to the Public Utility's Interconnection Facilities. See Attachment 2.

**Interconnection Agreement for Small Generator Facility  
Tier 1, Tier 2, Tier 3 or Tier 4 Interconnection  
(Small Generator Facilities with Electric Nameplate Capacities of 10MW or less)**

**Attachment 3**

**Milestones**

Estimated In-Service Date: December 31, 2022

Critical milestones and responsibility as agreed to by the Parties:

	<b>Milestone/Date</b>	<b>Responsible Party</b>
(1)	<u>Execute Agreement and Provide \$10,000 deposit</u> <u>March 15, 2016</u>	<u>Interconnection Customer</u>
(2)	<u>Retail Service Request Established</u> <u>March 18, 2022</u>	<u>Interconnection Customer</u>
(3)	<u>*Initial Design Information Provided</u> <u>March 18, 2022</u>	<u>Interconnection Customer</u>
(4)	<u>Begin Engineering Design</u> <u>April 4, 2022</u>	<u>Public Utility</u>
(5)	<u>Obtain Property Rights</u> <u>May 6, 2022</u>	<u>Interconnection Customer</u>
(6)	<u>*Final design information provided</u> <u>June 10, 2022</u>	<u>Interconnection Customer</u>
(7)	<u>Property/Permits/RoW procured</u> <u>July 1, 2022</u>	<u>Public Utility</u>
(8)	<u>Complete Engineering Design</u> <u>September 9, 2022</u>	<u>Public Utility</u>
(9)	<u>Begin Construction</u> <u>October 17, 2022</u>	<u>Public Utility</u>
(10)	<u>Provide Policy 138 required Test &amp; Maintenance Plans</u> <u>November 4, 2022</u>	<u>Interconnection Customer</u>
(11)	<u>Complete Construction</u> <u>December 16, 2022</u>	<u>Both</u>



**Interconnection Agreement for Small Generator Facility  
Tier 1, Tier 2, Tier 3 or Tier 4 Interconnection  
(Small Generator Facilities with Electric Nameplate Capacities of 10MW or less)**

- |      |  |                                 |
|------|--|---------------------------------|
| (12) | <u>Commissioning Complete</u><br><u>December 28, 2022</u>                        | <u>Public Utility</u>           |
| (13) | <u>Backfeed</u><br><u>December 29, 2022</u>                                      | <u>Interconnection Customer</u> |
| (14) | <u>Initial synchronization and generator testing</u><br><u>December 30, 2022</u> | <u>Interconnection Customer</u> |
| (15) | <u>Commercial Operations</u><br><u>December 31, 2022</u>                         | <u>Both</u>                     |

Interconnection Customer is to request Backfeed, 1<sup>st</sup> Sync, and Commercial Operations in writing (email acceptable) prior to the above dates. Public Utility is to approve Interconnection Customer requests without unreasonable delay. The Interconnection Customer will be required to demonstrate the reactive capability of the Small Generating Facility and the voltage control system prior to Commercial Operations.

\*Interconnection Customer initial design package shall include final generating facility location, inverter/turbine selection, basic protection package, tie line route and collector system locations and data as applicable. Interconnection Customer final design package shall include PE stamped issued for construction (“IFC”) drawings for generating facility, collector substation, tie line as well as an updated PSS/e model and updated WECC approved model, electromagnetic transient (“EMT”) model and a detailed short circuit model of its generation system using the ASPEN OneLine short circuit simulation program as applicable. The WECC model parameters must be adjusted to reflect the plant’s actual anticipated performance. The plant controller must be included in the model. If there is to be coordination between facilities or a master VAR controller, this must be included in the detailed WECC dynamic model, as well as in the PSS/e user-written model.

## Payment Schedule

If Interconnection Customer elects the progress payments option under Article 4.6 of the Interconnection Agreement, there are two potential options for a payment schedule below (please select one). If Interconnection Customer elects progress payment option but an option below is not selected, the Levelized Option will be selected by default. Failure to comply with the selected payment schedule will result in immediate contractual breach, work stoppage, and slip of the milestone schedule above on a day-for-day basis. Interconnection Customer will still be responsible for all costs of the project. Public Utility will conduct initial accounting for the project within thirty (30) days of granting Commercial Operations approval and will determine if a partial refund of project costs is acceptable.

Please select an option:

Funds due no later than Stepped Option



**Interconnection Agreement for Small Generator Facility  
Tier 1, Tier 2, Tier 3 or Tier 4 Interconnection  
(Small Generator Facilities with Electric Nameplate Capacities of 10MW or less)**

March 15, 2016 (or when Interconnection Agreement is executed)	\$10,000 - Paid
July 1, 2018	\$79,500 - Paid
May 1, 2022	\$200,000
July 1, 2022	\$282,500



**Interconnection Agreement for Small Generator Facility  
Tier 1, Tier 2, Tier 3 or Tier 4 Interconnection  
(Small Generator Facilities with Electric Nameplate Capacities of 10MW or less)**

**Attachment 5**

**Public Utility' s Description of its Upgrades and Best Estimate of Upgrade Costs**

**Distribution Upgrades:** Install approximately 0.9 miles of fiber optic cable. Add VTs and circuit metering and modify communications and protection scheme at Pilot Rock substation. Estimated cost is \$433,000.

**Network Upgrades:** The following locations will require the Network Upgrades described below:

- No upgrades

**Interconnection Agreement for Small Generator Facility  
Tier 1, Tier 2, Tier 3 or Tier 4 Interconnection  
(Small Generator Facilities with Electric Nameplate Capacities of 10MW or less)**

**Attachment 6**

**Scope of Work**

**GENERATING FACILITY MODIFICATIONS**

At the Small Generating Facility, a relay will need to be installed that will monitor the voltage magnitude and frequency. If the magnitude or frequency of the voltage is outside of the normal range of operation, the relay will need to disconnect the Small Generating Facility. It is our recommendation that a SEL 351 type relay be installed for this purpose. This relay has six pickup levels with different time delays for both the frequency and magnitude of the voltage to make the relay sensitive to small diversions from nominal but with adequate time delay and also fast reacting for extreme diversions.

The Public Utility will procure, install, test, and own all revenue metering equipment. It is expected the revenue metering instrument transformers will be installed overhead on a pole at the Point of Interconnection. The meter instrument transformer mounting shall conform to Public Utility's construction standards.

The metering will be bidirectional to measure KWH and KVARH quantities for both the generation received and the retail load delivered. The Interconnection Customer may request output from the Public Utility's revenue meters.

Communication equipment will be required to remotely interrogate the meter for generation and billing data via Public Utility's MV90 data acquisition system.

***INTERCONNECTION CUSTOMER WILL BE RESPONSIBLE FOR THE FOLLOWING:***

- Procure all necessary permits, lands, rights of way and easements required for the construction and continued maintenance of the Q0666 Small Generator Facility and collector substation.
- Design, procure, construct, own and maintain the Interconnection Customer's Small Generator Facility and associated collector substation.
- Design the Small Generating Facility with reactive power capabilities necessary to operate within the full power factor range of 0.95 leading to 0.95 lagging as measured at the Point of Interconnection. The reactive compensation must be designed such that the discreet switching of all reactive devices (if required by the Interconnection Customer) does not cause step voltage changes greater than +/-3% on the Public Utility's system.
- Operate the Small Generating Facility under constant power factor mode with a unity power factor setting unless specifically requested otherwise by the Public Utility. The Small Generating Facility is expressly forbidden from actively participating in voltage regulation of the Public Utilities system without written request or authorization from the Public Utility.
- Operate the Small Generating Facility so minimum power quality requirements in PacifiCorp's Engineering Handbook section 1C are met, the standards are available at <https://www.pacificpower.net/about/power-quality-standards.html>. Requirements specified in the System Impact Study that exceed requirements in the Engineering Handbook section 1C power

**Interconnection Agreement for Small Generator Facility  
Tier 1, Tier 2, Tier 3 or Tier 4 Interconnection  
(Small Generator Facilities with Electric Nameplate Capacities of 10MW or less)**

quality standards shall apply.

- As per NERC standard VAR-001-1, the Public Utility is required to specify voltage or reactive power schedule at the Point of interconnection. Under normal conditions, the Public Utility's system should not supply reactive power to the Small Generating Facility.
- Install a transformer that will hold the phase to neutral voltages within limits when the Small Generator Facility is isolated with the Public Utility's local system until the generation disconnects such as a wye-delta grounding transformer. Please note that the transformer thus far proposed by the Interconnection Customer is not acceptable to the Public Utility.
- Design, procure, install, and own an SEL 351 type relay to monitor the voltage and frequency of the Small Generating Facility.
- Provide the Public Utility second level password control of the Interconnection Customer's relay to ensure no settings changes can be made to the relay without Public Utility review and approval.
- Provide professional engineer ("PE") signed and stamped drawings for Interconnection Customer's Small Generating Facility to Public Utility to allow development of required relay settings.
- Install and own a recloser for the Public Utility's SEL 2829 optical transceiver.
- Arrange for and provide permanent retail service for power that will flow from the Public Utility's system when the Small Generator Facility is not generating. This arrangement must be in place prior to approval for backfeed.
- Provide any construction or backup retail service necessary for the Project.
- Provide the Public Utility a Professional Engineer ("PE") approved maintenance plan for all Interconnection Customer Interconnection facilities prior to commencement of generation activities.

***PUBLIC UTILITY WILL BE RESPONSIBLE FOR THE FOLLOWING:***

- Design and communicate to the Interconnection Customer the settings to be programmed into the SEL 351 type relay.
- Own the revenue class instrument transformers required for the interconnection of the Small Generating Facility.
- Procure, install, and own two (2) meters are required for retail load Customer Net Gen reverse feed.
- Own the revenue class instrument transformers required for the interconnection of the Small Generating Facility.
- Design, procure, install, and own of Ethernet (preferred) or a cell phone to be designed as part of the meter and utilized to allow for remote interrogation of the Small Generating Facility.
- Design, procure, install, and own one (1) metering panel.
- Design, procure, install, and own of the required meter, test switches and secondary meter wire needed to interconnect the Small Generating Facility.
- Design, procure, install, and own the required meter, test switches and secondary meter wire needed to interconnect the Small Generating Facility.
- Design, procure and install all required communication fiber patch panel, fiber modem, and

**Interconnection Agreement for Small Generator Facility  
Tier 1, Tier 2, Tier 3 or Tier 4 Interconnection  
(Small Generator Facilities with Electric Nameplate Capacities of 10MW or less)**

related communication equipment needed to connect to new 48-fiber, single mode, ADSS cable and to Interconnection Customer's recloser/equipment.

**DISTRIBUTION LINE REQUIREMENTS**

The following outlines the design, procurement, installation, and ownership of equipment for the distribution line.

***INTERCONNECTION CUSTOMER WILL BE RESPONSIBLE FOR THE FOLLOWING:***

- Obtain required right of way for newly required tap line from the Public Utility's existing facilities to the Point of Interconnection.

***PUBLIC UTILITY WILL BE RESPONSIBLE FOR THE FOLLOWING:***

- Design, install, and own 3 spans of 4/0 AAC primary conductors and one 4/0AAC neutral conductor from the Public Utility's existing facilities (proposed facility point #090961) to the Point of Change of Ownership.
- Design, install, and own a gang operated switch and primary metering units.
- Procure and install one (1) span of overhead primary conductors from the primary metering pole to Interconnection Customer's pole. The termination of this conductor at the Small Generating Facility will serve as the Point of Change of Ownership.
- Replace the tap changing controller on R-816 with a controller capable of handling reverse power flow.
- Design, procure, install, and own new 48-fiber, single mode, ADSS cable from Small Generating Facility to Pilot Rock substation.

**PILOT ROCK SUBSTATION**

The following outlines the design, procurement, installation, testing and ownership of equipment for Public Utility's Distribution Circuit.

***PUBLIC UTILITY WILL BE RESPONSIBLE FOR THE FOLLOWING:***

- Procure, install, and own three (3) 12.5 kV VT's.
- Design, procure, and install required steel support structures and associated foundations for all new equipment if required.
- Design, procure, and install a one (1) new PC-611 panel.
- Design, procure, and install two (2) new PC 510 transformer metering panels.
- Design, procure and install all required communication fiber patch panel, fiber modem, and related communication equipment needed to connect to new 48-fiber, single mode, ADSS cable and to Interconnection Customer's recloser/equipment.
- Design, procure and install a fiber-optic channel to send direct transfer trip to the Interconnection Customer's collector site recloser using mirrored bits.

## AGREEMENT TO AMEND INTERCONNECTION AGREEMENT FOR SMALL GENERATOR FACILITY

This **Agreement To Amend Interconnection Agreement for Small Generator Facility** (“Agreement”) is made and entered into this 15th day of August, 2022, by and between PacifiCorp, an Oregon corporation (the “Public Utility”) and Pilot Rock Solar 1, LLC, an Oregon limited liability company (the “Interconnection Customer”). Public Utility and Interconnection Customer may be referred to as a “Party” or collectively as the “Parties.”

### RECITALS

**WHEREAS**, Public Utility and Interconnection Customer have entered into a Generator Interconnection Agreement (“Interconnection Agreement”), dated March 14, 2016;

**WHEREAS**, Public Utility and Interconnection Customer have mutually agreed to amend one or more attachments and articles to the Interconnection Agreement; and

**WHEREAS**, consistent with Article 5.1 of the Interconnection Agreement, by notice to Public Utility on July 14, 2022, Sunthurst Energy, LLC assigned and transferred the Interconnection Agreement to Pilot Rock Solar 1, LLC;

**WHEREAS**, Article 8.2 of the Interconnection Agreement states that the Parties may mutually agree to amend this Interconnection Agreement by a written instrument duly executed by both parties;

**NOW, THEREFORE**, in consideration of and subject to the mutual covenants contained herein, it is agreed:

- 1.0 The Parties acknowledge and mutually agree that the following attached article and attachments will substitute in their entirety the same article and attachment in the Interconnection Agreement:
  - **Article 9.3**
  - **Attachment 3**
  - **Attachment 6**
- 2.0 Service under the Interconnection Agreement with the amended article and attachments will commence only upon execution by both Parties.
- 3.0 The Interconnection Agreement, with the attached substitute attachments shall constitute the entire agreement between the Parties.
- 4.0 All other provisions of the Interconnection Agreement will continue to apply.

**IN WITNESS WHEREOF**, the Parties have executed this Agreement in duplicate originals, each of which shall constitute and be an original effective Agreement between the Parties.

**PacifiCorp**

**By:** Rick Vail Digitally signed by Rick Vail  
Date: 2022.08.15  
21:42:44 -07'00'

**Title:** VP, Transmission

**Date:** 08/15/2022

**Pilot Rock Solar 1, LLC**

**By:** D Hale

**Title:** Manager

**Date:** 8/12/2022



**Interconnection Agreement for Small Generator Facility  
Tier 1, Tier 2, Tier 3 or Tier 4 Interconnection  
(Small Generator Facilities with Electric Nameplate Capacities of 10MW or less)**

This Interconnection Agreement for Small Generator Facility (“Agreement”) is made and entered into this \_\_\_ day of \_\_\_\_\_ by and between Pilot Rock Solar 1, LLC, a Limited Liability Company organized and existing under the laws of the State of Oregon, (“Interconnection Customer”) and PacifiCorp, a Corporation, existing under the laws of the State of Oregon, (“Public Utility”). The Interconnection Customer and Public Utility may be referred to hereinafter singly as a “Party” or collectively as the “Parties.”

**Recitals:**

**Whereas**, the Interconnection Customer is proposing to develop a Small Generator Facility, or to add generating capacity to an existing Small Generator Facility, consistent with the Application completed on May 7, 2015;

**Whereas**, the Interconnection Customer desires to interconnect the Small Generator Facility with Public Utility’s Transmission System and/or Distribution System (“T&D System”) in the State of Oregon; and

**Whereas**, the interconnection of the Small Generator Facility and the Public Utility’s T&D System is subject to the jurisdiction of the Public Utility Commission of Oregon (“Commission”) and governed by OPUC Rule OAR 860, Division 082 (the “Rule”).

**Now, therefore**, in consideration of and subject to the mutual covenants contained herein, the Parties agree as follows:

**Article 1.      Scope and Limitations of Agreement**

**1.1      Scope**

This Agreement establishes the standard terms and conditions under which the Small Generator Facility with a Nameplate Capacity of no more than 10 megawatts (“MW”) will interconnect to, and operate in Parallel with, the Public Utility’s T&D System. The Commission has approved standard terms and conditions governing this class of interconnection. Any additions, deletions or changes to the standard terms and conditions of interconnection approved by the Commission must be mutually agreed by the Parties or, if required by the Rule, any such changes must be approved by the Commission. Terms with initial capitalization, when used in this Agreement, shall have the meanings given in the Rule. This Agreement shall be construed where possible to be consistent with the Rules; to the extent this Agreement conflicts with the Rule, the Rule shall take precedence.

**1.2      No Agreement Regarding Power Purchase, Transmission, or Delivery**

This Agreement does not constitute an agreement to purchase, transmit, or deliver any power or capacity from the interconnected Small Generating Facility nor does it constitute

**Interconnection Agreement for Small Generator Facility  
Tier 1, Tier 2, Tier 3 or Tier 4 Interconnection  
(Small Generator Facilities with Electric Nameplate Capacities of 10MW or less)**

Either Party will have the right to make a unilateral filing with the Commission to modify this Agreement. This reservation of rights provision will include but is not limited to modifications with respect to any rates terms and conditions, charges, classification of service, rule or regulation under tariff rates or any applicable State or Federal law or regulation. Each Party shall have the right to protest any such filing and to participate fully in any proceeding before the Commission in which such modifications may be considered.

**Article 9. Notices and Records**

**9.1 General**

Unless otherwise provided in this Agreement, any written notice, demand, or request required or authorized in connection with this Agreement shall be deemed properly given if delivered in person, delivered by recognized national courier service, or sent by first class mail, postage prepaid, to the person specified below:

**9.2 Records**

The Public Utility will maintain a record of all Interconnection Agreements and related Form attachments for as long as the interconnection is in place as required by OAR 860-082-0065. The Public Utility will provide a copy of these records to the Interconnection Customer within 15 Business Days if a request is made in writing.

**If to the Interconnection Customer:**

Interconnection Customer: Pilot Rock Solar 1, LLC

Attention: Daniel Hale

Address: 43682 SW Brower Lane

City: Pendleton State: Oregon Zip: 97801

Phone: 323-480-3835 Fax: 323-782-0760 Email: PM1@pilotrocksolar.com

**If to Public Utility:**

Public Utility: PacifiCorp

Attention: Transmission Service

Address: 825 NE Multnomah, Suite 550

City: Portland State: Oregon Zip: 97232

Phone: 503-813-6077 Fax: 503-813-6893

**9.3 Billing and Payment**

Billings and payments shall be sent to the addresses set out below: (complete if different than article 9.2 above)

**Interconnection Agreement for Small Generator Facility  
Tier 1, Tier 2, Tier 3 or Tier 4 Interconnection  
(Small Generator Facilities with Electric Nameplate Capacities of 10MW or less)**

**If to the Interconnection Customer**

Interconnection Customer: Pilot Rock Solar 1, LLC  
Attention: Daniel Hale  
Address: P.O. Box 549  
City: Stanfield State: Oregon Zip: 97875  
Phone: 323-480-3835 Fax: 323-782-0760 E-mail: PM1@pilotrocksolar.com

**If to Public Utility**

Public Utility: PacifiCorp Transmission  
Attention: Central Cashiers Office  
Address: P.O. Box 2757  
City: Portland State: OR Zip: 97208-2757

**9.4 Designated Operating Representative**

The Parties will designate operating representatives to conduct the communications which may be necessary or convenient for the administration of the operations provisions of this Agreement. This person will also serve as the point of contact with respect to operations and maintenance of the Party's facilities (complete if different than article 9.2 above)

**Interconnection Customer's Operating Representative:** Pilot Rock Solar 1, LLC

Attention: Daniel Hale  
Address: P.O. Box 549  
City: Stanfield State: Oregon Zip: 97875  
Phone: 323-480-3835 Fax: 323-782-0760  
E-Mail: PM1@pilotrocksolar.com

**Public Utility's Operating Representative:** PacifiCorp

Attention: Grid Operations  
Address: 9915 S.E. Ankeny Street  
City: Portland State: OR Zip: 97216  
Phone: 503-251-5197 Fax: 503-251-5228

**9.5 Changes to the Notice Information**

Either Party may change this notice information by giving five Business Days written notice prior to the effective date of the change.

**Interconnection Agreement for Small Generator Facility  
Tier 1, Tier 2, Tier 3 or Tier 4 Interconnection  
(Small Generator Facilities with Electric Nameplate Capacities of 10MW or less)**

**Attachment 3**

**Milestones**

Estimated In-Service Date: May 25, 2023

Critical milestones and responsibility as agreed to by the Parties:

	<b>Milestone/Date</b>	<b>Responsible Party</b>
(1)	<u>Execute Agreement and Provide \$10,000 deposit</u> <u>March 15, 2016</u>	<u>Interconnection Customer</u>
(2)	<u>Retail Service Request Established</u> <u>March 18, 2022</u>	<u>Interconnection Customer</u>
(3)	<u>*Initial Design Information Provided</u> <u>March 18, 2022</u>	<u>Interconnection Customer</u>
(4)	<u>Begin Engineering Design</u> <u>April 4, 2022</u>	<u>Public Utility</u>
(5)	<u>Obtain Property Rights</u> <u>May 6, 2022</u>	<u>Interconnection Customer</u>
(6)	<u>*Final design information provided</u> <u>October 3, 2022</u>	<u>Interconnection Customer</u>
(7)	<u>Property/Permits/RoW procured</u> <u>October 28, 2022</u>	<u>Public Utility</u>
(8)	<u>Complete Engineering Design</u> <u>November 11, 2022</u>	<u>Public Utility</u>
(9)	<u>Begin Construction</u> <u>February 6, 2023</u>	<u>Public Utility</u>
(10)	<u>Provide Policy 138 required Test &amp; Maintenance Plans</u> <u>April 7, 2023</u>	<u>Interconnection Customer</u>
(11)	<u>Complete Construction</u> <u>May 5, 2023</u>	<u>Both</u>

**Interconnection Agreement for Small Generator Facility  
Tier 1, Tier 2, Tier 3 or Tier 4 Interconnection  
(Small Generator Facilities with Electric Nameplate Capacities of 10MW or less)**

- |      |   |                                 |
|------|---|---------------------------------|
| (12) | <u>Commissioning Complete</u><br><u>May 19, 2023</u>                        | <u>Public Utility</u>           |
| (13) | <u>Backfeed</u><br><u>May 22, 2023</u>                                      | <u>Interconnection Customer</u> |
| (14) | <u>Initial synchronization and generator testing</u><br><u>May 24, 2023</u> | <u>Interconnection Customer</u> |
| (15) | <u>Commercial Operations</u><br><u>May 25, 2023</u>                         | <u>Both</u>                     |

Interconnection Customer is to request Backfeed, 1<sup>st</sup> Sync, and Commercial Operations in writing (email acceptable) prior to the above dates. Public Utility is to approve Interconnection Customer requests without unreasonable delay. The Interconnection Customer will be required to demonstrate the reactive capability of the Small Generating Facility and the voltage control system prior to Commercial Operations.

\*Interconnection Customer initial design package shall include final generating facility location, inverter/turbine selection, basic protection package, tie line route and collector system locations and data as applicable. Interconnection Customer final design package shall include PE stamped issued for construction (“IFC”) drawings for generating facility, collector substation, tie line as well as an updated PSS/e model and updated WECC approved model, electromagnetic transient (“EMT”) model and a detailed short circuit model of its generation system using the ASPEN OneLine short circuit simulation program as applicable. The WECC model parameters must be adjusted to reflect the plant’s actual anticipated performance. The plant controller must be included in the model. If there is to be coordination between facilities or a master VAR controller, this must be included in the detailed WECC dynamic model, as well as in the PSS/e user-written model.

## Payment Schedule

If Interconnection Customer elects the progress payments option under Article 4.6 of the Interconnection Agreement, there are two potential options for a payment schedule below (please select one). If Interconnection Customer elects progress payment option but an option below is not selected, the Levelized Option will be selected by default. Failure to comply with the selected payment schedule will result in immediate contractual breach, work stoppage, and slip of the milestone schedule above on a day-for-day basis. Interconnection Customer will still be responsible for all costs of the project. Public Utility will conduct initial accounting for the project within thirty (30) days of granting Commercial Operations approval and will determine if a partial refund of project costs is acceptable.

Please select an option:

Funds due no later than Stepped Option



**Interconnection Agreement for Small Generator Facility  
Tier 1, Tier 2, Tier 3 or Tier 4 Interconnection  
(Small Generator Facilities with Electric Nameplate Capacities of 10MW or less)**

March 15, 2016 (or when Interconnection Agreement is executed)	\$10,000 - Paid
July 1, 2018	\$79,500 - Paid
September 1, 2022	\$20,000
November 1, 2022	\$180,000
March 1, 2023	\$282,500

**Interconnection Agreement for Small Generator Facility  
Tier 1, Tier 2, Tier 3 or Tier 4 Interconnection  
(Small Generator Facilities with Electric Nameplate Capacities of 10MW or less)**

**Attachment 6**

**Scope of Work**

**GENERATING FACILITY MODIFICATIONS**

At the Small Generating Facility, a relay will need to be installed that will monitor the voltage magnitude and frequency. If the magnitude or frequency of the voltage is outside of the normal range of operation, the relay will need to disconnect the Small Generating Facility. It is our recommendation that a SEL 351 type relay be installed for this purpose. This relay has six pickup levels with different time delays for both the frequency and magnitude of the voltage to make the relay sensitive to small diversions from nominal but with adequate time delay and also fast reacting for extreme diversions.

The Public Utility will procure, install, test, and own all revenue metering equipment. It is expected the revenue metering instrument transformers will be installed overhead on a pole at the Point of Interconnection. The meter instrument transformer mounting shall conform to Public Utility's construction standards.

The metering will be bidirectional to measure KWH and KVARH quantities for both the generation received and the retail load delivered. The Interconnection Customer may request output from the Public Utility's revenue meters.

Communication equipment will be required to remotely interrogate the meter for generation and billing data via Public Utility's MV90 data acquisition system.

***INTERCONNECTION CUSTOMER WILL BE RESPONSIBLE FOR THE FOLLOWING:***

- Procure all necessary permits, lands, rights of way and easements required for the construction and continued maintenance of the Q0666 Small Generator Facility and collector substation.
- Design, procure, construct, own and maintain the Interconnection Customer's Small Generator Facility and associated collector substation.
- Design the Small Generating Facility with reactive power capabilities necessary to operate within the full power factor range of 0.95 leading to 0.95 lagging as measured at the Point of Interconnection. The reactive compensation must be designed such that the discreet switching of all reactive devices (if required by the Interconnection Customer) does not cause step voltage changes greater than +/-3% on the Public Utility's system.
- Operate the Small Generating Facility under constant power factor mode with a unity power factor setting unless specifically requested otherwise by the Public Utility. The Small Generating Facility is expressly forbidden from actively participating in voltage regulation of the Public Utilities system without written request or authorization from the Public Utility.
- Operate the Small Generating Facility so minimum power quality requirements in PacifiCorp's Engineering Handbook section 1C are met, the standards are available at <https://www.pacificpower.net/about/power-quality-standards.html>. Requirements specified in the System Impact Study that exceed requirements in the Engineering Handbook section 1C power

**Interconnection Agreement for Small Generator Facility  
Tier 1, Tier 2, Tier 3 or Tier 4 Interconnection  
(Small Generator Facilities with Electric Nameplate Capacities of 10MW or less)**

quality standards shall apply.

- As per NERC standard VAR-001-1, the Public Utility is required to specify voltage or reactive power schedule at the Point of interconnection. Under normal conditions, the Public Utility's system should not supply reactive power to the Small Generating Facility.
- Install a transformer that will hold the phase to neutral voltages within limits when the Small Generator Facility is isolated with the Public Utility's local system until the generation disconnects such as a wye-delta grounding transformer. Please note that the transformer thus far proposed by the Interconnection Customer is not acceptable to the Public Utility.
- Design, procure, install, and own an SEL 351 type relay to monitor the voltage and frequency of the Small Generating Facility.
- Provide the Public Utility second level password control of the Interconnection Customer's relay to ensure no settings changes can be made to the relay without Public Utility review and approval.
- Provide professional engineer ("PE") signed and stamped drawings for Interconnection Customer's Small Generating Facility to Public Utility to allow development of required relay settings.
- Install and own a recloser for the Public Utility's SEL 2829 optical transceiver.
- Arrange for and provide permanent retail service for power that will flow from the Public Utility's system when the Small Generator Facility is not generating. This arrangement must be in place prior to approval for backfeed.
- Provide any construction or backup retail service necessary for the Project.
- Provide the Public Utility a Professional Engineer ("PE") approved maintenance plan for all Interconnection Customer Interconnection Facilities prior to commencement of generation activities.

***PUBLIC UTILITY WILL BE RESPONSIBLE FOR THE FOLLOWING:***

- Design and communicate to the Interconnection Customer the settings to be programmed into the SEL 351 type relay.
- Own the revenue class instrument transformers required for the interconnection of the Small Generating Facility.
- Procure, install, own and maintain, at the Public Utility's expense, two (2) (primary and secondary) SCADA capable meters required for retail load Customer Net Gen reverse feed.
- Procure install, own and maintain, at the Public Utility's expense, communications equipment required to facilitate the acquisition of standard SCADA points to be communicated to the Public Utility's System Operations Centers.
- Own the revenue class instrument transformers required for the interconnection of the Small Generating Facility.
- Design, procure, install, and own of Ethernet (preferred) or a cell phone to be designed as part of the meter and utilized to allow for remote interrogation of the Small Generating Facility.
- Design, procure, install, and own one (1) metering panel.
- Design, procure, install, and own of the required meter, test switches and secondary meter wire needed to interconnect the Small Generating Facility.



**Interconnection Agreement for Small Generator Facility  
Tier 1, Tier 2, Tier 3 or Tier 4 Interconnection  
(Small Generator Facilities with Electric Nameplate Capacities of 10MW or less)**

- Design, procure, install, and own the required meter, test switches and secondary meter wire needed to interconnect the Small Generating Facility.
- Design, procure and install all required communication fiber patch panel, fiber modem, and related communication equipment needed to connect to new 48-fiber, single mode, ADSS cable and to Interconnection Customer's recloser/equipment.

**DISTRIBUTION LINE REQUIREMENTS**

The following outlines the design, procurement, installation, and ownership of equipment for the distribution line.

***INTERCONNECTION CUSTOMER WILL BE RESPONSIBLE FOR THE FOLLOWING:***

- Obtain required right of way for newly required tap line from the Public Utility's existing facilities to the Point of Interconnection.

***PUBLIC UTILITY WILL BE RESPONSIBLE FOR THE FOLLOWING:***

- Design, install, and own 3 spans of 4/0 AAC primary conductors and one 4/0AAC neutral conductor from the Public Utility's existing facilities (proposed facility point #090961) to the Point of Change of Ownership.
- Design, install, and own a gang operated switch and primary metering units.
- Procure and install one (1) span of overhead primary conductors from the primary metering pole to Interconnection Customer's pole. The termination of this conductor at the Small Generating Facility will serve as the Point of Change of Ownership.
- Replace the tap changing controller on R-816 with a controller capable of handling reverse power flow.
- Design, procure, install, and own new 48-fiber, single mode, ADSS cable from Small Generating Facility to Pilot Rock substation.

**PILOT ROCK SUBSTATION**

The following outlines the design, procurement, installation, testing and ownership of equipment for Public Utility's Distribution Circuit.

***PUBLIC UTILITY WILL BE RESPONSIBLE FOR THE FOLLOWING:***

- Procure, install, and own three (3) 12.5 kV VT's.
- Design, procure, and install required steel support structures and associated foundations for all new equipment if required.
- Design, procure, and install a one (1) new PC-611 panel.
- Design, procure, and install two (2) new PC 510 transformer metering panels.
- Design, procure and install all required communication fiber patch panel, fiber modem, and related communication equipment needed to connect to new 48-fiber, single mode, ADSS cable and to Interconnection Customer's recloser/equipment.



**Interconnection Agreement for Small Generator Facility  
Tier 1, Tier 2, Tier 3 or Tier 4 Interconnection  
(Small Generator Facilities with Electric Nameplate Capacities of 10MW or less)**

- Design, procure and install a fiber-optic channel to send direct transfer trip to the Interconnection Customer's collector site recloser using mirrored bits.

## AGREEMENT TO AMEND INTERCONNECTION AGREEMENT FOR SMALL GENERATOR FACILITY

This **Agreement To Amend Interconnection Agreement for Small Generator Facility** (“Agreement”) is made and entered into this \_\_\_\_\_ day of \_\_\_\_\_, 2023, by and between PacifiCorp, an Oregon corporation (the “Public Utility”) and Pilot Rock Solar 1, LLC (Q0666), an Oregon limited liability company (the “Interconnection Customer”). Public Utility and Interconnection Customer may be referred to as a “Party” or collectively as the “Parties.”

### RECITALS

**WHEREAS**, Public Utility and Interconnection Customer have entered into a Generator Interconnection Agreement (“Interconnection Agreement”), dated March 14, 2016 with the sixth amendment dated August 15, 2022;

**WHEREAS**, Public Utility and Interconnection Customer have mutually agreed to amend one or more attachments to the Interconnection Agreement; and

**WHEREAS**, Article 8.2 of the Interconnection Agreement states that the Parties may mutually agree to amend this Interconnection Agreement by a written instrument duly executed by both parties;

**NOW, THEREFORE**, in consideration of and subject to the mutual covenants contained herein, it is agreed:

- 1.0 The Parties acknowledge and mutually agree that the following attached attachment will substitute in its entirety the same attachment in the Interconnection Agreement:
  - Attachment 3
- 2.0 Service under the Interconnection Agreement with the amended attachment will commence only upon execution by both Parties.
- 3.0 The Interconnection Agreement, with the attached substitute attachment shall constitute the entire agreement between the Parties.
- 4.0 All other provisions of the Interconnection Agreement will continue to apply.

**IN WITNESS WHEREOF**, the Parties have executed this Agreement in duplicate originals, each of which shall constitute and be an original effective Agreement between the Parties.

**PacifiCorp**

**By:** \_\_\_\_\_

**Title:** \_\_\_\_\_

**Date:** \_\_\_\_\_

**Pilot Rock Solar 1, LLC (Q0666)**

**By:** \_\_\_\_\_

**Title:** \_\_\_\_\_

**Date:** \_\_\_\_\_

### Attachment 3

#### Milestones

Estimated In-Service Date: September 30, 2025

Critical milestones and responsibility as agreed to by the Parties:

	<b>Milestone/Date</b>	<b>Responsible Party</b>
(1)	<u>Execute Agreement and Provide \$10,000 deposit</u> March 15, 2016 - completed	<u>Interconnection Customer</u>
(2)	<u>Retail Service Request Established</u> January 15, 2024	<u>Interconnection Customer</u>
(3)	<u>*Initial Design Information Provided</u> January 15, 2024	<u>Interconnection Customer</u>
(4)	<u>Begin Engineering Design</u> March 4, 2024	<u>Public Utility</u>
(5)	<u>Obtain Property Rights</u> May 6, 2024	<u>Interconnection Customer</u>
(6)	<u>*Final design information provided</u> October 3, 2024	<u>Interconnection Customer</u>
(7)	<u>Property/Permits/RoW procured</u> October 28, 2024	<u>Public Utility</u>
(8)	<u>Complete Engineering Design</u> November 11, 2024	<u>Public Utility</u>
(9)	<u>Begin Construction</u> January 2, 2025	<u>Public Utility</u>
(10)	<u>Provide Policy 138 required Test &amp; Maintenance Plans</u> August 7, 2025	<u>Interconnection Customer</u>
(11)	<u>Complete Construction</u> September 5, 2025	<u>Both</u>

- |      |  |                                 |
|------|--|---------------------------------|
| (12) | <u>Commissioning Complete</u><br>September 19, 2025                        | <u>Public Utility</u>           |
| (13) | <u>Backfeed</u><br>September 22, 2025                                      | <u>Interconnection Customer</u> |
| (14) | <u>Initial synchronization and generator testing</u><br>September 24, 2025 | <u>Interconnection Customer</u> |
| (15) | <u>Commercial Operations</u><br>September 30, 2025                         | <u>Both</u>                     |

Interconnection Customer is to request Backfeed, 1<sup>st</sup> Sync, and Commercial Operations in writing (email acceptable) prior to the above dates. Public Utility is to approve Interconnection Customer requests without unreasonable delay. The Interconnection Customer will be required to demonstrate the reactive capability of the Small Generating Facility and the voltage control system prior to Commercial Operations.

\*Interconnection Customer initial design package shall include final generating facility location, inverter/turbine selection, basic protection package, tie line route and collector system locations and data as applicable. Interconnection Customer final design package shall include PE stamped issued for construction (“IFC”) drawings for generating facility, collector substation, tie line as well as an updated PSS/e model and updated WECC approved model, electromagnetic transient (“EMT”) model and a detailed short circuit model of its generation system using the ASPEN OneLine short circuit simulation program as applicable. The WECC model parameters must be adjusted to reflect the plant’s actual anticipated performance. The plant controller must be included in the model. If there is to be coordination between facilities or a master VAR controller, this must be included in the detailed WECC dynamic model, as well as in the PSS/e user-written model.

## Payment Schedule

If Interconnection Customer elects the progress payments option under Article 4.6 of the Interconnection Agreement, there are two potential options for a payment schedule below (please select one). If Interconnection Customer elects progress payment option but an option below is not selected, the Levelized Option will be selected by default. Failure to comply with the selected payment schedule will result in immediate contractual breach, work stoppage, and slip of the milestone schedule above on a day-for-day basis. Interconnection Customer will still be responsible for all costs of the project. Public Utility will conduct initial accounting for the project within thirty (30) days of granting Commercial Operations approval and will determine if a partial refund of project costs is acceptable.

Please select an option:

Funds due no later than                      Stepped Option

March 15, 2016 (or when Interconnection Agreement is executed)	\$10,000 - Paid
July 1, 2018	\$79,500 - Paid
January 2, 2024	\$200,000
July 2, 2024	\$282,500

## AGREEMENT TO AMEND INTERCONNECTION AGREEMENT FOR SMALL GENERATOR FACILITY

This **Agreement To Amend Interconnection Agreement for Small Generator Facility** (“Agreement”) is made and entered into this 22nd day of May, 2023, by and between PacifiCorp, an Oregon corporation (the “Public Utility”) and Pilot Rock Solar 1, LLC (Q0666), an Oregon limited liability company (the “Interconnection Customer”). Public Utility and Interconnection Customer may be referred to as a “Party” or collectively as the “Parties.”

### RECITALS

**WHEREAS**, Public Utility and Interconnection Customer have entered into a Generator Interconnection Agreement (“Interconnection Agreement”), dated March 14, 2016 with the sixth amendment dated August 15, 2022;

**WHEREAS**, Public Utility and Interconnection Customer have mutually agreed to amend one or more attachments to the Interconnection Agreement; and

**WHEREAS**, Article 8.2 of the Interconnection Agreement states that the Parties may mutually agree to amend this Interconnection Agreement by a written instrument duly executed by both parties;

**NOW, THEREFORE**, in consideration of and subject to the mutual covenants contained herein, it is agreed:

- 1.0 The Parties acknowledge and mutually agree that the following attached attachment will substitute in its entirety the same attachment in the Interconnection Agreement:
  - Attachment 3
- 2.0 Service under the Interconnection Agreement with the amended attachment will commence only upon execution by both Parties.
- 3.0 The Interconnection Agreement, with the attached substitute attachment shall constitute the entire agreement between the Parties.
- 4.0 All other provisions of the Interconnection Agreement will continue to apply.



**IN WITNESS WHEREOF**, the Parties have executed this Agreement in duplicate originals, each of which shall constitute and be an original effective Agreement between the Parties.

**PacifiCorp**

**By:** Kristopher J Bremer  
Kristopher J Bremer  
2023.05.22  
19:12:52 -07'00'

**Title:** Dir., Transmission Svcs

**Date:** 05/22/2023

**Pilot Rock Solar 1, LLC (Q0666)**

**By:** D Hale

**Title:** Managing Member

**Date:** 8/8/23



**Interconnection Agreement for Small Generator Facility  
Tier 1, Tier 2, Tier 3 or Tier 4 Interconnection  
(Small Generator Facilities with Electric Nameplate Capacities of 10MW or less)**

**Attachment 3**

**Milestones**

Estimated In-Service Date: September 30, 2025

Critical milestones and responsibility as agreed to by the Parties:

	<b>Milestone/Date</b>	<b>Responsible Party</b>
(1)	<u>Execute Agreement and Provide \$10,000 deposit</u> March 15, 2016 - completed	<u>Interconnection Customer</u>
(2)	<u>Retail Service Request Established</u> January 15, 2024	<u>Interconnection Customer</u>
(3)	<u>*Initial Design Information Provided</u> January 15, 2024	<u>Interconnection Customer</u>
(4)	<u>Begin Engineering Design</u> March 4, 2024	<u>Public Utility</u>
(5)	<u>Obtain Property Rights</u> May 6, 2024	<u>Interconnection Customer</u>
(6)	<u>*Final design information provided</u> October 3, 2024	<u>Interconnection Customer</u>
(7)	<u>Property/Permits/RoW procured</u> October 28, 2024	<u>Public Utility</u>
(8)	<u>Complete Engineering Design</u> November 11, 2024	<u>Public Utility</u>
(9)	<u>Begin Construction</u> January 2, 2025	<u>Public Utility</u>
(10)	<u>Provide Policy 138 required Test &amp; Maintenance Plans</u> August 7, 2025	<u>Interconnection Customer</u>
(11)	<u>Complete Construction</u> September 5, 2025	<u>Both</u>

**Interconnection Agreement for Small Generator Facility  
Tier 1, Tier 2, Tier 3 or Tier 4 Interconnection  
(Small Generator Facilities with Electric Nameplate Capacities of 10MW or less)**

- |      |  |                                 |
|------|--|---------------------------------|
| (12) | <u>Commissioning Complete</u><br>September 19, 2025                        | <u>Public Utility</u>           |
| (13) | <u>Backfeed</u><br>September 22, 2025                                      | <u>Interconnection Customer</u> |
| (14) | <u>Initial synchronization and generator testing</u><br>September 24, 2025 | <u>Interconnection Customer</u> |
| (15) | <u>Commercial Operations</u><br>September 30, 2025                         | <u>Both</u>                     |

Interconnection Customer is to request Backfeed, 1<sup>st</sup> Sync, and Commercial Operations in writing (email acceptable) prior to the above dates. Public Utility is to approve Interconnection Customer requests without unreasonable delay. The Interconnection Customer will be required to demonstrate the reactive capability of the Small Generating Facility and the voltage control system prior to Commercial Operations.

\*Interconnection Customer initial design package shall include final generating facility location, inverter/turbine selection, basic protection package, tie line route and collector system locations and data as applicable. Interconnection Customer final design package shall include PE stamped issued for construction (“IFC”) drawings for generating facility, collector substation, tie line as well as an updated PSS/e model and updated WECC approved model, electromagnetic transient (“EMT”) model and a detailed short circuit model of its generation system using the ASPEN OneLine short circuit simulation program as applicable. The WECC model parameters must be adjusted to reflect the plant’s actual anticipated performance. The plant controller must be included in the model. If there is to be coordination between facilities or a master VAR controller, this must be included in the detailed WECC dynamic model, as well as in the PSS/e user-written model.

## Payment Schedule

If Interconnection Customer elects the progress payments option under Article 4.6 of the Interconnection Agreement, there are two potential options for a payment schedule below (please select one). If Interconnection Customer elects progress payment option but an option below is not selected, the Levelized Option will be selected by default. Failure to comply with the selected payment schedule will result in immediate contractual breach, work stoppage, and slip of the milestone schedule above on a day-for-day basis. Interconnection Customer will still be responsible for all costs of the project. Public Utility will conduct initial accounting for the project within thirty (30) days of granting Commercial Operations approval and will determine if a partial refund of project costs is acceptable.

Please select an option:

Funds due no later than Stepped Option



**Interconnection Agreement for Small Generator Facility  
Tier 1, Tier 2, Tier 3 or Tier 4 Interconnection  
(Small Generator Facilities with Electric Nameplate Capacities of 10MW or less)**

March 15, 2016 (or when Interconnection Agreement is executed)	\$10,000 - Paid
July 1, 2018	\$79,500 - Paid
January 2, 2024	\$200,000
July 2, 2024	\$282,500

**Interconnection Agreement for Small Generator Facility  
Tier 1, Tier 2, Tier 3 or Tier 4 Interconnection  
(Small Generator Facilities with Electric Nameplate Capacities of 10MW or less)**

This Interconnection Agreement for Small Generator Facility (“Agreement”) is made and entered into this 17<sup>th</sup> day of March, 2022, by and between Pilot Rock Solar 2, LLC, a limited liability company organized and existing under the laws of the State of Oregon, (“Interconnection Customer”) and PacifiCorp, a Corporation, existing under the laws of the State of Oregon, (“Public Utility”). The Interconnection Customer and Public Utility may be referred to hereinafter singly as a “Party” or collectively as the “Parties.”

**Recitals:**

**Whereas**, the Interconnection Customer is proposing to develop a Small Generator Facility, or to add generating capacity to an existing Small Generator Facility, consistent with the Application completed on July 17, 2017;

**Whereas**, the Interconnection Customer desires to interconnect the Small Generator Facility with Public Utility’s Transmission System and/or Distribution System (“T&D System”) in the State of Oregon; and

**Whereas**, the interconnection of the Small Generator Facility and the Public Utility’s T&D System is subject to the jurisdiction of the Public Utility Commission of Oregon (“Commission”) and governed by OPUC Rule OAR 860, Division 082 (the “Rule”).

**Now, therefore**, in consideration of and subject to the mutual covenants contained herein, the Parties agree as follows:

**Article 1.      Scope and Limitations of Agreement**

**1.1      Scope**

This Agreement establishes the standard terms and conditions under which the Small Generator Facility with a Nameplate Capacity of no more than 10 megawatts (“MW”) will interconnect to, and operate in Parallel with, the Public Utility’s T&D System. The Commission has approved standard terms and conditions governing this class of interconnection. Any additions, deletions or changes to the standard terms and conditions of interconnection approved by the Commission must be mutually agreed by the Parties or, if required by the Rule, any such changes must be approved by the Commission. Terms with initial capitalization, when used in this Agreement, shall have the meanings given in the Rule. This Agreement shall be construed where possible to be consistent with the Rules; to the extent this Agreement conflicts with the Rule, the Rule shall take precedence.

**1.2      No Agreement Regarding Power Purchase, Transmission, or Delivery**

This Agreement does not constitute an agreement to purchase, transmit, or deliver any power or capacity from the interconnected Small Generating Facility nor does it constitute

**Interconnection Agreement for Small Generator Facility  
Tier 1, Tier 2, Tier 3 or Tier 4 Interconnection  
(Small Generator Facilities with Electric Nameplate Capacities of 10MW or less)**

an electric service agreement.

**1.3 Other Agreements**

Nothing in this Agreement is intended to affect any other agreement between the Public Utility and the Interconnection Customer or any other interconnected entity. If the provisions of this Agreement conflict with the provisions of any other Public Utility tariff, the Public Utility tariff shall control.

**1.4 Responsibilities of the Parties**

- 1.4.1 The Parties shall perform all obligations of this Agreement in accordance with all applicable laws.
- 1.4.2 The Interconnection Customer will construct, own, operate, and maintain its Small Generator Facility in accordance with this Agreement, IEEE Standard 1547 (2003 ed), IEEE Standard 1547.1 (2005 ed), the National Electrical Code (2005 ed) and applicable standards required by the Commission.
- 1.4.3 Each Party shall be responsible for the safe installation, maintenance, repair and condition of their respective lines and appurtenances on their respective sides of the Point of Interconnection. Each Party shall provide Interconnection Facilities that adequately protect the other Parties' facilities, personnel, and other persons from damage and injury. The allocation of responsibility for the design, installation, operation, maintenance and ownership of Interconnection Facilities is prescribed in the Rule and this Agreement and the attachments to this Agreement.

**1.5 Parallel Operation and Maintenance Obligations**

Once the Small Generator Facility has been authorized to commence Parallel Operation by execution of this Agreement and satisfaction of Article 2.1 of this Agreement, the Interconnection Customer will abide by all written provisions for operating and maintenance as required by this Agreement and any attachments to this Agreement as well as by the Rule and as detailed by the Public Utility in Form 7, title "Interconnection Equipment As-Built Specifications, Initial Settings and Operating Requirements".

**1.6 Metering & Monitoring**

The Interconnection Customer will be responsible for metering and monitoring as required by OAR 860-082-0070 and as may be detailed in any attachments to this Agreement.

**1.7 Power Quality**

The Interconnection Customer will design its Small Generator Facility to maintain a composite power delivery at continuous rated power output at the Point of Interconnection that meets the requirements set forth in IEEE 1547. The Public Utility may, in some

**Interconnection Agreement for Small Generator Facility  
Tier 1, Tier 2, Tier 3 or Tier 4 Interconnection  
(Small Generator Facilities with Electric Nameplate Capacities of 10MW or less)**

circumstances, also require the Interconnection Customer to follow voltage or VAR schedules used by similarly situated, comparable generators in the control area. Any special operating requirements will be detailed in Form 7 and completed by the Public Utility as required by the Rule. The Public Utility shall not impose additional requirements for voltage or reactive power support outside of what may be required to mitigate impacts caused by interconnection of the Small Generator Facility to the Public Utility's system.

**Article 2.      Inspection, Testing, Authorization, and Right of Access**

**2.1      Equipment Testing and Inspection**

The Interconnection Customer will test and inspect its Small Generator Facility and Interconnection Facilities prior to interconnection in accordance with IEEE 1547 Standards as provided for in the Rule. The Interconnection will not be final and the Small Generator Facility shall not be authorized to operate in parallel with the Public Utility's T&D System until the Witness Test and Certificate of Completion provisions in the Rule have been satisfied. The Interconnection Customer shall pay or reimburse the Public Utility for its costs to participate in the Witness Test. Operation of the Small Generator Facility requires an effective Interconnection Agreement; electricity sales require a Power Purchase Agreement.

To the extent that the Interconnection Customer decides to conduct interim testing of the Small Generator Facility prior to the Witness Test, it may request that the Public Utility observe these tests. If the Public Utility agrees to send qualified personnel to observe any interim testing proposed by the Interconnection Customer, the Interconnection Customer shall pay or reimburse the Public Utility for its cost to participate in the interim testing. If the Interconnection Customer conducts interim testing and such testing is observed by the Public Utility and the results of such interim testing are deemed acceptable by the Public Utility (hereinafter a "Public Utility-approved interim test"), then the Interconnection Customer may request that such Public Utility-approved interim test be deleted from the final Witness Testing. If the Public Utility elects to repeat any Public Utility-approved interim test as part of the final Witness Test, the Public Utility will bare its own expenses associated with participation in the repeated Public Utility-approved interim test.

**2.2      Right of Access:**

As provided in OAR 860-082-0030(5), the Public Utility will have access to the Interconnection Customer's premises for any reasonable purpose in connection with the Interconnection Application or any Interconnection Agreement that is entered in to pursuant to the Rule or if necessary to meet the legal obligation to provide service to its customers. Access will be requested at reasonable hours and upon reasonable notice, or at any time without notice in the event of an emergency or hazardous condition.

**Interconnection Agreement for Small Generator Facility  
Tier 1, Tier 2, Tier 3 or Tier 4 Interconnection  
(Small Generator Facilities with Electric Nameplate Capacities of 10MW or less)**

**Article 3.      Effective Date, Term, Termination, and Disconnection**

**3.1      Effective Date**

The Agreement shall become effective upon execution by the Parties.

**3.2      Term of Agreement**

The Agreement will be effective on the Effective Date and will remain in effect for a period of twenty (20) years or the life of the Power Purchase agreement, whichever is shorter or a period mutually agreed to by the Parties, unless terminated earlier by the default or voluntary termination by the Interconnection Customer or by action of the Commission.

**3.3      Termination**

No termination will become effective until the Parties have complied with all provisions of OAR 860-082-0080 and this Agreement that apply to such termination.

3.3.1    The Interconnection Customer may terminate this Agreement at any time by giving the Public Utility twenty (20) Business Days written notice.

3.3.2    Either Party may terminate this Agreement after default pursuant to Article 5.6 of this Agreement.

3.3.3    The Commission may order termination of this Agreement.

3.3.4    Upon termination of this Agreement, the Small Generator Facility will be disconnected from the Public Utility's T&D System at the Interconnection Customer's expense. The termination of this Agreement will not relieve either Party of its liabilities and obligations, owed or continuing at the time of the termination.

3.3.4    The provisions of this Article 3.3 shall survive termination or expiration of this Agreement.

**3.4      Temporary Disconnection**

The Public Utility or Interconnection Customer may temporarily disconnect the Small Generator Facility from the Public Utility's T&D System for so long as reasonably necessary, as provided in OAR 860-082-0075 of the Rule, in the event one or more of the following conditions or events occurs:

3.4.1    Under emergency conditions, the Public Utility or the Interconnection Customer may immediately suspend interconnection service and temporarily disconnect the Small Generator Facility without advance notice to the other Party. The Public Utility shall notify the Interconnection Customer promptly when it becomes aware



**Interconnection Agreement for Small Generator Facility  
Tier 1, Tier 2, Tier 3 or Tier 4 Interconnection  
(Small Generator Facilities with Electric Nameplate Capacities of 10MW or less)**

of an emergency condition that may reasonably be expected to affect the Small Generator Facility operation. The Interconnection Customer will notify the Public Utility promptly when it becomes aware of an emergency condition that may reasonably be expected to affect the Public Utility's T&D System. To the extent information is known, the notification shall describe the emergency condition, the extent of the damage or deficiency, the expected effect on the operation of both Parties' facilities and operations, its anticipated duration, and the necessary corrective action.

- 3.4.2 For routine Maintenance, Parties will make reasonable efforts to provide five Business Days notice prior to interruption caused by routine maintenance or construction and repair to the Small Generator Facility or Public Utility's T&D system and shall use reasonable efforts to coordinate such interruption.
- 3.4.3 The Public Utility shall use reasonable efforts to provide the Interconnection Customer with prior notice of forced outages of the T&D System. If prior notice is not given, the Public Utility shall, upon request, provide the Interconnection Customer written documentation after the fact explaining the circumstances of the disconnection.
- 3.4.4 For disruption or deterioration of service, where the Public Utility determines that operation of the Small Generator Facility will likely cause disruption or deterioration of service to other customers served from the same electric system, or if operating the Small Generator Facility could cause damage to the Public Utility's T&D System, the Public Utility may disconnect the Small Generator Facility. The Public Utility will provide the Interconnection Customer upon request all supporting documentation used to reach the decision to disconnect. The Public Utility may disconnect the Small Generator Facility if, after receipt of the notice, the Interconnection Customer fails to remedy the adverse operating effect within a reasonable time which shall be at least five Business Days from the date the Interconnection Customer receives the Public Utility's written notice supporting the decision to disconnect, unless emergency conditions exist, in which case the provisions of 3.4.1 of the agreement apply.
- 3.4.5 If the Interconnection Customer makes any change to the Small Generating Facility, the Interconnection Equipment, the Interconnection Facilities, or to any other aspect of the interconnection, other than Minor Equipment Modifications, without prior written authorization of the Public Utility, the Public Utility will have the right to disconnect the Small Generator Facility until such time as the impact of the change has been studied by the Public Utility and any reasonable requirements or additional equipment or facilities required by the Public Utility to address any impacts from the changes have been implemented by the Parties and approved in

**Interconnection Agreement for Small Generator Facility  
Tier 1, Tier 2, Tier 3 or Tier 4 Interconnection  
(Small Generator Facilities with Electric Nameplate Capacities of 10MW or less)**

writing by the Public Utility. The requirement to apply to the Public Utility for study and approve of modifications is governed by OAR 860-082-0005 (b).

**3.5 Restoration of interconnection:**

The Parties shall cooperate with each other to restore the Small Generator Facility, Interconnection Facilities, and Public Utility's T&D System to their normal operating state as soon as reasonably practicable following any disconnection pursuant to Article 3.4.

**Article 4. Cost Responsibility and Billing:**

As provided in OAR 860-082-0035, the Interconnection Customer is responsible for the cost of all facilities, equipment, modifications and upgrades needed to facilitate the interconnection of the Small Generator Facility to the Public Utility's T&D System.

**4.1 Minor T&D System Modifications:**

As provided in the Rule addressing Tier 2 review (OAR 860-082-0050) and in the Rule addressing Tier 3 review (OAR 860-082-0055), it may be necessary for the Parties to construct certain Minor Modifications in order to interconnect under Tier 2 or Tier 3 review. The Public Utility has itemize any required Minor Modifications in the attachments to this Agreement, including a good-faith estimate of the cost of such Minor Modifications and the time required to build and install such Minor Modifications. The Interconnection Customer agrees to pay the costs of such Minor Modifications.

**4.2 Interconnection Facilities:**

The Public Utility has identified under the review procedures of a Tier 2 review or under a Tier 4 Facilities Study, the Interconnection Facilities necessary to safely interconnect the Small Generator Facility with the Public Utility. The Public Utility has itemized the required Interconnection Facilities in the attachments to this Agreement, including a good-faith estimate of the cost of the facilities and the time required to build and install those facilities. The Interconnection Customer is responsible for the cost of the Interconnection Facilities.

**4.3 Interconnection Equipment:**

The Interconnection Customer is responsible for all reasonable expenses, including overheads, associated with owning, operating, maintaining, repairing, and replacing its Interconnection Equipment.

**4.4 System Upgrades:**

The Public Utility will design, procure, construct, install, and own any System Upgrades. The actual cost of the System Upgrades, including overheads, will be directly assigned to the Interconnection Customer. An Interconnection Customer may be entitled to financial compensation from other Public Utility Interconnection Customers who, in the future, benefit from the System Upgrades paid for by the Interconnection Customer. Such compensation will be governed by separate rules promulgated by the Commission or by

**Interconnection Agreement for Small Generator Facility  
Tier 1, Tier 2, Tier 3 or Tier 4 Interconnection  
(Small Generator Facilities with Electric Nameplate Capacities of 10MW or less)**

terms of a tariff filed and approved by the Commission. Such compensation will only be available to the extent provided for in the separate rules or tariff.

**4.5 Adverse System Impact:**

The Public Utility is responsible for identifying the possible Affected Systems and coordinating with those identified Affected Systems, to the extent reasonably practicable, to allow the Affected System owner an opportunity to identify Adverse System Impacts on its Affected System, and to identify what mitigation activities or upgrades may be required on the Public Utility's system or on the Affected System to address impacts on Affected Systems and accommodate a Small Generator Facility. Such coordination with Affected System owners shall include inviting Affected System owners to scoping meetings between the Public Utility and the Interconnection Customer and providing the Affected System owner with study results and other information reasonably required and requested by the Affected System owner to allow the Affected System owner to assess impacts to its system and determine required mitigation, if any, for such impacts. The Parties acknowledge that the Public Utility cannot compel the participation of the Affected System owner and that the Public Utility is not itself responsible for identifying impacts or mitigation associated with an Affected System. The actual cost of any actions taken to address the Adverse System Impacts, including overheads, shall be directly assigned to the Interconnection Customer. The Interconnection Customer may be entitled to financial compensation from other Public Utilities or other Interconnection Customers who, in the future, utilize the upgrades paid for by the Interconnection Customer, to the extent allowed or required by the Commission. Such compensation will only be available to the extent provided for in the separate rules, Commission order or tariff. If the Parties have actual knowledge of an Adverse System Impact on an Affected System, the Interconnection Customer shall not interconnect and operate its Small Generator Facility in parallel with the Public Utility's system, and the Public Utility shall not authorize or allow the continued interconnection or parallel operation of the Small Generator Facility, unless and until such Adverse System Impact has been addressed to the reasonable satisfaction of the Affected System owner.

**4.6 Deposit and Billings:**

The Interconnection Customer agrees to pay to the Public Utility a deposit toward the cost to construct and install any required Interconnection Facilities and/or System Upgrades. The amount of the deposit shall be (select one of the following):

The Parties have not agreed to a schedule of progress payments and the Interconnection Customer shall pay a deposit equal to 100 percent of the estimated cost of the Interconnection Facilities and System Upgrades – the amount of the deposit shall be \$287,000; or

**Interconnection Agreement for Small Generator Facility  
Tier 1, Tier 2, Tier 3 or Tier 4 Interconnection  
(Small Generator Facilities with Electric Nameplate Capacities of 10MW or less)**

The Parties have agreed to progress payments and final payment under the schedule of payments attached to this Agreement; the Interconnection Customer shall pay a deposit equal to the lesser of (a) 25 percent of the estimated cost of the Interconnection Facilities and System Upgrades, or (b) \$10,000 – the amount of the deposit shall be \$10,000.

If the actual costs of Interconnection Facilities and/or System Upgrades are different than the deposit amounts and/or progress and final payments provided for above, then the Interconnection Customer shall pay the Public Utility any balance owing or the Public Utility shall refund any excess deposit or progress payment within 20 days of the date actual costs are determined

**Article 5. Assignment, Liability, Indemnity, Force Majeure, Consequential Damages, and Default**

**5.1 Assignment**

The Interconnection Agreement may be assigned by either Party upon fifteen (15) Business Days prior written notice. Except as provided in Articles 5.1.1 and 5.1.2, said assignment shall only be valid upon the prior written consent of the non-assigning Party, which consent shall not be unreasonably withheld.

5.1.1 Either Party may assign the Agreement without the consent of the other Party to any affiliate (which shall include a merger of the Party with another entity), of the assigning Party with an equal or greater credit rating and with the legal authority and operational ability to satisfy the obligations of the assigning Party under this Agreement;

5.1.2 The Interconnection Customer shall have the right to assign the Agreement, without the consent of the Public Utility, for collateral security purposes to aid in providing financing for the Small Generator Facility. For Small Generator systems that are integrated into a building facility, the sale of the building or property will result in an automatic transfer of this agreement to the new owner who shall be responsible for complying with the terms and conditions of this Agreement.

5.1.3 Any attempted assignment that violates this Article is void and ineffective. Assignment shall not relieve a Party of its obligations, nor shall a Party's obligations be enlarged, in whole or in part, by reason thereof. An assignee is responsible for meeting the same obligations as the assigning Interconnection Customer.

**5.2 Limitation of Liability and Consequential Damages**

A Party is liable for any loss, cost claim, injury, or expense including reasonable attorney's fees related to or arising from any act or omission in its performance of the provisions of

**Interconnection Agreement for Small Generator Facility  
Tier 1, Tier 2, Tier 3 or Tier 4 Interconnection  
(Small Generator Facilities with Electric Nameplate Capacities of 10MW or less)**

this Agreement entered into pursuant to the Rule except as provided for in ORS 757.300(4)(c). Neither Party will seek redress from the other Party in an amount greater than the amount of direct damage actually incurred.

**5.3 Indemnity**

- 5.3.1 Liability under this Article 5.3 is exempt from the general limitations on liability found in Article 5.2.
- 5.3.2 The Parties shall at all times indemnify, defend, and hold the other Party harmless from, any and all damages, losses, claims, including claims and actions relating to injury to or death of any person or damage to property, demand, suits, recoveries, costs and expenses, court costs, attorney fees, and all other obligations by or to third parties, arising out of or resulting from the other Party's action or failure to meet its obligations under this Agreement on behalf of the indemnifying Party, except in cases of gross negligence or intentional wrongdoing by the indemnified Party.
- 5.3.3 If an indemnified person is entitled to indemnification under this Article 5.3 as a result of a claim by a third party, and the indemnifying Party fails, after notice and reasonable opportunity to proceed under this Article 5.3, to assume the defense of such a claim, such indemnified person may at the expense of the indemnifying Party contest, settle or consent to the entry of any judgment with respect to, or pay in full, such claim.
- 5.3.4 If an indemnifying party is obligated to indemnify and hold any indemnified person harmless under this Article 5.3, the amount owing to the indemnified person shall be the amount of such indemnified person's actual loss, net of any insurance or other recovery.
- 5.3.5 Promptly after receipt by an indemnified person of any claim or notice of the commencement of any action or administrative or legal proceeding or investigation as to which the indemnity provided for in this Article 5.3 may apply, the indemnified person shall notify the indemnifying party of such fact. Any failure of or delay in such notification shall not affect a Party's indemnification obligation unless such failure or delay is materially prejudicial to the indemnifying party.
- 5.3.6 The indemnifying Party shall have the right to assume the defense thereof with counsel designated by such indemnifying Party and reasonably satisfactory to the indemnified person. If the defendants in any such action include one or more indemnified persons and the indemnifying Party and if the indemnified person reasonably concludes that there may be legal defenses available to it and/or other indemnified persons which are different from or additional to those available to the

**Interconnection Agreement for Small Generator Facility  
Tier 1, Tier 2, Tier 3 or Tier 4 Interconnection  
(Small Generator Facilities with Electric Nameplate Capacities of 10MW or less)**

indemnifying Party, the indemnified person shall have the right to select separate counsel to assert such legal defenses and to otherwise participate in the defense of such action on its own behalf. In such instances, the indemnifying Party shall only be required to pay the fees and expenses of one additional attorney to represent an indemnified person or indemnified persons having such differing or additional legal defenses.

- 5.3.7 The indemnified person shall be entitled, at its expense, to participate in any such action, suit or proceeding, the defense of which has been assumed by the indemnifying Party. Notwithstanding the foregoing, the indemnifying Party (i) shall not be entitled to assume and control the defense of any such action, suit or proceedings if and to the extent that, in the opinion of the indemnified person and its counsel, such action, suit or proceeding involves the potential imposition of criminal liability on the indemnified person, or there exists a conflict or adversity of interest between the indemnified person and the indemnifying Party, in such event the indemnifying Party shall pay the reasonable expenses of the indemnified person, and (ii) shall not settle or consent to the entry of any judgment in any action, suit or proceeding without the consent of the indemnified person, which shall not be reasonably withheld, conditioned or delayed.

**5.4 Consequential Damages**

Neither Party shall be liable to the other Party, under any provision of this Agreement, for any losses, damages, costs or expenses for any special, indirect, incidental, consequential, or punitive damages, including but not limited to loss of profit or revenue, loss of the use of equipment, cost of capital, cost of temporary equipment or services, whether based in whole or in part in contract, in tort, including negligence, strict liability, or any other theory of liability; provided, however, that damages for which a Party may be liable to the other Party under another agreement will not be considered to be special, indirect, incidental, or consequential damages hereunder.

**5.5 Force Majeure**

- 5.5.1 As used in this Agreement, a Force Majeure Event shall mean “any act of God, labor disturbance, act of the public enemy, war, acts of terrorism, insurrection, riot, fire, storm or flood, explosion, breakage or accident to machinery or equipment through no direct, indirect, or contributory act of a Party, any order, regulation or restriction imposed by governmental, military or lawfully established civilian authorities, or any other cause beyond a Party’s control. A Force Majeure Event does not include an act of negligence or intentional wrongdoing.”
- 5.5.2 If a Force Majeure Event prevents a Party from fulfilling any obligations under this Agreement, the Party affected by the Force Majeure Event (Affected Party) shall

**Interconnection Agreement for Small Generator Facility  
Tier 1, Tier 2, Tier 3 or Tier 4 Interconnection  
(Small Generator Facilities with Electric Nameplate Capacities of 10MW or less)**

promptly notify the other Party of the existence of the Force Majeure Event. The notification must specify in reasonable detail the circumstances of the Force Majeure Event, its expected duration, and the steps that the Affected Party is taking to mitigate the effects of the event on its performance, and if the initial notification was verbal, it should be promptly followed up with a written notification. The Affected Party shall keep the other Party informed on a continuing basis of developments relating to the Force Majeure Event. Until the Force Majeure Event ends the Affected Party will be entitled to suspend or modify its performance of obligations under this Agreement (other than the obligation to make payments) only to the extent that the effect of the Force Majeure Event cannot be reasonably mitigated. The Affected Party will use reasonable efforts to resume its performance as soon as possible. The Parties shall immediately report to the Commission should a Force Majeure Event prevent performance of an action required by the Rule that the Rule does not permit the Parties to mutually waive.

## **5.6 Default**

- 5.6.1 No default shall exist where such failure to discharge an obligation (other than the payment of money) is the result of a Force Majeure Event as defined in this Agreement, or the result of an act or omission of the other Party. Upon a breach, the non-breaching Party shall give written notice of such breach to the breaching Party. Except as provided in Article 5.6.2, the breaching Party shall have sixty (60) Calendar Days from receipt of the breach notice within which to cure such breach; provided however, if such breach is not capable of cure within 60 Calendar Days, the breaching Party shall commence such cure within twenty (20) Calendar Days after notice and continuously and diligently complete such cure within six months from receipt of the breach notice; and, if cured within such time, the breach specified in such notice shall cease to exist.
- 5.6.2 If a breach is not cured as provided for in this Article 5.6, or if a breach is not capable of being cured within the period provided for herein, the non-breaching Party shall have the right to declare a default and terminate this Agreement by written notice at any time until cure occurs, and be relieved of any further obligation hereunder and, whether or not that Party terminates this Agreement, to recover from the breaching Party all amounts due hereunder, plus all other damages and remedies to which it is entitled at law or in equity. Alternatively, the non-breaching Party shall have the right to seek dispute resolution with the Commission in lieu of default. The provisions of this Article 5.6 will survive termination of the Agreement.

## **Article 6. Insurance**

**Interconnection Agreement for Small Generator Facility  
Tier 1, Tier 2, Tier 3 or Tier 4 Interconnection  
(Small Generator Facilities with Electric Nameplate Capacities of 10MW or less)**

- 6.1** Pursuant to the Rule adopted by the Commission, the Public Utility may not require the Interconnection Customer to maintain general liability insurance in relation to the interconnection of a Small Generator Facility with an Electric Nameplate Capacity of 200 KW or less. With regard to the interconnection of a Small Generator Facility with an Electric Nameplate Capacity equal to or less than 10 MW but in excess of 200 KW, the Interconnection Customer shall, at its own expense, maintain in force throughout the period of this Agreement general liability insurance sufficient to protect any person (including the Public Utility) who may be affected by the Interconnection Customer's Small Generation Facility and its operation and such insurance shall be sufficient to satisfy the Interconnection Customer's indemnification responsibilities under Article 5.3 of this Agreement.
- 6.2** Within ten (10) days following execution of this Agreement, and as soon as practicable after the end of each fiscal year or at the renewal of the insurance policy and in any event within ninety (90) days thereafter, the Interconnection Customer shall provide the Public Utility with certification of all insurance required in this Agreement, executed by each insurer or by an authorized representative of each insurer.
- 6.3** All insurance required by this Article 6 shall name the Public Utility, its parent, associated and Affiliate companies and their respective directors, officers, agents, servants and employees ("Other Party Group") as additional insured. All policies shall contain provisions whereby the insurers waive all rights of subrogation against the Other Party Group and provide thirty (30) Calendar Days advance written notice to the Other Party Group prior to anniversary date of cancellation or any material change in coverage or condition. The Interconnection Customer's insurance shall contain provisions that specify that the policies are primary and shall apply to such extent without consideration for other policies separately carried and shall state that each insured is provided coverage as though a separate policy had been issued to each, except the insurer's liability shall not be increased beyond the amount for which the insurer would have been liable had only one insured been covered. The insurance policies, if written on a Claims First Made Basis, shall be maintained in full force and effect for two (2) years after termination of this Agreement, which coverage may be in the form of tail coverage or extended reporting period coverage if agreed by the Parties.
- 6.4** The Parties agree to report to each other in writing as soon as practical all accidents or occurrences resulting in injuries to any person, including death, and any property damage arising out of this Agreement.
- 6.5** The requirements contained herein as to insurance are not intended to and shall not in any manner, limit or qualify the liabilities and obligations assumed by the Parties under this Agreement.



**Interconnection Agreement for Small Generator Facility  
Tier 1, Tier 2, Tier 3 or Tier 4 Interconnection  
(Small Generator Facilities with Electric Nameplate Capacities of 10MW or less)**

**Article 7.      Dispute Resolution**

Parties will adhere to the dispute resolution provisions in OAR 860-082-0080.

**Article 8.      Miscellaneous**

**8.1      Governing Law, Regulatory Authority, and Rules**

The validity, interpretation and enforcement of the Agreement and each of its provisions shall be governed by the laws of the State of Oregon, without regard to its conflicts of law principles. The Agreement is subject to all applicable laws. Each Party expressly reserves the right to seek changes in, appeal, or otherwise contest any laws, orders, or regulations of a governmental authority.

**8.2      Amendment**

The Parties may mutually agree to amend the Agreement by a written instrument duly executed by both Parties in accordance with provisions of the Rule and applicable Commission Orders and provisions of the laws if the State of Oregon.

**8.3      No Third-Party Beneficiaries**

The Agreement is not intended to and does not create rights, remedies, or benefits of any character whatsoever in favor of any persons, corporations, associations, or entities other than the Parties, and the obligations herein assumed are solely for the use and benefit of the Parties, their successors in interest and where permitted, their assigns.

**8.4      Waiver**

8.4.1    The failure of a Party to the Agreement to insist, on any occasion, upon strict performance of any provision of the Agreement will not be considered a waiver of any obligation, right, or duty of, or imposed upon, such Party.

8.4.2    The Parties may agree to mutually waive a section of this Agreement so long as prior Commission approval of the waiver is not required by the Rule.

8.4.3    Any waiver at any time by either Party of its rights with respect to the Agreement shall not be deemed a continuing waiver or a waiver with respect to any other failure to comply with any other obligation, right, duty of the Agreement. Any waiver of the Agreement shall, if requested, be provided in writing.

**8.5      Entire Agreement**

This Agreement, including any supplementary Form attachments that may be necessary, constitutes the entire agreement between the Parties with reference to the subject matter hereof, and supersedes all prior and contemporaneous understandings or agreements, oral or written, between the Parties with respect to the subject matter of the Agreement. There are no other agreements, representations, warranties, or covenants that constitute any part

**Interconnection Agreement for Small Generator Facility  
Tier 1, Tier 2, Tier 3 or Tier 4 Interconnection  
(Small Generator Facilities with Electric Nameplate Capacities of 10MW or less)**

of the consideration for, or any condition to, either Party's compliance with its obligations under this Agreement.

**8.6 Multiple Counterparts**

This Agreement may be executed in two or more counterparts, each of which is deemed an original but all constitute one and the same instrument.

**8.7 No Partnership**

This Agreement will not be interpreted or construed to create an association, joint venture, agency relationship, or partnership between the Parties or to impose any partnership obligation or partnership liability upon either Party. Neither Party shall have any right, power or authority to enter into any agreement or undertaking for, or act on behalf of, or to act as or be an agent or representative of, or to otherwise bind, the other Party.

**8.8 Severability**

If any provision or portion of this Agreement shall for any reason be held or adjudged to be invalid or illegal or unenforceable by any court of competent jurisdiction or other governmental authority; (1) such portion or provision shall be deemed separate and independent; (2) the Parties shall negotiate in good faith to restore insofar as practicable the benefits to each Party that were affected by such ruling; and (3) the remainder of this Agreement shall remain in full force and effect.

**8.9 Subcontractors**

Nothing in this Agreement shall prevent a Party from utilizing the services of any subcontractor, or designating a third party agent as one responsible for a specific obligation or act required in this Agreement (collectively subcontractors), as it deems appropriate to perform its obligations under this Agreement; provided, however, that each Party will require its subcontractors to comply with all applicable terms and conditions of this Agreement in providing such services and each Party will remain primarily liable to the other Party for the performance of such subcontractor.

8.9.1 The creation of any subcontract relationship shall not relieve the hiring Party of any of its obligations under this Agreement. The hiring Party shall be fully responsible to the other Party for the acts or omissions of any subcontractor the hiring Party hires as if no subcontract had been made. Any applicable obligation imposed by this Agreement upon the hiring Party shall be equally binding upon, and will be construed as having application to, any subcontractor of such Party.

8.9.2 The obligations under this Article 8.9 will not be limited in any way by any limitation of subcontractor's insurance.

**8.10 Reservation of Rights**

**Interconnection Agreement for Small Generator Facility  
Tier 1, Tier 2, Tier 3 or Tier 4 Interconnection  
(Small Generator Facilities with Electric Nameplate Capacities of 10MW or less)**

Either Party will have the right to make a unilateral filing with the Commission to modify this Agreement. This reservation of rights provision will include but is not limited to modifications with respect to any rates terms and conditions, charges, classification of service, rule or regulation under tariff rates or any applicable State or Federal law or regulation. Each Party shall have the right to protest any such filing and to participate fully in any proceeding before the Commission in which such modifications may be considered.

**Article 9. Notices and Records**

**9.1 General**

Unless otherwise provided in this Agreement, any written notice, demand, or request required or authorized in connection with this Agreement shall be deemed properly given if delivered in person, delivered by recognized national courier service, or sent by first class mail, postage prepaid, to the person specified below:

**9.2 Records**

The Public Utility will maintain a record of all Interconnection Agreements and related Form attachments for as long as the interconnection is in place as required by OAR 860-082-0065. The Public Utility will provide a copy of these records to the Interconnection Customer within 15 Business Days if a request is made in writing.

**If to the Interconnection Customer:**

Interconnection Customer: Pilot Rock Solar 2, LLC  
Attention: Daniel Hale  
Address: 153 Lowell Ave  
City: Glendora\_\_\_\_\_ State: CA\_\_\_\_\_ Zip: 91741\_\_\_\_\_  
Phone: 310-975-4732 Fax: 323-782-0760 E-mail: daniel@sunthurstenergy.com  
\_\_\_\_\_

**If to Public Utility:**

Public Utility: PacifiCorp Transmission Services  
Attention: Central Cashier Office  
Address: 825 N.E. Multnomah Street, Suite 550  
City: Portland State: OR Zip: 97232  
Phone: (Insert Number Here) Fax: (Insert Number Here)

**9.3 Billing and Payment**

Billings and payments shall be sent to the addresses set out below: (complete if different than article 9.2 above)



**Interconnection Agreement for Small Generator Facility  
Tier 1, Tier 2, Tier 3 or Tier 4 Interconnection  
(Small Generator Facilities with Electric Nameplate Capacities of 10MW or less)**

**If to the Interconnection Customer**

Interconnection Customer: Pilot Rock Solar 2, LLC  
Attention: Daniel Hale  
Address: 153 Lowell Ave  
City: Glendora \_\_\_\_\_ State: CA \_\_\_\_\_ Zip: 91741 \_\_\_\_\_  
Phone: 310-975-4732 Fax: 323-782-0760 E-mail: daniel@sunthurstenergy.com

**If to Public Utility**

Public Utility: PacifiCorp Transmission  
Attention: Central Cashiers Office  
Address: P.O. Box 2757  
City: Portland State: OR Zip: 97208-2757

**9.4 Designated Operating Representative**

The Parties will designate operating representatives to conduct the communications which may be necessary or convenient for the administration of the operations provisions of this Agreement. This person will also serve as the point of contact with respect to operations and maintenance of the Party’s facilities (complete if different than article 9.2 above)

Interconnection Customer: Pilot Rock Solar 2, LLC  
Attention: Daniel Hale  
Address: 153 Lowell Ave  
City: Glendora \_\_\_\_\_ State: CA \_\_\_\_\_ Zip: 91741 \_\_\_\_\_  
Phone: 310-975-4732 Fax: 323-782-0760 E-mail: daniel@sunthurstenergy.com

Phone: \_\_\_\_\_ Fax: \_\_\_\_\_ E-Mail \_\_\_\_\_

**Public Utility’s Operating Representative: PacifiCorp**

Attention: Grid Operations  
Address: 9915 S.E. Ankeny Street  
City: Portland State: OR Zip: 97216  
Phone: (Insert Number Here) Fax: (Insert Number Here)

**9.5 Changes to the Notice Information**



**Interconnection Agreement for Small Generator Facility  
Tier 1, Tier 2, Tier 3 or Tier 4 Interconnection  
(Small Generator Facilities with Electric Nameplate Capacities of 10MW or less)**

Either Party may change this notice information by giving five Business Days written notice prior to the effective date of the change.

**Article 10. Signatures**

IN WITNESS WHEREOF, the Parties have caused this Agreement to be executed by their respective duly authorized representatives.

**For Public Utility:**

Name: **Rick Vail** Digitally signed by Rick Vail  
Date: 2022.03.17 07:38:49 -07'00'  
Rick Vail  
Title: VP, Transmission  
Date: 03/17/2022

**For the Interconnection Customer:**

Name: D Hale  
Title: Manager  
Date: 3/15/2022

**Interconnection Agreement for Small Generator Facility  
Tier 1, Tier 2, Tier 3 or Tier 4 Interconnection  
(Small Generator Facilities with Electric Nameplate Capacities of 10MW or less)**

**Attachment 1**

**Description of Interconnection Facilities  
And Metering Equipment Operated or Maintained by the Public Utility**

**Small Generating Facility:** Consists of forty-nine (49) Sungrow SG60KU-M inverters for a total requested output of 2.99 MW. The inverters are connected to a single 3 MVA (Z=5.75%) 480 V – 12.5 kV transformer. On the high side of the transformer is a 200 kVA grounding transformer (Z=7%). See Attachment 2.

**Interconnection Customer Interconnection Facilities:** Consists of a relay controlled recloser installed for higher priority Interconnection Request Q0666. See Attachment 2.

**Public Utility's Interconnection Facilities:** Consists of two sets of meters, one previously installed for higher priority Interconnection Request Q0666 and one for the Interconnection Customer's Small Generating Facility. Public Utility will also own generation metering (and disconnect switches on both the Small Generating Facilities. See Attachment 2.

**Estimated Cost of Public Utility's Interconnection Facilities:** Estimated cost of Public Utility's Interconnection Facilities directly assigned to Interconnection Customer: \$92,000.

**Estimated Annual Operation and Maintenance Cost of Public Utility's Interconnection Facilities:** \$1,000. Interconnection Customer shall be responsible for Public Utility's actual cost for maintenance of the Public Utility's Interconnection Facilities.

**Point of Interconnection:** The point where the Public Utility's Interconnection Facilities connect to the Public Utility's 12.5 kV distribution circuit 5W406 out of Pilot Rock substation. See Attachment 2.

**Point of Change of Ownership:** The point where the Interconnection Customer's Interconnection Facilities connect to the Public Utility's Interconnection Facilities. See Attachment 2.

**Interconnection Agreement for Small Generator Facility  
Tier 1, Tier 2, Tier 3 or Tier 4 Interconnection  
(Small Generator Facilities with Electric Nameplate Capacities of 10MW or less)**

**Attachment 2**

**One-line Diagram Depicting the Generating Facility, Interconnection Facilities, Metering Equipment, and Upgrades**

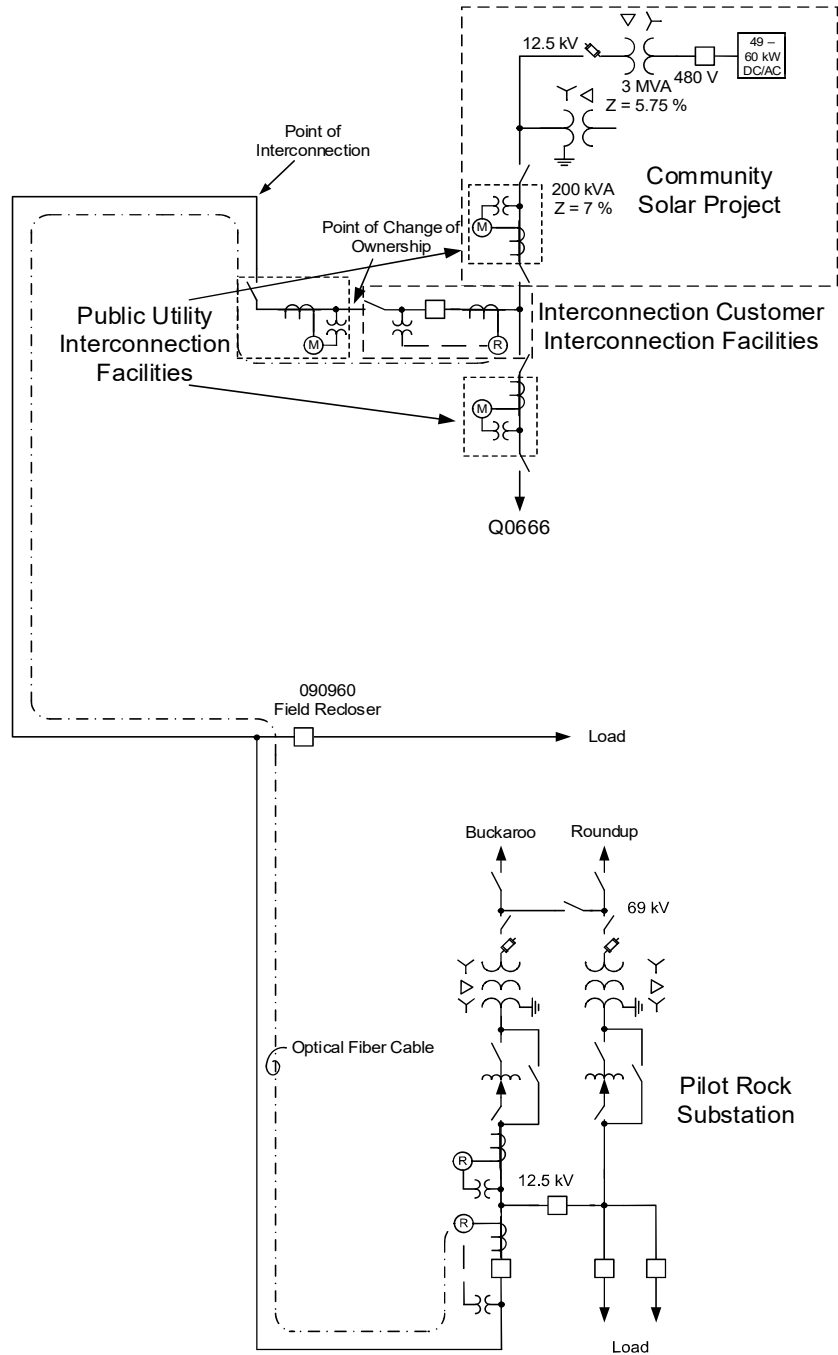



**Interconnection Agreement for Small Generator Facility  
Tier 1, Tier 2, Tier 3 or Tier 4 Interconnection  
(Small Generator Facilities with Electric Nameplate Capacities of 10MW or less)**

**Attachment 3**

**Milestones**

Estimated In-Service Date: December 31, 2022

Critical milestones and responsibility as agreed to by the Parties:

<b>Milestone/Date</b>	<b>Responsible Party</b>
<u>Execute Agreement and provide first prepayment</u> March 15, 2022	<u>Interconnection Customer</u>
<u>Retail Service Request Established</u> <u>March 18, 2022</u>	<u>Interconnection Customer</u>
<u>Shared Facilities Agreement provided</u> March 18, 2022	<u>Interconnection Customer</u>
<u>*Initial design information provided</u> March 18, 2022	<u>Interconnection Customer</u>
<u>**BPA Agreement Executed</u> <u>April 1, 2022</u>	<u>Interconnection Customer</u>
<u>Commence engineering and procurement</u> April 4, 2022	<u>Public Utility</u>
<u>Property/Permits/RoW procured</u> May 6, 2022	<u>Interconnection Customer</u>
<u>*Final design information provided</u> June 10, 2022	<u>Interconnection Customer</u>
<u>Property/Permits/RoW procured</u> July 1, 2022	<u>Public Utility</u>
<u>Engineering design complete</u> September 9, 2022	<u>Public Utility</u>
<u>Commence construction</u>	<u>Public Utility</u>





**Interconnection Agreement for Small Generator Facility  
Tier 1, Tier 2, Tier 3 or Tier 4 Interconnection  
(Small Generator Facilities with Electric Nameplate Capacities of 10MW or less)**

October 17, 2022

Provide maintenance plan  
November 4, 2022

Interconnection Customer

Construction complete  
December 16, 2022

Both Parties

\*\*BPA Requirements Complete  
December 16, 2022

Interconnection Customer

Commissioning complete  
December 28, 2022

Public Utility

Backfeed  
December 29, 2022

Interconnection Customer

Initial synchronization and generator testing  
December 30, 2022

Interconnection Customer

Commercial Operations  
December 31, 2022

Interconnection Customer

Interconnection Customer is to request Backfeed, 1<sup>st</sup> Sync, and Commercial Operations in writing (email acceptable) prior to the above dates. Public Utility is to approve Interconnection Customer requests without unreasonable delay.

\*Interconnection Customer initial design package shall include final generating facility location, inverter/turbine selection, basic protection package, tie line route and collector system locations and data as applicable. Interconnection Customer final design package shall include PE stamped issued for construction (“IFC”) drawings for generating facility, collector substation, tie line as well as electromagnetic transient (“EMT”) model as applicable.

\*\*Any requirements for BPA facilities are out of the control of the Public Utility. If the assumed milestones involving BPA in this Attachment 3 are not met by BPA and the Interconnection Customer, the Public Utility will determine if the Small Generating Facility can operate prior to the completion of BPA requirements and at what level of output and/or curtailment.

**Payment Schedule**

If Interconnection Customer agrees to progress payments option under Article 4.6 of the Interconnection Agreement, there are two potential options for a payment schedule below (please select one). If Interconnection Customer elects progress payment option but an option below is not selected, the Levelized



**Interconnection Agreement for Small Generator Facility  
Tier 1, Tier 2, Tier 3 or Tier 4 Interconnection  
(Small Generator Facilities with Electric Nameplate Capacities of 10MW or less)**

Option will be selected by default. Failure to comply with the selected payment schedule will result in contractual breach, work stoppage, and slip of the milestone schedule above on a day-for-day basis. Interconnection Customer will still be responsible for all costs of the project. Public Utility will conduct initial accounting for the project within thirty (30) days of granting Commercial Operations approval and will determine if a partial refund of project costs is acceptable.

Please select an option:	<input type="checkbox"/>	<input checked="" type="checkbox"/>
<u>Funds due no later than</u> March 15, 2022 (or when Interconnection Agreement is executed)	<u>Levelized Option</u>	<u>Stepped Option</u>
May 6, 2022	\$10,000	\$10,000
August 5, 2022	\$138,500	\$91,000
	\$138,500	\$186,000

**Interconnection Agreement for Small Generator Facility  
Tier 1, Tier 2, Tier 3 or Tier 4 Interconnection  
(Small Generator Facilities with Electric Nameplate Capacities of 10MW or less)**

**Attachment 4**

**Additional Operating Requirements for the Public Utility's  
Transmission System and/or Distribution System and Affected Systems Needed to Support the  
Interconnection Customer's Needs**

The interconnection of the Small Generator Facility is subject to the rules contained within OAR 860 division 82. The interconnection of the Small Generator Facility to the Public Utility's Distribution System shall be subject to, and the Interconnection Customer shall operate the Small Generating Facility in accordance with, the Public Utility's policies governing interconnection of generation facilities to the distribution system entitled "Facility Connection (Interconnection) Requirements for Distribution Systems (34.5 kV and below)" which policy document is available upon request from the Public Utility and is incorporated by this reference as part of the Interconnection Agreement between the Parties. The interconnection of the Small Generator Facility to the Public Utility's Transmission System shall be subject to, and the Interconnection Customer shall operate the Small Generating Facility in accordance with, the Public Utility's policies governing interconnection of generation facilities to the transmission system entitled "Facility Connection (Interconnection) Requirements for Transmission Systems (46 kV and above)" which policy document is available upon request from the Public Utility and is incorporated by this reference as part of the Interconnection Agreement between the Parties. In the event of a conflict between any aspect of this Attachment 4 (including without limitation the Public Utility's policies governing interconnection of generation facilities to the distribution system or the transmission system) and the rules contained in OAR 860, division 82, the rules shall prevail.

Parallel Operation. Interconnection Customer may operate the Generating Facility in parallel with the Public Utility's Transmission System or Distribution System (collectively the "T&D System"), but subject at all times to any operating instructions that the Public Utility's dispatch operators may issue and in accordance with all the provisions of this Interconnection Agreement and Good Utility Practice, and any other conditions imposed by the Public Utility in its sole discretion.

Generating Facility Operation Shall Not Adversely Affect the Public Utility's T&D System.

Interconnection Customer shall operate the Generating Facility in such a manner as not to adversely affect the Public Utility's T&D System or any other element of the Public Utility's electrical system.

Interconnection Customer's Generating Facility shall deliver not more than the Design Capacity of 2.99 MW. Except as otherwise required by this Interconnection Agreement, Interconnection Customer shall operate the Generating Facility in a manner compatible with the Public Utility's applicable voltage level and fluctuating voltage guidelines, entitled Facility Connection (Interconnection) Requirements for Distribution Systems (34.5 kV and below), as it may be amended or superseded from time to time in the Public Utility's reasonable discretion, at the Point of Interconnection during all times that the Generating Facility is connected and operating in parallel with the Public Utility's T&D System. In its sole discretion, the Public Utility may specify rates of change in Interconnection Customer's deliveries to the Public Utility's T&D System during any start-up of the Generating Facility, during reconnection to the

**Interconnection Agreement for Small Generator Facility  
Tier 1, Tier 2, Tier 3 or Tier 4 Interconnection  
(Small Generator Facilities with Electric Nameplate Capacities of 10MW or less)**

Public Utility's T&D System, and during normal operations to assure that such rates of change are compatible with the operation of the Public Utility's voltage regulation equipment.

Maximum Authorized Power Flow. The Generating Facility shall not be operated in a manner that results in the flow of electric power onto the Public Utility's T&D System during any fifteen (15) minute interval at levels in excess of 3 MVA from the Generating Facility. If this provision is violated, the Public Utility may terminate this Interconnection Agreement or lock the Interconnection Customer Disconnect Switch in the open position until such time as: (a) the Public Utility has studied the impact of additional generation on the T&D System (at Interconnection Customer's cost and pursuant to a new study agreement between the Public Utility and Interconnection Customer) and the interconnection has been upgraded (at Interconnection Customer's cost and pursuant to a new or amended Facilities Construction Agreement and a new or amended Interconnection Agreement if deemed necessary by the Public Utility) in any manner necessary to accommodate the additional generation; or (b) the Interconnection Customer has modified the Generating Facility or Interconnection Customer's Interconnection Facilities in such manner as to insure to the Public Utility's satisfaction that the Generating Facility will no longer cause electric power to flow onto the Public Utility's T&D System at a level in excess of 3 MVA.

Islanding. If at any time during the term of this Interconnection Agreement the interconnection of the Generating Facility to the Public Utility's T&D System results in a risk of electrical islanding, or actual occurrences of electrical islanding, which the Public Utility reasonably concludes are incompatible with Good Utility Practice, the Parties shall (as necessary) study the issue and implement a solution that will eliminate or mitigate the risk of electrical islanding to a level deemed acceptable by the Public Utility. All costs associated with addressing any electrical islanding problems as required by this paragraph shall be paid by the Interconnection Customer, including without limitation any study costs, engineering costs, design costs, or costs to procure, install, operate and/or maintain required interconnection facilities or protective devices.

Voltage Regulation. The Interconnection Customer agrees to operate at a  $\pm 95\%$  leading or lagging power factor. Prior to installation, Interconnection Customer shall provide the Public Utility with written notice of the device and/or operational constraints selected to satisfy this requirement and shall obtain the Public Utility's written approval of such device and/or operational constraints, which approval shall not be unreasonably withheld. In the event Interconnection Customer fails to operate the Generating Facility within the voltage regulation constraints of this requirement, the Public Utility may disconnect the Generating Facility.

Modification of Nominal Operating Voltage Level. By providing Interconnection Customer with a one hundred and eighty (180) day notice, the Public Utility may at its sole discretion change the Public Utility's nominal operating voltage level at the Point of Interconnection. In the event of such change in voltage level Interconnection Customer shall, at Interconnection Customer's sole expense, modify Interconnection Customer's Interconnection Facilities as necessary to accommodate the modified nominal operating voltage level. Interconnection Customer has been informed that initial use of a dual voltage

**Interconnection Agreement for Small Generator Facility  
Tier 1, Tier 2, Tier 3 or Tier 4 Interconnection  
(Small Generator Facilities with Electric Nameplate Capacities of 10MW or less)**

Interconnection Customer may ameliorate the cost of accommodating a change in nominal operating voltage level.

Equipment Failure. Interconnection Customer acknowledges that it is responsible for repair or replacement of Interconnection Customer's primary transformer and for any and all other components of the Generating Facility and the Interconnection Customer's Interconnection Facilities. Interconnection Customer is aware that it's inability to timely repair or replace its transformer or any other component of the Generating Facility or Interconnection Customer's Interconnection Facility could result in Interconnection Customer's inability to comply with its responsibilities under this Interconnection Agreement and could lead to disconnection of the Generating Facility from the Public Utility's T&D System and/or termination of this Interconnection Agreement pursuant to the terms of this Interconnection Agreement. Interconnection Customer acknowledges that the risk of this result is born solely by Interconnection Customer and may be substantially ameliorated by Interconnection Customer's elective maintenance of adequate reserve or spare components including but not limited to the Interconnection Customer's primary transformer.

Operation and Maintenance of Facilities Not Owned by the Public Utility. Interconnection Customer shall maintain, test, repair, keep accounts current on, or provide for the proper operation of any and all interconnection facilities, including but not limited to telemetry and communication equipment, not owned by the Public Utility.

Metering and Telemetry Communications Equipment. Notwithstanding any language of OAR 860-082-0070, Public Utility shall not require Interconnection Customer to install a redundant or back-up meter or other telemetry communications equipment. However, Public Utility reserves the right to request that the Oregon Public Utility Commission authorize Public Utility to require Interconnection Customer to be responsible for all reasonable costs associated with redundant metering and communications equipment installed at the Small Generating Facility, upon a determination by Public Utility that such equipment is necessary to maintain compliance with the mandatory reliability standards enforced by the North American Electric Reliability Corporation and the Western Electricity Coordinating Council.

Property Requirements. Interconnection Customer is required to obtain for the benefit of Public Utility at Interconnection Customer's sole cost and expense all real property rights, including but not limited to fee ownership, easements and/or rights of way, as applicable, for Public Utility owned Facilities using Public Utility's standard forms. Public Utility shall not be obligated to accept any such real property right that does not, at Public Utility's sole discretion, confer sufficient rights to access, operate, construct, modify, maintain, place and remove Public Utility owned facilities or is otherwise not conveyed using Public Utility's standard forms. Further, all real property on which Public Utility's Facilities are to be located must be environmentally, physically and operationally acceptable to the Public Utility at its sole discretion. Interconnection Customer is responsible for obtaining all permits required by all relevant jurisdictions for the project, including but not limited to, conditional use permits and construction permits; provided however, Public Utility shall obtain, at Interconnection Customer's cost and schedule risk, the permits necessary to construct Public Utility's Facilities that are to be located on real property currently owned or

**Interconnection Agreement for Small Generator Facility  
Tier 1, Tier 2, Tier 3 or Tier 4 Interconnection  
(Small Generator Facilities with Electric Nameplate Capacities of 10MW or less)**

held in fee or right by Public Utility. Except as expressly waived in writing by an authorized officer of Public Utility, all of the foregoing permits and real property rights (conferring rights on real property that is environmentally, physically and operationally acceptable to Public Utility) shall be acquired as provided herein as a condition to Public Utility's contractual obligation to construct or take possession of facilities to be owned by the Public Utility under this Agreement. Public Utility shall have no liability for any project delays or cost overruns caused by delays in acquiring any of the foregoing permits and/or real property rights, whether such delay results from the failure to obtain such permits or rights or the failure of such permits or rights to meet the requirements set forth herein. Further, any completion dates, if any, set forth herein with regard to Public Utility's obligations shall be equitably extended based on the length and impact of any such delays.

Relay and Control Settings. Interconnection Customer must allow the Public Utility to hold all Level 2 relay passwords for any control and/or protective device within their control at the Point of Interconnection and/or Small Generating Facility which directly impacts the Public Utility's distribution and/or transmission systems. Level 2 passwords are those which allow actual modifications to control and/or relay settings. This will ensure the Public Utility is aware of and approves any changes being made by the Interconnection Customer. Furthermore; this will ensure there are no negative impacts to the Public Utility's distribution system, transmission system, or existing customer base. Should the Interconnection Customer require modification to the settings associated with control/protective devices connected to the distribution and/or transmission system they will contact the Public Utility and provide in writing the justification and/or need for the proposed modifications. This will allow the Public Utility time to analyze and ensure there are no negative impacts to the associated connected systems and customers. Any modifications of control and/or relay settings without review and acknowledgement of acceptance by Public Utility will be considered a breach of interconnect agreement and could lead to permanent disconnection from the Public Utility's system. Public Utility will respond reasonably promptly to Interconnection Customer's requests for changes to the settings on the protective relay in Public Utility's exclusive control.

Qualifying Facility status: The Interconnection Customer covenants that it is, and shall remain throughout the Term of the Agreement, a "Qualifying Facility," as that term is used and defined in 18 C.F.R. Part 292 (2019), and that it shall sell its entire output to Public Utility under terms of a Qualified Facility Power Purchase Agreement. Therefore this Small Generator Facility is considered a Qualifying Facility.

**Interconnection Agreement for Small Generator Facility  
Tier 1, Tier 2, Tier 3 or Tier 4 Interconnection  
(Small Generator Facilities with Electric Nameplate Capacities of 10MW or less)**

**Attachment 5**

**Public Utility' s Description of its Upgrades and Best Estimate of Upgrade Costs**

**Distribution Upgrades:** Install regulators on circuit 5W406.  
Estimated cost is \$180,000.

**System Upgrades:** The following locations will require the System Upgrades described below:

- Regulator setting updates at Pilot Rock substation
- Update databases at control centers
  - Total estimated cost: \$16,000

Contingent Facilities. As identified in the Facilities Study for this project dated June 2, 2020 the following upgrades are required to be in-service prior to this project:

All interconnection facilities and system upgrades required for higher priority Interconnection Request Q0666 are Contingent Facilities for the Interconnection Customer's Interconnection Request including the following:

- Extension of approximately two spans of distribution line.
- Installation of approximately 0.9 miles of fiber optic cable.
- Installation of protective, communications and metering equipment in the Public Utility's Pilot Rock substation.
- Installation of standard Public Utility distribution interconnection package consisting of a metering equipment and switch.
- Installation of an Interconnection Customer owned recloser and relay package.

If the schedule for completion of these upgrades changes or the Interconnection Customer requires an in-service date prior to the completion of these upgrades, the Public Utility reserves the right to restudy this project to determine any additional requirements to assign to this project necessary to facilitate interconnection of this project by the date required.

**Interconnection Agreement for Small Generator Facility  
Tier 1, Tier 2, Tier 3 or Tier 4 Interconnection  
(Small Generator Facilities with Electric Nameplate Capacities of 10MW or less)**

**Attachment 6**

**Scope of Work**

**Shared Q0666-Q1045 Small Generator Facility Requirements**

The following outlines the design, procurement, construction, installation, and ownership of equipment at the Interconnection Customer's Small Generation Facility.

**INTERCONNECTION CUSTOMER TO BE RESPONSIBLE FOR**

- Procure all necessary permits, lands, rights of way and easements required for the construction and continued maintenance of the Q1045 Small Generator Facility and collector substation.
- Design, procure, construct, own and maintain the Interconnection Customer's Small Generator Facility and associated collector substation.
- Execute any necessary agreements (e.g. shared facilities agreement) to allow the Interconnection Customer to utilize the interconnection facilities constructed and owned by the Interconnection Customer with the rights to the Interconnection Request studied under queue position Q0666. Provide this demonstration to the Public Utility prior to the commencement of design activities.
- Design the Small Generating Facility with reactive power capabilities necessary to operate within the full power factor range of 0.95 leading to 0.95 lagging as measured at the Point of Interconnection. The reactive compensation must be designed such that the discreet switching of all reactive devices (if required by the Interconnection Customer) does not cause step voltage changes greater than +/-3% on the Public Utility's system.
- Operate the Small Generating Facility under constant power factor mode with a unity power factor setting unless specifically requested otherwise by the Public Utility. The Small Generating Facility is expressly forbidden from actively participating in voltage regulation of the Public Utilities system without written request or authorization from the Public Utility.
- Operate the Small Generating Facility so minimum power quality requirements in PacifiCorp's Engineering Handbook section 1C are met, the standards are available at <https://www.pacificpower.net/about/power-quality-standards.html>. Requirements specified in the System Impact Study that exceed requirements in the Engineering Handbook section 1C power quality standards shall apply.
- As per NERC standard VAR-001-1, the Public Utility is required to specify voltage or reactive power schedule at the Point of interconnection. Under normal conditions, the Public Utility's system should not supply reactive power to the Small Generating Facility.



**Interconnection Agreement for Small Generator Facility**  
**Tier 1, Tier 2, Tier 3 or Tier 4 Interconnection**  
**(Small Generator Facilities with Electric Nameplate Capacities of 10MW or less)**

- Install a transformer that will hold the phase to neutral voltages within limits when the Small Generator Facility is isolated with the Public Utility's local system until the generation disconnects such as a wye-delta grounding transformer. Please note that the transformer thus far proposed by the Interconnection Customer is not acceptable to the Public Utility.
- Input the updated settings provided by the Public Utility into the Q0666 recloser relay.
- Provide the Public Utility the necessary easement to allow the Public Utility to install an enclosure for its equipment.
- Provide permanent AC power to the Transmission Provider's enclosure.
- Design, procure and install conduit and Public Utility provided control cabling and hard wire all Q0666 and Q1045 source devices to the Public Utility's remote terminal unit ("RTU"). Provide sufficient control cable for the Public Utility to terminate inside the Public Utility enclosure.
- Interconnection Customer shall provide the following data points:
  - Analogs:
    - Net Generation real power MW
    - Net Generator reactive power MVAR
    - Energy Register KWH
    - Q0666 real power MW
    - Q0666 reactive power MVAR
    - Q0666 Energy Register KWH
    - Q1045 real power MW
    - Q1045 reactive power MVAR
    - Q1045 Energy Register KWH
    - A phase 12.5 kV voltage
    - B phase 12.5 kV voltage
    - C phase 12.5 kV voltage
    - Global Horizontal Irradiance (GHI)
    - Average Plant Atmospheric Pressure (Bar)
    - Average Plant Temperature (Celsius)
  - Status:
    - 12 kV Circuit Recloser
    - Max Gen MW
    - Max Gen MW FB
- Arrange for and provide permanent retail service for power that will flow from the Public Utility's system when the Q0666 and Q1045 Small Generator Facilities are not generating. This arrangement must be in place prior to approval for backfeed.
- Provide any construction or backup retail service necessary for the Project.

**Interconnection Agreement for Small Generator Facility  
Tier 1, Tier 2, Tier 3 or Tier 4 Interconnection  
(Small Generator Facilities with Electric Nameplate Capacities of 10MW or less)**

- Provide the Public Utility a Professional Engineer (“PE”) approved maintenance plan for all Interconnection Customer interconnection facilities prior to commencement of generation activities.

**PUBLIC UTILITY TO BE RESPONSIBLE FOR**

- Develop and provide updated settings for the Q0666 recloser relay to account for the addition of the Q1045 Small Generator Facility. Observe and provide acceptance of the update.
- Procure and install, at the Public Utility’s expense, a weather proof enclosure on the site prepared by the Interconnection Customer.
- Provide the Interconnection Customer control cable in sufficient quantity to allow the Interconnection Customer to tie its source devices to the Public Utility’s enclosure communications equipment.
- Terminate the control cable running from the Interconnection Customer source devices in the enclosure.
- Design, procure and install within a NEMA enclosure mounted on a pole, two sets of revenue metering equipment to separate the Q0666 and Q1045 Small Generator Facilities including a metering panel, instrument transformers, primary and secondary revenue quality meters, test switches, junction boxes and secondary metering wire.
- Establish an Ethernet connection for retail sales and generation accounting via the MV-90 translation system. If Ethernet is unavailable, install a cell phone package.

**Other Requirements**

The following outlines the design, procurement, construction, installation, and ownership of equipment beyond the Point of Interconnection.

**INTERCONNECTION CUSTOMER TO BE RESPONSIBLE FOR**

- Bonneville Power Administration (“BPA”)
  - Execute any necessary agreements with BPA to allow BPA to modify relay settings at BPA’s Roundup substation required in order to mitigate system outage condition risks to the Public Utility’s system.

**PUBLIC UTILITY TO BE RESPONSIBLE FOR**

- Distribution Circuit
  - Procure and install one three phase bank of 219 amp 7.2 kV voltage regulators on the McKay branch.

**Interconnection Agreement for Small Generator Facility  
Tier 1, Tier 2, Tier 3 or Tier 4 Interconnection  
(Small Generator Facilities with Electric Nameplate Capacities of 10MW or less)**

- Procure and install one three phase bank of 100 amp 7.2 kV voltage regulators on the circuit branch west of the interconnection tap.
- Pilot Rock Substation
  - Modify the settings of the R-816 substation voltage regulator.

## AGREEMENT TO AMEND INTERCONNECTION AGREEMENT FOR SMALL GENERATOR FACILITY

This **Agreement To Amend Interconnection Agreement for Small Generator Facility** (“Agreement”) is made and entered into this 16th day of August, 2022, by and between PacifiCorp, an Oregon corporation (the “Public Utility”) and Pilot Rock Solar 2, LLC, an Oregon limited liability company (the “Interconnection Customer”). Public Utility and Interconnection Customer may be referred to as a “Party” or collectively as the “Parties.”

### RECITALS

**WHEREAS**, Public Utility and Interconnection Customer have entered into a Generator Interconnection Agreement (“Interconnection Agreement”), dated March 17, 2022;

**WHEREAS**, Public Utility and Interconnection Customer have mutually agreed to amend one or more attachments to the Interconnection Agreement; and

**WHEREAS**, Article 8.2 of the Interconnection Agreement states that the Parties may mutually agree to amend this Interconnection Agreement by a written instrument duly executed by both parties;

**NOW, THEREFORE**, in consideration of and subject to the mutual covenants contained herein, it is agreed:

- 1.0 The Parties acknowledge and mutually agree that the following attached attachments will substitute in their entirety the same attachments in the Interconnection Agreement:
  - Attachment 3
  - Attachment 6
- 2.0 Service under the Interconnection Agreement with the amended attachments will commence only upon execution by both Parties.
- 3.0 The Interconnection Agreement, with the attached substitute attachments shall constitute the entire agreement between the Parties.
- 4.0 All other provisions of the Interconnection Agreement will continue to apply.

**IN WITNESS WHEREOF**, the Parties have executed this Agreement in duplicate originals, each of which shall constitute and be an original effective Agreement between the Parties.

**PacifiCorp**

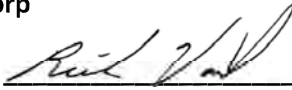
**By:** 

**Title:** VP, Transmission

**Date:** 08/16/2022

**Pilot Rock Solar 2, LLC**

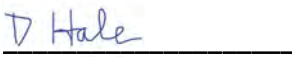
**By:** 

**Title:** Manager

**Date:** 8/12/2022



**Interconnection Agreement for Small Generator Facility  
Tier 1, Tier 2, Tier 3 or Tier 4 Interconnection  
(Small Generator Facilities with Electric Nameplate Capacities of 10MW or less)**

**Attachment 3**

**Milestones**

Estimated In-Service Date: May 25, 2023

Critical milestones and responsibility as agreed to by the Parties:

<b>Milestone/Date</b>	<b>Responsible Party</b>
<u>Execute Agreement and provide first prepayment</u> March 15, 2022	<u>Interconnection Customer</u>
<u>Retail Service Request Established</u> <u>March 18, 2022</u>	<u>Interconnection Customer</u>
<u>Shared Facilities Agreement provided</u> March 18, 2022	<u>Interconnection Customer</u>
<u>*Initial design information provided</u> March 18, 2022	<u>Interconnection Customer</u>
<u>**BPA Agreement Executed</u> <u>April 1, 2022</u>	<u>Interconnection Customer</u>
<u>Commence engineering and procurement</u> April 4, 2022	<u>Public Utility</u>
<u>Property/Permits/RoW procured</u> September 23, 2022	<u>Interconnection Customer</u>
<u>*Final design information provided</u> October 3, 2022	<u>Interconnection Customer</u>
<u>Property/Permits/RoW procured</u> October 28, 2022	<u>Public Utility</u>
<u>Engineering design complete</u> November 11, 2022	<u>Public Utility</u>
<u>Commence construction</u>	<u>Public Utility</u>



**Interconnection Agreement for Small Generator Facility  
Tier 1, Tier 2, Tier 3 or Tier 4 Interconnection  
(Small Generator Facilities with Electric Nameplate Capacities of 10MW or less)**

February 6, 2023

Provide maintenance plan  
April 7, 2023

Interconnection Customer

Construction complete  
May 5, 2023

Both Parties

\*\*BPA Requirements Complete  
May 5, 2023

Interconnection Customer

Commissioning complete  
May 19, 2023

Public Utility

Backfeed  
May 22, 2023

Interconnection Customer

Initial synchronization and generator testing  
May 24, 2023

Interconnection Customer

Commercial Operations  
May 25, 2023

Interconnection Customer

Interconnection Customer is to request Backfeed, 1<sup>st</sup> Sync, and Commercial Operations in writing (email acceptable) prior to the above dates. Public Utility is to approve Interconnection Customer requests without unreasonable delay.

\*Interconnection Customer initial design package shall include final generating facility location, inverter/turbine selection, basic protection package, tie line route and collector system locations and data as applicable. Interconnection Customer final design package shall include PE stamped issued for construction (“IFC”) drawings for generating facility, collector substation, tie line as well as electromagnetic transient (“EMT”) model as applicable.

\*\*Any requirements for BPA facilities are out of the control of the Public Utility. If the assumed milestones involving BPA in this Attachment 3 are not met by BPA and the Interconnection Customer, the Public Utility will determine if the Small Generating Facility can operate prior to the completion of BPA requirements and at what level of output and/or curtailment.

**Payment Schedule**

If Interconnection Customer agrees to progress payments option under Article 4.6 of the Interconnection Agreement, there are two potential options for a payment schedule below (please select one). If Interconnection Customer elects progress payment option but an option below is not selected, the Levelized



**Interconnection Agreement for Small Generator Facility  
Tier 1, Tier 2, Tier 3 or Tier 4 Interconnection  
(Small Generator Facilities with Electric Nameplate Capacities of 10MW or less)**

Option will be selected by default. Failure to comply with the selected payment schedule will result in contractual breach, work stoppage, and slip of the milestone schedule above on a day-for-day basis. Interconnection Customer will still be responsible for all costs of the project. Public Utility will conduct initial accounting for the project within thirty (30) days of granting Commercial Operations approval and will determine if a partial refund of project costs is acceptable.

Please select an option:	<input type="checkbox"/>	<input type="checkbox"/>
<u>Funds due no later than</u> March 15, 2022 (or when Interconnection Agreement is executed)	<u>Levelized Option</u>	<u>Stepped Option</u>
December 1, 2022	\$10,000	\$10,000
March 1, 2023	\$138,500	\$91,000
	\$138,500	\$186,000



**Interconnection Agreement for Small Generator Facility  
Tier 1, Tier 2, Tier 3 or Tier 4 Interconnection  
(Small Generator Facilities with Electric Nameplate Capacities of 10MW or less)**

**Attachment 5**

**Public Utility' s Description of its Upgrades and Best Estimate of Upgrade Costs**

**Distribution Upgrades:** Install regulators on circuit 5W406.  
Estimated cost is \$180,000.

**System Upgrades:** The following locations will require the System Upgrades described below:

- Regulator setting updates at Pilot Rock substation
- Update databases at control centers
  - Total estimated cost: \$16,000

Contingent Facilities. As identified in the Facilities Study for this project dated June 2, 2020 the following upgrades are required to be in-service prior to this project:

All interconnection facilities and system upgrades required for higher priority Interconnection Request Q0666 are Contingent Facilities for the Interconnection Customer's Interconnection Request including the following:

- Extension of approximately two spans of distribution line.
- Installation of approximately 0.9 miles of fiber optic cable.
- Installation of protective, communications and metering equipment in the Public Utility's Pilot Rock substation.
- Installation of standard Public Utility distribution interconnection package consisting of a metering equipment and switch.
- Installation of an Interconnection Customer owned recloser and relay package.

If the schedule for completion of these upgrades changes or the Interconnection Customer requires an in-service date prior to the completion of these upgrades, the Public Utility reserves the right to restudy this project to determine any additional requirements to assign to this project necessary to facilitate interconnection of this project by the date required.

**Interconnection Agreement for Small Generator Facility  
Tier 1, Tier 2, Tier 3 or Tier 4 Interconnection  
(Small Generator Facilities with Electric Nameplate Capacities of 10MW or less)**

**Attachment 6**

**Scope of Work**

**Shared Q0666-Q1045 Small Generator Facility Requirements**

The following outlines the design, procurement, construction, installation, and ownership of equipment at the Interconnection Customer's Small Generation Facility.

**INTERCONNECTION CUSTOMER TO BE RESPONSIBLE FOR**

- Procure all necessary permits, lands, rights of way and easements required for the construction and continued maintenance of the Q1045 Small Generator Facility and collector substation.
- Design, procure, construct, own and maintain the Interconnection Customer's Small Generator Facility and associated collector substation.
- Execute any necessary agreements (e.g. shared facilities agreement) to allow the Interconnection Customer to utilize the interconnection facilities constructed and owned by the Interconnection Customer with the rights to the Interconnection Request studied under queue position Q0666. Provide this demonstration to the Public Utility prior to the commencement of design activities.
- Design the Small Generating Facility with reactive power capabilities necessary to operate within the full power factor range of 0.95 leading to 0.95 lagging as measured at the Point of Interconnection. The reactive compensation must be designed such that the discreet switching of all reactive devices (if required by the Interconnection Customer) does not cause step voltage changes greater than +/-3% on the Public Utility's system.
- Operate the Small Generating Facility under constant power factor mode with a unity power factor setting unless specifically requested otherwise by the Public Utility. The Small Generating Facility is expressly forbidden from actively participating in voltage regulation of the Public Utilities system without written request or authorization from the Public Utility.
- Operate the Small Generating Facility so minimum power quality requirements in PacifiCorp's Engineering Handbook section 1C are met, the standards are available at <https://www.pacificpower.net/about/power-quality-standards.html>. Requirements specified in the System Impact Study that exceed requirements in the Engineering Handbook section 1C power quality standards shall apply.
- As per NERC standard VAR-001-1, the Public Utility is required to specify voltage or reactive power schedule at the Point of interconnection. Under normal conditions, the Public Utility's system should not supply reactive power to the Small Generating Facility.

**Interconnection Agreement for Small Generator Facility  
Tier 1, Tier 2, Tier 3 or Tier 4 Interconnection  
(Small Generator Facilities with Electric Nameplate Capacities of 10MW or less)**

- Install a transformer that will hold the phase to neutral voltages within limits when the Small Generator Facility is isolated with the Public Utility's local system until the generation disconnects such as a wye-delta grounding transformer. Please note that the transformer thus far proposed by the Interconnection Customer is not acceptable to the Public Utility.
- Input the updated settings provided by the Public Utility into the Q0666 recloser relay.
- Provide the Public Utility the necessary easement to allow the Public Utility to install an enclosure for its equipment.
- Provide permanent AC power to the Public Utility's enclosure.
- Arrange for and provide permanent retail service for power that will flow from the Public Utility's system when the Q0666 and Q1045 Small Generator Facilities are not generating. This arrangement must be in place prior to approval for backfeed.
- Provide any construction or backup retail service necessary for the Project.
- Provide the Public Utility a Professional Engineer ("PE") approved maintenance plan for all Interconnection Customer interconnection facilities prior to commencement of generation activities.

**PUBLIC UTILITY TO BE RESPONSIBLE FOR**

- Develop and provide updated settings for the Q0666 recloser relay to account for the addition of the Q1045 Small Generator Facility. Observe and provide acceptance of the update.
- Design, procure and install within a NEMA enclosure mounted on a pole, two sets of revenue metering equipment to separate the Q0666 and Q1045 Small Generator Facilities including a metering panel, instrument transformers, primary and secondary revenue quality meters, test switches, junction boxes and secondary metering wire.
- Establish an Ethernet connection for retail sales and generation accounting via the MV-90 translation system. If Ethernet is unavailable, install a cell phone package.
- Procure and install, at the Public Utility's expense, communications equipment required to facilitate the acquisition of standard SCADA points to be communicated to the Public Utility's System Operations Centers:

**Other Requirements**

The following outlines the design, procurement, construction, installation, and ownership of equipment beyond the Point of Interconnection.

**INTERCONNECTION CUSTOMER TO BE RESPONSIBLE FOR**

**Interconnection Agreement for Small Generator Facility  
Tier 1, Tier 2, Tier 3 or Tier 4 Interconnection  
(Small Generator Facilities with Electric Nameplate Capacities of 10MW or less)**

- Bonneville Power Administration (“BPA”)
  - Execute any necessary agreements with BPA to allow BPA to modify relay settings at BPA’s Roundup substation required in order to mitigate system outage condition risks to the Public Utility’s system.

**PUBLIC UTILITY TO BE RESPONSIBLE FOR**

- Distribution Circuit
  - Procure and install one three phase bank of 219 amp 7.2 kV voltage regulators on the McKay branch.
  - Procure and install one three phase bank of 100 amp 7.2 kV voltage regulators on the circuit branch west of the interconnection tap.
- Pilot Rock Substation
  - Modify the settings of the R-816 substation voltage regulator.

## AGREEMENT TO AMEND INTERCONNECTION AGREEMENT FOR SMALL GENERATOR FACILITY

This **Agreement To Amend Interconnection Agreement for Small Generator Facility** (“Agreement”) is made and entered into this 22nd day of May, 2023, by and between PacifiCorp, an Oregon corporation (the “Public Utility”) and Pilot Rock Solar 2, LLC (Q1045), an Oregon limited liability company (the “Interconnection Customer”). Public Utility and Interconnection Customer may be referred to as a “Party” or collectively as the “Parties.”

### RECITALS

**WHEREAS**, Public Utility and Interconnection Customer have entered into a Generator Interconnection Agreement (“Interconnection Agreement”), dated March 17, 2022 and amended on August 16, 2022;

**WHEREAS**, Public Utility and Interconnection Customer have mutually agreed to amend one or more attachments to the Interconnection Agreement; and

**WHEREAS**, Article 8.2 of the Interconnection Agreement states that the Parties may mutually agree to amend this Interconnection Agreement by a written instrument duly executed by both parties;

**NOW, THEREFORE**, in consideration of and subject to the mutual covenants contained herein, it is agreed:

- 1.0 The Parties acknowledge and mutually agree that the following attached attachment will substitute in its entirety the same attachment in the Interconnection Agreement:
  - Attachment 3
- 2.0 Service under the Interconnection Agreement with the amended attachment will commence only upon execution by both Parties.
- 3.0 The Interconnection Agreement, with the attached substitute attachment shall constitute the entire agreement between the Parties.
- 4.0 All other provisions of the Interconnection Agreement will continue to apply.

**IN WITNESS WHEREOF**, the Parties have executed this Agreement in duplicate originals, each of which shall constitute and be an original effective Agreement between the Parties.

**PacifiCorp**  
**By:** Kristopher J Bremer  
Kristopher J  
Bremer  
2023.05.22  
19:16:57 -07'00'  
**Title:** Dir., Transmission Svcs  
**Date:** 05/22/2023

**Pilot Rock Solar 2, LLC (Q1045)**  
**By:** D Hale  
**Title:** Managing Member  
**Date:** 5/8/23



**Interconnection Agreement for Small Generator Facility  
Tier 1, Tier 2, Tier 3 or Tier 4 Interconnection  
(Small Generator Facilities with Electric Nameplate Capacities of 10MW or less)**

**Attachment 3**

**Milestones**

Estimated In-Service Date: September 30, 2025

Critical milestones and responsibility as agreed to by the Parties:

<b>Milestone/Date</b>	<b>Responsible Party</b>
<u>Execute Agreement and provide first prepayment</u> March 15, 2022 - completed	<u>Interconnection Customer</u>
<u>Retail Service Request Established</u> January 15, 2024	<u>Interconnection Customer</u>
<u>Shared Facilities Agreement provided</u> January 15, 2024	<u>Interconnection Customer</u>
<u>*Initial design information provided</u> January 15, 2024	<u>Interconnection Customer</u>
<u>**BPA Agreement Executed</u> February 1, 2024	<u>Interconnection Customer</u>
<u>Commence engineering and procurement</u> March 4, 2024	<u>Public Utility</u>
<u>Property/Permits/RoW procured</u> May 6, 2024	<u>Interconnection Customer</u>
<u>*Final design information provided</u> October 3, 2024	<u>Interconnection Customer</u>
<u>Property/Permits/RoW procured</u> October 28, 2024	<u>Public Utility</u>
<u>Engineering design complete</u> November 11, 2024	<u>Public Utility</u>
<u>Commence construction</u>	<u>Public Utility</u>



**Interconnection Agreement for Small Generator Facility  
Tier 1, Tier 2, Tier 3 or Tier 4 Interconnection  
(Small Generator Facilities with Electric Nameplate Capacities of 10MW or less)**

January 2, 2025

Provide maintenance plan  
August 7, 2025

Interconnection Customer

Construction complete  
September 5, 2025

Both Parties

\*\*BPA Requirements Complete  
September 5, 2025

Interconnection Customer

Commissioning complete  
September 19, 2025

Public Utility

Backfeed  
September 22, 2025

Interconnection Customer

Initial synchronization and generator testing  
September 24, 2025

Interconnection Customer

Commercial Operations  
September 30, 2025

Interconnection Customer

Interconnection Customer is to request Backfeed, 1<sup>st</sup> Sync, and Commercial Operations in writing (email acceptable) prior to the above dates. Public Utility is to approve Interconnection Customer requests without unreasonable delay.

\*Interconnection Customer initial design package shall include final generating facility location, inverter/turbine selection, basic protection package, tie line route and collector system locations and data as applicable. Interconnection Customer final design package shall include PE stamped issued for construction (“IFC”) drawings for generating facility, collector substation, tie line as well as electromagnetic transient (“EMT”) model as applicable.

\*\*Any requirements for BPA facilities are out of the control of the Public Utility. If the assumed milestones involving BPA in this Attachment 3 are not met by BPA and the Interconnection Customer, the Public Utility will determine if the Small Generating Facility can operate prior to the completion of BPA requirements and at what level of output and/or curtailment.

**Payment Schedule**

If Interconnection Customer agrees to progress payments option under Article 4.6 of the Interconnection Agreement, there are two potential options for a payment schedule below (please select one). If Interconnection Customer elects progress payment option but an option below is not selected, the Levelized





**Interconnection Agreement for Small Generator Facility  
Tier 1, Tier 2, Tier 3 or Tier 4 Interconnection  
(Small Generator Facilities with Electric Nameplate Capacities of 10MW or less)**

Option will be selected by default. Failure to comply with the selected payment schedule will result in contractual breach, work stoppage, and slip of the milestone schedule above on a day-for-day basis. Interconnection Customer will still be responsible for all costs of the project. Public Utility will conduct initial accounting for the project within thirty (30) days of granting Commercial Operations approval and will determine if a partial refund of project costs is acceptable.

Please select an option:	<input type="checkbox"/>	<input type="checkbox"/>
<u>Funds due no later than</u> March 15, 2022 (or when Interconnection Agreement is executed)	<u>Levelized Option</u>	<u>Stepped Option</u>
January 2, 2024	\$10,000 - paid	\$10,000 - paid
July 2, 2024	\$138,500	\$91,000
	\$138,500	\$186,000



## Interconnection Agreement for a Community Solar Project

This Interconnection Agreement for a Community Solar Project (“Agreement”) is made and entered into this 28th day of December, 2021, by and between Sunthurst Energy LLC (OCS024), a limited liability company organized and existing under the laws of the State of Oregon, (“Interconnection Customer” or “Applicant”) and PacifiCorp, a corporation, existing under the laws of the State of Oregon, (“Public Utility”). The Interconnection Customer and Public Utility may be referred to hereinafter singly as a “Party” or collectively as the “Parties.”

### **Recitals:**

**Whereas**, the Interconnection Customer is proposing to develop a Community Solar Project, consistent with the Application completed on April 29, 2020;

**Whereas**, the Interconnection Customer desires to interconnect the Community Solar Project with Public Utility’s Distribution System (“Distribution System”) in the State of Oregon; and

**Whereas**, the interconnection of the Community Solar Project and the Public Utility’s Distribution System is subject to the jurisdiction of the Public Utility Commission of Oregon (“Commission”) and are governed by OPUC Rule OAR 860, Division 088 (the “Rule”) and Public Utility’s Community Solar Interconnection Procedures (“CSP Interconnection Procedures”)

**Now, therefore**, in consideration of and subject to the mutual covenants contained herein, the Parties agree as follows:

### **Article 1.      Scope and Limitations of Agreement**

#### **1.1      Scope**

This Agreement establishes the standard terms and conditions under which the Community Solar Project with a Nameplate Capacity of no more than 3 megawatts (“MW”) will interconnect to, and operate in Parallel with, the Public Utility’s Distribution System. The Commission has approved standard terms and conditions governing this class of interconnection. Any additions, deletions or changes to the standard terms and conditions of interconnection as mutually agreed to by the Parties must be approved by the Commission. Terms with initial capitalization, when used in this Agreement, shall have the meanings given in the CSP Interconnection Procedures. This Agreement shall be construed where possible to be consistent with the Rule and the CSP Interconnection Procedures; to the extent this Agreement conflicts with the Rule or the CSP Interconnection Procedures, the Rule or CSP Interconnection Procedures shall take precedence.

#### **1.2      Definitions**

Unless defined in this Agreement, when used in this Agreement, with initial capitalization, the terms specified shall have the meanings given in CSP Interconnection Procedures.

#### **1.3      No Agreement Regarding Power Purchase, Transmission, or Delivery**

This Agreement does not constitute an agreement to purchase, transmit, or deliver any power



## **Interconnection Agreement for a Community Solar Project**

or capacity from the interconnected Community Solar Project nor does it constitute an electric service agreement.

### **1.4 Other Agreements**

Nothing in this Agreement is intended to affect any other agreement between the Public Utility and the Interconnection Customer or any other interconnected entity. If the provisions of this Agreement conflict with the provisions of any other Public Utility tariff or the CSP Interconnection Procedures, the Public Utility tariff or CSP Interconnection Procedures, as applicable, shall control.

### **1.5 Responsibilities of the Parties**

- 1.5.1 The Parties shall perform all obligations of this Agreement in accordance with all applicable laws.
- 1.5.2 The Interconnection Customer will construct, own, operate, and maintain its Community Solar Project in accordance with this Agreement, IEEE Standard 1547 (2003 ed), IEEE Standard 1547.1 (2005 ed), the National Electrical Code (2005 ed) and applicable standards required by the Commission and this Agreement.
- 1.5.3 Each Party shall be responsible for the safe installation, maintenance, repair and condition of their respective lines and appurtenances on their respective sides of the Point of Interconnection. Each Party shall provide Interconnection Facilities that adequately protect the other Parties' facilities, personnel, and other persons from damage and injury. The allocation of responsibility for the design, installation, operation, maintenance and ownership of Interconnection Facilities is prescribed in the Rule and this Agreement and the attachments to this Agreement.

### **1.6 Parallel Operation and Maintenance Obligations**

Once the Community Solar Project has been authorized to commence Parallel Operation by execution of this Agreement and satisfaction of Article 2.1 of this Agreement, the Interconnection Customer will abide by all written provisions for operating and maintenance as required by this Agreement and any attachments to this Agreement as well as by the Rule and as detailed by the Public Utility in a certification form, "Operations Form", title "Interconnection Equipment As-Built Specifications, Initial Settings and Operating Requirements."

### **1.7 Metering & Monitoring**

The Interconnection Customer will be responsible for metering and monitoring as required by the CSP Interconnection Procedures and as may be detailed in any attachments to this Agreement.

### **1.8 Power Quality**

The Interconnection Customer will design its Community Solar Project to maintain a composite power delivery at continuous rated power output at the Point of Interconnection

## **Interconnection Agreement for a Community Solar Project**

that meets the requirements set forth in IEEE 1547. The Public Utility may, in some circumstances, also require the Interconnection Customer to follow voltage or VAR schedules used by similarly situated, comparable generators in the control area. Any special operating requirements will be detailed in Operations Form and completed by the Public Utility as required by the Rule. The Public Utility shall not impose additional requirements for voltage or reactive power support outside of what may be required to mitigate impacts caused by interconnection of the Community Solar Project to the Public Utility's system.

### **Article 2. Inspection, Testing, Authorization, and Right of Access**

#### **2.1 Equipment Testing and Inspection**

The Interconnection Customer will test and inspect its Community Solar Project and Interconnection Facilities prior to interconnection in accordance with IEEE 1547 Standards as provided for in the Rule. The Interconnection will not be final and the Community Solar Project shall not be authorized to operate in parallel with the Public Utility's Distribution System until the Witness Test and Certificate of Completion provisions in the Rule have been satisfied. The Interconnection Customer shall pay or reimburse the Public Utility for its costs to participate in the Witness Test. Operation of the Community Solar Project requires an effective Interconnection Agreement; electricity sales require a power purchase agreement.

To the extent that the Interconnection Customer decides to conduct interim testing of the Community Solar Project prior to the Witness Test, it may request that the Public Utility observe these tests. If the Public Utility agrees to send qualified personnel to observe any interim testing proposed by the Interconnection Customer, the Interconnection Customer shall pay or reimburse the Public Utility for its cost to participate in the interim testing. If the Interconnection Customer conducts interim testing and such testing is observed by the Public Utility and the results of such interim testing are deemed acceptable by the Public Utility (hereinafter a "Public Utility-approved interim test"), then the Interconnection Customer may request that such Public Utility-approved interim test be deleted from the final Witness Testing. If the Public Utility elects to repeat any Public Utility-approved interim test as part of the final Witness Test, the Public Utility will bare its own expenses associated with participation in the repeated Public Utility-approved interim test.

#### **2.2 Right of Access:**

As provided in the CSP Interconnection Procedures, the Public Utility will have access to the Interconnection Customer's premises for any reasonable purpose in connection with the Interconnection Application or any Interconnection Agreement that is entered in to pursuant to the Rule and CSP Interconnection Procedures or if necessary to meet the legal obligation to provide service to its customers. Access will be requested at reasonable hours and upon reasonable notice, or at any time without notice in the event of an emergency or hazardous condition.



## **Interconnection Agreement for a Community Solar Project**

### **Article 3. Effective Date, Term, Termination, and Disconnection**

#### **3.1 Effective Date**

The Agreement shall become effective upon execution by the Parties.

#### **3.2 Term of Agreement**

The Agreement will be effective on the Effective Date and will remain in effect for a period of twenty (20) years from the commercial operations date or the life of the power purchase agreement, whichever is shorter.

#### **3.3 Termination**

No termination will become effective until the Parties have complied with all provisions of the CSP Interconnection Procedures and this Agreement that apply to such termination.

3.3.1 The Interconnection Customer may terminate this Agreement at any time by giving the Public Utility twenty (20) Business Days written notice.

3.3.2 Either Party may terminate this Agreement after default pursuant to Article 5.6 of this Agreement.

3.3.3 The Commission may order termination of this Agreement.

3.3.4 Upon termination of this Agreement, the Community Solar Project will be disconnected from the Public Utility's Distribution System at the Interconnection Customer's expense. The termination of this Agreement will not relieve either Party of its liabilities and obligations, owed or continuing at the time of the termination.

3.3.5 The provisions of this Article 3.3 shall survive termination or expiration of this Agreement.

#### **3.4 Temporary Disconnection**

The Public Utility or Interconnection Customer may temporarily disconnect the Community Solar Project from the Public Utility's Distribution System for so long as reasonably necessary, as provided in the CSP Interconnection Procedures, in the event one or more of the following conditions or events occurs:

3.4.1 Under emergency conditions, the Public Utility or the Interconnection Customer may immediately suspend interconnection service and temporarily disconnect the Community Solar Project without advance notice to the other Party. The Public Utility shall notify the Interconnection Customer promptly when it becomes aware of an emergency condition that may reasonably be expected to affect the Community Solar Project operation. The Interconnection Customer will notify the Public Utility promptly when it becomes aware of an emergency condition that may reasonably be expected to affect the Public Utility's Distribution System. To the extent information is known, the notification shall describe the emergency condition, the extent of the



## Interconnection Agreement for a Community Solar Project

damage or deficiency, the expected effect on the operation of both Parties' facilities and operations, its anticipated duration, and the necessary corrective action.

- 3.4.2 For routine Maintenance, Parties will make reasonable efforts to provide five Business Days' notice prior to interruption caused by routine maintenance or construction and repair to the Community Solar Project or Public Utility's Distribution System and shall use reasonable efforts to coordinate such interruption.
- 3.4.3 The Public Utility shall use reasonable efforts to provide the Interconnection Customer with prior notice of forced outages of the Distribution System. If prior notice is not given, the Public Utility shall, upon request, provide the Interconnection Customer written documentation after the fact explaining the circumstances of the disconnection.
- 3.4.4 For disruption or deterioration of service, where the Public Utility determines that operation of the Community Solar Project will likely cause disruption or deterioration of service to other customers served from the same electric system, or if operating the Community Solar Project could cause damage to the Public Utility's Distribution System, the Public Utility may disconnect the Community Solar Project. The Public Utility will provide the Interconnection Customer upon request all supporting documentation used to reach the decision to disconnect. The Public Utility may disconnect the Community Solar Project if, after receipt of the notice, the Interconnection Customer fails to remedy the adverse operating effect within a reasonable time which shall be at least five Business Days from the date the Interconnection Customer receives the Public Utility's written notice supporting the decision to disconnect, unless emergency conditions exist, in which case the provisions of 3.4.1 of the agreement apply.

### **3.5 Restoration of interconnection:**

The Parties shall cooperate with each other to restore the Community Solar Project, Interconnection Facilities, and Public Utility's Distribution System to their normal operating state as soon as reasonably practicable following any disconnection pursuant to Article 3.4.

## **Article 4. Cost Responsibility and Billing:**

As provided in the CSP Interconnection Procedures, the Applicant is responsible for the cost of all facilities, equipment, modifications and upgrades needed to facilitate the interconnection of the Community Solar Project to the Public Utility's Distribution System.

### **4.1 Minor Distribution System Modifications:**

As provided in the CSP Interconnection Procedures addressing Tier 2 review, it may be necessary for the Parties to construct certain Minor Modifications to interconnect under Tier 2 review. The Public Utility has itemized any required Minor Modifications in the



## **Interconnection Agreement for a Community Solar Project**

attachments to this Agreement, including a good-faith estimate of the cost of such Minor Modifications and the time required to build and install such Minor Modifications. The Interconnection Customer agrees to pay the costs of such Minor Modifications.

### **4.2 Interconnection Facilities:**

The Public Utility has identified under the review procedures of a Tier 2 review or under a Tier 4 Facilities Study, the Interconnection Facilities necessary to safely interconnect the Community Solar Project with the Public Utility. The Public Utility has itemized the required Interconnection Facilities in the attachments to this Agreement, including a good-faith estimate of the cost of the facilities and the time required to build and install those facilities. The Applicant is responsible for the cost of the Interconnection Facilities.

### **4.3 Interconnection Equipment:**

The Applicant is responsible for all reasonable expenses, including overheads, associated with owning, operating, maintaining, repairing, and replacing its Interconnection Equipment.

### **4.4 System Upgrades:**

The Public Utility will design, procure, construct, install, and own any System Upgrades. The actual cost of the System Upgrades, including overheads, will be directly assigned to an Applicant. In such cases when there are multiple Community Solar Facilities on a single circuit of the Distribution System that are jointly studied, the Public Utility shall allocate the System Upgrade costs based on the proportional capacity of each Community Solar Project. The cost sharing will be detailed in the Attachments to this Agreement. If a Community Solar Project that has been jointly studied and allocated a share of system upgrade costs withdraws, the Company will reassess the System Upgrades needed to complete the interconnection(s) and reallocate the System Upgrade costs to the remaining Community Solar Project(s) using the same methodology.

### **4.5 Adverse System Impact:**

The Public Utility is responsible for identifying the possible Affected Systems and coordinating with those identified Affected Systems, to the extent reasonably practicable, to allow the Affected System owner an opportunity to identify Adverse System Impacts on its Affected System, and to identify what mitigation activities or upgrades may be required on the Public Utility's system or on the Affected System to address impacts on Affected Systems and accommodate a Community Solar Project. Such coordination with Affected System owners shall include inviting Affected System owners to scoping meetings between the Public Utility and the Applicant and providing the Affected System owner with study results and other information reasonably required and requested by the Affected System owner to allow the Affected System owner to assess impacts to its system and determine required mitigation, if any, for such impacts. The Parties acknowledge that the Public Utility cannot compel the participation of the Affected System owner and that the Public Utility is not itself responsible for identifying impacts or mitigation associated with an Affected System. The actual cost of any actions taken to address the Adverse System Impacts, including overheads, shall be directly assigned to the Interconnection Customer. The



## Interconnection Agreement for a Community Solar Project

Interconnection Customer may be entitled to financial compensation from other Public Utilities or other Interconnection Customers who, in the future, utilize the upgrades paid for by the Interconnection Customer, to the extent allowed or required by the Commission. Such compensation will only be available to the extent provided for in the separate rules or Commission order. If the Parties have actual knowledge of an Adverse System Impact on an Affected System, the Applicant shall not interconnect and operate its Community Solar Project in parallel with the Public Utility's system, and the Public Utility shall not authorize or allow the continued interconnection or parallel operation of the Community Solar Project, unless and until such Adverse System Impact has been addressed to the reasonable satisfaction of the Affected System owner.

### 4.6 Deposit and Billings:

The Applicant agrees to pay to the Public Utility a deposit toward the cost to construct and install any required Interconnection Facilities and/or System Upgrades. The amount of the deposit shall be (select one of the following):

The Parties have agreed to progress payments and final payment under the schedule of payments attached to this Agreement; the Applicant shall pay a deposit equal to the lesser of (a) 25 percent of the estimated cost of the Interconnection Facilities and System Upgrades, or (b) \$10,000 – the amount of the deposit shall be \$10,000.

or

The Parties have not agreed to progress payments, the Applicant shall pay 100% of estimated costs as detailed in the Attachments to this agreement prior to the commencement of work.

If the actual costs of Interconnection Facilities and/or System Upgrades are different than the deposit amounts and/or progress and final payments provided for above, then the Applicant shall pay the Public Utility any balance owing or the Public Utility shall refund any excess deposit or progress payment within 20 Business Days of the date actual costs are determined.

If the Applicant's request to interconnect was jointly studied by the Company and the Applicant withdrawals, then any deposits or payments made by the withdrawing Applicant will be applied as a bill credit to not-yet-invoiced study costs for other remaining CSP Applicants that were jointly studied. Any remaining deposits or payments after the bill credits have been issued will be returned to the withdrawing Applicant.

## **Article 5. Assignment, Liability, Indemnity, Force Majeure, Consequential Damages, and Default**

### 5.1 Assignment

The Interconnection Agreement may be assigned by either Party upon fifteen (15) Business Days prior written notice. Except as provided in Articles 5.1.1 and 5.1.2, said assignment





## Interconnection Agreement for a Community Solar Project

shall only be valid upon the prior written consent of the non-assigning Party, which consent shall not be unreasonably withheld.

- 5.1.1 Either Party may assign the Agreement without the consent of the other Party to any affiliate (which shall include a merger of the Party with another entity), of the assigning Party with an equal or greater credit rating and with the legal authority and operational ability to satisfy the obligations of the assigning Party under this Agreement;
- 5.1.2 The Interconnection Customer shall have the right to assign the Agreement, without the consent of the Public Utility, for collateral security purposes to aid in providing financing for the Community Solar Project. For Community Solar Project systems that are integrated into a building facility, the sale of the building or property will result in an automatic transfer of this agreement to the new owner who shall be responsible for complying with the terms and conditions of this Agreement.
- 5.1.3 Any attempted assignment that violates this Article is void and ineffective. Assignment shall not relieve a Party of its obligations, nor shall a Party's obligations be enlarged, in whole or in part, by reason thereof. An assignee is responsible for meeting the same obligations as the assigning Interconnection Customer.
- 5.1.4 Any assignment not specifically approved by the Project Manager or the Program Administrator shall similarly be declared void and ineffective.

### **5.2 Limitation of Liability and Consequential Damages**

A Party is liable for any loss, cost claim, injury, or expense including reasonable attorney's fees related to or arising from any act or omission in its performance of the provisions of this Agreement entered into pursuant to the Rule except as provided for in ORS 757.300(4)(c). Neither Party will seek redress from the other Party in an amount greater than the amount of direct damage actually incurred.

### **5.3 Indemnity**

- 5.3.1 Liability under this Article 5.3 is exempt from the general limitations on liability found in Article 5.2.
- 5.3.2 The Parties shall at all times indemnify, defend, and hold the other Party harmless from, any and all damages, losses, claims, including claims and actions relating to injury to or death of any person or damage to property, demand, suits, recoveries, costs and expenses, court costs, attorney fees, and all other obligations by or to third parties, arising out of or resulting from the other Party's action or failure to meet its obligations under this Agreement on behalf of the indemnifying party, except in cases of gross negligence or intentional wrongdoing by the indemnified person.

## **Interconnection Agreement for a Community Solar Project**

- 5.3.3 If an indemnified person is entitled to indemnification under this Article 5.3 as a result of a claim by a third party, and the indemnifying party fails, after notice and reasonable opportunity to proceed under this Article 5.3, to assume the defense of such a claim, such indemnified person may at the expense of the indemnifying Party contest, settle or consent to the entry of any judgment with respect to, or pay in full, such claim.
- 5.3.4 If an indemnifying party is obligated to indemnify and hold any indemnified person harmless under this Article 5.3, the amount owing to the indemnified person shall be the amount of such indemnified person's actual loss, net of any insurance or other recovery.
- 5.3.5 Promptly after receipt by an indemnified person of any claim or notice of the commencement of any action or administrative or legal proceeding or investigation as to which the indemnity provided for in this Article 5.3 may apply, the indemnified person shall notify the indemnifying party of such fact. Any failure of or delay in such notification shall not affect a Party's indemnification obligation unless such failure or delay is materially prejudicial to the indemnifying party.
- 5.3.6 The indemnifying party shall have the right to assume the defense thereof with counsel designated by such indemnifying party and reasonably satisfactory to the indemnified person. If the defendants in any such action include one or more indemnified persons and the indemnifying party and if the indemnified person reasonably concludes that there may be legal defenses available to it and/or other indemnified persons which are different from or additional to those available to the indemnifying party, the indemnified person shall have the right to select separate counsel to assert such legal defenses and to otherwise participate in the defense of such action on its own behalf. In such instances, the indemnifying party shall only be required to pay the fees and expenses of one additional attorney to represent an indemnified person or indemnified persons having such differing or additional legal defenses.
- 5.3.7 The indemnified person shall be entitled, at its expense, to participate in any such action, suit or proceeding, the defense of which has been assumed by the indemnifying party. Notwithstanding the foregoing, the indemnifying party (i) shall not be entitled to assume and control the defense of any such action, suit or proceedings if and to the extent that, in the opinion of the indemnified person and its counsel, such action, suit or proceeding involves the potential imposition of criminal liability on the indemnified person, or there exists a conflict or adversity of interest between the indemnified person and the indemnifying Party, in such event the indemnifying Party shall pay the reasonable expenses of the indemnified person, and (ii) shall not settle or consent to the entry of any judgment in any action, suit or proceeding without the consent of the indemnified person, which shall not be reasonably withheld, conditioned or delayed.

## **Interconnection Agreement for a Community Solar Project**

### **5.4 Consequential Damages**

Neither Party shall be liable to the other Party, under any provision of this Agreement, for any losses, damages, costs or expenses for any special, indirect, incidental, consequential, or punitive damages, including but not limited to loss of profit or revenue, loss of the use of equipment, cost of capital, cost of temporary equipment or services, whether based in whole or in part in contract, in tort, including negligence, strict liability, or any other theory of liability; provided, however, that damages for which a Party may be liable to the other Party under another agreement will not be considered to be special, indirect, incidental, or consequential damages hereunder.

### **5.5 Force Majeure**

5.5.1 As used in this Agreement, a Force Majeure Event shall mean “any act of God, labor disturbance, act of the public enemy, war, acts of terrorism, insurrection, riot, fire, storm or flood, explosion, breakage or accident to machinery or equipment through no direct, indirect, or contributory act of a Party, any order, regulation or restriction imposed by governmental, military or lawfully established civilian authorities, or any other cause beyond a Party’s control. A Force Majeure Event does not include an act of negligence or intentional wrongdoing.”

5.5.2 If a Force Majeure Event prevents a Party from fulfilling any obligations under this Agreement, the Party affected by the Force Majeure Event (Affected Party) shall promptly notify the other Party of the existence of the Force Majeure Event. The notification must specify in reasonable detail the circumstances of the Force Majeure Event, its expected duration, and the steps that the Affected Party is taking to mitigate the effects of the event on its performance, and if the initial notification was verbal, it should be promptly followed up with a written notification. The Affected Party shall keep the other Party informed on a continuing basis of developments relating to the Force Majeure Event. Until the Force Majeure Event ends the Affected Party will be entitled to suspend or modify its performance of obligations under this Agreement (other than the obligation to make payments) only to the extent that the effect of the Force Majeure Event cannot be reasonably mitigated. The Affected Party will use reasonable efforts to resume its performance as soon as possible. The Parties shall immediately report to the Commission should a Force Majeure Event prevent performance of an action required by the Rule that the Rule does not permit the Parties to mutually waive.

### **5.6 Default**

5.6.1 No default shall exist where such failure to discharge an obligation (other than the payment of money) is the result of a Force Majeure Event as defined in this Agreement, or the result of an act or omission of the other Party. Upon a breach, the non-breaching Party shall give written notice of such breach to the breaching Party. Except as provided in Article 5.6.2, the breaching Party shall have sixty (60) Calendar Days from receipt of the beach notice within which to cure such breach;



## Interconnection Agreement for a Community Solar Project

provided however, if such breach is not capable of cure within 60 Calendar Days, the breaching Party shall commence such cure within twenty (20) Calendar Days after notice and continuously and diligently complete such cure within six months from receipt of the breach notice; and, if cured within such time, the breach specified in such notice shall cease to exist.

- 5.6.2 If a breach is not cured as provided for in this Article 5.6, or if a breach is not capable of being cured within the period provided for herein, the non-breaching Party shall have the right to declare a default and terminate this Agreement by written notice at any time until cure occurs, and be relieved of any further obligation hereunder and, whether or not that Party terminates this Agreement, to recover from the breaching Party all amounts due hereunder, plus all other damages and remedies to which it is entitled at law or in equity. Alternatively, the non-breaching Party shall have the right to seek dispute resolution with the Commission in lieu of default. The provisions of this Article 5.6 will survive termination of the Agreement.

### **Article 6. Insurance**

- 6.1** The Public Utility may not require the Community Solar Project to maintain general liability insurance in relation to the interconnection of the Community Solar Project with an Electric Nameplate Capacity of 200 kW or less. With regard to the interconnection of a Community Solar Project, the Interconnection Customer shall, at its own expense, maintain in force throughout the period of this Agreement general liability insurance sufficient to protect any person (including the Public Utility) who may be affected by the Interconnection Customer's Community Solar Project and its operation and such insurance shall be sufficient to satisfy the Interconnection Customer's indemnification responsibilities under Article 5.3 of this Agreement.
- 6.2** Within ten (10) days following execution of this Agreement, and as soon as practicable after the end of each fiscal year or at the renewal of the insurance policy and in any event within ninety (90) days thereafter, the Interconnection Customer shall provide the Public Utility with certification of all insurance required in this Agreement, executed by each insurer or by an authorized representative of each insurer.
- 6.3** All insurance required by this Article 6 shall name the Public, its parent, associated and Affiliate companies and their respective directors, officers, agents, servants and employees ("Other Party Group") as additional insured. All policies shall contain provisions whereby the insurers waive all rights of subrogation against the Other Party Group and provide thirty (30) Calendar Days advance written notice to the Other Party Group prior to anniversary date of cancellation or any material change in coverage or condition. The Interconnection Customer's insurance shall contain provisions that specify that the policies are primary and shall apply to such extent without consideration for other policies separately carried and shall state that each insured is provided coverage as though a separate policy had been issued to each, except the insurer's liability shall not be increased beyond the amount for which the insurer would have been liable had only one insured been covered. The insurance policies,



## **Interconnection Agreement for a Community Solar Project**

if written on a Claims First Made Basis, shall be maintained in full force and effect for two (2) years after termination of this Agreement, which coverage may be in the form of tail coverage or extended reporting period coverage if agreed by the Parties.

- 6.4** The Parties agree to report to each other in writing as soon as practical all accidents or occurrences resulting in injuries to any person, including death, and any property damage arising out of this Agreement.
- 6.5** The requirements contained herein as to insurance are not intended to and shall not in any manner, limit or qualify the liabilities and obligations assumed by the Parties under this Agreement.

### **Article 7. Dispute Resolution**

Parties will adhere to the dispute resolution provisions in the CSP Interconnection Procedures.

### **Article 8. Miscellaneous**

#### **8.1 Governing Law, Regulatory Authority, and Rules**

The validity, interpretation and enforcement of the Agreement and each of its provisions shall be governed by the laws of the State of Oregon, without regard to its conflicts of law principles. The Agreement is subject to all applicable laws. Each Party expressly reserves the right to seek changes in, appeal, or otherwise contest any laws, orders, or regulations of a governmental authority.

#### **8.2 Amendment**

The Parties may mutually agree to amend the Agreement by a written instrument duly executed by both Parties in accordance with provisions of the Rule and applicable Commission Orders and provisions of the laws if the State of Oregon.

#### **8.3 No Third-Party Beneficiaries**

The Agreement is not intended to and does not create rights, remedies, or benefits of any character whatsoever in favor of any persons, corporations, associations, or entities other than the Parties, and the obligations herein assumed are solely for the use and benefit of the Parties, their successors in interest and where permitted, their assigns.

#### **8.4 Waiver**

- 8.4.1** The failure of a Party to the Agreement to insist, on any occasion, upon strict performance of any provision of the Agreement will not be considered a waiver of any obligation, right, or duty of, or imposed upon, such Party.
- 8.4.2** The Parties may agree to mutually waive a section of this Agreement so long as prior Commission approval of the waiver is not required by the Rule.



## **Interconnection Agreement for a Community Solar Project**

8.4.3 Any waiver at any time by either Party of its rights with respect to the Agreement shall not be deemed a continuing waiver or a waiver with respect to any other failure to comply with any other obligation, right, duty of the Agreement. Any waiver of the Agreement shall, if requested, be provided in writing.

### **8.5 Entire Agreement**

This Agreement, including any supplementary Form attachments that may be necessary, constitutes the entire agreement between the Parties with reference to the subject matter hereof, and supersedes all prior and contemporaneous understandings or agreements, oral or written, between the Parties with respect to the subject matter of the Agreement. There are no other agreements, representations, warranties, or covenants that constitute any part of the consideration for, or any condition to, either Party's compliance with its obligations under this Agreement.

### **8.6 Multiple Counterparts**

This Agreement may be executed in two or more counterparts, each of which is deemed an original but all constitute one and the same instrument.

### **8.7 No Partnership**

This Agreement will not be interpreted or construed to create an association, joint venture, agency relationship, or partnership between the Parties or to impose any partnership obligation or partnership liability upon either Party. Neither Party shall have any right, power or authority to enter into any agreement or undertaking for, or act on behalf of, or to act as or be an agent or representative of, or to otherwise bind, the other Party.

### **8.8 Severability**

If any provision or portion of this Agreement shall for any reason be held or adjudged to be invalid or illegal or unenforceable by any court of competent jurisdiction or other governmental authority; (1) such portion or provision shall be deemed separate and independent; (2) the Parties shall negotiate in good faith to restore insofar as practicable the benefits to each Party that were affected by such ruling; and (3) the remainder of this Agreement shall remain in full force and effect.

### **8.9 Subcontractors**

Nothing in this Agreement shall prevent a Party from utilizing the services of any subcontractor, or designating a third party agent as one responsible for a specific obligation or act required in this Agreement (collectively subcontractors), as it deems appropriate to perform its obligations under this Agreement; provided, however, that each Party will require its subcontractors to comply with all applicable terms and conditions of this Agreement in providing such services and each Party will remain primarily liable to the other Party for the performance of such subcontractor.

8.9.1 The creation of any subcontract relationship shall not relieve the hiring Party of any of its obligations under this Agreement. The hiring Party shall be fully responsible to the other Party for the acts or omissions of any subcontractor the hiring Party hires



## Interconnection Agreement for a Community Solar Project

as if no subcontract had been made. Any applicable obligation imposed by this Agreement upon the hiring Party shall be equally binding upon, and will be construed as having application to, any subcontractor of such Party.

8.9.2 The obligations under this Article 8.9 will not be limited in any way by any limitation of subcontractor's insurance.

### 8.10 Reservation of Rights

Either Party will have the right to make a unilateral filing with the Commission to modify this Agreement. This reservation of rights provision will include but is not limited to modifications with respect to any rates terms and conditions, charges, classification of service, rule or regulation under CSP Interconnection Procedures rates or any applicable State or Federal law or regulation. Each Party shall have the right to protest any such filing and to participate fully in any proceeding before the Commission in which such modifications may be considered.

## Article 9. Notices and Records

### 9.1 General

Unless otherwise provided in this Agreement, any written notice, demand, or request required or authorized in connection with this Agreement shall be deemed properly given if delivered in person, delivered by recognized national courier service, or sent by first class mail, postage prepaid, to the person specified below:

### 9.2 Records

The Public Utility will maintain a record of all Interconnection Agreements and related Form attachments for as long as the interconnection is in place as required by the CSP Interconnection Procedures. The Public Utility will provide a copy of these records to the Interconnection Customer within 15 Business Days if a request is made in writing.

#### **If to the Interconnection Customer:**

Interconnection Customer: Sunthurst Energy, LLC

Attention: Daniel Hale

Address: 43682 SW Brower Ln

City: Pendleton State: OR Zip: 97801

Phone: 310-975-4732 E-mail: daniel@sunthurstenergy.com

#### **If to Public Utility:**

Public Utility: PacifiCorp

Attention: Transmission Services

Address: 825 N.E. Multnomah Street, Suite 550

City: Portland State: OR Zip: 97232

Phone: 503-813-6077 Fax: 503-813-6873



## Interconnection Agreement for a Community Solar Project

### 9.3 Billing and Payment

Billings and payments shall be sent to the addresses set out below: (complete if different than article 9.2 above)

**If to the Interconnection Customer**

Same as 9.2

**If to Public Utility**

Public Utility: PacifiCorp Transmission

Attention: Central Cashiers Office

Address: 825 N.E. Multnomah Street, Suite 550

City: Portland State: OR Zip: 97232

### 9.4 Designated Operating Representative

The Parties will designate operating representatives to conduct the communications which may be necessary or convenient for the administration of the operations provisions of this Agreement. This person will also serve as the point of contact with respect to operations and maintenance of the Party's facilities (complete if different than article 9.2 above)

**Interconnection Customer's Operating Representative:**

Same as 9.2

**Public Utility's Operating Representative:** PacifiCorp

Attention: Grid Operations

Address: 9915 S.E. Ankeny Street

City: Portland State: OR Zip: 97216

Phone: 503-251-5197 Fax: 503-251-5228

### 9.5 Changes to the Notice Information

Either Party may change this notice information by giving five Business Days written notice prior to the effective date of the change.





## Interconnection Agreement for a Community Solar Project

### Article 10. Signatures

IN WITNESS WHEREOF, the Parties have caused this Agreement to be executed by their respective duly authorized representatives.

#### For Public Utility:

Name:                     Rick Vail                     Digitally signed by Rick Vail  
Date: 2021.12.28 06:27:02 -08'00'

                    Rick Vail

Title: VP, Transmission

Date: 12/28/2021

#### For the Applicant/Interconnection Customer:

Name:                     D Hale                    

                    Daniel Hale,

Title: Owner

Date: 12/24/2021



## Interconnection Agreement for a Community Solar Project

### Attachment 1

#### Description of Interconnection Facilities And Metering Equipment Operated or Maintained by the Public Utility

**Community Solar Project:** Twenty-six (26) Sungrow SG60KU-M 60 kW inverters for a total nameplate output of 1.56 MW. The 26 inverters are connected to a 3000A 480Y/277V switchboard. The switchboard is fed from a 2000 kVA 12.47Y/7.2kV-480Y/277V transformer with an impedance of about 5.75%. A single 200 kVA 480Y/277V-240/120V 5.75% grounding transformer is connected to a 480Y/277V switchboard through a 600A circuit breaker. See Attachment 2.

**Interconnection Customer Interconnection Facilities:** A single relay-controlled recloser (with transfer trip control), conductor (with appurtenant facilities), and Public Utility accessible disconnect switch. See Attachment 2.

**Public Utility's Interconnection Facilities:** Bi-Directional metering, radio communications for transfer trip, disconnect switch, and appurtenant structures to line-tap. See Attachment 2.

**Estimated Cost of Public Utility's Interconnection Facilities:** Estimated cost of Public Utility's Interconnection Facilities directly assigned to Interconnection Customer: \$87,000.

**Estimated Annual Operation and Maintenance Cost of Public Utility's Interconnection Facilities:** \$750. Interconnection Customer shall be responsible for Public Utility's actual cost for maintenance of the Public Utility's Interconnection Facilities.

**Point of Interconnection:** The point where the Public Utility's Interconnection Facilities connect to the Public Utility's 12.5 kV distribution circuit 5W857 out of McKay substation. See Attachment 2.

**Point of Change of Ownership:** The point where the Interconnection Customer's Interconnection Facilities connect to the Public Utility's Interconnection Facilities. See Attachment 2.

# Interconnection Agreement for a Community Solar Project

## Attachment 2

### One-line Diagram Depicting the Generating Facility, Interconnection Facilities, and Metering Equipment

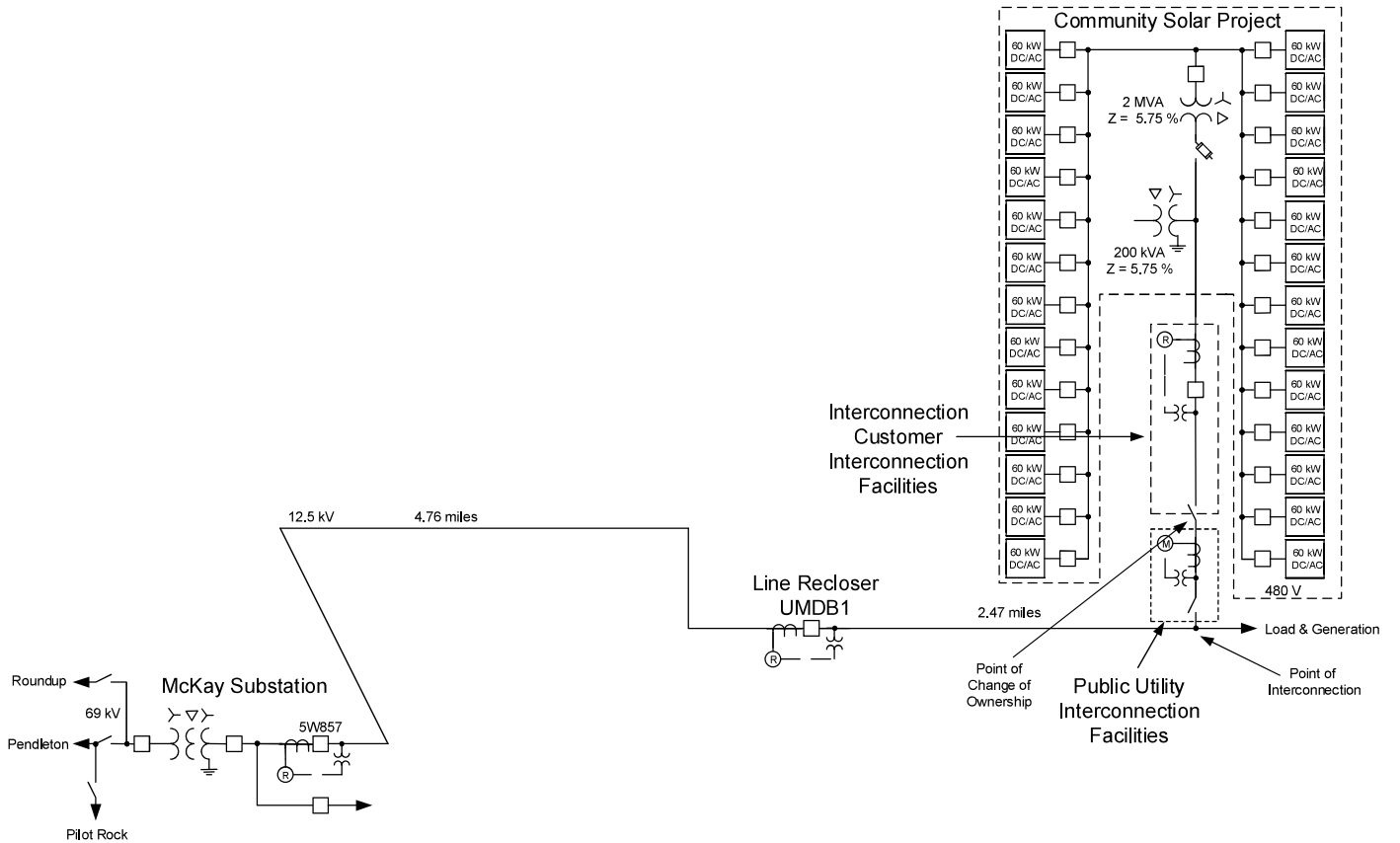



## Interconnection Agreement for a Community Solar Project

### Attachment 3

#### Milestones

Estimated In-Service Date: December 30, 2022

Critical milestones and responsibility as agreed to by the Parties:

	<b>Milestone/Date</b>	<b>Responsible Party</b>
(1)	<u>Execute Agreement and Provide First Pre-Payment</u> December 28, 2021	<u>Applicant</u>
(2)	<u>Retail Service Request Established</u> January 7, 2022	<u>Both</u>
*(3)	<u>Provide Initial Design Package</u> January 21, 2022	<u>Applicant</u>
(4)	<u>Commence Engineering and Procurement</u> February 7, 2022	<u>Public Utility</u>
(5)	<u>Property/Permits/RoW Procured</u> March 4, 2022	<u>Applicant</u>
*(6)	<u>Final Design Package Provided</u> April 22, 2022	<u>Applicant</u>
(7)	<u>Engineering Design Complete</u> August 19, 2022	<u>Public Utility</u>
(8)	<u>Begin Construction</u> September 19, 2022	<u>Public Utility</u>
(9)	<u>Provide Maintenance &amp; Commissioning Plans</u> September 2, 2022	<u>Applicant</u>
(10)	<u>Construction Complete</u> November 22, 2022	<u>Both Parties</u>
(11)	<u>Commissioning Activities Complete</u> December 20, 2022	<u>Public Utility</u>
(12)	<u>Commissioning Document Review Complete</u> December 27, 2022	<u>Public Utility</u>



## Interconnection Agreement for a Community Solar Project

- |      |  |                                 |
|------|--|---------------------------------|
| (13) | <u>Backfeed</u><br>December 28, 2022                                   | <u>Applicant</u>                |
| (14) | <u>Initial Synchronization/Generation Testing</u><br>December 29, 2022 | <u>Applicant</u>                |
| (15) | <u>Commercial Operations</u><br>December 30, 2022                      | <u>Interconnection Customer</u> |

Interconnection Customer is to request Backfeed, 1<sup>st</sup> Sync, and Commercial Operations in writing (email acceptable) prior to the above dates. Public Utility is to approve Interconnection Customer requests without unreasonable delay. The Interconnection Customer will be required to demonstrate the reactive capability of the Community Solar Project and the voltage control system prior to Commercial Operations.

\*Applicant initial design package shall include final generating facility location, inverter selection, basic protection package and collector system location. Applicant final design package shall include PE stamped issued for construction (“IFC”) drawings for generating facility and collector substation.

### Payment Schedule\*

If Interconnection Customer agrees to progress payments option under Article 4.6 of the Interconnection Agreement, there are two potential options for a payment schedule below (please select one). If Interconnection Customer elects progress payment option but an option below is not selected, the Levelized Option will be selected by default. Failure to comply with the selected payment schedule will result in contractual breach, work stoppage, and slip of the milestone schedule above on a day-for-day basis. Interconnection Customer will still be responsible for all costs of the project. Public Utility will conduct initial accounting for the project within thirty (30) days of granting Commercial Operations approval and will determine if a partial refund of project costs is acceptable.

Please select an option:	<input type="checkbox"/>	<input checked="" type="checkbox"/>
<u>Funds due no later than</u> December 28, 2021 (or when Interconnection Agreement is executed)	<u>Levelized Option</u>	<u>Stepped Option</u>
January 1, 2022	\$10,000	\$10,000
March 30, 2022	\$70,750	\$15,000
July 1, 2022	\$70,750	\$25,000
September 1, 2022	\$70,750	\$160,000
	\$70,750	\$83,000

\*Please see Attachments 5 and 6 for further information as estimated costs may change during detailed engineering.



## Interconnection Agreement for a Community Solar Project

### Attachment 4

#### **Additional Operating Requirements for the Public Utility's Transmission System and/or Distribution System and Affected Systems Needed to Support the Interconnection Customer's Needs**

The interconnection of the Community Solar Project is subject to the rules contained within the CSP Interconnection Procedures. The interconnection of the Community Solar Project to the Public Utility's Distribution System shall be subject to, and the Interconnection Customer shall operate the Community Solar Project in accordance with, the Public Utility's policies governing interconnection of generation facilities to the Distribution System entitled "Facility Connection (Interconnection) Requirements for Distribution Systems (34.5 kV and below)" which policy document is available upon request from the Public Utility and is incorporated by this reference as part of the Interconnection Agreement between the Parties. In the event of a conflict between any aspect of this Attachment 4 (including without limitation the Public Utility's policies governing interconnection of generation facilities to the distribution system or the transmission system) and the rules contained in the CSP Interconnection Procedures, the rules shall prevail.

Parallel Operation. Interconnection Customer may operate the Community Solar Project in parallel with the Public Utility's Transmission System or Distribution System (collectively the "Electrical System"), but subject at all times to any operating instructions that the Public Utility's dispatch operators may issue and in accordance with all the provisions of this Interconnection Agreement and Good Utility Practice, and any other conditions imposed by the Public Utility in its sole discretion.

Community Solar Project Operation Shall Not Adversely Affect the Public Utility's Distribution System. Interconnection Customer shall operate the Community Solar Project in such a manner as not to adversely affect the Public Utility's Distribution System or any other element of the Public Utility's electrical system. Interconnection Customer's Community Solar Project shall deliver not more than the Design Capacity of 1.56 MW. Except as otherwise required by this Interconnection Agreement, Interconnection Customer shall operate the Community Solar Project in a manner compatible with the Public Utility's applicable voltage level and fluctuating voltage guidelines, entitled Facility Connection (Interconnection) Requirements for Distribution Systems (34.5 kV and below), as it may be amended or superseded from time to time in the Public Utility's reasonable discretion, at the Point of Interconnection during all times that the Community Solar Project is connected and operating in parallel with the Public Utility's Distribution System. In its sole discretion, the Public Utility may specify rates of change in Interconnection Customer's deliveries to the Public Utility's Distribution System during any start-up of the Community Solar Project, during reconnection to the Public Utility's Distribution System, and during normal operations to assure that such rates of change are compatible with the operation of the Public Utility's voltage regulation equipment.

Maximum Authorized Power Flow. The Community Solar Project shall not be operated in a manner that results in the flow of electric power onto the Public Utility's Distribution System during any fifteen (15) minute interval at levels in excess of 1,642 kVA from the Community Solar Project. If this provision is violated, the Public Utility may terminate this Interconnection Agreement or lock the Interconnection Customer Disconnect Switch in the open position until such time as: (a) the Public Utility has studied the impact of additional generation on the Distribution System (at Interconnection Customer's cost and pursuant to a new study agreement between the Public Utility and Interconnection Customer) and the



## Interconnection Agreement for a Community Solar Project

interconnection has been upgraded (at Interconnection Customer's cost and pursuant to a new or amended Facilities Construction Agreement and a new or amended Interconnection Agreement if deemed necessary by the Public Utility) in any manner necessary to accommodate the additional generation; or (b) the Interconnection Customer has modified the Community Solar Project or Interconnection Customer's Interconnection Facilities in such manner as to insure to the Public Utility's satisfaction that the Community Solar Project will no longer cause electric power to flow onto the Public Utility's Distribution System at a level in excess of 1,642 kVA.

Harmonic Distortion or Voltage Flicker. Notwithstanding the Study Results, upon notice from the Public Utility that operation of the Community Solar Project is producing unacceptable harmonic distortions or voltage flicker on the Public Utility's Distribution System, Interconnection Customer shall at its sole cost remedy such harmonic distortions or voltage flicker within a reasonable time.

Reactive Power. Generators shall be capable of operating under Voltage-reactive power mode, Active power-reactive power mode, and Constant reactive power mode as per IEEE Std. 1547. This project shall be capable of activating each of these modes one at a time. The Public Utility reserves the right to specify any mode and settings within the limits of IEEE Std 1547 needed before or after the Community Solar Project enters service. The Applicant shall be responsible for implementing settings modifications and mode selections as requested by the Public Utility within an acceptable timeframe. The reactive compensation must be designed such that the discreet switching of the reactive device (if required by the Applicant) does not cause step voltage changes greater than +/-3% on the Public Utility's system. In all cases the minimum power quality requirements in PacifiCorp's Engineering Handbook section 1C shall be met and are available at <https://www.pacificpower.net/about/power-quality-standards.html>. Requirements specified in the System Impact Study that exceed requirements in the Engineering Handbook section 1C power quality standards shall apply.

Islanding. If at any time during the term of this Interconnection Agreement the interconnection of the Community Solar Project to the Public Utility's Distribution System results in a risk of electrical islanding, or actual occurrences of electrical islanding, which the Public Utility reasonably concludes are incompatible with Good Utility Practice, the Parties shall (as necessary) study the issue and implement a solution that will eliminate or mitigate the risk of electrical islanding to a level deemed acceptable by the Public Utility. All costs associated with addressing any electrical islanding problems as required by this paragraph shall be paid by the Interconnection Customer, including without limitation any study costs, engineering costs, design costs, or costs to procure, install, operate and/or maintain required interconnection facilities or protective devices.

Voltage Regulation. The Community Solar Project and Interconnection Equipment owned by the Applicant are required to operate under constant power factor mode with a unity power factor setting unless specifically requested otherwise by the Public Utility.. The Community Solar Project is expressly forbidden from actively participating in voltage regulation of the Public Utilities system without written request or authorization from the Public Utility. The Community Solar Project shall have sufficient reactive capacity to enable the delivery of 100 percent of the plant output to the POI at unity power factor measured at 1.0 per unit voltage under steady state conditions.



## Interconnection Agreement for a Community Solar Project

Modification of Nominal Operating Voltage Level. By providing Interconnection Customer with a one hundred and eighty (180) day notice, the Public Utility may at its sole discretion change the Public Utility's nominal operating voltage level at the Point of Interconnection. In the event of such change in voltage level Interconnection Customer shall, at Interconnection Customer's sole expense, modify Interconnection Customer's Interconnection Facilities as necessary to accommodate the modified nominal operating voltage level. Interconnection Customer has been informed that initial use of a dual voltage Interconnection Customer may ameliorate the cost of accommodating a change in nominal operating voltage level.

Equipment Failure. Interconnection Customer acknowledges that it is responsible for repair or replacement of Interconnection Customer's primary transformer and for any and all other components of the Community Solar Project and the Interconnection Customer's Interconnection Facilities. Interconnection Customer is aware that its inability to timely repair or replace its transformer or any other component of the Community Solar Project or Interconnection Customer's Interconnection Facility could result in Interconnection Customer's inability to comply with its responsibilities under this Interconnection Agreement and could lead to disconnection of the Community Solar Project from the Public Utility's Distribution System and/or termination of this Interconnection Agreement pursuant to the terms of this Interconnection Agreement. Interconnection Customer acknowledges that the risk of this result is born solely by Interconnection Customer and may be substantially ameliorated by Interconnection Customer's elective maintenance of adequate reserve or spare components including but not limited to the Interconnection Customer's primary transformer.

Operation and Maintenance of Facilities Not Owned by the Public Utility. Interconnection Customer shall maintain, test, repair, keep accounts current on, or provide for the proper operation of any and all interconnection facilities, including but not limited to telemetry and communication equipment, not owned by the Public Utility.

Metering and Telemetry Communications Equipment. Notwithstanding any language of the CSP Interconnection Procedures, Public Utility shall not require Interconnection Customer to install a redundant or back-up meter or other telemetry communications equipment. However, Public Utility reserves the right to request that the Oregon Public Utility Commission authorize Public Utility to require Interconnection Customer to be responsible for all reasonable costs associated with redundant metering and communications equipment installed at the Community Solar Project, upon a determination by Public Utility that such equipment is necessary to maintain compliance with the mandatory reliability standards enforced by the North American Electric Reliability Corporation and the Western Electricity Coordinating Council.

Property Requirements. Interconnection Customer is required to obtain for the benefit of Public Utility at Interconnection Customer's sole cost and expense all real property rights, including but not limited to fee ownership, easements and/or rights of way, as applicable, for Public Utility owned Facilities using Public Utility's standard forms. Public Utility shall not be obligated to accept any such real property right that does not, at Public Utility's sole discretion, confer sufficient rights to access, operate, construct, modify, maintain, place and remove Public Utility owned facilities or is otherwise not conveyed using Public Utility's standard forms. Further, all real property on which Public Utility's Facilities are to be located must be environmentally, physically and operationally acceptable to the Public Utility at its sole discretion. Interconnection Customer is responsible for obtaining all permits required by all relevant jurisdictions for the project, including but not limited to, conditional use permits and construction permits; provided





## Interconnection Agreement for a Community Solar Project

however, Public Utility shall obtain, at Interconnection Customer's cost and schedule risk, the permits necessary to construct Public Utility's Facilities that are to be located on real property currently owned or held in fee or right by Public Utility. Except as expressly waived in writing by an authorized officer of Public Utility, all of the foregoing permits and real property rights (conferring rights on real property that is environmentally, physically and operationally acceptable to Public Utility) shall be acquired as provided herein as a condition to Public Utility's contractual obligation to construct or take possession of facilities to be owned by the Public Utility under this Agreement. Public Utility shall have no liability for any project delays or cost overruns caused by delays in acquiring any of the foregoing permits and/or real property rights, whether such delay results from the failure to obtain such permits or rights or the failure of such permits or rights to meet the requirements set forth herein. Further, any completion dates, if any, set forth herein with regard to Public Utility's obligations shall be equitably extended based on the length and impact of any such delays.

Relay and Control Settings. Interconnection Customer must allow the Public Utility to hold all Level 2 relay passwords for any control and/or protective device within their control at the Point of Interconnection and/or Community Solar Project which directly impacts the Public Utility's electrical system. Level 2 passwords are those which allow actual modifications to control and/or relay settings. This will ensure the Public Utility is aware of and approves any changes being made by the Interconnection Customer. Furthermore; this will ensure there are no negative impacts to the Public Utility's Electrical System or other existing customers. Should the Interconnection Customer require modification to the settings associated with control/protective devices connected to the Electrical System the Interconnection Customer will contact the Public Utility and provide in writing the justification and/or need for the proposed modification(s). This will allow the Public Utility time to analyze and ensure there are no negative impacts to the associated connected systems and customers. Any modifications of control and/or relay settings without review and acknowledgement of acceptance by Public Utility will be considered a breach of Interconnect Agreement and will lead to disconnection from the Public Utility's system.



## Interconnection Agreement for a Community Solar Project

### Attachment 5

#### Public Utility' s Description of its Upgrades and Best Estimate of Upgrade Costs

**Distribution Upgrades:** Install communications for transfer-trip at line recloser. Estimated cost is \$62,000.

**System Upgrades:** The following locations will require the System Upgrades described below:

- Install communications for transfer trip at Cabbage Hill communications site. Estimated cost is \$20,000
- Install new VT, relaying, and communications equipment for transfer trip at McKay substation. Estimated cost is \$119,000
- Install communications equipment at Buckaroo substation. Estimated cost is \$5,000.

Contingent Facilities. As identified in the Facilities Study for this project dated October 28, 2020 the following upgrades are required to be in-service prior to this project:

Higher priority interconnection request Q1045 requires Bonneville Power Administration (“BPA”) to update settings to relays in its Roundup substation to accommodate reverse power flow. The setting updates are assumed to be complete prior to the commencement of generation activities of the Applicant’s generating facility. If the Applicant chooses to proceed prior to Q1045 the Public Utility will coordinate with BPA to determine if the settings updates must be assigned to the Applicant’s interconnection request.



## Interconnection Agreement for a Community Solar Project

### Attachment 6

#### Scope of Work

##### COMMUNITY SOLAR PROJECT MODIFICATIONS

The following outlines the design, procurement, construction, installation, and ownership of equipment at the Applicant's Community Solar Project.

##### APPLICANT TO BE RESPONSIBLE FOR

- Design the Community Solar Project with reactive power capabilities necessary to operate within the full power factor range of 0.95 leading to 0.95 lagging as measured at the Point of Interconnection. The reactive compensation must be designed such that the discreet switching of all reactive devices (if required by the Applicant) does not cause step voltage changes greater than +/-3% on the Public Utility's system.
- Equip the Community Solar Project generators capable of operating under voltage reactive power mode, active power reactive power mode, and constant reactive power mode as per IEEE standard 1547. This project shall be capable of activating each of these modes one at a time. The Public Utility reserves the right to specify any mode and settings within the limits of IEEE standard 1547 needed before or after the Community Solar Project enters service. The Applicant shall be responsible for implementing settings modifications and mode selections as requested by the Public Utility within an acceptable timeframe.
- Operate the Community Solar Project under constant power factor mode with a unity power factor setting unless specifically requested otherwise by the Public Utility. The Community Solar Project is expressly forbidden from actively participating in voltage regulation of the Public Utilities system without written request or authorization from the Public Utility.
- Operate the Community Solar Project so minimum power quality requirements in PacifiCorp's Engineering Handbook section 1C are met, the standards are available at <https://www.pacificpower.net/about/power-quality-standards.html>. Requirements specified in the System Impact Study that exceed requirements in the Engineering Handbook section 1C power quality standards shall apply.
- Procure and install a step up transformer that will hold the phase to neutral voltages within limits when the generating facility is isolated with the Public Utility's local system until the generation disconnects.
- Design, procure, install, and own a Public Utility approved 12.5 kV recloser containing a Schweitzer Engineering Laboratories ("SEL") 651R or 351R relay/controller to monitor the voltage and frequency of the Generating Facility, to detect faults and to monitor current flow.
- Procure and install either voltage or potential instrument transformers on the Public Utility side of the recloser to support transfer trip.
- Input the settings provided by the Public Utility into the recloser relay. Applicant may enhance and add to the relay settings as long as the functional requirements established by the Public Utility are not altered.
- Provide the Public Utility Level 2 password control of the recloser relay following programming and commissioning.

## **Interconnection Agreement for a Community Solar Project**

- If deemed necessary provide the Public Utility an easement, approved by the Public Utility, to allow the Public Utility to construct a radio system to develop a link with the Public Utility's Cabbage Hill communications site. The communications equipment will be installed in an enclosure. The Applicant shall provide the Public Utility unencumbered access to its communications enclosure.
- Terminate the control cable required for implementing the direct transfer trip scheme, provided by the Public Utility at the recloser relay.
- Provide Public Utility unfettered and maintained access to its interconnection facilities.
- Construct the Applicant's last pole and span of conductor tying to the Public Utility's interconnection facilities to the Public Utility's standard and leave sufficient conductor for the Public Utility to terminate it on the first Public Utility structure.
- Arrange for and provide permanent retail service for power that will flow from the Public Utility's system when the Project is not generating. This arrangement must be in place prior to approval for backfeed.
- Provide any construction or backup retail service necessary for the Project.
- Provide the Public Utility a Professional Engineer ("PE") stamped maintenance plan for all Applicant facilities.

### **PUBLIC UTILITY TO BE RESPONSIBLE FOR**

- Develop and provide the settings for Applicant's recloser relay.
- Observe and provide acceptance of the relay settings in the Applicant recloser relay.
- Observe and provide acceptance of the Applicant's design of the final span of conductor and pole.
- Terminate the Applicant's final span of conductor onto the Public Utility owned interconnection facilities.
- Procure and install radio system and associated communications equipment within an enclosure to develop a radio link to the Cabbage Hill communications site.
- Provide the Applicant sufficient control cable for Applicant to terminate to its recloser relay. Observe the installation and confirm connectivity and functionality of the transfer trip communications path.
- Identify any necessary studies that the Applicant must have performed.

### **POINT OF INTERCONNECTION**

The following outlines the design, procurement, construction, installation, and ownership of equipment at the POI.

### **APPLICANT TO BE RESPONSIBLE FOR**

- Procure, on behalf of the Public Utility, any necessary permits and/or property rights for the Public Utility's line extension facilities. All property rights shall be in the name of the Public Utility and terms approved by the Public Utility.
- Procure, on behalf of the Public Utility, the equipment for the Public Utility's line extension facilities as specified by the Public Utility.

## **Interconnection Agreement for a Community Solar Project**

- Construct, per Public Utility standards, the Public Utility line extension facilities including the poles, conductor, cutouts, fuses, jumpers and a gang operated switch. The Public Utility will make the final terminations to the Public Utility's existing distribution facilities.
- Comply with all applicable portions of the Public Utility's applicant-built line extension policy.
- Provide unfettered access to the Public Utility at any time construction of the Public Utility line extension is occurring in order for the Public Utility to inspect.
- Promptly remedy any deficiencies that the Public Utility identifies with procured equipment or construction of the Public Utility line extension.
- Indemnify the Public Utility for claims arising from Applicant's construction of the Public Utility's line extension under the terms and procedures applicable to Article 5.2.
- Transfer control and ownership of the Public Utility's line extension facilities following acceptance of the construction by the Public Utility.
- Provide as-built drawings of the Public Utility's line extension facilities.

### **PUBLIC UTILITY TO BE RESPONSIBLE FOR**

- Design, own and maintain at the Applicant's expense the required extension of the 12.5 kV facilities from Public Utility's existing facilities to the Point of Change of Ownership including a minimum of two poles, conductor, cutouts, fuses, jumpers and a gang operated switch.
- Provide the Applicant with the design specifications for the Public Utility's line extension facilities.
- Observe the Applicant's construction of the Public Utility's line extension facilities and provided acceptance of conformance with Public Utility standards upon completion or notify the Applicant of any deficiencies that must be remedied.
- Terminate the final span of conductor from the Applicant built line extension to the Public Utility's existing distribution facilities.
- Design, procure and install 12.5 kV pole mounted revenue metering equipment for the Project including a revenue quality meter and instrument transformers.
- Provide and install a cellular connection for retail sales and generation accounting via the MV-90 translation system.

### **OTHER**

The following outlines the design, procurement, construction, installation, and ownership of equipment past the POI.

### **PUBLIC UTILITY TO BE RESPONSIBLE FOR**

- Distribution Circuit
  - Develop and implement a transfer trip scheme to trip the Applicant's generating facility offline for faults on the distribution line.
  - Install a radio system and associated communications equipment within an enclosure at line recloser UMDB1 to develop a link with the Public Utility's Cabbage Hill communications site.
  - Install a dead line checking control circuit at line recloser UMDB1.
- McKay Substation



## **Interconnection Agreement for a Community Solar Project**

- Procure and install a three phase, 15 kV padmount instrument voltage transformer on the line side of circuit breaker 5W857.
- Install a dead line checking control circuit.
- Update communications as necessary to support the transfer trip scheme.
- Buckaroo Substation
  - Procure and install communications equipment to effectuate the new transfer trip communications path.
- Cabbage Hill Communications Site
  - Procure and install communications equipment to effectuate the new transfer trip communications paths between the Applicant's recloser site and the line recloser UMDB1.



**Interconnection Agreement for a Community Solar Project**

**Attachment 7**

**Facility Connection (Interconnection) Requirements for Distribution Systems (34.5 kV and below)  
(attached)**

## AGREEMENT TO AMEND INTERCONNECTION AGREEMENT FOR A COMMUNITY SOLAR PROJECT

This **Agreement To Amend Interconnection Agreement for a Community Solar Project** (“Agreement”) is made and entered into this 15th day of August, 2022, by and between PacifiCorp, an Oregon corporation (the “Public Utility”) and Tutuilla Solar, LLC, an Oregon limited liability company (the “Interconnection Customer” or “Applicant”). Public Utility and Interconnection Customer may be referred to as a “Party” or collectively as the “Parties.”

### RECITALS

**WHEREAS**, Public Utility and Interconnection Customer have entered into an Interconnection Agreement for a Community Solar Project (“Interconnection Agreement”), dated December 28, 2021;

**WHEREAS**, Public Utility and Interconnection Customer have mutually agreed to amend one or more articles to the Interconnection Agreement; and

**WHEREAS**, consistent with Article 5.1 of the Interconnection Agreement, by notice to Public Utility on July 14, 2022, Sunthurst Energy, LLC assigned and transferred the Interconnection Agreement to Tutuilla Solar, LLC;

**WHEREAS**, Article 8.2 of the Interconnection Agreement states that the Parties may mutually agree to amend this Interconnection Agreement by a written instrument duly executed by both parties;

**NOW, THEREFORE**, in consideration of and subject to the mutual covenants contained herein, it is agreed:

- 1.0 The Parties acknowledge and mutually agree that the following attached article and attachment will substitute in its entirety the same article and attachment in the Interconnection Agreement:
  - Article 9
  - Attachment 3
- 2.0 Service under the Interconnection Agreement with the amended article and attachment will commence only upon execution by both Parties.
- 3.0 The Interconnection Agreement, with the attached substitute attachments shall constitute the entire agreement between the Parties.
- 4.0 All other provisions of the Interconnection Agreement will continue to apply.



**IN WITNESS WHEREOF**, the Parties have executed this Agreement in duplicate originals, each of which shall constitute and be an original effective Agreement between the Parties.

**PacifiCorp**

**By:** Rick Vai Digitally signed by  
Rick Vai  
Date: 2022.08.15  
21:40:56 -07'00'

**Title:** VP, Transmission

**Date:** 08/15/2022

**Tutuilla Solar, LLC**

**By:** D Hale

**Title:** Manager

**Date:** 8/12/2022



## Interconnection Agreement for a Community Solar Project

This Interconnection Agreement for a Community Solar Project (“Agreement”) is made and entered into this \_\_\_ day of \_\_\_\_\_ by and between Tutuilla Solar, LLC, a limited liability company organized and existing under the laws of the State of Oregon, (“Interconnection Customer” or “Applicant”) and PacifiCorp, a corporation, existing under the laws of the State of Oregon, (“Public Utility”). The Interconnection Customer and Public Utility may be referred to hereinafter singly as a “Party” or collectively as the “Parties.”

### **Recitals:**

**Whereas**, the Interconnection Customer is proposing to develop a Community Solar Project, consistent with the Application completed on April 29, 2020;

**Whereas**, the Interconnection Customer desires to interconnect the Community Solar Project with Public Utility’s Distribution System (“Distribution System”) in the State of Oregon; and

**Whereas**, the interconnection of the Community Solar Project and the Public Utility’s Distribution System is subject to the jurisdiction of the Public Utility Commission of Oregon (“Commission”) and are governed by OPUC Rule OAR 860, Division 088 (the “Rule”) and Public Utility’s Community Solar Interconnection Procedures (“CSP Interconnection Procedures”)

**Now, therefore**, in consideration of and subject to the mutual covenants contained herein, the Parties agree as follows:

### **Article 1.      Scope and Limitations of Agreement**

#### **1.1      Scope**

This Agreement establishes the standard terms and conditions under which the Community Solar Project with a Nameplate Capacity of no more than 3 megawatts (“MW”) will interconnect to, and operate in Parallel with, the Public Utility’s Distribution System. The Commission has approved standard terms and conditions governing this class of interconnection. Any additions, deletions or changes to the standard terms and conditions of interconnection as mutually agreed to by the Parties must be approved by the Commission. Terms with initial capitalization, when used in this Agreement, shall have the meanings given in the CSP Interconnection Procedures. This Agreement shall be construed where possible to be consistent with the Rule and the CSP Interconnection Procedures; to the extent this Agreement conflicts with the Rule or the CSP Interconnection Procedures, the Rule or CSP Interconnection Procedures shall take precedence.

#### **1.2      Definitions**

Unless defined in this Agreement, when used in this Agreement, with initial capitalization, the terms specified shall have the meanings given in CSP Interconnection Procedures.

#### **1.3      No Agreement Regarding Power Purchase, Transmission, or Delivery**

This Agreement does not constitute an agreement to purchase, transmit, or deliver any power



## Interconnection Agreement for a Community Solar Project

as if no subcontract had been made. Any applicable obligation imposed by this Agreement upon the hiring Party shall be equally binding upon, and will be construed as having application to, any subcontractor of such Party.

8.9.2 The obligations under this Article 8.9 will not be limited in any way by any limitation of subcontractor's insurance.

### 8.10 Reservation of Rights

Either Party will have the right to make a unilateral filing with the Commission to modify this Agreement. This reservation of rights provision will include but is not limited to modifications with respect to any rates terms and conditions, charges, classification of service, rule or regulation under CSP Interconnection Procedures rates or any applicable State or Federal law or regulation. Each Party shall have the right to protest any such filing and to participate fully in any proceeding before the Commission in which such modifications may be considered.

## Article 9. Notices and Records

### 9.1 General

Unless otherwise provided in this Agreement, any written notice, demand, or request required or authorized in connection with this Agreement shall be deemed properly given if delivered in person, delivered by recognized national courier service, or sent by first class mail, postage prepaid, to the person specified below:

### 9.2 Records

The Public Utility will maintain a record of all Interconnection Agreements and related Form attachments for as long as the interconnection is in place as required by the CSP Interconnection Procedures. The Public Utility will provide a copy of these records to the Interconnection Customer within 15 Business Days if a request is made in writing.

#### **If to the Interconnection Customer:**

Interconnection Customer: Tutuilla Solar, LLC

Attention: Daniel Hale

Address: P.O. Box 549

City: Stanfield State: Oregon Zip: 97875

Phone: 323-480-3835 Fax: 323-782-0760 E-mail: daniel@tutuillasolar.com

#### **If to Public Utility:**

Public Utility: PacifiCorp

Attention: Transmission Services

Address: 825 N.E. Multnomah Street, Suite 550

City: Portland State: OR Zip: 97232

Phone: 503-813-6077 Fax: 503-813-6873



## Interconnection Agreement for a Community Solar Project

### 9.3 Billing and Payment

Billings and payments shall be sent to the addresses set out below: (complete if different than article 9.2 above)

**If to the Interconnection Customer**

Same as 9.2

**If to Public Utility**

Public Utility: PacifiCorp Transmission

Attention: Central Cashiers Office

Address: 825 N.E. Multnomah Street, Suite 550

City: Portland State: OR Zip: 97232

### 9.4 Designated Operating Representative

The Parties will designate operating representatives to conduct the communications which may be necessary or convenient for the administration of the operations provisions of this Agreement. This person will also serve as the point of contact with respect to operations and maintenance of the Party's facilities (complete if different than article 9.2 above)

**Interconnection Customer's Operating Representative:**

Same as 9.2

**Public Utility's Operating Representative:** PacifiCorp

Attention: Grid Operations

Address: 9915 S.E. Ankeny Street

City: Portland State: OR Zip: 97216

Phone: 503-251-5197 Fax: 503-251-5228

### 9.5 Changes to the Notice Information

Either Party may change this notice information by giving five Business Days written notice prior to the effective date of the change.



## Interconnection Agreement for a Community Solar Project

### Attachment 3

#### Milestones

Estimated In-Service Date: May 25, 2023

Critical milestones and responsibility as agreed to by the Parties:

	<b>Milestone/Date</b>	<b>Responsible Party</b>
(1)	<u>Execute Agreement and Provide First Pre-Payment</u> December 28, 2021	<u>Applicant</u>
(2)	<u>Retail Service Request Established</u> January 7, 2022	<u>Both</u>
*(3)	<u>Provide Initial Design Package</u> January 21, 2022	<u>Applicant</u>
(4)	<u>Commence Engineering and Procurement</u> August 1, 2022	<u>Public Utility</u>
(5)	<u>Property/Permits/RoW Procured</u> September 23, 2022	<u>Applicant</u>
*(6)	<u>Final Design Package Provided</u> October 3, 2022	<u>Applicant</u>
(7)	<u>Engineering Design Complete</u> November 11, 2022	<u>Public Utility</u>
(8)	<u>Begin Construction</u> February 6, 2023	<u>Public Utility</u>
(9)	<u>Provide Maintenance &amp; Commissioning Plans</u> April 7, 2023	<u>Applicant</u>
(10)	<u>Construction Complete</u> May 5, 2023	<u>Both Parties</u>
(11)	<u>Commissioning Activities Complete</u> May 19, 2023	<u>Public Utility</u>
(12)	<u>Commissioning Document Review Complete</u> May 22, 2023	<u>Public Utility</u>



## Interconnection Agreement for a Community Solar Project

- |      |   |                                 |
|------|---|---------------------------------|
| (13) | <u>Backfeed</u><br>May 22, 2023                                   | <u>Applicant</u>                |
| (14) | <u>Initial Synchronization/Generation Testing</u><br>May 24, 2023 | <u>Applicant</u>                |
| (15) | <u>Commercial Operations</u><br>May 25, 2023                      | <u>Interconnection Customer</u> |

Interconnection Customer is to request Backfeed, 1<sup>st</sup> Sync, and Commercial Operations in writing (email acceptable) prior to the above dates. Public Utility is to approve Interconnection Customer requests without unreasonable delay. The Interconnection Customer will be required to demonstrate the reactive capability of the Community Solar Project and the voltage control system prior to Commercial Operations.

\*Applicant initial design package shall include final generating facility location, inverter selection, basic protection package and collector system location. Applicant final design package shall include PE stamped issued for construction (“IFC”) drawings for generating facility and collector substation.

### Payment Schedule\*

If Interconnection Customer agrees to progress payments option under Article 4.6 of the Interconnection Agreement, there are two potential options for a payment schedule below (please select one). If Interconnection Customer elects progress payment option but an option below is not selected, the Levelized Option will be selected by default. Failure to comply with the selected payment schedule will result in contractual breach, work stoppage, and slip of the milestone schedule above on a day-for-day basis. Interconnection Customer will still be responsible for all costs of the project. Public Utility will conduct initial accounting for the project within thirty (30) days of granting Commercial Operations approval and will determine if a partial refund of project costs is acceptable.

Please select an option:	<input type="checkbox"/>	<input checked="" type="checkbox"/>
	<u>Levelized Option</u>	<u>Stepped Option</u>
<u>Funds due no later than</u> December 28, 2021 (or when Interconnection Agreement is executed)	\$10,000	\$10,000
January 1, 2022	\$70,750	\$15,000
March 30, 2022	\$70,750	\$25,000
December 1, 2022	\$70,750	\$160,000
March 1, 2023	\$70,750	\$83,000

\*Please see Attachments 5 and 6 for further information as estimated costs may change during detailed engineering.

## AGREEMENT TO AMEND INTERCONNECTION AGREEMENT FOR A COMMUNITY SOLAR PROJECT

This **Agreement To Amend Interconnection Agreement for a Community Solar Project** (“Agreement”) is made and entered into this 22nd day of May, 2023, by and between PacifiCorp, an Oregon corporation (the “Public Utility”) and Tutuilla Solar, LLC (OCS024), an Oregon limited liability company (the “Interconnection Customer” or “Applicant”). Public Utility and Interconnection Customer may be referred to as a “Party” or collectively as the “Parties.”

### RECITALS

**WHEREAS**, Public Utility and Interconnection Customer have entered into an Interconnection Agreement for a Community Solar Project (“Interconnection Agreement”), dated December 28, 2021, and amended on August 15, 2022;

**WHEREAS**, Public Utility and Interconnection Customer have mutually agreed to amend one or more attachments to the Interconnection Agreement; and

**WHEREAS**, Article 8.2 of the Interconnection Agreement states that the Parties may mutually agree to amend this Interconnection Agreement by a written instrument duly executed by both parties;

**NOW, THEREFORE**, in consideration of and subject to the mutual covenants contained herein, it is agreed:

- 1.0 The Parties acknowledge and mutually agree that the following attached attachment will substitute in its entirety the same attachment in the Interconnection Agreement:   
  - Attachment 3
- 2.0 Service under the Interconnection Agreement with the amended attachment will commence only upon execution by both Parties.
- 3.0 The Interconnection Agreement, with the attached substitute attachment shall constitute the entire agreement between the Parties.
- 4.0 All other provisions of the Interconnection Agreement will continue to apply.

**IN WITNESS WHEREOF**, the Parties have executed this Agreement in duplicate originals, each of which shall constitute and be an original effective Agreement between the Parties.

**PacifiCorp**  
**By:** Kristopher J Bremer  
Kristopher J  
Bremer  
2023.05.22  
19:08:06 -07'00'  
**Title:** Dir., Transmission Svcs  
**Date:** 05/22/2023

**Tutuilla Solar, LLC (OCS024)**  
**By:** D Hale  
**Title:** Managing Member  
**Date:** 5/8/23





## Interconnection Agreement for a Community Solar Project

### Attachment 3

#### Milestones

Estimated In-Service Date: September 30, 2025

Critical milestones and responsibility as agreed to by the Parties:

	<b>Milestone/Date</b>	<b>Responsible Party</b>
(1)	<u>Execute Agreement and Provide First Pre-Payment</u> December 28, 2021 - completed	<u>Applicant</u>
(2)	<u>Retail Service Request Established</u> January 15, 2024	<u>Both</u>
*(3)	<u>Provide Initial Design Package</u> January 15, 2024	<u>Applicant</u>
(4)	<u>Commence Engineering and Procurement</u> March 4, 2024	<u>Public Utility</u>
(5)	<u>Property/Permits/RoW Procured</u> May 6, 2024	<u>Applicant</u>
*(6)	<u>Final Design Package Provided</u> October 3, 2024	<u>Applicant</u>
(7)	<u>Engineering Design Complete</u> November 11, 2024	<u>Public Utility</u>
(8)	<u>Begin Construction</u> January 2, 2025	<u>Public Utility</u>
(9)	<u>Provide Maintenance &amp; Commissioning Plans</u> August 7, 2025	<u>Applicant</u>
(10)	<u>Construction Complete</u> September 5, 2025	<u>Both Parties</u>
(11)	<u>Commissioning Activities Complete</u> September 19, 2025	<u>Public Utility</u>
(12)	<u>Commissioning Document Review Complete</u> September 22, 2025	<u>Public Utility</u>



## Interconnection Agreement for a Community Solar Project

- |      |   |                                 |
|------|---|---------------------------------|
| (13) | <u>Backfeed</u><br>September 22, 2025                                   | <u>Applicant</u>                |
| (14) | <u>Initial Synchronization/Generation Testing</u><br>September 24, 2025 | <u>Applicant</u>                |
| (15) | <u>Commercial Operations</u><br>September 30, 2025                      | <u>Interconnection Customer</u> |

Interconnection Customer is to request Backfeed, 1<sup>st</sup> Sync, and Commercial Operations in writing (email acceptable) prior to the above dates. Public Utility is to approve Interconnection Customer requests without unreasonable delay. The Interconnection Customer will be required to demonstrate the reactive capability of the Community Solar Project and the voltage control system prior to Commercial Operations.

\*Applicant initial design package shall include final generating facility location, inverter selection, basic protection package and collector system location. Applicant final design package shall include PE stamped issued for construction (“IFC”) drawings for generating facility and collector substation.

### Payment Schedule\*

If Interconnection Customer agrees to progress payments option under Article 4.6 of the Interconnection Agreement, there are two potential options for a payment schedule below (please select one). If Interconnection Customer elects progress payment option but an option below is not selected, the Levelized Option will be selected by default. Failure to comply with the selected payment schedule will result in contractual breach, work stoppage, and slip of the milestone schedule above on a day-for-day basis. Interconnection Customer will still be responsible for all costs of the project. Public Utility will conduct initial accounting for the project within thirty (30) days of granting Commercial Operations approval and will determine if a partial refund of project costs is acceptable.

Please select an option:	<input type="checkbox"/>	<input type="checkbox"/>
<u>Funds due no later than</u> December 28, 2021 (or when Interconnection Agreement is executed)	<u>Levelized Option</u>	<u>Stepped Option</u>
January 1, 2022	\$10,000	\$10,000 - paid
March 30, 2022	\$70,750	\$15,000 – paid
January 2, 2024	\$70,750	\$25,000 - paid
July 2, 2024	\$70,750	\$160,000
		\$83,000

\*Please see Attachments 5 and 6 for further information as estimated costs may change during detailed engineering.



## Interconnection Agreement for a Community Solar Project

This Interconnection Agreement for a Community Solar Project (“Agreement”) is made and entered into this 30<sup>th</sup> day of September, 2022, by and between Buckaroo Solar 1, LLC, a limited liability company organized and existing under the laws of the State of Oregon, (“Interconnection Customer” or “Applicant”) and PacifiCorp, a corporation, existing under the laws of the State of Oregon, (“Public Utility”). The Interconnection Customer and Public Utility may be referred to hereinafter singly as a “Party” or collectively as the “Parties.”

### **Recitals:**

**Whereas**, the Interconnection Customer is proposing to develop a Community Solar Project, consistent with the Application completed on February 10, 2021;

**Whereas**, the Interconnection Customer desires to interconnect the Community Solar Project with Public Utility’s Distribution System (“Distribution System”) in the State of Oregon; and

**Whereas**, the interconnection of the Community Solar Project and the Public Utility’s Distribution System is subject to the jurisdiction of the Public Utility Commission of Oregon (“Commission”) and are governed by OPUC Rule OAR 860, Division 088 (the “Rule”) and Public Utility’s Community Solar Interconnection Procedures (“CSP Interconnection Procedures”)

**Now, therefore**, in consideration of and subject to the mutual covenants contained herein, the Parties agree as follows:

### **Article 1.      **Scope and Limitations of Agreement****

#### **1.1      **Scope****

This Agreement establishes the standard terms and conditions under which the Community Solar Project with a Nameplate Capacity of no more than 3 megawatts (“MW”) will interconnect to, and operate in Parallel with, the Public Utility’s Distribution System. The Commission has approved standard terms and conditions governing this class of interconnection. Any additions, deletions or changes to the standard terms and conditions of interconnection as mutually agreed to by the Parties must be approved by the Commission. Terms with initial capitalization, when used in this Agreement, shall have the meanings given in the CSP Interconnection Procedures. This Agreement shall be construed where possible to be consistent with the Rule and the CSP Interconnection Procedures; to the extent this Agreement conflicts with the Rule or the CSP Interconnection Procedures, the Rule or CSP Interconnection Procedures shall take precedence.

#### **1.2      **Definitions****

Unless defined in this Agreement, when used in this Agreement, with initial capitalization, the terms specified shall have the meanings given in CSP Interconnection Procedures.

#### **1.3      **No Agreement Regarding Power Purchase, Transmission, or Delivery****

This Agreement does not constitute an agreement to purchase, transmit, or deliver any power



## **Interconnection Agreement for a Community Solar Project**

or capacity from the interconnected Community Solar Project nor does it constitute an electric service agreement.

### **1.4 Other Agreements**

Nothing in this Agreement is intended to affect any other agreement between the Public Utility and the Interconnection Customer or any other interconnected entity. If the provisions of this Agreement conflict with the provisions of any other Public Utility tariff or the CSP Interconnection Procedures, the Public Utility tariff or CSP Interconnection Procedures, as applicable, shall control.

### **1.5 Responsibilities of the Parties**

- 1.5.1 The Parties shall perform all obligations of this Agreement in accordance with all applicable laws.
- 1.5.2 The Interconnection Customer will construct, own, operate, and maintain its Community Solar Project in accordance with this Agreement, IEEE Standard 1547 (2003 ed), IEEE Standard 1547.1 (2005 ed), the National Electrical Code (2005 ed) and applicable standards required by the Commission and this Agreement.
- 1.5.3 Each Party shall be responsible for the safe installation, maintenance, repair and condition of their respective lines and appurtenances on their respective sides of the Point of Interconnection. Each Party shall provide Interconnection Facilities that adequately protect the other Parties' facilities, personnel, and other persons from damage and injury. The allocation of responsibility for the design, installation, operation, maintenance and ownership of Interconnection Facilities is prescribed in the Rule and this Agreement and the attachments to this Agreement.

### **1.6 Parallel Operation and Maintenance Obligations**

Once the Community Solar Project has been authorized to commence Parallel Operation by execution of this Agreement and satisfaction of Article 2.1 of this Agreement, the Interconnection Customer will abide by all written provisions for operating and maintenance as required by this Agreement and any attachments to this Agreement as well as by the Rule and as detailed by the Public Utility in a certification form, "Operations Form", title "Interconnection Equipment As-Built Specifications, Initial Settings and Operating Requirements."

### **1.7 Metering & Monitoring**

The Interconnection Customer will be responsible for metering and monitoring as required by the CSP Interconnection Procedures and as may be detailed in any attachments to this Agreement.

### **1.8 Power Quality**

The Interconnection Customer will design its Community Solar Project to maintain a composite power delivery at continuous rated power output at the Point of Interconnection



## **Interconnection Agreement for a Community Solar Project**

that meets the requirements set forth in IEEE 1547. The Public Utility may, in some circumstances, also require the Interconnection Customer to follow voltage or VAR schedules used by similarly situated, comparable generators in the control area. Any special operating requirements will be detailed in Operations Form and completed by the Public Utility as required by the Rule. The Public Utility shall not impose additional requirements for voltage or reactive power support outside of what may be required to mitigate impacts caused by interconnection of the Community Solar Project to the Public Utility's system.

### **Article 2. Inspection, Testing, Authorization, and Right of Access**

#### **2.1 Equipment Testing and Inspection**

The Interconnection Customer will test and inspect its Community Solar Project and Interconnection Facilities prior to interconnection in accordance with IEEE 1547 Standards as provided for in the Rule. The Interconnection will not be final and the Community Solar Project shall not be authorized to operate in parallel with the Public Utility's Distribution System until the Witness Test and Certificate of Completion provisions in the Rule have been satisfied. The Interconnection Customer shall pay or reimburse the Public Utility for its costs to participate in the Witness Test. Operation of the Community Solar Project requires an effective Interconnection Agreement; electricity sales require a power purchase agreement.

To the extent that the Interconnection Customer decides to conduct interim testing of the Community Solar Project prior to the Witness Test, it may request that the Public Utility observe these tests. If the Public Utility agrees to send qualified personnel to observe any interim testing proposed by the Interconnection Customer, the Interconnection Customer shall pay or reimburse the Public Utility for its cost to participate in the interim testing. If the Interconnection Customer conducts interim testing and such testing is observed by the Public Utility and the results of such interim testing are deemed acceptable by the Public Utility (hereinafter a "Public Utility-approved interim test"), then the Interconnection Customer may request that such Public Utility-approved interim test be deleted from the final Witness Testing. If the Public Utility elects to repeat any Public Utility-approved interim test as part of the final Witness Test, the Public Utility will bare its own expenses associated with participation in the repeated Public Utility-approved interim test.

#### **2.2 Right of Access:**

As provided in the CSP Interconnection Procedures, the Public Utility will have access to the Interconnection Customer's premises for any reasonable purpose in connection with the Interconnection Application or any Interconnection Agreement that is entered in to pursuant to the Rule and CSP Interconnection Procedures or if necessary to meet the legal obligation to provide service to its customers. Access will be requested at reasonable hours and upon reasonable notice, or at any time without notice in the event of an emergency or hazardous condition.



## Interconnection Agreement for a Community Solar Project

### **Article 3. Effective Date, Term, Termination, and Disconnection**

#### **3.1 Effective Date**

The Agreement shall become effective upon execution by the Parties.

#### **3.2 Term of Agreement**

The Agreement will be effective on the Effective Date and will remain in effect for a period of twenty (20) years from the commercial operations date or the life of the power purchase agreement, whichever is shorter.

#### **3.3 Termination**

No termination will become effective until the Parties have complied with all provisions of the CSP Interconnection Procedures and this Agreement that apply to such termination.

3.3.1 The Interconnection Customer may terminate this Agreement at any time by giving the Public Utility twenty (20) Business Days written notice.

3.3.2 Either Party may terminate this Agreement after default pursuant to Article 5.6 of this Agreement.

3.3.3 The Commission may order termination of this Agreement.

3.3.4 Upon termination of this Agreement, the Community Solar Project will be disconnected from the Public Utility's Distribution System at the Interconnection Customer's expense. The termination of this Agreement will not relieve either Party of its liabilities and obligations, owed or continuing at the time of the termination.

3.3.5 The provisions of this Article 3.3 shall survive termination or expiration of this Agreement.

#### **3.4 Temporary Disconnection**

The Public Utility or Interconnection Customer may temporarily disconnect the Community Solar Project from the Public Utility's Distribution System for so long as reasonably necessary, as provided in the CSP Interconnection Procedures, in the event one or more of the following conditions or events occurs:

3.4.1 Under emergency conditions, the Public Utility or the Interconnection Customer may immediately suspend interconnection service and temporarily disconnect the Community Solar Project without advance notice to the other Party. The Public Utility shall notify the Interconnection Customer promptly when it becomes aware of an emergency condition that may reasonably be expected to affect the Community Solar Project operation. The Interconnection Customer will notify the Public Utility promptly when it becomes aware of an emergency condition that may reasonably be expected to affect the Public Utility's Distribution System. To the extent information is known, the notification shall describe the emergency condition, the extent of the



## Interconnection Agreement for a Community Solar Project

damage or deficiency, the expected effect on the operation of both Parties' facilities and operations, its anticipated duration, and the necessary corrective action.

- 3.4.2 For routine Maintenance, Parties will make reasonable efforts to provide five Business Days' notice prior to interruption caused by routine maintenance or construction and repair to the Community Solar Project or Public Utility's Distribution System and shall use reasonable efforts to coordinate such interruption.
- 3.4.3 The Public Utility shall use reasonable efforts to provide the Interconnection Customer with prior notice of forced outages of the Distribution System. If prior notice is not given, the Public Utility shall, upon request, provide the Interconnection Customer written documentation after the fact explaining the circumstances of the disconnection.
- 3.4.4 For disruption or deterioration of service, where the Public Utility determines that operation of the Community Solar Project will likely cause disruption or deterioration of service to other customers served from the same electric system, or if operating the Community Solar Project could cause damage to the Public Utility's Distribution System, the Public Utility may disconnect the Community Solar Project. The Public Utility will provide the Interconnection Customer upon request all supporting documentation used to reach the decision to disconnect. The Public Utility may disconnect the Community Solar Project if, after receipt of the notice, the Interconnection Customer fails to remedy the adverse operating effect within a reasonable time which shall be at least five Business Days from the date the Interconnection Customer receives the Public Utility's written notice supporting the decision to disconnect, unless emergency conditions exist, in which case the provisions of 3.4.1 of the agreement apply.

### **3.5 Restoration of interconnection:**

The Parties shall cooperate with each other to restore the Community Solar Project, Interconnection Facilities, and Public Utility's Distribution System to their normal operating state as soon as reasonably practicable following any disconnection pursuant to Article 3.4.

## **Article 4. Cost Responsibility and Billing:**

As provided in the CSP Interconnection Procedures, the Applicant is responsible for the cost of all facilities, equipment, modifications and upgrades needed to facilitate the interconnection of the Community Solar Project to the Public Utility's Distribution System.

### **4.1 Minor Distribution System Modifications:**

As provided in the CSP Interconnection Procedures addressing Tier 2 review, it may be necessary for the Parties to construct certain Minor Modifications to interconnect under Tier 2 review. The Public Utility has itemized any required Minor Modifications in the



## **Interconnection Agreement for a Community Solar Project**

attachments to this Agreement, including a good-faith estimate of the cost of such Minor Modifications and the time required to build and install such Minor Modifications. The Interconnection Customer agrees to pay the costs of such Minor Modifications.

### **4.2 Interconnection Facilities:**

The Public Utility has identified under the review procedures of a Tier 2 review or under a Tier 4 Facilities Study, the Interconnection Facilities necessary to safely interconnect the Community Solar Project with the Public Utility. The Public Utility has itemized the required Interconnection Facilities in the attachments to this Agreement, including a good-faith estimate of the cost of the facilities and the time required to build and install those facilities. The Applicant is responsible for the cost of the Interconnection Facilities.

### **4.3 Interconnection Equipment:**

The Applicant is responsible for all reasonable expenses, including overheads, associated with owning, operating, maintaining, repairing, and replacing its Interconnection Equipment.

### **4.4 System Upgrades:**

The Public Utility will design, procure, construct, install, and own any System Upgrades. The actual cost of the System Upgrades, including overheads, will be directly assigned to an Applicant. In such cases when there are multiple Community Solar Facilities on a single circuit of the Distribution System that are jointly studied, the Public Utility shall allocate the System Upgrade costs based on the proportional capacity of each Community Solar Project. The cost sharing will be detailed in the Attachments to this Agreement. If a Community Solar Project that has been jointly studied and allocated a share of system upgrade costs withdraws, the Company will reassess the System Upgrades needed to complete the interconnection(s) and reallocate the System Upgrade costs to the remaining Community Solar Project(s) using the same methodology.

### **4.5 Adverse System Impact:**

The Public Utility is responsible for identifying the possible Affected Systems and coordinating with those identified Affected Systems, to the extent reasonably practicable, to allow the Affected System owner an opportunity to identify Adverse System Impacts on its Affected System, and to identify what mitigation activities or upgrades may be required on the Public Utility's system or on the Affected System to address impacts on Affected Systems and accommodate a Community Solar Project. Such coordination with Affected System owners shall include inviting Affected System owners to scoping meetings between the Public Utility and the Applicant and providing the Affected System owner with study results and other information reasonably required and requested by the Affected System owner to allow the Affected System owner to assess impacts to its system and determine required mitigation, if any, for such impacts. The Parties acknowledge that the Public Utility cannot compel the participation of the Affected System owner and that the Public Utility is not itself responsible for identifying impacts or mitigation associated with an Affected System. The actual cost of any actions taken to address the Adverse System Impacts, including overheads, shall be directly assigned to the Interconnection Customer. The





## Interconnection Agreement for a Community Solar Project

Interconnection Customer may be entitled to financial compensation from other Public Utilities or other Interconnection Customers who, in the future, utilize the upgrades paid for by the Interconnection Customer, to the extent allowed or required by the Commission. Such compensation will only be available to the extent provided for in the separate rules or Commission order. If the Parties have actual knowledge of an Adverse System Impact on an Affected System, the Applicant shall not interconnect and operate its Community Solar Project in parallel with the Public Utility's system, and the Public Utility shall not authorize or allow the continued interconnection or parallel operation of the Community Solar Project, unless and until such Adverse System Impact has been addressed to the reasonable satisfaction of the Affected System owner.

### 4.6 Deposit and Billings:

The Applicant agrees to pay to the Public Utility a deposit toward the cost to construct and install any required Interconnection Facilities and/or System Upgrades. The amount of the deposit shall be (select one of the following):

The Parties have agreed to progress payments and final payment under the schedule of payments attached to this Agreement; the Applicant shall pay a deposit equal to the lesser of (a) 25 percent of the estimated cost of the Interconnection Facilities and System Upgrades, or (b) \$10,000 – the amount of the deposit shall be \$10,000.

or

The Parties have not agreed to progress payments, the Applicant shall pay 100% of estimated costs as detailed in the Attachments to this agreement prior to the commencement of work.

If the actual costs of Interconnection Facilities and/or System Upgrades are different than the deposit amounts and/or progress and final payments provided for above, then the Applicant shall pay the Public Utility any balance owing or the Public Utility shall refund any excess deposit or progress payment within 20 Business Days of the date actual costs are determined.

If the Applicant's request to interconnect was jointly studied by the Company and the Applicant withdrawals, then any deposits or payments made by the withdrawing Applicant will be applied as a bill credit to not-yet-invoiced study costs for other remaining CSP Applicants that were jointly studied. Any remaining deposits or payments after the bill credits have been issued will be returned to the withdrawing Applicant.

## **Article 5. Assignment, Liability, Indemnity, Force Majeure, Consequential Damages, and Default**

### 5.1 Assignment

The Interconnection Agreement may be assigned by either Party upon fifteen (15) Business Days prior written notice. Except as provided in Articles 5.1.1 and 5.1.2, said assignment



## Interconnection Agreement for a Community Solar Project

shall only be valid upon the prior written consent of the non-assigning Party, which consent shall not be unreasonably withheld.

- 5.1.1 Either Party may assign the Agreement without the consent of the other Party to any affiliate (which shall include a merger of the Party with another entity), of the assigning Party with an equal or greater credit rating and with the legal authority and operational ability to satisfy the obligations of the assigning Party under this Agreement;
- 5.1.2 The Interconnection Customer shall have the right to assign the Agreement, without the consent of the Public Utility, for collateral security purposes to aid in providing financing for the Community Solar Project. For Community Solar Project systems that are integrated into a building facility, the sale of the building or property will result in an automatic transfer of this agreement to the new owner who shall be responsible for complying with the terms and conditions of this Agreement.
- 5.1.3 Any attempted assignment that violates this Article is void and ineffective. Assignment shall not relieve a Party of its obligations, nor shall a Party's obligations be enlarged, in whole or in part, by reason thereof. An assignee is responsible for meeting the same obligations as the assigning Interconnection Customer.
- 5.1.4 Any assignment not specifically approved by the Project Manager or the Program Administrator shall similarly be declared void and ineffective.

### **5.2 Limitation of Liability and Consequential Damages**

A Party is liable for any loss, cost claim, injury, or expense including reasonable attorney's fees related to or arising from any act or omission in its performance of the provisions of this Agreement entered into pursuant to the Rule except as provided for in ORS 757.300(4)(c). Neither Party will seek redress from the other Party in an amount greater than the amount of direct damage actually incurred.

### **5.3 Indemnity**

- 5.3.1 Liability under this Article 5.3 is exempt from the general limitations on liability found in Article 5.2.
- 5.3.2 The Parties shall at all times indemnify, defend, and hold the other Party harmless from, any and all damages, losses, claims, including claims and actions relating to injury to or death of any person or damage to property, demand, suits, recoveries, costs and expenses, court costs, attorney fees, and all other obligations by or to third parties, arising out of or resulting from the other Party's action or failure to meet its obligations under this Agreement on behalf of the indemnifying party, except in cases of gross negligence or intentional wrongdoing by the indemnified person.

## **Interconnection Agreement for a Community Solar Project**

- 5.3.3 If an indemnified person is entitled to indemnification under this Article 5.3 as a result of a claim by a third party, and the indemnifying party fails, after notice and reasonable opportunity to proceed under this Article 5.3, to assume the defense of such a claim, such indemnified person may at the expense of the indemnifying Party contest, settle or consent to the entry of any judgment with respect to, or pay in full, such claim.
- 5.3.4 If an indemnifying party is obligated to indemnify and hold any indemnified person harmless under this Article 5.3, the amount owing to the indemnified person shall be the amount of such indemnified person's actual loss, net of any insurance or other recovery.
- 5.3.5 Promptly after receipt by an indemnified person of any claim or notice of the commencement of any action or administrative or legal proceeding or investigation as to which the indemnity provided for in this Article 5.3 may apply, the indemnified person shall notify the indemnifying party of such fact. Any failure of or delay in such notification shall not affect a Party's indemnification obligation unless such failure or delay is materially prejudicial to the indemnifying party.
- 5.3.6 The indemnifying party shall have the right to assume the defense thereof with counsel designated by such indemnifying party and reasonably satisfactory to the indemnified person. If the defendants in any such action include one or more indemnified persons and the indemnifying party and if the indemnified person reasonably concludes that there may be legal defenses available to it and/or other indemnified persons which are different from or additional to those available to the indemnifying party, the indemnified person shall have the right to select separate counsel to assert such legal defenses and to otherwise participate in the defense of such action on its own behalf. In such instances, the indemnifying party shall only be required to pay the fees and expenses of one additional attorney to represent an indemnified person or indemnified persons having such differing or additional legal defenses.
- 5.3.7 The indemnified person shall be entitled, at its expense, to participate in any such action, suit or proceeding, the defense of which has been assumed by the indemnifying party. Notwithstanding the foregoing, the indemnifying party (i) shall not be entitled to assume and control the defense of any such action, suit or proceedings if and to the extent that, in the opinion of the indemnified person and its counsel, such action, suit or proceeding involves the potential imposition of criminal liability on the indemnified person, or there exists a conflict or adversity of interest between the indemnified person and the indemnifying Party, in such event the indemnifying Party shall pay the reasonable expenses of the indemnified person, and (ii) shall not settle or consent to the entry of any judgment in any action, suit or proceeding without the consent of the indemnified person, which shall not be reasonably withheld, conditioned or delayed.

## **Interconnection Agreement for a Community Solar Project**

### **5.4 Consequential Damages**

Neither Party shall be liable to the other Party, under any provision of this Agreement, for any losses, damages, costs or expenses for any special, indirect, incidental, consequential, or punitive damages, including but not limited to loss of profit or revenue, loss of the use of equipment, cost of capital, cost of temporary equipment or services, whether based in whole or in part in contract, in tort, including negligence, strict liability, or any other theory of liability; provided, however, that damages for which a Party may be liable to the other Party under another agreement will not be considered to be special, indirect, incidental, or consequential damages hereunder.

### **5.5 Force Majeure**

5.5.1 As used in this Agreement, a Force Majeure Event shall mean “any act of God, labor disturbance, act of the public enemy, war, acts of terrorism, insurrection, riot, fire, storm or flood, explosion, breakage or accident to machinery or equipment through no direct, indirect, or contributory act of a Party, any order, regulation or restriction imposed by governmental, military or lawfully established civilian authorities, or any other cause beyond a Party’s control. A Force Majeure Event does not include an act of negligence or intentional wrongdoing.”

5.5.2 If a Force Majeure Event prevents a Party from fulfilling any obligations under this Agreement, the Party affected by the Force Majeure Event (Affected Party) shall promptly notify the other Party of the existence of the Force Majeure Event. The notification must specify in reasonable detail the circumstances of the Force Majeure Event, its expected duration, and the steps that the Affected Party is taking to mitigate the effects of the event on its performance, and if the initial notification was verbal, it should be promptly followed up with a written notification. The Affected Party shall keep the other Party informed on a continuing basis of developments relating to the Force Majeure Event. Until the Force Majeure Event ends the Affected Party will be entitled to suspend or modify its performance of obligations under this Agreement (other than the obligation to make payments) only to the extent that the effect of the Force Majeure Event cannot be reasonably mitigated. The Affected Party will use reasonable efforts to resume its performance as soon as possible. The Parties shall immediately report to the Commission should a Force Majeure Event prevent performance of an action required by the Rule that the Rule does not permit the Parties to mutually waive.

### **5.6 Default**

5.6.1 No default shall exist where such failure to discharge an obligation (other than the payment of money) is the result of a Force Majeure Event as defined in this Agreement, or the result of an act or omission of the other Party. Upon a breach, the non-breaching Party shall give written notice of such breach to the breaching Party. Except as provided in Article 5.6.2, the breaching Party shall have sixty (60) Calendar Days from receipt of the beach notice within which to cure such breach;



## Interconnection Agreement for a Community Solar Project

provided however, if such breach is not capable of cure within 60 Calendar Days, the breaching Party shall commence such cure within twenty (20) Calendar Days after notice and continuously and diligently complete such cure within six months from receipt of the breach notice; and, if cured within such time, the breach specified in such notice shall cease to exist.

- 5.6.2 If a breach is not cured as provided for in this Article 5.6, or if a breach is not capable of being cured within the period provided for herein, the non-breaching Party shall have the right to declare a default and terminate this Agreement by written notice at any time until cure occurs, and be relieved of any further obligation hereunder and, whether or not that Party terminates this Agreement, to recover from the breaching Party all amounts due hereunder, plus all other damages and remedies to which it is entitled at law or in equity. Alternatively, the non-breaching Party shall have the right to seek dispute resolution with the Commission in lieu of default. The provisions of this Article 5.6 will survive termination of the Agreement.

### **Article 6. Insurance**

- 6.1** The Public Utility may not require the Community Solar Project to maintain general liability insurance in relation to the interconnection of the Community Solar Project with an Electric Nameplate Capacity of 200 kW or less. With regard to the interconnection of a Community Solar Project, the Interconnection Customer shall, at its own expense, maintain in force throughout the period of this Agreement general liability insurance sufficient to protect any person (including the Public Utility) who may be affected by the Interconnection Customer's Community Solar Project and its operation and such insurance shall be sufficient to satisfy the Interconnection Customer's indemnification responsibilities under Article 5.3 of this Agreement.
- 6.2** Within ten (10) days following execution of this Agreement, and as soon as practicable after the end of each fiscal year or at the renewal of the insurance policy and in any event within ninety (90) days thereafter, the Interconnection Customer shall provide the Public Utility with certification of all insurance required in this Agreement, executed by each insurer or by an authorized representative of each insurer.
- 6.3** All insurance required by this Article 6 shall name the Public Utility, its parent, associated and Affiliate companies and their respective directors, officers, agents, servants and employees ("Other Party Group") as additional insured. All policies shall contain provisions whereby the insurers waive all rights of subrogation against the Other Party Group and provide thirty (30) Calendar Days advance written notice to the Other Party Group prior to anniversary date of cancellation or any material change in coverage or condition. The Interconnection Customer's insurance shall contain provisions that specify that the policies are primary and shall apply to such extent without consideration for other policies separately carried and shall state that each insured is provided coverage as though a separate policy had been issued to each, except the insurer's liability shall not be increased beyond the amount for which the insurer would have been liable had only one insured been covered. The



## **Interconnection Agreement for a Community Solar Project**

insurance policies, if written on a Claims First Made Basis, shall be maintained in full force and effect for two (2) years after termination of this Agreement, which coverage may be in the form of tail coverage or extended reporting period coverage if agreed by the Parties.

- 6.4** The Parties agree to report to each other in writing as soon as practical all accidents or occurrences resulting in injuries to any person, including death, and any property damage arising out of this Agreement.
- 6.5** The requirements contained herein as to insurance are not intended to and shall not in any manner, limit or qualify the liabilities and obligations assumed by the Parties under this Agreement.

### **Article 7. Dispute Resolution**

Parties will adhere to the dispute resolution provisions in the CSP Interconnection Procedures.

### **Article 8. Miscellaneous**

#### **8.1 Governing Law, Regulatory Authority, and Rules**

The validity, interpretation and enforcement of the Agreement and each of its provisions shall be governed by the laws of the State of Oregon, without regard to its conflicts of law principles. The Agreement is subject to all applicable laws. Each Party expressly reserves the right to seek changes in, appeal, or otherwise contest any laws, orders, or regulations of a governmental authority.

#### **8.2 Amendment**

The Parties may mutually agree to amend the Agreement by a written instrument duly executed by both Parties in accordance with provisions of the Rule and applicable Commission Orders and provisions of the laws of the State of Oregon.

#### **8.3 No Third-Party Beneficiaries**

The Agreement is not intended to and does not create rights, remedies, or benefits of any character whatsoever in favor of any persons, corporations, associations, or entities other than the Parties, and the obligations herein assumed are solely for the use and benefit of the Parties, their successors in interest and where permitted, their assigns.

#### **8.4 Waiver**

- 8.4.1** The failure of a Party to the Agreement to insist, on any occasion, upon strict performance of any provision of the Agreement will not be considered a waiver of any obligation, right, or duty of, or imposed upon, such Party.
- 8.4.2** The Parties may agree to mutually waive a section of this Agreement so long as prior Commission approval of the waiver is not required by the Rule.



## **Interconnection Agreement for a Community Solar Project**

8.4.3 Any waiver at any time by either Party of its rights with respect to the Agreement shall not be deemed a continuing waiver or a waiver with respect to any other failure to comply with any other obligation, right, duty of the Agreement. Any waiver of the Agreement shall, if requested, be provided in writing.

### **8.5 Entire Agreement**

This Agreement, including any supplementary Form attachments that may be necessary, constitutes the entire agreement between the Parties with reference to the subject matter hereof, and supersedes all prior and contemporaneous understandings or agreements, oral or written, between the Parties with respect to the subject matter of the Agreement. There are no other agreements, representations, warranties, or covenants that constitute any part of the consideration for, or any condition to, either Party's compliance with its obligations under this Agreement.

### **8.6 Multiple Counterparts**

This Agreement may be executed in two or more counterparts, each of which is deemed an original but all constitute one and the same instrument.

### **8.7 No Partnership**

This Agreement will not be interpreted or construed to create an association, joint venture, agency relationship, or partnership between the Parties or to impose any partnership obligation or partnership liability upon either Party. Neither Party shall have any right, power or authority to enter into any agreement or undertaking for, or act on behalf of, or to act as or be an agent or representative of, or to otherwise bind, the other Party.

### **8.8 Severability**

If any provision or portion of this Agreement shall for any reason be held or adjudged to be invalid or illegal or unenforceable by any court of competent jurisdiction or other governmental authority; (1) such portion or provision shall be deemed separate and independent; (2) the Parties shall negotiate in good faith to restore insofar as practicable the benefits to each Party that were affected by such ruling; and (3) the remainder of this Agreement shall remain in full force and effect.

### **8.9 Subcontractors**

Nothing in this Agreement shall prevent a Party from utilizing the services of any subcontractor, or designating a third party agent as one responsible for a specific obligation or act required in this Agreement (collectively subcontractors), as it deems appropriate to perform its obligations under this Agreement; provided, however, that each Party will require its subcontractors to comply with all applicable terms and conditions of this Agreement in providing such services and each Party will remain primarily liable to the other Party for the performance of such subcontractor.

8.9.1 The creation of any subcontract relationship shall not relieve the hiring Party of any of its obligations under this Agreement. The hiring Party shall be fully responsible to the other Party for the acts or omissions of any subcontractor the hiring Party hires



## Interconnection Agreement for a Community Solar Project

as if no subcontract had been made. Any applicable obligation imposed by this Agreement upon the hiring Party shall be equally binding upon, and will be construed as having application to, any subcontractor of such Party.

8.9.2 The obligations under this Article 8.9 will not be limited in any way by any limitation of subcontractor's insurance.

### 8.10 Reservation of Rights

Either Party will have the right to make a unilateral filing with the Commission to modify this Agreement. This reservation of rights provision will include but is not limited to modifications with respect to any rates terms and conditions, charges, classification of service, rule or regulation under CSP Interconnection Procedures rates or any applicable State or Federal law or regulation. Each Party shall have the right to protest any such filing and to participate fully in any proceeding before the Commission in which such modifications may be considered.

## Article 9. Notices and Records

### 9.1 General

Unless otherwise provided in this Agreement, any written notice, demand, or request required or authorized in connection with this Agreement shall be deemed properly given if delivered in person, delivered by recognized national courier service, or sent by first class mail, postage prepaid, to the person specified below:

### 9.2 Records

The Public Utility will maintain a record of all Interconnection Agreements and related Form attachments for as long as the interconnection is in place as required by the CSP Interconnection Procedures. The Public Utility will provide a copy of these records to the Interconnection Customer within 15 Business Days if a request is made in writing.

#### **If to the Interconnection Customer:**

Interconnection Customer: Buckaroo Solar 1, LLC  
Attention: Daniel Hale  
Address: PO Box 549  
City: Stanfield State: OR Zip: 97875  
Phone: 323-480-3835 E-mail: PM1@buckaroosolar.com

#### **If to Public Utility:**

Public Utility: PacifiCorp  
Attention: Transmission Services  
Address: 825 N.E. Multnomah Street, Suite 550





## Interconnection Agreement for a Community Solar Project

City: Portland State: OR Zip: 97232  
Phone: 503-813-6077 Fax: 503-813-6873

### 9.3 Billing and Payment

Billings and payments shall be sent to the addresses set out below: (complete if different than article 9.2 above)

#### If to the Interconnection Customer

Interconnection Customer: Buckaroo Solar 1, LLC  
Attention: Daniel Hale  
Address: PO Box 549  
City: Stanfield State: OR Zip: 97875  
Phone: 323-480-3835 E-mail: PM1@buckaroosolar.com

#### If to Public Utility

Public Utility: PacifiCorp Transmission  
Attention: Central Cashiers Office  
Address: 825 N.E. Multnomah Street, Suite 550  
City: Portland State: OR Zip: 97232

### 9.4 Designated Operating Representative

The Parties will designate operating representatives to conduct the communications which may be necessary or convenient for the administration of the operations provisions of this Agreement. This person will also serve as the point of contact with respect to operations and maintenance of the Party's facilities (complete if different than article 9.2 above)

#### Interconnection Customer's Operating Representative:

Interconnection Customer: Buckaroo Solar 1, LLC  
Attention: Daniel Hale  
Address: PO Box 549  
City: Stanfield State: OR Zip: 97875  
Phone: 323-480-3835 E-mail: PM1@buckaroosolar.com

#### Public Utility's Operating Representative: PacifiCorp

Attention: Grid Operations  
Address: 9915 S.E. Ankeny Street  
City: Portland State: OR Zip: 97216  
Phone: 503-251-5197 Fax: 503-251-5228



## Interconnection Agreement for a Community Solar Project

### 9.5 Changes to the Notice Information

Either Party may change this notice information by giving five Business Days written notice prior to the effective date of the change.

### Article 10. Signatures

**IN WITNESS WHEREOF**, the Parties have caused this Agreement to be executed by their respective duly authorized representatives.

#### For Public Utility:

Name: **Rick Vail** Digitally signed by Rick Vail  
Date: 2022.09.01 05:56:25 -07'00'

Rick Vail

Title: VP, Transmission

Date: 09/01/2022

#### For the Applicant/Interconnection Customer:

Name: D Hale

Daniel Hale

Title: Managing Member

Date: 8/25/2022



## Interconnection Agreement for a Community Solar Project

### Attachment 1

#### Description of Interconnection Facilities And Metering Equipment Operated or Maintained by the Public Utility

**Community Solar Project:** Forty (40) CHINT SCA60KTL 60 kW inverters connect to two (2) 1.5 MVA 480V – 12.47 kV transformers ( $Z=5.75\%$ ), on the transformers high-side is a 200 kVA grounding bank ( $Z=5.75\%$ ). Total requested output is 2.4 MW. See Attachment 2.

**Interconnection Customer Interconnection Facilities:** A relay controlled recloser and Public Utility accessible disconnect switch. . See Attachment 2.

**Public Utility's Interconnection Facilities:** Bi-directional metering, transfer trip equipment, disconnect switch, and associated poles/structures. See Attachment 2.

**Estimated Cost of Public Utility's Interconnection Facilities:** Estimated cost of Public Utility's Interconnection Facilities directly assigned to Interconnection Customer: \$251,000.

**Estimated Annual Operation and Maintenance Cost of Public Utility's Interconnection Facilities:** \$250.

Interconnection Customer shall be responsible for Public Utility's actual cost for maintenance of the Public Utility's Interconnection Facilities.

**Point of Interconnection:** The point where the Public Utility's Interconnection Facilities connect to the Public Utility's 12.47 kV distribution circuit 5W403 out of Pendleton substation. See Attachment 2.

**Point of Change of Ownership:** The point where the Interconnection Customer's Interconnection Facilities connect to the Public Utility's Interconnection Facilities. See Attachment 2.

# Interconnection Agreement for a Community Solar Project

## Attachment 2

### One-line Diagram Depicting the Generating Facility, Interconnection Facilities, and Metering Equipment

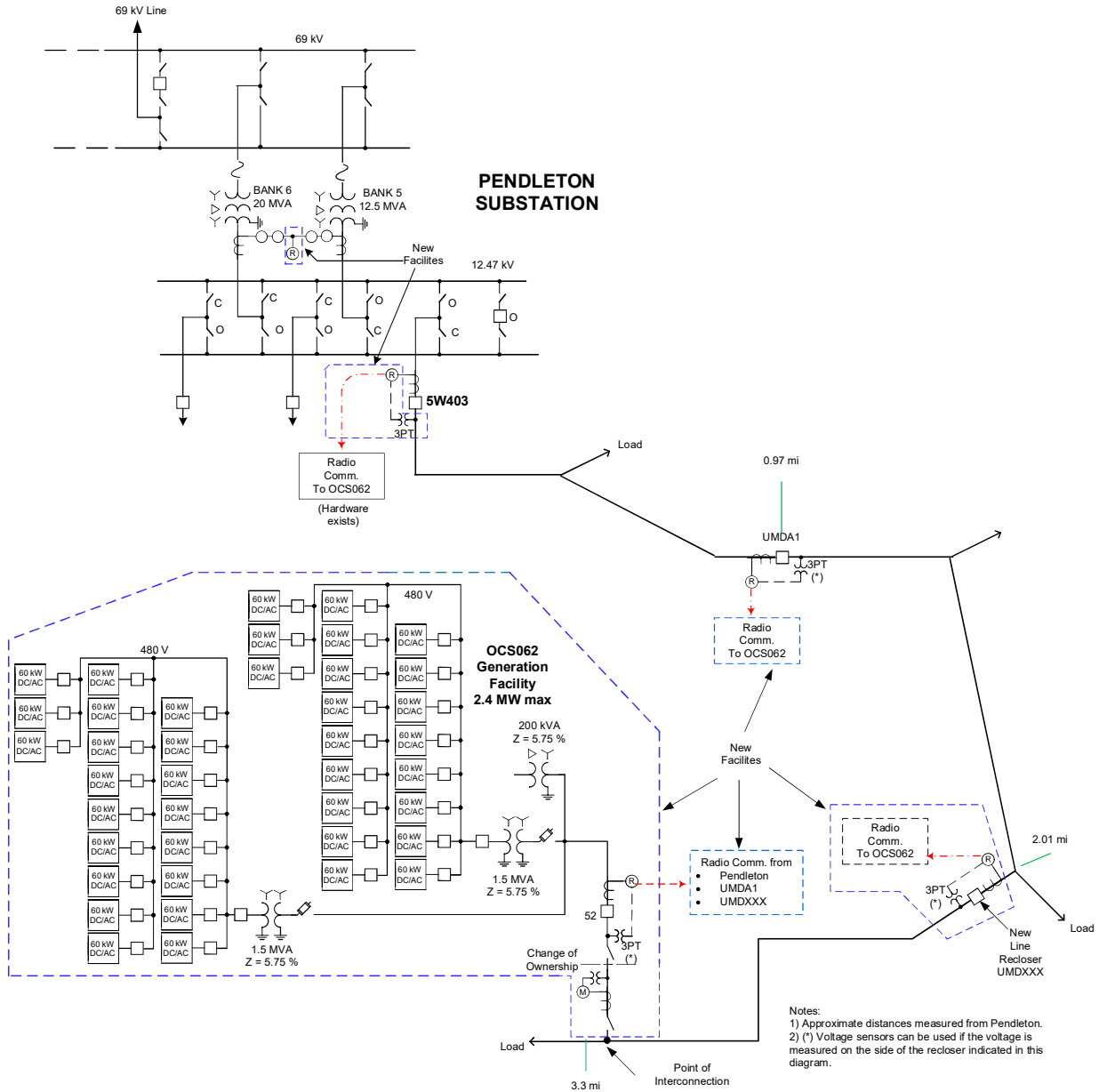



## Interconnection Agreement for a Community Solar Project

### Attachment 3

#### Milestones

Estimated In-Service Date: July 21, 2023

Critical milestones and responsibility as agreed to by the Parties:

<b>Milestone/Date</b>	<b>Responsible Party</b>
Execute Interconnection Agreement September 2, 2022	Applicant
Provision of First Progress Payment September 2, 2022	Applicant
Applicant and Public Utility Establish Retail Service Request September 16, 2022	Both Parties
*Applicant Initial Design Package Provided September 16, 2022	Applicant
Public Utility Engineering & Procurement Commences October 17, 2022	Public Utility
Applicant Property/Permits/ROW Procured October 31, 2022	Applicant
Public Utility Property/Permits/ROW Procured January 6, 2023	Public Utility
*Applicant Final Design Package Provided February 1, 2023	Applicant
Public Utility Engineering Design Complete June 9, 2023	Public Utility
Construction Begins July 24, 2023	Public Utility
Applicant Maintenance and Commissioning Plans Provided August 11, 2023	Applicant
Applicant and Public Utility Construction Complete	Both Parties



## Interconnection Agreement for a Community Solar Project

November 9, 2023

Public Utility Commissioning Activities Complete  
November 15, 2023 Public Utility

Public Utility Commissioning Document Review Complete  
November 21, 2023 Public Utility

Applicant’s Facilities Receive Backfeed Power  
November 22, 2023 Applicant

Initial Synchronization/Generation Testing  
November 28, 2023 Applicant

Commercial Operation  
November 30, 2023 Interconnection Customer

Interconnection Customer is to request Backfeed, 1<sup>st</sup> Sync, and Commercial Operations in writing (email acceptable) prior to the above dates. Public Utility is to approve Interconnection Customer requests without unreasonable delay. The Interconnection Customer will be required to demonstrate the reactive capability of the Community Solar Project and the voltage control system prior to Commercial Operations.

\* Any design modifications to the Interconnection Customer’s Community Solar Project after this date requiring updates to the Public Utility’s network model will result in a minimum of 3 months added to all future milestones including Commercial Operations.

### Payment Schedule\*

If Interconnection Customer agrees to progress payments option under Article 4.6 of the Interconnection Agreement, there are two potential options for a payment schedule below (please select one). If Interconnection Customer elects progress payment option but an option below is not selected, the Levelized Option will be selected by default. Failure to comply with the selected payment schedule will result in contractual breach, work stoppage, and slip of the milestone schedule above on a day-for-day basis. Interconnection Customer will still be responsible for all costs of the project. Public Utility will conduct initial accounting for the project within thirty (30) days of granting Commercial Operations approval and will determine if a partial refund of project costs is acceptable.

Please select an option:	<input type="checkbox"/>	<input checked="" type="checkbox"/>
<u>Funds due no later than</u> <u>September 2, 2022</u> (or when Interconnection Agreement is executed)	<u>Levelized Option</u> \$10,000	<u>Stepped Option</u> \$10,000



## Interconnection Agreement for a Community Solar Project

October 31, 2022	\$152,500	\$61,000
January 6, 2023	\$152,500	\$122,000
April 6, 2023	\$152,500	\$183,000
July 14, 2023	\$152,500	\$244,000

\*Please see Attachments 5 and 6 for further information as estimated costs may change during detailed engineering.



## Interconnection Agreement for a Community Solar Project

### Attachment 4

#### **Additional Operating Requirements for the Public Utility's Transmission System and/or Distribution System and Affected Systems Needed to Support the Interconnection Customer's Needs**

The interconnection of the Community Solar Project is subject to the rules contained within the CSP Interconnection Procedures. The interconnection of the Community Solar Project to the Public Utility's Distribution System shall be subject to, and the Interconnection Customer shall operate the Community Solar Project in accordance with, the Public Utility's policies governing interconnection of generation facilities to the Distribution System entitled "Facility Connection (Interconnection) Requirements for Distribution Systems (34.5 kV and below)" (or, "Policy 138") which policy document is available upon request from the Public Utility and is incorporated by this reference as part of the Interconnection Agreement between the Parties. In the event of a conflict between any aspect of this Attachment 4 (including without limitation the Public Utility's policies governing interconnection of generation facilities to the distribution system or the transmission system) and the rules contained in the CSP Interconnection Procedures, the rules shall prevail.

Parallel Operation. Interconnection Customer may operate the Community Solar Project in parallel with the Public Utility's Transmission System or Distribution System (collectively the "Electrical System"), but subject at all times to any operating instructions that the Public Utility's dispatch operators may issue and in accordance with all the provisions of this Interconnection Agreement and Good Utility Practice, and any other conditions imposed by the Public Utility in its sole discretion.

Community Solar Project Operation Shall Not Adversely Affect the Public Utility's Distribution System. Interconnection Customer shall operate the Community Solar Project in such a manner as not to adversely affect the Public Utility's Distribution System or any other element of the Public Utility's electrical system. Interconnection Customer's Community Solar Project shall deliver not more than the Design Capacity of 2.4 MW. Except as otherwise required by this Interconnection Agreement, Interconnection Customer shall operate the Community Solar Project in a manner compatible with the Public Utility's applicable voltage level and fluctuating voltage guidelines, titled "Facility Connection (Interconnection) Requirements for Distribution Systems (34.5 kV and below)", as it may be amended or superseded from time to time in the Public Utility's reasonable discretion, at the Point of Interconnection during all times that the Community Solar Project is connected and operating in parallel with the Public Utility's Distribution System. In its sole discretion, the Public Utility may specify rates of change in Interconnection Customer's deliveries to the Public Utility's Distribution System during any start-up of the Community Solar Project, in accordance with the above referenced policy.

Maximum Authorized Power Flow. The Community Solar Project shall not be operated in a manner that results in the flow of electric power onto the Public Utility's Distribution System during any fifteen (15) minute interval at levels in excess of 2400kVA from the Community Solar Project. If this provision is violated, the Public Utility may terminate this Interconnection Agreement or lock the Interconnection





## Interconnection Agreement for a Community Solar Project

Customer Disconnect Switch in the open position until such time as: (a) the Public Utility has studied the impact of additional generation on the Distribution System (at Interconnection Customer's cost and pursuant to a new study agreement between the Public Utility and Interconnection Customer) and the interconnection has been upgraded (at Interconnection Customer's cost and pursuant to a new or amended Facilities Construction Agreement and a new or amended Interconnection Agreement as deemed necessary by the Public Utility) in any manner necessary to accommodate the additional generation; or (b) the Interconnection Customer has modified the Community Solar Project or Interconnection Customer's Interconnection Facilities in such manner as to insure to the Public Utility's satisfaction that the Community Solar Project will no longer cause electric power to flow onto the Public Utility's Distribution System at a level in excess of 2400 kVA.

Harmonic Distortion or Voltage Flicker. Notwithstanding the study results, upon notice from the Public Utility that operation of the Community Solar Project is producing unacceptable harmonic distortions or voltage flicker on the Public Utility's Distribution System, Interconnection Customer shall at its sole cost remedy such harmonic distortions or voltage flicker within a reasonable time in accordance with Policy 138.

Reactive Power. Interconnection Customer shall at all times control the flow of reactive power between the Community Solar Project and the Public Utility's Distribution System within limits established in Policy 138. There shall be no obligation to pay for any Kvar or Kvar Hours flowing between Parties under terms of this agreement.

Islanding. If at any time during the term of this Interconnection Agreement the interconnection of the Community Solar Project to the Public Utility's Distribution System results in a risk of electrical islanding, or actual occurrences of electrical islanding, which the Public Utility reasonably concludes are incompatible with Good Utility Practice, the Parties shall (as necessary) study the issue and implement a solution that will eliminate or mitigate the risk of electrical islanding to a level deemed acceptable by the Public Utility. All costs associated with addressing any electrical islanding problems as required by this paragraph shall be paid by the Interconnection Customer, including without limitation any study costs, engineering costs, design costs, or costs to procure, install, operate and/or maintain required interconnection facilities or protective devices.

Voltage Regulation and Power Factor. The Interconnection Customer agrees to operate at unity power factor, but shall have the ability to operate at a 95% leading or lagging power factor in accordance with Policy 138. Prior to installation, Interconnection Customer shall provide the Public Utility with written notice of the device and/or operational constraints selected to satisfy this requirement and shall obtain the Public Utility's written approval of such device and/or operational constraints, which approval shall not be unreasonably withheld. In the event Interconnection Customer fails to operate the Community Solar Project within the voltage regulation constraints of Policy 138, the Public Utility may disconnect the Community Solar Project.



## Interconnection Agreement for a Community Solar Project

Modification of Nominal Operating Voltage Level. By providing Interconnection Customer with a one hundred and eighty (180) day notice, the Public Utility may at its sole discretion change the Public Utility's nominal operating voltage level at the Point of Interconnection. In the event of such change in voltage level Interconnection Customer shall, at Interconnection Customer's sole expense, modify Interconnection Customer's Interconnection Facilities as necessary to accommodate the modified nominal operating voltage level. Interconnection Customer has been informed that initial use of a dual voltage Interconnection Customer may ameliorate the cost of accommodating a change in nominal operating voltage level.

Equipment Failure. Interconnection Customer acknowledges that it is responsible for repair or replacement of Interconnection Customer's primary transformer and for any and all other components of the Community Solar Project and the Interconnection Customer's Interconnection Facilities. Interconnection Customer is aware that its inability to timely repair or replace its transformer or any other component of the Community Solar Project or Interconnection Customer's Interconnection Facility could result in Interconnection Customer's inability to comply with its responsibilities under this Interconnection Agreement and could lead to disconnection of the Community Solar Project from the Public Utility's Distribution System and/or termination of this Interconnection Agreement pursuant to the terms of this Interconnection Agreement. Interconnection Customer acknowledges that the risk of this result is born solely by Interconnection Customer and may be substantially ameliorated by Interconnection Customer's elective maintenance of adequate reserve or spare components including but not limited to the Interconnection Customer's primary transformer.

Operation and Maintenance of Facilities Not Owned by the Public Utility. Interconnection Customer shall maintain, test, repair, keep accounts current on, or provide for the proper operation of any and all interconnection facilities, including but not limited to telemetry and communication equipment, not owned by the Public Utility.

Metering and Telemetry Communications Equipment. Notwithstanding any language of the CSP Interconnection Procedures, Public Utility shall not require Interconnection Customer to install a redundant or back-up meter or other telemetry communications equipment. However, Public Utility reserves the right to request that the Oregon Public Utility Commission authorize Public Utility to require Interconnection Customer to be responsible for all reasonable costs associated with redundant metering and communications equipment installed at the Community Solar Project, upon a determination by Public Utility that such equipment is necessary to maintain compliance with the mandatory reliability standards enforced by the North American Electric Reliability Corporation and the Western Electricity Coordinating Council.

Property Requirements. Interconnection Customer is required to obtain for the benefit of Public Utility at Interconnection Customer's sole cost and expense all real property rights, including but not limited to fee ownership, easements and/or rights of way, as applicable, for Public Utility owned Facilities using Public Utility's standard forms. Public Utility shall not be obligated to accept any such real property right that does not, at Public Utility's sole discretion, confer sufficient rights to access, operate, construct, modify, maintain, place and remove Public Utility owned facilities or is otherwise not conveyed using Public



## Interconnection Agreement for a Community Solar Project

Utility's standard forms. Further, all real property on which Public Utility's Facilities are to be located must be environmentally, physically and operationally acceptable to the Public Utility at its sole discretion. Interconnection Customer is responsible for obtaining all permits required by all relevant jurisdictions for the project, including but not limited to, conditional use permits and construction permits; provided however, Public Utility shall obtain, at Interconnection Customer's cost and schedule risk, the permits necessary to construct Public Utility's Facilities that are to be located on real property currently owned or held in fee or right by Public Utility. Except as expressly waived in writing by an authorized officer of Public Utility, all of the foregoing permits and real property rights (conferring rights on real property that is environmentally, physically and operationally acceptable to Public Utility) shall be acquired as provided herein as a condition to Public Utility's contractual obligation to construct or take possession of facilities to be owned by the Public Utility under this Agreement. Public Utility shall have no liability for any project delays or cost overruns caused by delays in acquiring any of the foregoing permits and/or real property rights, whether such delay results from the failure to obtain such permits or rights or the failure of such permits or rights to meet the requirements set forth herein. Further, any completion dates, if any, set forth herein with regard to Public Utility's obligations shall be equitably extended based on the length and impact of any such delays.

Relay and Control Settings. Interconnection Customer must allow the Public Utility to hold all Level 2 relay passwords for any control and/or protective device within their control at the Point of Interconnection and/or Community Solar Project which directly impacts the Public Utility's electrical system. Level 2 passwords are those which allow actual modifications to control and/or relay settings. This will ensure the Public Utility is aware of and approves any changes being made by the Interconnection Customer. Furthermore; this will ensure there are no negative impacts to the Public Utility's Electrical System or other existing customers. Should the Interconnection Customer require modification to the settings associated with control/protective devices connected to the Electrical System the Interconnection Customer will contact the Public Utility and provide in writing the justification and/or need for the proposed modification(s). This will allow the Public Utility time to analyze and ensure there are no negative impacts to the associated connected systems and customers. The Public Utility shall review any such request, respond in writing with acceptance or, if denied, the reasons for said denial. If accepted, the Public Utility shall release to the Interconnection Customer the required password(s) so that the Interconnection Customer may affect the agreed-upon changes. The Interconnection Customer shall notify the Public Utility when the changes are placed into effect. Any modifications of control and/or relay settings without review and acknowledgement of acceptance by Public Utility will be considered a breach of Interconnect Agreement and will lead to disconnection from the Public Utility's system.



## Interconnection Agreement for a Community Solar Project

### Attachment 5

#### Public Utility' s Description of its Upgrades and Best Estimate of Upgrade Costs

**Distribution Upgrades:** Install new switch, modify existing switch, replace recloser, replace sectionalizer and install communications.

**System Upgrades:** The following locations will require the System Upgrades described below:

- Install voltage transformers at circuit breaker 5W403 and relays at Pendleton Substation.

Estimated Cost is \$369,000.



## Interconnection Agreement for a Community Solar Project

### Attachment 6

### Scope of Work

#### Community Solar Project Requirements

The following outlines the design, procurement, construction, installation, and ownership of equipment at the Applicant's Community Solar Project.

***APPLICANT TO BE RESPONSIBLE FOR***

- Design, construct, own and maintain the Applicant's generating facility and associated collector system.
- Operate the Community Solar Project under constant power factor mode with a unity power factor setting unless specifically requested otherwise by the Public Utility. The Community Solar Project is expressly forbidden from actively participating in voltage regulation of the Public Utilities system without written request or authorization from the Public Utility. The Community Solar Project shall have sufficient reactive capacity to enable the delivery of 100 percent of the plant output to the POI at unity power factor measured at 1.0 per unit voltage under steady state conditions.
- Operate the Community Solar Project so minimum power quality requirements in PacifiCorp's Engineering Handbook section 1C are met, the standards are available at <https://www.pacificpower.net/about/power-quality-standards.html>. Requirements specified in the System Impact Study that exceed requirements in the Engineering Handbook section 1C power quality standards shall apply.
- As per NERC standard VAR-001-1, the Public Utility is required to specify voltage or reactive power schedule at the Point of interconnection. Under normal conditions, the Public Utility's system should not supply reactive power to the Community Solar Project.
- Install a transformer that will hold the phase to neutral voltages within limits when the Community Solar Project is isolated with the Public Utility's local system until the generation disconnects.
- Design, procure, install, and own a Public Utility approved 12.47 kV recloser containing a Schweitzer Engineering Laboratories ("SEL") 651R relay/controller to perform the following functions:
  - Detect faults on the 12.47 kV equipment at the Community Solar Project
  - Detect faults on the 12.47 kV line to Pendleton substation
  - Monitor the unbalance current flowing through the grounding transformer and protect the transformer from damage due to phase unbalances on the 12.47 kV circuit
  - Monitor the voltage and react to under or over frequency, and /or magnitude of the voltage
  - Receive transfer trip from Pendleton substation, line recloser UMDA1, or line recloser UMDXXX. NOTE: Line recloser UMDXXX to be given final number designation upon installation.



## Interconnection Agreement for a Community Solar Project

- Procure and install instrument transformers or voltage sensors on the Public Utility side of the recloser.
- Input the settings provided by the Public Utility into the recloser relay.
- Provide the Public Utility Level 2 password control of the recloser relay.
- Terminate the control cable provided by the Public Utility in the recloser relay.
- Provide the Public Utility the necessary easement to allow the Public Utility to construct its line extension between its existing facilities and the Point of Change of Ownership.
- Provide Public Utility unfettered and maintained access to its interconnection facilities.
- Construct the Applicant's last pole at the Point of Change of Ownership to Public Utility's standard.
- Arrange for and provide permanent retail service for power that will flow from the Public Utility's system when the Project is not generating. Applicant shall coordinate with the Public Utility's customer service group establish a request number and account number.
- Provide any construction or backup retail service necessary for the Project.
- Provide the Public Utility a Professional Engineer ("PE") stamped maintenance plan for all Applicant protective equipment.

### ***PUBLIC UTILITY TO BE RESPONSIBLE FOR***

- Coordinate with the Applicant to establish request and account numbers.
- Develop and provide overcurrent, voltage and frequency settings for the Applicant's recloser relay.
- Observe and provide acceptance of the relay settings in the Applicant's recloser relay.
- Observe and provide acceptance of the installation of the Applicant's final pole at the point of change of ownership.
- Terminate the final span of conductor onto the Applicant's final pole.
- Provide the Applicant control cable for Applicant to terminate to its recloser relay. Observe the installation and confirm connectivity and functionality of the transfer trip communications path.

### **Point of Interconnection**

The following outlines the design, procurement, construction, installation, and ownership of equipment at the Point of Interconnection.

### ***PUBLIC UTILITY TO BE RESPONSIBLE FOR***

- Design, procure, install, own and maintain at the Applicant's expense the required extension of the 12.47 kV facilities from Public Utility's existing facilities near facility point ("FP") 01102032.0117000 to the point of change of ownership including a minimum of two poles, conductor, cutouts, fuses, jumpers and a gang operated switch.
- Install an approximately 50' wood pole and spread spectrum radio equipment. The radio will be designed to establish a link with the Public Utility's Cabbage Hill communications site.



## Interconnection Agreement for a Community Solar Project

- Provide the Interconnection Customer cable from its radio to the Interconnection Customer recloser.
- Design, procure and install 12.47 kV revenue metering equipment for the Project including a revenue quality meter and instrument transformers.
- Provide and install a cellular connection for retail sales and generation accounting via the MV-90 translation system.

### Other

The following outlines the design, procurement, construction, installation, and ownership of equipment past the Point of Interconnection.

#### ***PUBLIC UTILITY TO BE RESPONSIBLE FOR***

- Distribution Circuit
  - Procure and install a gang operated switch at FP 01102032.0116001 to establish a new open point between distribution circuits 5W403 and 5W856.
  - Modify the existing switch at FP 01102032.0124402 to normally closed.
  - Replace the existing recloser UMDA1 installed at FP 01102032.0119000 with a recloser containing an SEL 651R control.
  - Procure and install instrument transformers on the load side of recloser UMDA1.
  - Install an approximately 30' wood pole and spread spectrum radio equipment at line recloser UMDA1. The radio will be designed to establish a link with the Public Utility's Pendleton substation.
  - Replace the existing sectionalizers installed at FP 01102032.0124501 with a new line recloser referred to as UMDXXX.
  - Install an approximately 90' wood pole and spread spectrum radio equipment at line recloser UMDXXX. The radio will be designed to establish a link with the Public Utility's Cabbage Hill communications site.
  - Install deadline check control circuits at both line reclosers UMDA1 and UMDXXX.
  - Develop and implement transfer trip schemes to disconnect the Interconnection Customer's Community Solar Project for operation of either recloser UMDA1 or UMDXXX.
- Pendleton Substation
  - Procure and install three 12.5 kV voltage transformers on the low side of circuit breaker 5W403.
  - Replace the existing electromechanical relays for circuit breaker 5W403 with a multifunction digital relay.
  - Develop and implement a transfer trip scheme to disconnect the Interconnection Customer's Community Solar Project for the following:
    - Faults on the 12.47 kV circuit 5W403
    - Faults in the 69 – 12.47 kV transformers
    - Faults on the 69 kV bus



## **Interconnection Agreement for a Community Solar Project**

- Cabbage Hill Communications Site
  - Install antennas and supportive communications equipment to establish links with the radio systems installed at the POI recloser and line recloser UMDXXX.





**Interconnection Agreement for a Community Solar Project**

**Attachment 7**

**Facility Connection (Interconnection) Requirements for Distribution Systems (34.5 kV and below)  
(attached)**

## AGREEMENT TO AMEND INTERCONNECTION AGREEMENT FOR A COMMUNITY SOLAR PROJECT

This **Agreement To Amend Interconnection Agreement for a Community Solar Project** (“Agreement”) is made and entered into this 22nd day of May, 2023, by and between PacifiCorp, an Oregon corporation (the “Public Utility”) and Buckaroo Solar 1, LLC (OCS062), an Oregon limited liability company (the “Interconnection Customer” or “Applicant”). Public Utility and Interconnection Customer may be referred to as a “Party” or collectively as the “Parties.”

### RECITALS

**WHEREAS**, Public Utility and Interconnection Customer have entered into an Interconnection Agreement for a Community Solar Project (“Interconnection Agreement”), dated September 30, 2022, ;

**WHEREAS**, Public Utility and Interconnection Customer have mutually agreed to amend one or more attachments to the Interconnection Agreement; and

**WHEREAS**, Article 8.2 of the Interconnection Agreement states that the Parties may mutually agree to amend this Interconnection Agreement by a written instrument duly executed by both parties;

**NOW, THEREFORE**, in consideration of and subject to the mutual covenants contained herein, it is agreed:

- 1.0 The Parties acknowledge and mutually agree that the following attached attachment will substitute in its entirety the same attachment in the Interconnection Agreement:   
  - Attachment 3
- 2.0 Service under the Interconnection Agreement with the amended attachment will commence only upon execution by both Parties.
- 3.0 The Interconnection Agreement, with the attached substitute attachment shall constitute the entire agreement between the Parties.
- 4.0 All other provisions of the Interconnection Agreement will continue to apply.

**IN WITNESS WHEREOF**, the Parties have executed this Agreement in duplicate originals, each of which shall constitute and be an original effective Agreement between the Parties.

**PacifiCorp**

**By:** Kristopher J Bremer Kristopher J Bremer  
2023.05.22  
19:09:32 -07'00'

**Title:** Dir., Transmission Svcs

**Date:** 05/22/2023

**Buckaroo Solar 1, LLC (OCS062)**

**By:** D Hale

**Title:** Managing Member

**Date:** 5/8/23



## Interconnection Agreement for a Community Solar Project

### Attachment 3

#### Milestones

Estimated In-Service Date: September 30, 2025

Critical milestones and responsibility as agreed to by the Parties:

<b>Milestone/Date</b>	<b>Responsible Party</b>
<u>Execute Interconnection Agreement</u> September 2, 2022 - completed	<u>Applicant</u>
<u>Provision of First Progress Payment</u> September 2, 2022 - completed	<u>Applicant</u>
<u>Applicant and Public Utility Establish Retail Service Request</u> January 15, 2024	<u>Both</u>
<u>*Applicant Initial Design Package Provided</u> January 15, 2024	<u>Applicant</u>
<u>Public Utility Engineering &amp; Procurement Commences</u> March 4, 2024	<u>Public Utility</u>
<u>Applicant Property/Permits/ROW Procured</u> May 6, 2024	<u>Applicant</u>
<u>Public Utility Property/Permits/ROW Procured</u> October 2, 2024	<u>Public Utility</u>
<u>*Applicant Final Design Package Provided</u> October 3, 2024	<u>Applicant</u>
<u>Public Utility Engineering Design Complete</u> November 11, 2024	<u>Public Utility</u>
<u>Construction Begins</u> January 2, 2025	<u>Public Utility</u>
<u>Applicant Maintenance and Commissioning Plans Provided</u> August 7, 2025	<u>Applicant</u>
<u>Applicant and Public Utility Construction Complete</u>	<u>Both</u>



## Interconnection Agreement for a Community Solar Project

September 5, 2025

Public Utility Commissioning Activities Complete  
September 19, 2025

Public Utility

Public Utility Commissioning Document Review Complete  
September 21, 2025

Public Utility

Applicant’s Facilities Receive Backfeed Power  
September 22, 2025

Applicant

Initial Synchronization/Generation Testing  
September 24, 2025

Applicant

Commercial Operation  
September 30, 2025

Both

Interconnection Customer is to request Backfeed, 1<sup>st</sup> Sync, and Commercial Operations in writing (email acceptable) prior to the above dates. Public Utility is to approve Interconnection Customer requests without unreasonable delay. The Interconnection Customer will be required to demonstrate the reactive capability of the Community Solar Project and the voltage control system prior to Commercial Operations.

\* Any design modifications to the Interconnection Customer’s Community Solar Project after this date requiring updates to the Public Utility’s network model will result in a minimum of 3 months added to all future milestones including Commercial Operations.

### Payment Schedule\*

If Interconnection Customer agrees to progress payments option under Article 4.6 of the Interconnection Agreement, there are two potential options for a payment schedule below (please select one). If Interconnection Customer elects progress payment option but an option below is not selected, the Levelized Option will be selected by default. Failure to comply with the selected payment schedule will result in contractual breach, work stoppage, and slip of the milestone schedule above on a day-for-day basis. Interconnection Customer will still be responsible for all costs of the project. Public Utility will conduct initial accounting for the project within thirty (30) days of granting Commercial Operations approval and will determine if a partial refund of project costs is acceptable.

Please select an option:



Funds due no later than  
September 2, 2022

Levelized Option

Stepped Option

(or when Interconnection  
Agreement is executed)

\$10,000

\$10,000 - paid

January 2, 2024

\$152,500

\$61,000



## Interconnection Agreement for a Community Solar Project

July 2, 2024	\$152,500	\$122,000
September 2, 2024	\$152,500	\$183,000
December 2, 2024	\$152,500	\$244,000

\*Please see Attachments 5 and 6 for further information as estimated costs may change during detailed engineering.



## Interconnection Agreement for a Community Solar Project

This Interconnection Agreement for a Community Solar Project (“Agreement”) is made and entered into this 30th day of [September, 2022](#), by and between Buckaroo Solar 2, LLC, a limited liability company organized and existing under the laws of the State of Oregon, (“Interconnection Customer” or “Applicant”) and PacifiCorp, a corporation, existing under the laws of the State of Oregon, (“Public Utility”). The Interconnection Customer and Public Utility may be referred to hereinafter singly as a “Party” or collectively as the “Parties.”

### **Recitals:**

**Whereas**, the Interconnection Customer is proposing to develop a Community Solar Project, consistent with the Application completed on February 4, 2021;

**Whereas**, the Interconnection Customer desires to interconnect the Community Solar Project with Public Utility’s Distribution System (“Distribution System”) in the State of Oregon; and

**Whereas**, the interconnection of the Community Solar Project and the Public Utility’s Distribution System is subject to the jurisdiction of the Public Utility Commission of Oregon (“Commission”) and are governed by OPUC Rule OAR 860, Division 088 (the “Rule”) and Public Utility’s Community Solar Interconnection Procedures (“CSP Interconnection Procedures”)

**Now, therefore**, in consideration of and subject to the mutual covenants contained herein, the Parties agree as follows:

### **Article 1.      **Scope and Limitations of Agreement****

#### **1.1      **Scope****

This Agreement establishes the standard terms and conditions under which the Community Solar Project with a Nameplate Capacity of no more than 3 megawatts (“MW”) will interconnect to, and operate in Parallel with, the Public Utility’s Distribution System. The Commission has approved standard terms and conditions governing this class of interconnection. Any additions, deletions or changes to the standard terms and conditions of interconnection as mutually agreed to by the Parties must be approved by the Commission. Terms with initial capitalization, when used in this Agreement, shall have the meanings given in the CSP Interconnection Procedures. This Agreement shall be construed where possible to be consistent with the Rule and the CSP Interconnection Procedures; to the extent this Agreement conflicts with the Rule or the CSP Interconnection Procedures, the Rule or CSP Interconnection Procedures shall take precedence.

#### **1.2      **Definitions****

Unless defined in this Agreement, when used in this Agreement, with initial capitalization, the terms specified shall have the meanings given in CSP Interconnection Procedures.

#### **1.3      **No Agreement Regarding Power Purchase, Transmission, or Delivery****

This Agreement does not constitute an agreement to purchase, transmit, or deliver any power



## **Interconnection Agreement for a Community Solar Project**

or capacity from the interconnected Community Solar Project nor does it constitute an electric service agreement.

### **1.4 Other Agreements**

Nothing in this Agreement is intended to affect any other agreement between the Public Utility and the Interconnection Customer or any other interconnected entity. If the provisions of this Agreement conflict with the provisions of any other Public Utility tariff or the CSP Interconnection Procedures, the Public Utility tariff or CSP Interconnection Procedures, as applicable, shall control.

### **1.5 Responsibilities of the Parties**

1.5.1 The Parties shall perform all obligations of this Agreement in accordance with all applicable laws.

1.5.2 The Interconnection Customer will construct, own, operate, and maintain its Community Solar Project in accordance with this Agreement, IEEE Standard 1547 (2003 ed), IEEE Standard 1547.1 (2005 ed), the National Electrical Code (2005 ed) and applicable standards required by the Commission and this Agreement.

1.5.3 Each Party shall be responsible for the safe installation, maintenance, repair and condition of their respective lines and appurtenances on their respective sides of the Point of Interconnection. Each Party shall provide Interconnection Facilities that adequately protect the other Parties' facilities, personnel, and other persons from damage and injury. The allocation of responsibility for the design, installation, operation, maintenance and ownership of Interconnection Facilities is prescribed in the Rule and this Agreement and the attachments to this Agreement.

### **1.6 Parallel Operation and Maintenance Obligations**

Once the Community Solar Project has been authorized to commence Parallel Operation by execution of this Agreement and satisfaction of Article 2.1 of this Agreement, the Interconnection Customer will abide by all written provisions for operating and maintenance as required by this Agreement and any attachments to this Agreement as well as by the Rule and as detailed by the Public Utility in a certification form, "Operations Form", title "Interconnection Equipment As-Built Specifications, Initial Settings and Operating Requirements."

### **1.7 Metering & Monitoring**

The Interconnection Customer will be responsible for metering and monitoring as required by the CSP Interconnection Procedures and as may be detailed in any attachments to this Agreement.

### **1.8 Power Quality**

The Interconnection Customer will design its Community Solar Project to maintain a composite power delivery at continuous rated power output at the Point of Interconnection





## **Interconnection Agreement for a Community Solar Project**

that meets the requirements set forth in IEEE 1547. The Public Utility may, in some circumstances, also require the Interconnection Customer to follow voltage or VAR schedules used by similarly situated, comparable generators in the control area. Any special operating requirements will be detailed in Operations Form and completed by the Public Utility as required by the Rule. The Public Utility shall not impose additional requirements for voltage or reactive power support outside of what may be required to mitigate impacts caused by interconnection of the Community Solar Project to the Public Utility's system.

### **Article 2. Inspection, Testing, Authorization, and Right of Access**

#### **2.1 Equipment Testing and Inspection**

The Interconnection Customer will test and inspect its Community Solar Project and Interconnection Facilities prior to interconnection in accordance with IEEE 1547 Standards as provided for in the Rule. The Interconnection will not be final and the Community Solar Project shall not be authorized to operate in parallel with the Public Utility's Distribution System until the Witness Test and Certificate of Completion provisions in the Rule have been satisfied. The Interconnection Customer shall pay or reimburse the Public Utility for its costs to participate in the Witness Test. Operation of the Community Solar Project requires an effective Interconnection Agreement; electricity sales require a power purchase agreement.

To the extent that the Interconnection Customer decides to conduct interim testing of the Community Solar Project prior to the Witness Test, it may request that the Public Utility observe these tests. If the Public Utility agrees to send qualified personnel to observe any interim testing proposed by the Interconnection Customer, the Interconnection Customer shall pay or reimburse the Public Utility for its cost to participate in the interim testing. If the Interconnection Customer conducts interim testing and such testing is observed by the Public Utility and the results of such interim testing are deemed acceptable by the Public Utility (hereinafter a "Public Utility-approved interim test"), then the Interconnection Customer may request that such Public Utility-approved interim test be deleted from the final Witness Testing. If the Public Utility elects to repeat any Public Utility-approved interim test as part of the final Witness Test, the Public Utility will bare its own expenses associated with participation in the repeated Public Utility-approved interim test.

#### **2.2 Right of Access:**

As provided in the CSP Interconnection Procedures, the Public Utility will have access to the Interconnection Customer's premises for any reasonable purpose in connection with the Interconnection Application or any Interconnection Agreement that is entered in to pursuant to the Rule and CSP Interconnection Procedures or if necessary to meet the legal obligation to provide service to its customers. Access will be requested at reasonable hours and upon reasonable notice, or at any time without notice in the event of an emergency or hazardous condition.



## Interconnection Agreement for a Community Solar Project

### **Article 3. Effective Date, Term, Termination, and Disconnection**

#### **3.1 Effective Date**

The Agreement shall become effective upon execution by the Parties.

#### **3.2 Term of Agreement**

The Agreement will be effective on the Effective Date and will remain in effect for a period of twenty (20) years from the commercial operations date or the life of the power purchase agreement, whichever is shorter.

#### **3.3 Termination**

No termination will become effective until the Parties have complied with all provisions of the CSP Interconnection Procedures and this Agreement that apply to such termination.

3.3.1 The Interconnection Customer may terminate this Agreement at any time by giving the Public Utility twenty (20) Business Days written notice.

3.3.2 Either Party may terminate this Agreement after default pursuant to Article 5.6 of this Agreement.

3.3.3 The Commission may order termination of this Agreement.

3.3.4 Upon termination of this Agreement, the Community Solar Project will be disconnected from the Public Utility's Distribution System at the Interconnection Customer's expense. The termination of this Agreement will not relieve either Party of its liabilities and obligations, owed or continuing at the time of the termination.

3.3.5 The provisions of this Article 3.3 shall survive termination or expiration of this Agreement.

#### **3.4 Temporary Disconnection**

The Public Utility or Interconnection Customer may temporarily disconnect the Community Solar Project from the Public Utility's Distribution System for so long as reasonably necessary, as provided in the CSP Interconnection Procedures, in the event one or more of the following conditions or events occurs:

3.4.1 Under emergency conditions, the Public Utility or the Interconnection Customer may immediately suspend interconnection service and temporarily disconnect the Community Solar Project without advance notice to the other Party. The Public Utility shall notify the Interconnection Customer promptly when it becomes aware of an emergency condition that may reasonably be expected to affect the Community Solar Project operation. The Interconnection Customer will notify the Public Utility promptly when it becomes aware of an emergency condition that may reasonably be expected to affect the Public Utility's Distribution System. To the extent information is known, the notification shall describe the emergency condition, the extent of the



## Interconnection Agreement for a Community Solar Project

damage or deficiency, the expected effect on the operation of both Parties' facilities and operations, its anticipated duration, and the necessary corrective action.

- 3.4.2 For routine Maintenance, Parties will make reasonable efforts to provide five Business Days' notice prior to interruption caused by routine maintenance or construction and repair to the Community Solar Project or Public Utility's Distribution System and shall use reasonable efforts to coordinate such interruption.
- 3.4.3 The Public Utility shall use reasonable efforts to provide the Interconnection Customer with prior notice of forced outages of the Distribution System. If prior notice is not given, the Public Utility shall, upon request, provide the Interconnection Customer written documentation after the fact explaining the circumstances of the disconnection.
- 3.4.4 For disruption or deterioration of service, where the Public Utility determines that operation of the Community Solar Project will likely cause disruption or deterioration of service to other customers served from the same electric system, or if operating the Community Solar Project could cause damage to the Public Utility's Distribution System, the Public Utility may disconnect the Community Solar Project. The Public Utility will provide the Interconnection Customer upon request all supporting documentation used to reach the decision to disconnect. The Public Utility may disconnect the Community Solar Project if, after receipt of the notice, the Interconnection Customer fails to remedy the adverse operating effect within a reasonable time which shall be at least five Business Days from the date the Interconnection Customer receives the Public Utility's written notice supporting the decision to disconnect, unless emergency conditions exist, in which case the provisions of 3.4.1 of the agreement apply.

### **3.5 Restoration of interconnection:**

The Parties shall cooperate with each other to restore the Community Solar Project, Interconnection Facilities, and Public Utility's Distribution System to their normal operating state as soon as reasonably practicable following any disconnection pursuant to Article 3.4.

## **Article 4. Cost Responsibility and Billing:**

As provided in the CSP Interconnection Procedures, the Applicant is responsible for the cost of all facilities, equipment, modifications and upgrades needed to facilitate the interconnection of the Community Solar Project to the Public Utility's Distribution System.

### **4.1 Minor Distribution System Modifications:**

As provided in the CSP Interconnection Procedures addressing Tier 2 review, it may be necessary for the Parties to construct certain Minor Modifications to interconnect under Tier 2 review. The Public Utility has itemized any required Minor Modifications in the



## **Interconnection Agreement for a Community Solar Project**

attachments to this Agreement, including a good-faith estimate of the cost of such Minor Modifications and the time required to build and install such Minor Modifications. The Interconnection Customer agrees to pay the costs of such Minor Modifications.

### **4.2 Interconnection Facilities:**

The Public Utility has identified under the review procedures of a Tier 2 review or under a Tier 4 Facilities Study, the Interconnection Facilities necessary to safely interconnect the Community Solar Project with the Public Utility. The Public Utility has itemized the required Interconnection Facilities in the attachments to this Agreement, including a good-faith estimate of the cost of the facilities and the time required to build and install those facilities. The Applicant is responsible for the cost of the Interconnection Facilities.

### **4.3 Interconnection Equipment:**

The Applicant is responsible for all reasonable expenses, including overheads, associated with owning, operating, maintaining, repairing, and replacing its Interconnection Equipment.

### **4.4 System Upgrades:**

The Public Utility will design, procure, construct, install, and own any System Upgrades. The actual cost of the System Upgrades, including overheads, will be directly assigned to an Applicant. In such cases when there are multiple Community Solar Facilities on a single circuit of the Distribution System that are jointly studied, the Public Utility shall allocate the System Upgrade costs based on the proportional capacity of each Community Solar Project. The cost sharing will be detailed in the Attachments to this Agreement. If a Community Solar Project that has been jointly studied and allocated a share of system upgrade costs withdraws, the Company will reassess the System Upgrades needed to complete the interconnection(s) and reallocate the System Upgrade costs to the remaining Community Solar Project(s) using the same methodology.

### **4.5 Adverse System Impact:**

The Public Utility is responsible for identifying the possible Affected Systems and coordinating with those identified Affected Systems, to the extent reasonably practicable, to allow the Affected System owner an opportunity to identify Adverse System Impacts on its Affected System, and to identify what mitigation activities or upgrades may be required on the Public Utility's system or on the Affected System to address impacts on Affected Systems and accommodate a Community Solar Project. Such coordination with Affected System owners shall include inviting Affected System owners to scoping meetings between the Public Utility and the Applicant and providing the Affected System owner with study results and other information reasonably required and requested by the Affected System owner to allow the Affected System owner to assess impacts to its system and determine required mitigation, if any, for such impacts. The Parties acknowledge that the Public Utility cannot compel the participation of the Affected System owner and that the Public Utility is not itself responsible for identifying impacts or mitigation associated with an Affected System. The actual cost of any actions taken to address the Adverse System Impacts, including overheads, shall be directly assigned to the Interconnection Customer. The



## Interconnection Agreement for a Community Solar Project

Interconnection Customer may be entitled to financial compensation from other Public Utilities or other Interconnection Customers who, in the future, utilize the upgrades paid for by the Interconnection Customer, to the extent allowed or required by the Commission. Such compensation will only be available to the extent provided for in the separate rules or Commission order. If the Parties have actual knowledge of an Adverse System Impact on an Affected System, the Applicant shall not interconnect and operate its Community Solar Project in parallel with the Public Utility's system, and the Public Utility shall not authorize or allow the continued interconnection or parallel operation of the Community Solar Project, unless and until such Adverse System Impact has been addressed to the reasonable satisfaction of the Affected System owner.

### 4.6 Deposit and Billings:

The Applicant agrees to pay to the Public Utility a deposit toward the cost to construct and install any required Interconnection Facilities and/or System Upgrades. The amount of the deposit shall be (select one of the following):

The Parties have agreed to progress payments and final payment under the schedule of payments attached to this Agreement; the Applicant shall pay a deposit equal to the lesser of (a) 25 percent of the estimated cost of the Interconnection Facilities and System Upgrades, or (b) \$10,000 – the amount of the deposit shall be \$10,000.

or

The Parties have not agreed to progress payments, the Applicant shall pay 100% of estimated costs as detailed in the Attachments to this agreement prior to the commencement of work.

If the actual costs of Interconnection Facilities and/or System Upgrades are different than the deposit amounts and/or progress and final payments provided for above, then the Applicant shall pay the Public Utility any balance owing or the Public Utility shall refund any excess deposit or progress payment within 20 Business Days of the date actual costs are determined.

If the Applicant's request to interconnect was jointly studied by the Company and the Applicant withdrawals, then any deposits or payments made by the withdrawing Applicant will be applied as a bill credit to not-yet-invoiced study costs for other remaining CSP Applicants that were jointly studied. Any remaining deposits or payments after the bill credits have been issued will be returned to the withdrawing Applicant.

## **Article 5. Assignment, Liability, Indemnity, Force Majeure, Consequential Damages, and Default**

### 5.1 Assignment

The Interconnection Agreement may be assigned by either Party upon fifteen (15) Business Days prior written notice. Except as provided in Articles 5.1.1 and 5.1.2, said assignment



## Interconnection Agreement for a Community Solar Project

shall only be valid upon the prior written consent of the non-assigning Party, which consent shall not be unreasonably withheld.

- 5.1.1 Either Party may assign the Agreement without the consent of the other Party to any affiliate (which shall include a merger of the Party with another entity), of the assigning Party with an equal or greater credit rating and with the legal authority and operational ability to satisfy the obligations of the assigning Party under this Agreement;
- 5.1.2 The Interconnection Customer shall have the right to assign the Agreement, without the consent of the Public Utility, for collateral security purposes to aid in providing financing for the Community Solar Project. For Community Solar Project systems that are integrated into a building facility, the sale of the building or property will result in an automatic transfer of this agreement to the new owner who shall be responsible for complying with the terms and conditions of this Agreement.
- 5.1.3 Any attempted assignment that violates this Article is void and ineffective. Assignment shall not relieve a Party of its obligations, nor shall a Party's obligations be enlarged, in whole or in part, by reason thereof. An assignee is responsible for meeting the same obligations as the assigning Interconnection Customer.
- 5.1.4 Any assignment not specifically approved by the Project Manager or the Program Administrator shall similarly be declared void and ineffective.

### **5.2 Limitation of Liability and Consequential Damages**

A Party is liable for any loss, cost claim, injury, or expense including reasonable attorney's fees related to or arising from any act or omission in its performance of the provisions of this Agreement entered into pursuant to the Rule except as provided for in ORS 757.300(4)(c). Neither Party will seek redress from the other Party in an amount greater than the amount of direct damage actually incurred.

### **5.3 Indemnity**

- 5.3.1 Liability under this Article 5.3 is exempt from the general limitations on liability found in Article 5.2.
- 5.3.2 The Parties shall at all times indemnify, defend, and hold the other Party harmless from, any and all damages, losses, claims, including claims and actions relating to injury to or death of any person or damage to property, demand, suits, recoveries, costs and expenses, court costs, attorney fees, and all other obligations by or to third parties, arising out of or resulting from the other Party's action or failure to meet its obligations under this Agreement on behalf of the indemnifying party, except in cases of gross negligence or intentional wrongdoing by the indemnified person.

## **Interconnection Agreement for a Community Solar Project**

- 5.3.3 If an indemnified person is entitled to indemnification under this Article 5.3 as a result of a claim by a third party, and the indemnifying party fails, after notice and reasonable opportunity to proceed under this Article 5.3, to assume the defense of such a claim, such indemnified person may at the expense of the indemnifying Party contest, settle or consent to the entry of any judgment with respect to, or pay in full, such claim.
- 5.3.4 If an indemnifying party is obligated to indemnify and hold any indemnified person harmless under this Article 5.3, the amount owing to the indemnified person shall be the amount of such indemnified person's actual loss, net of any insurance or other recovery.
- 5.3.5 Promptly after receipt by an indemnified person of any claim or notice of the commencement of any action or administrative or legal proceeding or investigation as to which the indemnity provided for in this Article 5.3 may apply, the indemnified person shall notify the indemnifying party of such fact. Any failure of or delay in such notification shall not affect a Party's indemnification obligation unless such failure or delay is materially prejudicial to the indemnifying party.
- 5.3.6 The indemnifying party shall have the right to assume the defense thereof with counsel designated by such indemnifying party and reasonably satisfactory to the indemnified person. If the defendants in any such action include one or more indemnified persons and the indemnifying party and if the indemnified person reasonably concludes that there may be legal defenses available to it and/or other indemnified persons which are different from or additional to those available to the indemnifying party, the indemnified person shall have the right to select separate counsel to assert such legal defenses and to otherwise participate in the defense of such action on its own behalf. In such instances, the indemnifying party shall only be required to pay the fees and expenses of one additional attorney to represent an indemnified person or indemnified persons having such differing or additional legal defenses.
- 5.3.7 The indemnified person shall be entitled, at its expense, to participate in any such action, suit or proceeding, the defense of which has been assumed by the indemnifying party. Notwithstanding the foregoing, the indemnifying party (i) shall not be entitled to assume and control the defense of any such action, suit or proceedings if and to the extent that, in the opinion of the indemnified person and its counsel, such action, suit or proceeding involves the potential imposition of criminal liability on the indemnified person, or there exists a conflict or adversity of interest between the indemnified person and the indemnifying Party, in such event the indemnifying Party shall pay the reasonable expenses of the indemnified person, and (ii) shall not settle or consent to the entry of any judgment in any action, suit or proceeding without the consent of the indemnified person, which shall not be reasonably withheld, conditioned or delayed.

## **Interconnection Agreement for a Community Solar Project**

### **5.4 Consequential Damages**

Neither Party shall be liable to the other Party, under any provision of this Agreement, for any losses, damages, costs or expenses for any special, indirect, incidental, consequential, or punitive damages, including but not limited to loss of profit or revenue, loss of the use of equipment, cost of capital, cost of temporary equipment or services, whether based in whole or in part in contract, in tort, including negligence, strict liability, or any other theory of liability; provided, however, that damages for which a Party may be liable to the other Party under another agreement will not be considered to be special, indirect, incidental, or consequential damages hereunder.

### **5.5 Force Majeure**

5.5.1 As used in this Agreement, a Force Majeure Event shall mean “any act of God, labor disturbance, act of the public enemy, war, acts of terrorism, insurrection, riot, fire, storm or flood, explosion, breakage or accident to machinery or equipment through no direct, indirect, or contributory act of a Party, any order, regulation or restriction imposed by governmental, military or lawfully established civilian authorities, or any other cause beyond a Party’s control. A Force Majeure Event does not include an act of negligence or intentional wrongdoing.”

5.5.2 If a Force Majeure Event prevents a Party from fulfilling any obligations under this Agreement, the Party affected by the Force Majeure Event (Affected Party) shall promptly notify the other Party of the existence of the Force Majeure Event. The notification must specify in reasonable detail the circumstances of the Force Majeure Event, its expected duration, and the steps that the Affected Party is taking to mitigate the effects of the event on its performance, and if the initial notification was verbal, it should be promptly followed up with a written notification. The Affected Party shall keep the other Party informed on a continuing basis of developments relating to the Force Majeure Event. Until the Force Majeure Event ends the Affected Party will be entitled to suspend or modify its performance of obligations under this Agreement (other than the obligation to make payments) only to the extent that the effect of the Force Majeure Event cannot be reasonably mitigated. The Affected Party will use reasonable efforts to resume its performance as soon as possible. The Parties shall immediately report to the Commission should a Force Majeure Event prevent performance of an action required by the Rule that the Rule does not permit the Parties to mutually waive.

### **5.6 Default**

5.6.1 No default shall exist where such failure to discharge an obligation (other than the payment of money) is the result of a Force Majeure Event as defined in this Agreement, or the result of an act or omission of the other Party. Upon a breach, the non-breaching Party shall give written notice of such breach to the breaching Party. Except as provided in Article 5.6.2, the breaching Party shall have sixty (60) Calendar Days from receipt of the beach notice within which to cure such breach;



## **Interconnection Agreement for a Community Solar Project**

provided however, if such breach is not capable of cure within 60 Calendar Days, the breaching Party shall commence such cure within twenty (20) Calendar Days after notice and continuously and diligently complete such cure within six months from receipt of the breach notice; and, if cured within such time, the breach specified in such notice shall cease to exist.

- 5.6.2 If a breach is not cured as provided for in this Article 5.6, or if a breach is not capable of being cured within the period provided for herein, the non-breaching Party shall have the right to declare a default and terminate this Agreement by written notice at any time until cure occurs, and be relieved of any further obligation hereunder and, whether or not that Party terminates this Agreement, to recover from the breaching Party all amounts due hereunder, plus all other damages and remedies to which it is entitled at law or in equity. Alternatively, the non-breaching Party shall have the right to seek dispute resolution with the Commission in lieu of default. The provisions of this Article 5.6 will survive termination of the Agreement.

### **Article 6. Insurance**

- 6.1** The Public Utility may not require the Community Solar Project to maintain general liability insurance in relation to the interconnection of the Community Solar Project with an Electric Nameplate Capacity of 200 kW or less. With regard to the interconnection of a Community Solar Project, the Interconnection Customer shall, at its own expense, maintain in force throughout the period of this Agreement general liability insurance sufficient to protect any person (including the Public Utility) who may be affected by the Interconnection Customer's Community Solar Project and its operation and such insurance shall be sufficient to satisfy the Interconnection Customer's indemnification responsibilities under Article 5.3 of this Agreement.
- 6.2** Within ten (10) days following execution of this Agreement, and as soon as practicable after the end of each fiscal year or at the renewal of the insurance policy and in any event within ninety (90) days thereafter, the Interconnection Customer shall provide the Public Utility with certification of all insurance required in this Agreement, executed by each insurer or by an authorized representative of each insurer.
- 6.3** All insurance required by this Article 6 shall name the Public Utility, its parent, associated and Affiliate companies and their respective directors, officers, agents, servants and employees ("Other Party Group") as additional insured. All policies shall contain provisions whereby the insurers waive all rights of subrogation against the Other Party Group and provide thirty (30) Calendar Days advance written notice to the Other Party Group prior to anniversary date of cancellation or any material change in coverage or condition. The Interconnection Customer's insurance shall contain provisions that specify that the policies are primary and shall apply to such extent without consideration for other policies separately carried and shall state that each insured is provided coverage as though a separate policy had been issued to each, except the insurer's liability shall not be increased beyond the amount for which the insurer would have been liable had only one insured been covered. The



## **Interconnection Agreement for a Community Solar Project**

insurance policies, if written on a Claims First Made Basis, shall be maintained in full force and effect for two (2) years after termination of this Agreement, which coverage may be in the form of tail coverage or extended reporting period coverage if agreed by the Parties.

- 6.4 The Parties agree to report to each other in writing as soon as practical all accidents or occurrences resulting in injuries to any person, including death, and any property damage arising out of this Agreement.
- 6.5 The requirements contained herein as to insurance are not intended to and shall not in any manner, limit or qualify the liabilities and obligations assumed by the Parties under this Agreement.

### **Article 7. Dispute Resolution**

Parties will adhere to the dispute resolution provisions in the CSP Interconnection Procedures.

### **Article 8. Miscellaneous**

#### **8.1 Governing Law, Regulatory Authority, and Rules**

The validity, interpretation and enforcement of the Agreement and each of its provisions shall be governed by the laws of the State of Oregon, without regard to its conflicts of law principles. The Agreement is subject to all applicable laws. Each Party expressly reserves the right to seek changes in, appeal, or otherwise contest any laws, orders, or regulations of a governmental authority.

#### **8.2 Amendment**

The Parties may mutually agree to amend the Agreement by a written instrument duly executed by both Parties in accordance with provisions of the Rule and applicable Commission Orders and provisions of the laws of the State of Oregon.

#### **8.3 No Third-Party Beneficiaries**

The Agreement is not intended to and does not create rights, remedies, or benefits of any character whatsoever in favor of any persons, corporations, associations, or entities other than the Parties, and the obligations herein assumed are solely for the use and benefit of the Parties, their successors in interest and where permitted, their assigns.

#### **8.4 Waiver**

- 8.4.1 The failure of a Party to the Agreement to insist, on any occasion, upon strict performance of any provision of the Agreement will not be considered a waiver of any obligation, right, or duty of, or imposed upon, such Party.
- 8.4.2 The Parties may agree to mutually waive a section of this Agreement so long as prior Commission approval of the waiver is not required by the Rule.



## **Interconnection Agreement for a Community Solar Project**

8.4.3 Any waiver at any time by either Party of its rights with respect to the Agreement shall not be deemed a continuing waiver or a waiver with respect to any other failure to comply with any other obligation, right, duty of the Agreement. Any waiver of the Agreement shall, if requested, be provided in writing.

### **8.5 Entire Agreement**

This Agreement, including any supplementary Form attachments that may be necessary, constitutes the entire agreement between the Parties with reference to the subject matter hereof, and supersedes all prior and contemporaneous understandings or agreements, oral or written, between the Parties with respect to the subject matter of the Agreement. There are no other agreements, representations, warranties, or covenants that constitute any part of the consideration for, or any condition to, either Party's compliance with its obligations under this Agreement.

### **8.6 Multiple Counterparts**

This Agreement may be executed in two or more counterparts, each of which is deemed an original but all constitute one and the same instrument.

### **8.7 No Partnership**

This Agreement will not be interpreted or construed to create an association, joint venture, agency relationship, or partnership between the Parties or to impose any partnership obligation or partnership liability upon either Party. Neither Party shall have any right, power or authority to enter into any agreement or undertaking for, or act on behalf of, or to act as or be an agent or representative of, or to otherwise bind, the other Party.

### **8.8 Severability**

If any provision or portion of this Agreement shall for any reason be held or adjudged to be invalid or illegal or unenforceable by any court of competent jurisdiction or other governmental authority; (1) such portion or provision shall be deemed separate and independent; (2) the Parties shall negotiate in good faith to restore insofar as practicable the benefits to each Party that were affected by such ruling; and (3) the remainder of this Agreement shall remain in full force and effect.

### **8.9 Subcontractors**

Nothing in this Agreement shall prevent a Party from utilizing the services of any subcontractor, or designating a third party agent as one responsible for a specific obligation or act required in this Agreement (collectively subcontractors), as it deems appropriate to perform its obligations under this Agreement; provided, however, that each Party will require its subcontractors to comply with all applicable terms and conditions of this Agreement in providing such services and each Party will remain primarily liable to the other Party for the performance of such subcontractor.

8.9.1 The creation of any subcontract relationship shall not relieve the hiring Party of any of its obligations under this Agreement. The hiring Party shall be fully responsible to the other Party for the acts or omissions of any subcontractor the hiring Party hires



## Interconnection Agreement for a Community Solar Project

as if no subcontract had been made. Any applicable obligation imposed by this Agreement upon the hiring Party shall be equally binding upon, and will be construed as having application to, any subcontractor of such Party.

8.9.2 The obligations under this Article 8.9 will not be limited in any way by any limitation of subcontractor's insurance.

### 8.10 Reservation of Rights

Either Party will have the right to make a unilateral filing with the Commission to modify this Agreement. This reservation of rights provision will include but is not limited to modifications with respect to any rates terms and conditions, charges, classification of service, rule or regulation under CSP Interconnection Procedures rates or any applicable State or Federal law or regulation. Each Party shall have the right to protest any such filing and to participate fully in any proceeding before the Commission in which such modifications may be considered.

## Article 9. Notices and Records

### 9.1 General

Unless otherwise provided in this Agreement, any written notice, demand, or request required or authorized in connection with this Agreement shall be deemed properly given if delivered in person, delivered by recognized national courier service, or sent by first class mail, postage prepaid, to the person specified below:

### 9.2 Records

The Public Utility will maintain a record of all Interconnection Agreements and related Form attachments for as long as the interconnection is in place as required by the CSP Interconnection Procedures. The Public Utility will provide a copy of these records to the Interconnection Customer within 15 Business Days if a request is made in writing.

#### **If to the Interconnection Customer:**

Interconnection Customer: Buckaroo Solar 2, LLC  
Attention: Daniel Hale  
Address: PO Box 549  
City: Stanfield State: OR Zip: 97875  
Phone: 323-480-3835 E-mail: PM2@buckaroosolar.com

#### **If to Public Utility:**

Public Utility: PacifiCorp  
Attention: Transmission Services  
Address: 825 N.E. Multnomah Street, Suite 550



## Interconnection Agreement for a Community Solar Project

City: Portland State: OR Zip: 97232  
Phone: 503-813-6077 Fax: 503-813-6873

### 9.3 Billing and Payment

Billings and payments shall be sent to the addresses set out below: (complete if different than article 9.2 above)

#### If to the Interconnection Customer

Interconnection Customer: Buckaroo Solar 2, LLC  
Attention: Daniel Hale  
Address: PO Box 549  
City: Stanfield State: OR Zip: 97875  
Phone: 323-480-3835 E-mail: PM2@buckaroosolar.com

#### If to Public Utility

Public Utility: PacifiCorp Transmission  
Attention: Central Cashiers Office  
Address: 825 N.E. Multnomah Street, Suite 550  
City: Portland State: OR Zip: 97232

### 9.4 Designated Operating Representative

The Parties will designate operating representatives to conduct the communications which may be necessary or convenient for the administration of the operations provisions of this Agreement. This person will also serve as the point of contact with respect to operations and maintenance of the Party's facilities (complete if different than article 9.2 above)

#### Interconnection Customer's Operating Representative:

Interconnection Customer: Buckaroo Solar 1, LLC  
Attention: Daniel Hale  
Address: PO Box 549  
City: Stanfield State: OR Zip: 97875  
Phone: 323-480-3835 E-mail: PM1@buckaroosolar.com

#### Public Utility's Operating Representative: PacifiCorp

Attention: Grid Operations  
Address: 9915 S.E. Ankeny Street  
City: Portland State: OR Zip: 97216  
Phone: 503-251-5197 Fax: 503-251-5228



## Interconnection Agreement for a Community Solar Project

### 9.5 Changes to the Notice Information

Either Party may change this notice information by giving five Business Days written notice prior to the effective date of the change.

### Article 10. Signatures

IN WITNESS WHEREOF, the Parties have caused this Agreement to be executed by their respective duly authorized representatives.

#### For Public Utility:

Name: **Rick Vail** Digitally signed by Rick Vail  
Date: 2022.09.01 05:57:38 -07'00'

Rick Vail

Title: VP, Transmission

Date: 09/01/2022

#### For the Applicant/Interconnection Customer:

Name: D Hale

Daniel Hale

Title: Managing Member

Date: 8/25/2022



## Interconnection Agreement for a Community Solar Project

### Attachment 1

#### Description of Interconnection Facilities And Metering Equipment Operated or Maintained by the Public Utility

**Community Solar Project:** Forty-nine (49) CHINT SCA60KTL 60 kW inverters connect to two (2) 1.5 MVA 480V – 12.47kV transformers (Z=5.75%), on the transformers high-side is a 200 kVA grounding bank (Z=5.75%). Total requested output is 2.99 MW. See Attachment 2.

**Interconnection Customer Interconnection Facilities:** A relay controlled recloser and Public Utility accessible disconnect switch. See Attachment 2.

**Public Utility's Interconnection Facilities:** Bi-directional metering, transfer trip equipment, disconnect switch, and associated poles/structures. See Attachment 2.

**Estimated Cost of Public Utility's Interconnection Facilities:** Estimated cost of Public Utility's Interconnection Facilities directly assigned to Interconnection Customer: \$161,000.

**Estimated Annual Operation and Maintenance Cost of Public Utility's Interconnection Facilities:** \$250.

Interconnection Customer shall be responsible for Public Utility's actual cost for maintenance of the Public Utility's Interconnection Facilities.

**Point of Interconnection:** The point where the Public Utility's Interconnection Facilities connect to the Public Utility's 12.47 kV distribution circuit 5W202 out of Buckaroo substation. See Attachment 2.

**Point of Change of Ownership:** The point where the Interconnection Customer's Interconnection Facilities connect to the Public Utility's Interconnection Facilities. See Attachment 2.



# Interconnection Agreement for a Community Solar Project

## Attachment 2

### One-line Diagram Depicting the Generating Facility, Interconnection Facilities, and Metering Equipment

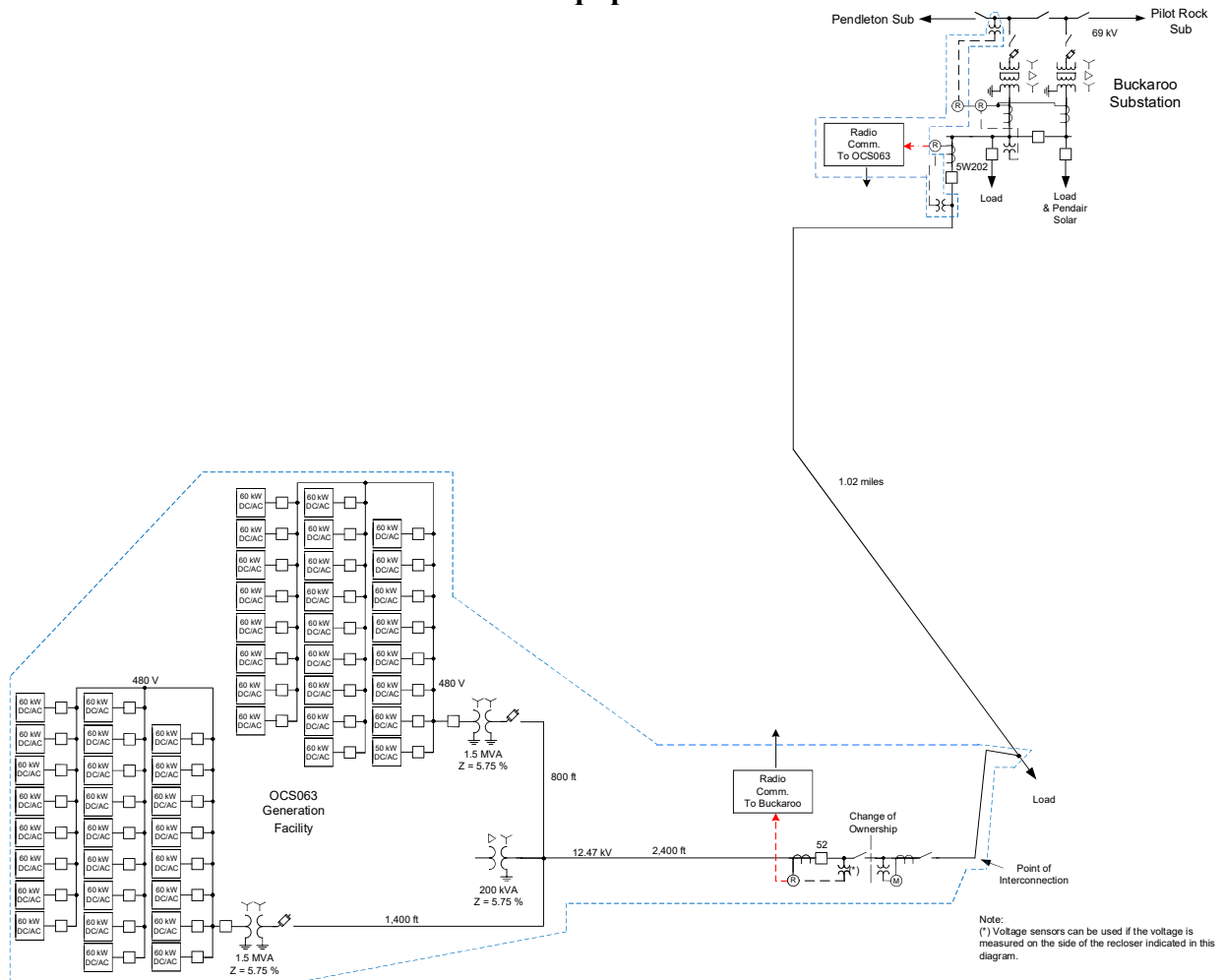





## Interconnection Agreement for a Community Solar Project

### Attachment 3

#### Milestones

Estimated In-Service Date: July 21, 2023

Critical milestones and responsibility as agreed to by the Parties:

<b>Milestone/Date</b>	<b>Responsible Party</b>
Execute Interconnection Agreement September 2, 2022	Applicant
Provision of First Progress Payment September 2, 2022	Applicant
Applicant and Public Utility Establish Retail Service Request September 16, 2022	Both Parties
*Applicant Initial Design Package Provided September 16, 2022	Applicant
Public Utility Engineering & Procurement Commences October 17, 2022	Public Utility
Applicant Property/Permits/ROW Procured October 31, 2022	Applicant
Public Utility Property/Permits/ROW Procured January 6, 2023	Public Utility
*Applicant Final Design Package Provided February 1, 2023	Applicant
Public Utility Engineering Design Complete June 9, 2023	Public Utility
Construction Begins July 24, 2023	Public Utility
Applicant Maintenance and Commissioning Plans Provided August 11, 2023	Applicant
Applicant and Public Utility Construction Complete	Both Parties



## Interconnection Agreement for a Community Solar Project

November 9, 2023

Public Utility Commissioning Activities Complete  
November 15, 2023

Public Utility

Public Utility Commissioning Document Review Complete  
November 21, 2023

Public Utility

Applicant’s Facilities Receive Backfeed Power  
November 22, 2023

Applicant

Initial Synchronization/Generation Testing  
November 28, 2023

Applicant

Commercial Operation  
November 30, 2023

Interconnection Customer

Interconnection Customer is to request Backfeed, 1<sup>st</sup> Sync, and Commercial Operations in writing (email acceptable) prior to the above dates. Public Utility is to approve Interconnection Customer requests without unreasonable delay. The Interconnection Customer will be required to demonstrate the reactive capability of the Community Solar Project and the voltage control system prior to Commercial Operations.

\* Any design modifications to the Interconnection Customer’s Community Solar Project after this date requiring updates to the Public Utility’s network model will result in a minimum of 3 months added to all future milestones including Commercial Operations.

### Payment Schedule\*

If Interconnection Customer agrees to progress payments option under Article 4.6 of the Interconnection Agreement, there are two potential options for a payment schedule below (please select one). If Interconnection Customer elects progress payment option but an option below is not selected, the Levelized Option will be selected by default. Failure to comply with the selected payment schedule will result in contractual breach, work stoppage, and slip of the milestone schedule above on a day-for-day basis. Interconnection Customer will still be responsible for all costs of the project. Public Utility will conduct initial accounting for the project within thirty (30) days of granting Commercial Operations approval and will determine if a partial refund of project costs is acceptable.

Please select an option:

Funds due no later than  
September 2, 2022

Levelized Option

Stepped Option

(or when Interconnection  
Agreement is executed)

\$10,000

\$10,000



## Interconnection Agreement for a Community Solar Project

October 31, 2022	\$118,000	\$47,200
January 6, 2023	\$118,000	\$94,400
April 6, 2023	\$118,000	\$141,600
July 14, 2023	\$118,000	\$188,800

\*Please see Attachments 5 and 6 for further information as estimated costs may change during detailed engineering.



## Interconnection Agreement for a Community Solar Project

### Attachment 4

#### **Additional Operating Requirements for the Public Utility's Transmission System and/or Distribution System and Affected Systems Needed to Support the Interconnection Customer's Needs**

The interconnection of the Community Solar Project is subject to the rules contained within the CSP Interconnection Procedures. The interconnection of the Community Solar Project to the Public Utility's Distribution System shall be subject to, and the Interconnection Customer shall operate the Community Solar Project in accordance with, the Public Utility's policies governing interconnection of generation facilities to the Distribution System entitled "Facility Connection (Interconnection) Requirements for Distribution Systems (34.5 kV and below)" (or, "Policy 138") which policy document is available upon request from the Public Utility and is incorporated by this reference as part of the Interconnection Agreement between the Parties. In the event of a conflict between any aspect of this Attachment 4 (including without limitation the Public Utility's policies governing interconnection of generation facilities to the distribution system or the transmission system) and the rules contained in the CSP Interconnection Procedures, the rules shall prevail.

Parallel Operation. Interconnection Customer may operate the Community Solar Project in parallel with the Public Utility's Transmission System or Distribution System (collectively the "Electrical System"), but subject at all times to any operating instructions that the Public Utility's dispatch operators may issue and in accordance with all the provisions of this Interconnection Agreement and Good Utility Practice, and any other conditions imposed by the Public Utility in its sole discretion.

Community Solar Project Operation Shall Not Adversely Affect the Public Utility's Distribution System. Interconnection Customer shall operate the Community Solar Project in such a manner as not to adversely affect the Public Utility's Distribution System or any other element of the Public Utility's electrical system. Interconnection Customer's Community Solar Project shall deliver not more than the Design Capacity of 2.99 MW. Except as otherwise required by this Interconnection Agreement, Interconnection Customer shall operate the Community Solar Project in a manner compatible with the Public Utility's applicable voltage level and fluctuating voltage guidelines, titled "Facility Connection (Interconnection) Requirements for Distribution Systems (34.5 kV and below)", as it may be amended or superseded from time to time in the Public Utility's reasonable discretion, at the Point of Interconnection during all times that the Community Solar Project is connected and operating in parallel with the Public Utility's Distribution System. In its sole discretion, the Public Utility may specify rates of change in Interconnection Customer's deliveries to the Public Utility's Distribution System during any start-up of the Community Solar Project, in accordance with the above referenced policy.

Maximum Authorized Power Flow. The Community Solar Project shall not be operated in a manner that results in the flow of electric power onto the Public Utility's Distribution System during any fifteen (15) minute interval at levels in excess of 2990kVA from the Community Solar Project. If this provision is



## Interconnection Agreement for a Community Solar Project

violated, the Public Utility may terminate this Interconnection Agreement or lock the Interconnection Customer Disconnect Switch in the open position until such time as: (a) the Public Utility has studied the impact of additional generation on the Distribution System (at Interconnection Customer's cost and pursuant to a new study agreement between the Public Utility and Interconnection Customer) and the interconnection has been upgraded (at Interconnection Customer's cost and pursuant to a new or amended Facilities Construction Agreement and a new or amended Interconnection Agreement as deemed necessary by the Public Utility) in any manner necessary to accommodate the additional generation; or (b) the Interconnection Customer has modified the Community Solar Project or Interconnection Customer's Interconnection Facilities in such manner as to insure to the Public Utility's satisfaction that the Community Solar Project will no longer cause electric power to flow onto the Public Utility's Distribution System at a level in excess of 2990kVA.

Harmonic Distortion or Voltage Flicker. Notwithstanding the study results, upon notice from the Public Utility that operation of the Community Solar Project is producing unacceptable harmonic distortions or voltage flicker on the Public Utility's Distribution System, Interconnection Customer shall at its sole cost remedy such harmonic distortions or voltage flicker within a reasonable time in accordance with Policy 138.

Reactive Power. Interconnection Customer shall at all times control the flow of reactive power between the Community Solar Project and the Public Utility's Distribution System within limits established in Policy 138. There shall be no obligation to pay for any Kvar or Kvar Hours flowing between Parties under terms of this agreement.

Islanding. If at any time during the term of this Interconnection Agreement the interconnection of the Community Solar Project to the Public Utility's Distribution System results in a risk of electrical islanding, or actual occurrences of electrical islanding, which the Public Utility reasonably concludes are incompatible with Good Utility Practice, the Parties shall (as necessary) study the issue and implement a solution that will eliminate or mitigate the risk of electrical islanding to a level deemed acceptable by the Public Utility. All costs associated with addressing any electrical islanding problems as required by this paragraph shall be paid by the Interconnection Customer, including without limitation any study costs, engineering costs, design costs, or costs to procure, install, operate and/or maintain required interconnection facilities or protective devices.

Voltage Regulation and Power Factor. The Interconnection Customer agrees to operate at unity power factor, but shall have the ability to operate at a 95% leading or lagging power factor in accordance with Policy 138. Prior to installation, Interconnection Customer shall provide the Public Utility with written notice of the device and/or operational constraints selected to satisfy this requirement and shall obtain the Public Utility's written approval of such device and/or operational constraints, which approval shall not be unreasonably withheld. In the event Interconnection Customer fails to operate the Community Solar Project within the voltage regulation constraints of Policy 138, the Public Utility may disconnect the Community Solar Project.



## Interconnection Agreement for a Community Solar Project

Modification of Nominal Operating Voltage Level. By providing Interconnection Customer with a one hundred and eighty (180) day notice, the Public Utility may at its sole discretion change the Public Utility's nominal operating voltage level at the Point of Interconnection. In the event of such change in voltage level Interconnection Customer shall, at Interconnection Customer's sole expense, modify Interconnection Customer's Interconnection Facilities as necessary to accommodate the modified nominal operating voltage level. Interconnection Customer has been informed that initial use of a dual voltage Interconnection Customer may ameliorate the cost of accommodating a change in nominal operating voltage level.

Equipment Failure. Interconnection Customer acknowledges that it is responsible for repair or replacement of Interconnection Customer's primary transformer and for any and all other components of the Community Solar Project and the Interconnection Customer's Interconnection Facilities. Interconnection Customer is aware that its inability to timely repair or replace its transformer or any other component of the Community Solar Project or Interconnection Customer's Interconnection Facility could result in Interconnection Customer's inability to comply with its responsibilities under this Interconnection Agreement and could lead to disconnection of the Community Solar Project from the Public Utility's Distribution System and/or termination of this Interconnection Agreement pursuant to the terms of this Interconnection Agreement. Interconnection Customer acknowledges that the risk of this result is born solely by Interconnection Customer and may be substantially ameliorated by Interconnection Customer's elective maintenance of adequate reserve or spare components including but not limited to the Interconnection Customer's primary transformer.

Operation and Maintenance of Facilities Not Owned by the Public Utility. Interconnection Customer shall maintain, test, repair, keep accounts current on, or provide for the proper operation of any and all interconnection facilities, including but not limited to telemetry and communication equipment, not owned by the Public Utility.

Metering and Telemetry Communications Equipment. Notwithstanding any language of the CSP Interconnection Procedures, Public Utility shall not require Interconnection Customer to install a redundant or back-up meter or other telemetry communications equipment. However, Public Utility reserves the right to request that the Oregon Public Utility Commission authorize Public Utility to require Interconnection Customer to be responsible for all reasonable costs associated with redundant metering and communications equipment installed at the Community Solar Project, upon a determination by Public Utility that such equipment is necessary to maintain compliance with the mandatory reliability standards enforced by the North American Electric Reliability Corporation and the Western Electricity Coordinating Council.

Property Requirements. Interconnection Customer is required to obtain for the benefit of Public Utility at Interconnection Customer's sole cost and expense all real property rights, including but not limited to fee ownership, easements and/or rights of way, as applicable, for Public Utility owned Facilities using Public Utility's standard forms. Public Utility shall not be obligated to accept any such real property right that does not, at Public Utility's sole discretion, confer sufficient rights to access, operate, construct, modify,



## Interconnection Agreement for a Community Solar Project

maintain, place and remove Public Utility owned facilities or is otherwise not conveyed using Public Utility's standard forms. Further, all real property on which Public Utility's Facilities are to be located must be environmentally, physically and operationally acceptable to the Public Utility at its sole discretion. Interconnection Customer is responsible for obtaining all permits required by all relevant jurisdictions for the project, including but not limited to, conditional use permits and construction permits; provided however, Public Utility shall obtain, at Interconnection Customer's cost and schedule risk, the permits necessary to construct Public Utility's Facilities that are to be located on real property currently owned or held in fee or right by Public Utility. Except as expressly waived in writing by an authorized officer of Public Utility, all of the foregoing permits and real property rights (conferring rights on real property that is environmentally, physically and operationally acceptable to Public Utility) shall be acquired as provided herein as a condition to Public Utility's contractual obligation to construct or take possession of facilities to be owned by the Public Utility under this Agreement. Public Utility shall have no liability for any project delays or cost overruns caused by delays in acquiring any of the foregoing permits and/or real property rights, whether such delay results from the failure to obtain such permits or rights or the failure of such permits or rights to meet the requirements set forth herein. Further, any completion dates, if any, set forth herein with regard to Public Utility's obligations shall be equitably extended based on the length and impact of any such delays.

Relay and Control Settings. Interconnection Customer must allow the Public Utility to hold all Level 2 relay passwords for any control and/or protective device within their control at the Point of Interconnection and/or Community Solar Project which directly impacts the Public Utility's electrical system. Level 2 passwords are those which allow actual modifications to control and/or relay settings. This will ensure the Public Utility is aware of and approves any changes being made by the Interconnection Customer. Furthermore; this will ensure there are no negative impacts to the Public Utility's Electrical System or other existing customers. Should the Interconnection Customer require modification to the settings associated with control/protective devices connected to the Electrical System the Interconnection Customer will contact the Public Utility and provide in writing the justification and/or need for the proposed modification(s). This will allow the Public Utility time to analyze and ensure there are no negative impacts to the associated connected systems and customers. The Public Utility shall review any such request, respond in writing with acceptance or, if denied, the reasons for said denial. If accepted, the Public Utility shall release to the Interconnection Customer the required password(s) so that the Interconnection Customer may affect the agreed-upon changes. The Interconnection Customer shall notify the Public Utility when the changes are placed into effect. Any modifications of control and/or relay settings without review and acknowledgement of acceptance by Public Utility will be considered a breach of Interconnect Agreement and will lead to disconnection from the Public Utility's system.



## Interconnection Agreement for a Community Solar Project

### Attachment 5

#### Public Utility' s Description of its Upgrades and Best Estimate of Upgrade Costs

**Distribution Upgrades:** Install two sets of fuses and replace two new fuses and replace 2,100' of conductor.

**System Upgrades:** The following locations will require the System Upgrades described below:

- Install line relays, install three (3) 69 kV voltage transformers and install a single 12.5 kV voltage transformer at Buckaroo substation

Estimated cost is \$321,000.





## Interconnection Agreement for a Community Solar Project

### Attachment 6

#### Scope of Work

#### Community Solar Project Modifications

The following outlines the design, procurement, construction, installation, and ownership of equipment at the Applicant's Community Solar Project.

##### *APPLICANT TO BE RESPONSIBLE FOR*

- Design, construct, own and maintain the Applicant's generating facility and associated collector system.
- Operate the Community Solar Project under constant power factor mode with a unity power factor setting unless specifically requested otherwise by the Public Utility. The Community Solar Project is expressly forbidden from actively participating in voltage regulation of the Public Utilities system without written request or authorization from the Public Utility. The Community Solar Project shall have sufficient reactive capacity to enable the delivery of 100 percent of the plant output to the POI at unity power factor measured at 1.0 per unit voltage under steady state conditions.
- Operate the Community Solar Project so minimum power quality requirements in PacifiCorp's Engineering Handbook section 1C are met, the standards are available at <https://www.pacificpower.net/about/power-quality-standards.html>. Requirements specified in the System Impact Study that exceed requirements in the Engineering Handbook section 1C power quality standards shall apply.
- As per NERC standard VAR-001-1, the Public Utility is required to specify voltage or reactive power schedule at the Point of interconnection. Under normal conditions, the Public Utility's system should not supply reactive power to the Community Solar Project.
- Install a transformer that will hold the phase to neutral voltages within limits when the Community Solar Project is isolated with the Public Utility's local system until the generation disconnects.
- Design, procure, install, and own a Public Utility approved 12.47 kV recloser containing a Schweitzer Engineering Laboratories ("SEL") 651R relay/controller to perform the following functions:
  - Detect faults on the 12.47 kV line and equipment at the Community Solar Generation Project
  - Detect faults on the 12.47 kV line to Buckaroo Substation
  - Monitor the unbalance current flowing through the grounding transformer and protect the transformer from damage due to phase unbalances on the 12.47 kV circuit
  - Monitor the voltage and react to under or over frequency, and /or magnitude of the voltage
  - Receive transfer trip from Buckaroo Substation



## Interconnection Agreement for a Community Solar Project

- Procure and install instrument transformers or voltage sensors on the Public Utility side of the recloser.
- Input the settings provided by the Public Utility into the recloser relay.
- Provide the Public Utility Level 2 password control of the recloser relay.
- Terminate the control cable provided by the Public Utility in the recloser relay.
- Provide the Public Utility the necessary easement to allow the Public Utility to construct its line extension between its existing facilities and the Point of Change of Ownership.
- Provide Public Utility unfettered and maintained access to its interconnection facilities.
- Construct the Applicant's last pole at the Point of Change of Ownership to Public Utility's standard.
- Arrange for and provide permanent retail service for power that will flow from the Public Utility's system when the Project is not generating. Applicant shall coordinate with the Public Utility's customer service group establish a request number and account number.
- Provide any construction or backup retail service necessary for the Project.
- Provide the Public Utility a Professional Engineer ("PE") stamped maintenance plan for all Applicant protective equipment.

### ***PUBLIC UTILITY TO BE RESPONSIBLE FOR***

- Coordinate with the Applicant to establish request and account numbers.
- Develop and provide overcurrent, voltage and frequency settings for the Applicant's recloser relay.
- Observe and provide acceptance of the relay settings in the Applicant's recloser relay.
- Observe and provide acceptance of the installation of the Applicant's final pole at the point of change of ownership.
- Terminate the final span of conductor onto the Applicant's final pole.
- Provide the Applicant control cable for Applicant to terminate to its recloser relay. Observe the installation and confirm connectivity and functionality of the transfer trip communications path.

### **Point of Interconnection**

The following outlines the design, procurement, construction, installation, and ownership of equipment at the Point of Interconnection.

### ***PUBLIC UTILITY TO BE RESPONSIBLE FOR***

- Design, procure, install, own and maintain at the Applicant's expense the required extension of the 12.47 kV facilities from Public Utility's existing facilities to the point of change of ownership including a minimum of two poles, conductor, cutouts, fuses, jumpers and a gang operated switch.
- Install an approximately 30' wood pole and spread spectrum radio equipment. The radio will be designed to establish a link with the Public Utility's Buckaroo substation.
- Provide the Interconnection Customer cable from its radio to the Interconnection Customer recloser.



## Interconnection Agreement for a Community Solar Project

- Design, procure and install 12.47 kV revenue metering equipment for the Project including a revenue quality meter and instrument transformers.
- Provide and install a cellular connection for retail sales and generation accounting via the MV-90 translation system.

### Other

The following outlines the design, procurement, construction, installation, and ownership of equipment past the Point of Interconnection.

#### *PUBLIC UTILITY TO BE RESPONSIBLE FOR*

- Distribution Circuit
  - Replace two sets of existing fuses upstream of the POI and install new fuses on the two existing taps off the proposed route to the POI.
  - Remove approximately 1,100' for existing three, two and single phase conductor between transmission structures 10/7 and 12/7.
  - Install approximately 2,100' of new conductor between transmission structures 8/7 and 12/7.
  - Replace any of the transmission structures deemed as required during detailed design.
- Buckaroo Substation
  - Procure and install line relays to detect faults on the 69 kV line that feeds the substation.
  - Procure and install three 69 kV voltage transformers.
  - Procure and install a 12.5 kV voltage transformer on the low side of circuit breaker 5W202.
  - Install a dead line check control circuit on circuit breaker 5W202
  - Develop and implement a transfer trip scheme to disconnect the Interconnection Customer's Community Solar Project for the following:
    - Faults on circuit 5W202
    - Faults in the 69 – 12.47 kV transformers
    - Faults on the 69 kV lines to which Buckaroo substation is connected
  - Install an antenna on the existing microwave tower that will link to the radio system at the POI. Install supportive communications equipment to support the transfer trip scheme.



**Interconnection Agreement for a Community Solar Project**

**Attachment 7**

**Facility Connection (Interconnection) Requirements for Distribution Systems (34.5 kV and below)  
(attached)**

## AGREEMENT TO AMEND INTERCONNECTION AGREEMENT FOR A COMMUNITY SOLAR PROJECT

This **Agreement To Amend Interconnection Agreement for a Community Solar Project** (“Agreement”) is made and entered into this 22nd day of May, 2023, by and between PacifiCorp, an Oregon corporation (the “Public Utility”) and Buckaroo Solar 2, LLC (OCS063), an Oregon limited liability company (the “Interconnection Customer” or “Applicant”). Public Utility and Interconnection Customer may be referred to as a “Party” or collectively as the “Parties.”

### RECITALS

**WHEREAS**, Public Utility and Interconnection Customer have entered into an Interconnection Agreement for a Community Solar Project (“Interconnection Agreement”), dated September 30, 2022, ;

**WHEREAS**, Public Utility and Interconnection Customer have mutually agreed to amend one or more attachments to the Interconnection Agreement; and

**WHEREAS**, Article 8.2 of the Interconnection Agreement states that the Parties may mutually agree to amend this Interconnection Agreement by a written instrument duly executed by both parties;

**NOW, THEREFORE**, in consideration of and subject to the mutual covenants contained herein, it is agreed:

- 1.0 The Parties acknowledge and mutually agree that the following attached attachment will substitute in its entirety the same attachment in the Interconnection Agreement:   
  - Attachment 3
- 2.0 Service under the Interconnection Agreement with the amended attachment will commence only upon execution by both Parties.
- 3.0 The Interconnection Agreement, with the attached substitute attachment shall constitute the entire agreement between the Parties.
- 4.0 All other provisions of the Interconnection Agreement will continue to apply.

**IN WITNESS WHEREOF**, the Parties have executed this Agreement in duplicate originals, each of which shall constitute and be an original effective Agreement between the Parties.

**PacifiCorp**

**By:** Kristopher J Bremer  
Kristopher J Bremer  
2023.05.22 19:11:19  
-07'00'

**Title:** Dir., Transmission Svcs

**Date:** 05/22/2023

**Buckaroo Solar 2, LLC (OCS063)**

**By:** D Hale

**Title:** Managing Member

**Date:** 5/5/23



## Interconnection Agreement for a Community Solar Project

### Attachment 3

#### Milestones

Estimated In-Service Date: September 30, 2025

Critical milestones and responsibility as agreed to by the Parties:

<b>Milestone/Date</b>	<b>Responsible Party</b>
<u>Execute Interconnection Agreement</u> September 2, 2022 - completed	<u>Applicant</u>
<u>Provision of First Progress Payment</u> September 2, 2022 - completed	<u>Applicant</u>
<u>Applicant and Public Utility Establish Retail Service Request</u> January 15, 2024	<u>Both</u>
<u>*Applicant Initial Design Package Provided</u> January 15, 2024	<u>Applicant</u>
<u>Public Utility Engineering &amp; Procurement Commences</u> March 4, 2024	<u>Public Utility</u>
<u>Applicant Property/Permits/ROW Procured</u> May 6, 2024	<u>Applicant</u>
<u>Public Utility Property/Permits/ROW Procured</u> October 2, 2024	<u>Public Utility</u>
<u>*Applicant Final Design Package Provided</u> October 3, 2024	<u>Applicant</u>
<u>Public Utility Engineering Design Complete</u> November 11, 2024	<u>Public Utility</u>
<u>Construction Begins</u> January 2, 2025	<u>Public Utility</u>
<u>Applicant Maintenance and Commissioning Plans Provided</u> August 7, 2025	<u>Applicant</u>
<u>Applicant and Public Utility Construction Complete</u>	<u>Both</u>



## Interconnection Agreement for a Community Solar Project

September 5, 2025

<u>Public Utility Commissioning Activities Complete</u>	<u>Public Utility</u>
September 19, 2025	

<u>Public Utility Commissioning Document Review Complete</u>	<u>Public Utility</u>
September 21, 2025	

<u>Applicant’s Facilities Receive Backfeed Power</u>	<u>Applicant</u>
September 22, 2025	

<u>Initial Synchronization/Generation Testing</u>	<u>Applicant</u>
September 24, 2025	

<u>Commercial Operation</u>	<u>Applicant</u>
September 30, 2025	

Interconnection Customer is to request Backfeed, 1<sup>st</sup> Sync, and Commercial Operations in writing (email acceptable) prior to the above dates. Public Utility is to approve Interconnection Customer requests without unreasonable delay. The Interconnection Customer will be required to demonstrate the reactive capability of the Community Solar Project and the voltage control system prior to Commercial Operations.

\* Any design modifications to the Interconnection Customer’s Community Solar Project after this date requiring updates to the Public Utility’s network model will result in a minimum of 3 months added to all future milestones including Commercial Operations.

**Payment Schedule\***

If Interconnection Customer agrees to progress payments option under Article 4.6 of the Interconnection Agreement, there are two potential options for a payment schedule below (please select one). If Interconnection Customer elects progress payment option but an option below is not selected, the Levelized Option will be selected by default. Failure to comply with the selected payment schedule will result in contractual breach, work stoppage, and slip of the milestone schedule above on a day-for-day basis. Interconnection Customer will still be responsible for all costs of the project. Public Utility will conduct initial accounting for the project within thirty (30) days of granting Commercial Operations approval and will determine if a partial refund of project costs is acceptable.

Please select an option:	<input type="checkbox"/>	<input type="checkbox"/>
<u>Funds due no later than</u>	<u>Levelized Option</u>	<u>Stepped Option</u>
September 2, 2022		
(or when Interconnection Agreement is executed)	\$10,000	\$10,000 – paid
January 2, 2024	\$118,000	\$47,200





## Interconnection Agreement for a Community Solar Project

July 2, 2024	\$118,000	\$94,400
September 2, 2024	\$118,000	\$141,600
December 2, 2024	\$118,000	\$188,800

\*Please see Attachments 5 and 6 for further information as estimated costs may change during detailed engineering.



# CITY OF PILOT ROCK

P.O. BOX 130 • 144 N. ALDER PLACE • PILOT ROCK, OREGON 97868  
OFFICE: 541-443-2811 • FAX: 541-443-2254

11/30/2023

PacificCorp  
Attn: Kris Bremer  
825 NE Multnomah Street  
Portland, OR 97232

**RE: Pilot Rock Industrial Land Infrastructure Planning**

Dear Kris,

We are reaching out to share our effort and vision in developing 440Ac of Industrial Zoned land in the City of Pilot Rock, Oregon. This parcel was deeded to us by International Paper in the 1980's and is one of the largest, industrial areas actively zoned and marketed in Eastern Oregon. The contiguous parcel is near and served by your Pilot Rock Substation.

After DEQ clearances, we have recently expanded local, regional, and statewide marketing of the property through our municipal website, and Business Oregon which is the state's economic development agency. Promotion of the property includes the designation of the Pendleton-Pilot Rock Enterprise Zone to attract business incentives for new parcel sales and lease end users that invest capital creating benefit that provide employment measures.

We ask that PacifiCorp to be aware of, actively plan for and accommodate Industrial-type service for this land. We have invested in a survey plat and deed restrictive 80ft wide utility and road easement from Circle Rd, north ~2000LF into the interior of the parcel. The easement focuses essential lot services for existing 6in gas main by Cascade Gas, City's sewer main, and near-term City water main line. For obvious reasons, we desire a single pole line adjacent to this infrastructure. Our zoning code allows for a wide range of uses that would use services at 480V, 12.7kV or more as available.

Steve Draper, Public Works Director, met Doug Treibelhorn at the easement and discussed the landholding, easement, and pole placement for one long-term lessor. The adjacent parcel to this area was sold for use as a construction and fire equipment refurbishing shop with other interest West and North of the easement ongoing.

Electrical service is essential to our vision to develop this area. Your assistance in infrastructure planning for this area's development is greatly appreciated.

Sincerely,

A handwritten signature in blue ink that reads "Randy Gawith". The signature is written in a cursive, flowing style.

Randy Gawith  
Mayor



CITY OF PENDLETON  
ECONOMIC DEVELOPMENT

PacifiCorp  
Attn: Kris Bremer  
825 NE Multnomah Street  
Portland, OR 97232

December 1, 2023

*RE: Pilot Rock Industrial Land Infrastructure Planning*

To Whom It May Concern:

The City of Pendleton strongly supports Pilot Rock's effort and vision in developing 440 acres of Industrially-zoned land in the City of Pilot Rock, Oregon. The importance of getting electrical service to the subject property cannot be overstated.

For over 10 years, I have served as the Enterprise Zone Manager for the Pendleton-Pilot Rock Enterprise Zone. Enterprise Zone tax abatement is Oregon's best incentive to attract new industry to the state and help existing industry to expand operations here. However, contrary to popular belief, "incentives" are only the 5<sup>th</sup> most important factor that companies and site selectors look for. The other four factors that rank above incentives in importance are available workforce, transportation costs, existing buildings and one of the most critical—available, properly-zoned land *with infrastructure*. That importance of that 4<sup>th</sup> factor cannot be overstated, and the importance of the infrastructure being on or very close to the land cannot be underestimated. Shovel-ready ground is property that is ready to be built upon with utilities to the edge of the property. Anything less than that represents tremendous risk to a developer, and more often than not, ground that is not shovel-ready will not be taken seriously as an option for development.

The City of Pendleton strongly supports Pilot Rock's need to get all services to the edge of the subject property. Whatever PacifiCorp can do to facilitate making this property shovel-ready would be very much appreciated. Please do not hesitate to call or email with questions.

Sincerely,

A handwritten signature in blue ink, appearing to read "S. Chrisman", with a horizontal line extending to the right.

Steven B. Chrisman  
Economic Development & Airport Director  
City of Pendleton



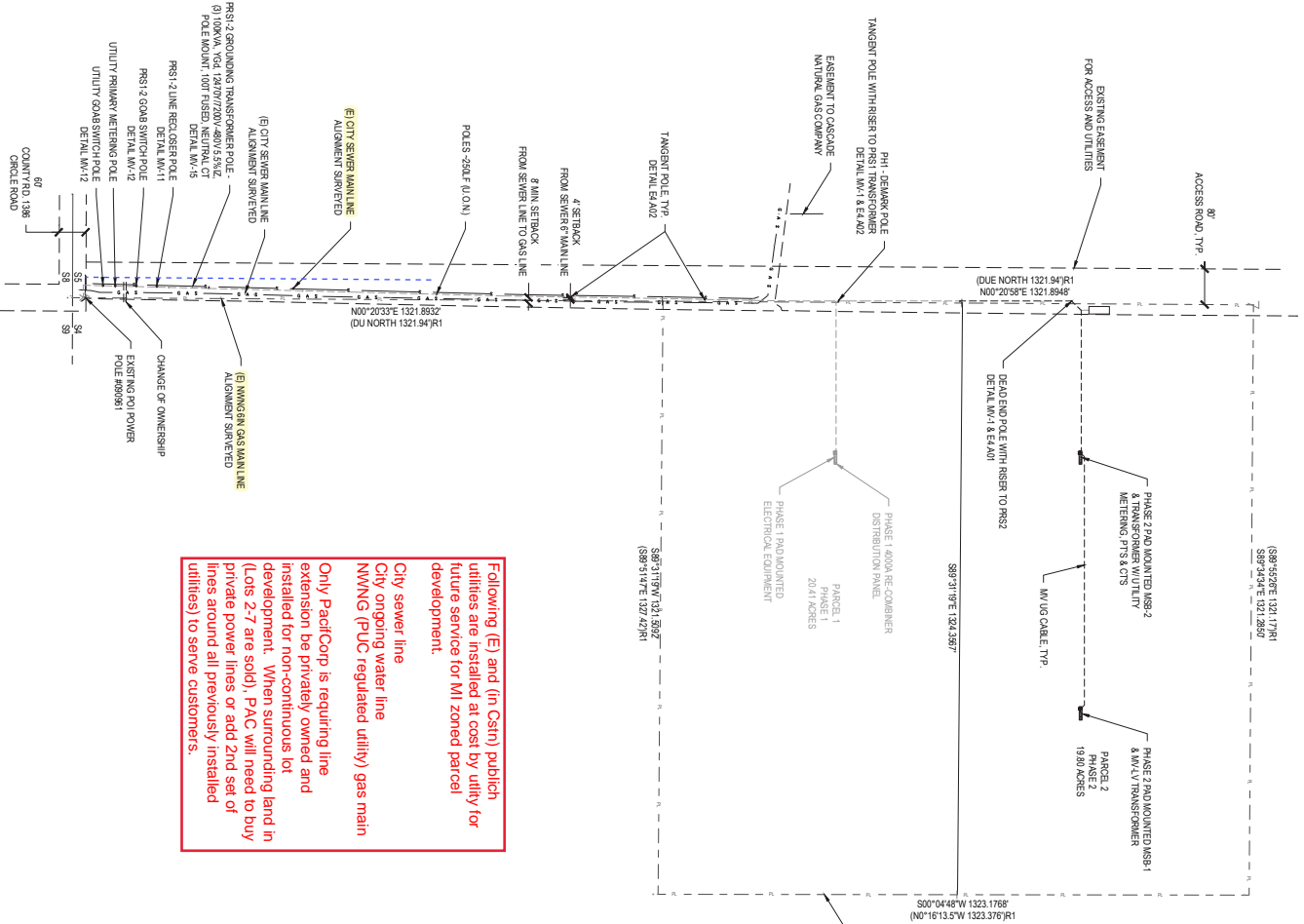

Following (E) and (in Grn) public utilities are installed at cost by utility for future service for MI zoned parcel development.

City sewer line  
City originating water line  
NWNNG (PUC regulated utility) gas main

Only PacifiCorp is requiring line extension be privately owned and installed for non-continuous lot development. When surrounding land in (Lots 2-7 are sold), PAC will need to buy private power lines or add 2nd set of lines around all previously installed utilities to serve customers.

REV	ISSUED BY	DESCRIPTION
07/06/23	PK	PHASE 2 - PERMIT SET

SCALE: 1/128" = 1'-0"

ORIGINAL SIZE 24" x 36"

SHEET NUMBER: 0

TOTAL SHEETS: 1

DATE: 7/6/2023

PROJECT: 4554kW DC SOLAR ELECTRIC SYSTEM PILOT ROCK - PHASE 2

PROJECT NUMBER: 16-01

4554kW DC SOLAR ELECTRIC SYSTEM  
PILOT ROCK - PHASE 2  
PILOT ROCK, OR 97868  
PROJECT NUMBER: 16-01

Southwest Energy, LLC

PO BOX 49  
STANFELD, OR 97132  
310375-4732  
DANIEL GIBSON  
@SWE/THL  
20195

Attachment E/Page 2

November 29, 2023

**VIA ELECTRONIC MAIL (Kristopher.Bremer@PacifiCorp.com)**

Mr. Kristopher Bremer  
Director, Generation Interconnection  
PacifiCorp  
825 NE Multnomah, Suite 1600  
Portland OR 97232

Subject: **Docket UM 2177—Second Amended Notice of Intent to file Complaint of Enforcement**  
Q0666--Sunthurst Energy, LLC--Pilot Rock Solar 1, LLC  
Q1045--Sunthurst Energy, LLC--Pilot Rock Solar 2, LLC  
OCS024--Sunthurst Energy, LLC--Tutuilla Solar, LLC

Dear Mr. Bremer,

As you know, Oregon’s Community Solar Program has grossly underperformed expectations. In the November 14 Docket UM 1930 Workshop, PacifiCorp reported that only 6 Community Solar Projects (CSPs), totaling 2.464 MW out of its 65 MW Initial Program Capacity, have reached operation. Failure to realize the Initial Program Capacity would be a broken promise to its many subscribers, a disaster to developers who answered the State’s call for community solar, and a black mark on state policymakers. Sunthurst Energy, LLC (Sunthurst), a small, family owned, business, was one of the first developers to commit to building Community Solar Projects and has spent hundreds of thousands of dollars on its CSPs. Sunthurst’s five pre-Certified CSPs<sup>1</sup>, all located in PacifiCorp territory, embody the policy objectives of the Community Solar Program. The projects are subscribed by PacifiCorp’s low-income customers and state agencies seeking to lower their carbon footprint. Tutuilla Solar, LLC (Tutuilla) is the only CSP sponsored by an Indian tribe (the Confederated Tribes of the Umatilla Indian Reservation, or “CTUIR”) and located on tribal land. Pilot Rock Solar 1, LLC (Pilot Rock 1) and Pilot Rock Solar 2, LLC (Pilot Rock 2) are sited in City of Pilot Rock, a recognized Economically Distressed Area. Pilot Rock 1 received a substantial state RED grant, and Tutuilla received a large CREP grant. **For the good of the Oregon Community Solar Program and its stakeholders, these Projects must not fail.**

To develop its CSPs, Sunthurst has overcome numerous obstacles. In 2020, PacifiCorp’s overpriced interconnection costs necessitated litigation which delayed Sunthurst’s timeline 14 months.<sup>2</sup> In 2022, PacifiCorp wrongly refused to process Sunthurst’s PPA requests until Sunthurst completed its interconnection agreements.<sup>3</sup> This delay, which occurred while interest rates were rising rapidly,

---

<sup>1</sup> Pilot Rock Solar 1, LLC (PRS1, 1.98 MW, Q0666); Pilot Rock Solar 2, LLC (PRS2, 2.99 MW, Q1045); Tutuilla Solar, LLC (Tutuilla, 1.56 MW, OCS 024); Buckaroo 1 Solar, LLC (Buckaroo 1, 2.4 MW, OCS 062); Buckaroo 2 Solar, LLC (Buckaroo 2, 2.99 MW, OCS 063).

<sup>2</sup> See Docket UM 2118 (PacifiCorp interconnection charges for PRS1, PRS2 and Tutuilla were reduced, from \$2.14M in the initial Facilities Studies to \$1.15M in the Interconnection Agreements).

<sup>3</sup> The Commission banned this practice in 2007, when it ordered PacifiCorp to remove from its Schedule 38 the requirement of a completed interconnection study. Order 07-360, p. 8, ORE PUC LEXIS 279, \*16 (August 20, 2007). Conditioning a PURPA PPA on a final interconnection agreement likely violates PURPA (*See FLS Energy, Inc.* 157 F.E.R.C. P61,211, 61730, 2016 FERC LEXIS 2167, \*17-18 (F.E.R.C. December 15, 2016) (“requiring a QF to tender an executed interconnection agreement [to have a legally enforceable obligation] is equally inconsistent with PURPA and our regulations”). It also fell short of this Commission’s order, in *Dalreed Solar, LLC v.*

Mr. Kristopher Bremer

November 29, 2023

Page 2

prevented Sunthurst from closing on financing for 13 months. Had PacifiCorp not withheld the PPAs, the three Sunthurst Projects would already be built. When Sunthurst asked for a 13-month extension in the CODs due to delays in financing, PacifiCorp extended the CODs by 28 months instead, and required Sunthurst to prepay all construction costs 455 days prior to Commercial Operation. Most recently, on October 18, October 31, November 7 and November 17, when Sunthurst informed PacifiCorp of its urgent need to accelerate Project completion dates in the Interconnection Agreements for the Three Projects, PacifiCorp waited 30 days before providing a hurriedly prepared response, requiring minimal effort, which could have been provided weeks prior.

PacifiCorp's slow, vague response has jeopardized Sunthurst's RED grant, which has a looming sunset, and also its current private construction financing package. PacifiCorp's denial of PPAs violated federal law and state policy. PacifiCorp's long completion times and excessive pre-payment requirements are unreasonable and discriminatory, and its interconnection costs are excessive. PacifiCorp's actions have financially damaged Sunthurst. Together, the pattern of behavior above is strong evidence of animus towards Community Solar Projects, and the competition to PacifiCorp's monopoly they represent.

**By this letter, Sunthurst gives notice of its intent to file a Complaint with the Public Utility Commission of Oregon ("Commission") pursuant to OAR 860-082-0085<sup>4</sup> ten days from the date above**, arising from PacifiCorp's unreasonable terms of its interconnection agreement for Pilot Rock Solar 1, Pilot Rock Solar 2, and Tutuilla Solar projects; PacifiCorp's wrongful refusal to negotiate Power Purchase Agreements; PacifiCorp's failure to timely respond to Sunthurst communications; and PacifiCorp's anti-competitive conduct. Sunthurst may seek penalties, injunctive relief, declaratory relief, and monetary damages before the Commission and/or state court.

The alleged violations are very serious. Nevertheless, they may be resolved without litigation provided PacifiCorp engages cooperatively in developing workable timelines and construction payment terms. At a workshop held November 14 in Docket UM 1930, PacifiCorp assured the Commission that it would work with developers to meet their scheduling needs. Sunthurst is receptive to such cooperation.

**Issues Requiring Resolution.** The following issues require urgent attention:

**1. The September 30, 2025 Commercial Operation Date in the current IAs is unreasonably long.**

PacifiCorp interconnection timelines have steadily increased since the advent of the Community Solar Program. In early 2022, PacifiCorp committed to build the Pilot Rock Solar 1 and 2 interconnections in 60 days. Later that year, PacifiCorp increased the construction window to 90 days. But in 2023, PacifiCorp revised the timeline for the same scope of work, to 240 days. Similar enlargements occurred at Sunthurst's Tutuilla Solar Project:

<b>Pilot Rock Solar 1 and 2 IA Amendment Date:</b>	<u>3/17/22</u>	<u>8/15/22</u>	<u>5/22/23</u>
Scheduled Construction Duration:	<b>60 days</b>	<b>90 days</b>	<b>240 days</b>
Scheduled COD:	12/31/22	5/25/23	9/30/25

**Table 1.** How PacifiCorp construction timelines have increased over time.

A reasonable construction duration for both Pilot Rock Projects (as shown by the previous IA schedule) is 90 days. Longer duration schedules increase costs and delay completion without good cause. By reverting to the 90-day construction window in its previous IA, Pilot Rock Solar 1 and 2 could be accelerated by

*PacifiCorp*, Docket UM 2125, Order 21-097, p. 7 ("Accordingly, we expect PacifiCorp to continue with its new policy of offering draft PPAs prior to the completion of interconnection studies for non-standard contracts.").

<sup>4</sup> Sunthurst may also use the contested case process, OAR 860-001-0000, et seq, per OAR 860-088-0110(b).

Mr. Kristopher Bremer  
 November 29, 2023  
 Page 3

150 days, or five months. The Pilot Rock 1 schedule also assumes a November 11, 2024 final engineering design milestone. In fact, PacifiCorp largely completed final engineering prior to 2020. This milestone could be accelerated to early 2024 because the amount of remaining work is small. Pilot Rock Solar 2 engineering could also be shortened, because its scope is much smaller than the scope for Pilot Rock Solar 1. By reverting the construction schedule, shortening the engineering timeline, and removing several months of scheduled float time, the commercial operation date for Pilot Rock Solar 1 and 2 can be moved well inside of 2024. Sunthurst requests the earliest possible 2024 COD for Pilot Rock Solar 1 and 2, with Tutuilla COD occurring 60 days thereafter.

**2. Sunthurst is not preventing PacifiCorp from revising the construction timelines.**

In your November 17 e-mail, you requested more information so that PacifiCorp can substantively respond to Sunthurst’s requested schedule revision. Sunthurst previously submitted the requested information to PacifiCorp, as explained below:

**Bremer Request #1:** “Sunthurst will need to call PacifiCorp's customer service group and request a new retail service at the location of the Pilot Rock and Tutuilla sites.”

**Sunthurst Response:** Sunthurst submitted retail service requests for Pilot Rock 1, Pilot Rock Solar 2 and Tutuilla Community Solar Projects, on March 17, 2022, and notified PacifiCorp Transmission through its attorney, Nate Larsen, the same day. Sunthurst has already complied with this request. A copy of the retail service request is attached.

**Bremer Request #2:** “Sunthurst will need to provide it's initial, proposed layout of the three solar facilities, perform a site visit with PacifiCorp personnel and confirm inverter selections.”

**Sunthurst Response:** Sunthurst submitted its initial, proposed layout for Pilot Rock 1, Pilot Rock Solar 2 and Tutuilla Community Solar Projects, on March 17, 2022 through PacifiCorp Transmission attorney, Nate Larsen. On November 17, 2023, Sunthurst supplemented the March 17, 2022 submittals with stamped one-line drawings of the three Projects. Further, PacifiCorp’s local estimator, Doug Triebelhorn, visited the Pilot Rock 1 and 2 sites in spring 2022.

Sunthurst believes PacifiCorp has all the information it needs to move forward with design and procurement. If PacifiCorp reasonably requires additional information, Sunthurst will provide.

**3. PacifiCorp’s prepayment requirements in the IA are unreasonable.**

PacifiCorp’s May 22, 2023 amended IAs contain accelerated new prepayment requirements, which, combined with current high interest rates, create another high obstacle for CSP developers. Under the original Interconnection Agreements, PacifiCorp required full payment 85 days prior to the COD. Under the May 22 amendments, PacifiCorp required full payment 455 days prior to the COD—a 370-day acceleration compared to the prior interconnection agreements. This is 180 days before PacifiCorp plans to commence construction.

Project	Scheduled COD, Current PPA:	Date of final prepayment, Current PPA:	# of Days payment due before COD, current IA:	# of Days payment due before COD, prior IA:	Prepayment acceleration:
PRS1	9/30/25	7/2/24	455 days	85 days	370 days
PRS2	9/30/25	7/2/24	455 days	85 days	370 days
Tutuilla	9/30/25	7/2/24	455 days	85 days	370 days

**Table 2.** Pre-payment deadlines PacifiCorp added to May 22, 2023 IA amendments.



Mr. Kristopher Bremer

November 29, 2023

Page 4

PacifiCorp's practice of requiring payment in full six months before start of construction is onerous to the Project, a windfall to PacifiCorp, and dis-incentivizes PacifiCorp to timely complete construction. The hardship caused by PacifiCorp's prepayment requirements is aggravated by another factor: Oregon's various renewable energy grants (RED grant, CREP grant) withhold substantial payment of grant funds to developer until a Project has been completed. Accordingly, developers must find a way to make the prepayments without access to state grant money.

**A. Sunthurst requests PacifiCorp accept Sunthurst's penultimate deposits prior to commencement of construction, and final payment upon Commercial Operation.** Such terms would approximate payment schedules typical of large construction projects, and would allow Sunthurst to use the state grant money released upon Commercial Operation to pay the final installment.<sup>5</sup> Such payment terms are authorized by existing Commission rule.<sup>6</sup>

**B. Alternatively, Sunthurst requests PacifiCorp pay for or delete unnecessary upgrades.** The OARs and the interconnection agreements only require the interconnection customer to pay for reasonable costs that are necessary to safely interconnect the small generator. Recently, several of PacifiCorp's interconnection practices were called into question, in Docket AR 659:

i. *DC, not AC, capacity.* Historically, PacifiCorp conducted facilities studies for distributed solar generators using DC, not AC, capacity ratings for the new solar and existing generators in the study.<sup>7</sup> According to recent AR 659 testimony by the Interstate Renewable Energy Council (IREC), using DC capacity overcounts the impact of each resource, potentially affecting project economics in several ways

There are many ways that failing to update existing DERs' nameplate ratings will overstate impacts on the distribution system. First, using the DC nameplate rating instead of the AC nameplate rating for existing DERs likely causes the utilities to prematurely designate a feeder as a "limited generation," which prevents additional DER from interconnecting without an expensive and time-consuming study process. Second, using the DC nameplate rating instead of the AC nameplate rating for existing DERs means that utilities are likely requiring upgrades that are not necessary. Or if the upgrades would have eventually been required by a later queued DER anyway, utilities may wrongly assign the cost of the upgrade to an earlier-queued DER. Third, having databases that accurately show the size of existing DERs is a key input to a hosting capacity analyses. IREC strongly opposes utilities spending any time or resources to perform a hosting capacity analyses unless the Commission and stakeholders have confirmed that appropriate data, including AC nameplate ratings and measured load data, is input into the model. These are just three examples of why it is important for utility databases to include appropriate data, and there are surely many others. **Therefore, it is unreasonable to allow utilities to use inappropriate data in distribution system operations, distribution system planning, and the interconnection evaluation process in perpetuity.**<sup>8</sup>

---

<sup>5</sup> By way of illustration, suppose an interconnection costs \$600,000, and the project is due to receive \$250,000 from ODOE after the project is certified as completed. Instead of requiring \$600,000 payment six months before construction, PacifiCorp would bill the final installment upon certifying the Project for commercial operation, and Sunthurst would direct ODOE to pay PacifiCorp from grant funds, upon completion of the Project.

<sup>6</sup> OAR 860-029-0060 (2) provides the project shall "reimburse" (not prepay) the utility for all reasonable utility costs of interconnection. Further, OAR 860-029-0060(2) authorizes utilities to finance interconnection construction costs, and to recoup the money from the qualifying facility.

<sup>7</sup> See, OPUC Docket No. AR 659, *Joint Utilities' Opening Comments Regarding Proposed Division 39 and Division 82 Rules*, p. 5 (October 13, 2023).

<sup>8</sup> OPUC Docket No. AR 659, *Comments of the Interstate Renewable Energy Council on Proposed Revisions to the Small Generator Interconnection and Net Metering Rules*, p. 8 (November 7, 2023)(emphasis added).

Mr. Kristopher Bremer

November 29, 2023

Page 5

If Sunthurst's Projects have been saddled with upgrade requirements due to PacifiCorp using DC ratings in its models and studies, this should be corrected prior to final design and final construction. Sunthurst asks that PacifiCorp determine if Sunthurst was harmed by PacifiCorp using DC ratings, and make appropriate adjustment to redress such harm.

ii. *Direct Transfer Trip*. Another issue of concern is PacifiCorp's insistence on Direct Transfer Trip. According to IREC's November 7, 2023 testimony in Docket AR 659,

the presence of an inverter with UL 1741 certification ensures protection against adverse distribution system conditions according to industry standards. For example, any certified inverter is equipped with appropriate anti-islanding and voltage protection. Adding an export-limiting relay does not remove or disengage the inverter's anti-islanding or voltage protection functionality. The required voltage protection will cause the inverter to trip within 0.16 seconds of detecting adverse system conditions. In the vast majority of DERs, IREC expects a certified inverter to serve as the protection against adverse system conditions, so the relay would only serve to prevent export and not provide other protection functions. **The Commission should require utilities to trust that certified inverters will perform according to their design and certification standard.**

Page 12 (footnotes omitted, emphasis in original). IREC says, above, that UL 1741 certified inverters provide anti-islanding and voltage protection within 0.16 seconds, and that utilities should trust certified inverters to perform as certified. Furthermore, the Cherry Creek Solar, LLC, CSP, which installed PacifiCorp's DTT scheme, is experiencing a high level of nuisance trips, causing repeated uncompensated loss of generation and labor costs.<sup>9</sup> If PacifiCorp's current interconnection scheme still contains equipment not required by good utility practice, which is interfering with operations of a CSP, DTT should be eliminated, or paid for by PacifiCorp, to reduce cost and/or accelerate construction of interconnection facilities.

**Conclusion.** Notwithstanding the aforementioned obstacles, Sunthurst is on the cusp of closing financing for three CSPs—Pilot Rock 1, Pilot Rock Solar 2, and Tutuilla. These projects are interdependent for financing, such that failure of one project will cause all three to fail. Resolution of a workable construction and milestone payment timeline would obviate Sunthurst's need to pursue litigation. If there is room for discussion, please contact Sunthurst at your soonest convenience--in any event within 10 days, with PacifiCorp's response.

Sincerely,

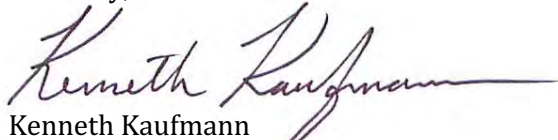

Kenneth Kaufmann

Attorney for Sunthurst Energy, LLC

Enclosure: March 17, 2022 letter to PacifiCorp requesting Retail Service

---

<sup>9</sup> See OPUC Docket No. UM 2298, July 18, 2023 *Notice of Intent to File Complaint of Enforcement*.

Mr. Kristopher Bremer

November 29, 2023

Page 6

Copy:

Matthew Loftus (e-mail)  
Senior Transmission Counsel  
PacifiCorp  
825 NE Multnomah St, Suite 1600  
Portland, OR 97232  
Matthew.Loftus@PacifiCorp.com

Filing Center (e-mail)  
Public Utility Commission of Oregon  
PO Box 1088  
Salem, OR 97308-1088  
PUC.FilingCenter@state.or.us



PacifiCorp Work Order Request Numbers

March 17, 2022

RE: PacifiCorp Work Order Numbers  
PacifiCorp Service Center No.- 800-469-3981  
Agent: Christian; ee #36734

Sunthurst Energy LLC (OR) Base Acct No. **77325300 005 5**

POI Work Order No.

Circle Rd / Pilot Rock Hoeft Rd intersection. N. 1650LF to site.

**POI Meter Work Request No. – 8181629; noted this meter paid by Company per UM2118**

PP2020-13 (aka Q0666 / Pilot Rock Solar 1)-

Pilot Rock Solar 1 **Meter Work Request No. - 8181636**

PP2020-71 (aka Q1045 / Pilot Rock Solar 2)-

Pilot Rock Solar 2 **Meter Work Request No. - 8181646**

PP2020-81 (aka OCS024 / Tutuilla Solar)-

NW Crnr of S. Market Rd & Tutuilla Church intersection. N. 1650LF to site.

Tutuilla Solar **Meter Work Request No. - 8181678**

Attachment F

CERTIFICATE OF SERVICE

In accordance with ORCP 9 and OAR 860-082-0085(2), I hereby certify that on November 29, 2023, I caused to be served a full and exact copy of the foregoing Notice of Intent to file Complaint of Enforcement via email to the following parties:

<p>Mr. Kristopher Bremer Director, Generation Interconnection PacifiCorp 825 NE Multnomah, Suite 1600 Portland OR 97232 <a href="mailto:Kristopher.Bremer@pacifiCorp.com">Kristopher.Bremer@pacifiCorp.com</a></p> <p>(service via email only)</p>	<p>Filing Center (e-mail) Public Utility Commission of Oregon PO Box 1088 Salem, OR 97308-1088 <a href="mailto:PUC.FilingCenter@state.or.us">PUC.FilingCenter@state.or.us</a></p> <p>(service via email only)</p>
<p>Matthew Loftus Senior Transmission Counsel PacifiCorp 825 NE Multnomah St, Suite 1600 Portland, OR 97232 Matthew.Loftus@pacifiCorp.com</p> <p>(service via email only)</p>	<p>Sunthurst Energy, LLC Attn: Dan Hale PO Box 549 Stanfield, OR 97875 <a href="mailto:Daniel@sunthurstenergy.com">Daniel@sunthurstenergy.com</a></p> <p>(service via email only)</p>

Dated: November 29, 2023

/s/ Kenneth Kaufmann  
Attorney for Sunthurst Energy, LLC  
OSB No. 982672

**Confederated Tribes of the  
Umatilla Indian Reservation**

Office of the Executive Director



46411 Timine Way, Pendleton, OR 97801  
(541) 429-7363 | phone/fax  
<https://ctuir.org> | [oed@ctuir.org](mailto:oed@ctuir.org)

December 28, 2023

via email  
[joseph.abraham@puc.oregon.gov](mailto:joseph.abraham@puc.oregon.gov)  
[puc.publiccomments@puc.oregon.gov](mailto:puc.publiccomments@puc.oregon.gov)

Public Utility Commission of Oregon  
201 High Street SE  
Salem, OR 97301

**RE: CTUIR Support for Renewable Energy and the Tutuilla Solar Project**

**UM 1930 & UM 2177**

Dear Public Utilities Commission of Oregon:

On behalf of the Confederated Tribes of the Umatilla Indian Reservation (CTUIR), I am writing to provide support for the 1.56 MW Tutuilla Solar Project and to reaffirm the CTUIR's position on renewable energy. The CTUIR has adopted a Strategic Energy Plan and a Climate Adaptation Plan, which strongly support renewable energy project development for the benefits it provides to both the community and our planet. For example, the Tutuilla Solar project will directly benefit the Umatilla Indian Reservation community through a subscription agreement whereby 10% of the power generated (i.e. financial benefits) will help off-set low-income tribal households' electricity bills. Additionally, annual fair market lease payments will be paid to the Tribal Government over the life of the project along with property taxes for providing essential governmental services.

The CTUIR is also interested in supporting additional community solar projects, net metering projects, rooftop solar projects, and upgrading the on-reservation electrical distribution grid system to support electrical vehicle charger deployment at numerous CTUIR facilities. Essential to many of these projects going forward is the interconnection and enhancement of the electrical distribution grid system. Without an efficient, timely, and cost-effective process in place for this, many of the proposed renewable energy projects are unable to proceed.

Our request for the Public Utility Commission is to encourage Pacific Power (PacifiCorp) to start the design and equipment procurement phase necessary for interconnecting the Tutuilla solar facility so the project can be completed in 2024. If you have any questions or need additional information, please contact Patrick Mills at [patrickmills@ctuir.org](mailto:patrickmills@ctuir.org) or Monica Paradise at [monicaparadise@ctuir.org](mailto:monicaparadise@ctuir.org).

Sincerely,



Donald G. Sampson, Executive Director

cc: [ezell.watson@puc.oregon.gov](mailto:ezell.watson@puc.oregon.gov)