



February 18, 2015

The Honorable Commissioners Ackerman, Bloom and Savage  
Oregon Public Utility Commission  
Attention: Joan Grindeland, Tariff Coordinator  
3930 Fairview Industrial Drive SE  
Salem, OR 97302-1166

RE: Advice No. OR15-01A for CenturyTel of Oregon

Dear Commissioners:

Attached for electronic filing are revised pages for CenturyTel of Oregon, Inc. Oregon P.U.C. AC4. This filing is submitted with a February 18, 2015 issue date and a proposed effective date of March 20, 2015.

The purpose of this filing is to Grandfather Frame Relay Access Service to existing customers and no longer offer this service to new customers on or after June 1, 2015.

Paper copies of the current Access Service Tariff sheets will be provided with the confirmation email and the filing.

Consideration and timely approval of these pages are respectfully requested. Questions concerning this filing may be directed to me at (303) 992-5832 or to Ron Trullinger at [Ron.Trullinger@CenturyLink.com](mailto:Ron.Trullinger@CenturyLink.com).

Yours very truly,

A handwritten signature in blue ink that reads "Mark Brinton".

Mark Brinton  
Manager Regulatory Operations  
Office: (303) 992-5832  
e-mail: [Mark.Brinton@CenturyLink.com](mailto:Mark.Brinton@CenturyLink.com)

Enclosures

**ACCESS SERVICE TARIFF**  
**OREGON P.U.C. AC4**

<b><u>SECTION</u></b>	<b><u>SHEET</u></b>	<b><u>REVISION</u></b>
Table of Contents	14.2	3rd
5	85	2nd
17	394	2nd
17	395	1st
17	396	1st
17	397	1st
17	398	1st
17	399	1st
17	400	1st
17	401	1st
17	402	1st
17	403	1st
17	404	1st
17	405	1st
17	406	1st

**ACCESS SERVICE TARIFF**

Oregon P.U.C. AC4  
CENTURYTEL OF OREGON, INC.

3rd Revised Page 14.2  
Cancels 2nd Revised Page 14.2

---

**TABLE OF CONTENTS (Cont'd)**

	<u>Page No.</u>	
16.8	383	<u>Virtual Collocation</u>
16.8.1	383	Availability of Service
16.8.2	384	Obligations of the Customer
16.8.3	384	Operation and Maintenance
16.8.4	385	Customer Terminating Equipment Requirements
16.9	387	<u>Rate Regulations</u>
16.9.1	387	Types of Rates and Charges
16.9.2	391	Minimum Periods
16.10	392	<u>Physical Collocation Rates and Charges</u>
16.10.1	392	Engineering Fee
16.10.2	392	Space and Power
16.11	393	<u>Virtual Collocation Rates and Charges</u>
16.12	393	<u>Cross Connect Charges</u>
16.13	393	<u>Wire Centers Exempt from Physical Collocation</u>
17.	394	<u>Public Packet Data Network</u>
17.1		<u>Frame Relay Service (Grandfathered)</u>
17.1.1	394	General
17.1.2	398	Rate Regulations
17.1.3	405	Rates and Charges
17.2	407	<u>Ethernet Service</u>
17.2.1	407	General
17.2.2	407	Service Description
17.2.3	408	Obligations of the Customer
17.2.4	408	Multiple Party Connections
17.2.5	409	Rate Categories
17.2.6	412	Application of Rates
17.2.7	415	Rate Regulations
17.2.8	422	Rates

---

Advice No. OR 15-01A  
Issued: February 18, 2015  
Issued by: CenturyTel of Oregon, Inc.  
By: Ron Trullinger, Director - Oregon

Effective: March 20, 2015

---

**5. ORDERING OPTIONS FOR SWITCHED AND SPECIAL ACCESS SERVICE****5.2 ACCESS ORDER (Cont'd)**

- When ordering Frame Relay Access Service[1], a minimum of two port connections are required for data to be transported between customer designated premises. When placing an order for Frame Relay Access Service the customer must specify the number of Permanent Virtual Connections (PVCs) required; the location of the ports for each PVC; the Committed Information Rates (CIRs) that will be associated with each PVC; and that the traffic does not consist of more than ten percent interstate traffic.

The port connecting the special access facility to the Telephone Company frame relay switch must be ordered and provided at the same speed as the special access facility. When connecting to the port of another customer, the ordering customer must obtain authorization from the other customer. When an extended PVC is ordered, the customer is responsible for placing the order with all telephone companies involved.

The BHMC is determined in the following manner. For each business day, the customer shall determine the highest number of minutes of use for a single hour (e.g., 55 minutes in the 10-11 AM hour). The customer shall, for the same hour period (i.e., busy hour) for each of twenty consecutive days, pick the twenty consecutive days in a calendar year which add up to the largest number of minutes of use. Both originating and terminating minutes shall be included. The customer shall then determine the average busy hour minutes of capacity (i.e., BHMC) by dividing largest number of minutes of use figure for the same hour period for the consecutive twenty day period by 20. This computation shall be performed for each end office the customer wishes to serve. These determinations thus establish the BHMC for each end office.

---

[1] Effective June 1, 2015, Frame Relay Access Service is restricted to existing customers and is no longer available to new customers. Existing customers may keep their service and continue to add circuits, as needed.

(N)  
|  
(N)

**17. PUBLIC PACKET DATA NETWORK**

Public Packet Data Networks utilize separate data networks, comprised of switching and transmission facilities. The networks provide for the transfer of data provided by a customer in a frame format. The data is separated into discrete segments for transmission through the public packet data network.

**17.1 FRAME RELAY ACCESS SERVICE (GRANDFATHERED)**

(C)

**17.1.1 GENERAL**

Effective June 1, 2015, Frame Relay Access Service is restricted to existing customers and is no longer available to new customers. Existing customers may keep their service and continue to add circuits, as needed.

(N)

|

(N)

**(A) General**

Frame Relay Access Service (FRAS) is a medium-speed, connection-oriented packet-switched data service that allows for the interconnection of Local Area Networks (LANs) or other compatible end user customer premises equipment for the purpose of connecting to an access customer's intrastate network. The terminal equipment accumulates the customers' data and puts it into a frame relay format suitable for transmission over the FRAS network. This terminal equipment must conform to American National Standards Institute and Committee Consultat de International Telegraphique et Telephonique (CCITT) standards.

FRAS permits customers to share network bandwidth for data transmissions. In addition to the regulations and charges specified in this section, the general regulations and charges specified in other sections of this tariff apply as appropriate.

**(B) Service Description**

FRAS is a transport service that facilitates the exchange of variable length information units (frames) between customer connections. Frames travel a fixed path through the network with an address that specifies the permanent virtual connection. Addresses are read by the network processor and the frames are relayed to the preassigned destination.

**17. PUBLIC PACKET DATA NETWORK**

**17.1 FRAME RELAY ACCESS SERVICE (GRANDFATHERED)**

(C)

**17.1.1 GENERAL**

(B) Service Description (Cont'd)

The service includes: the End User Port connection, the Access Customer Port connection, and Permanent Virtual Connections (PVC) which have associated Committed Information Rates (CIRs). A special access facility (ordered out of Section 7 preceding) is used to connect to the frame relay switch.

The End User Port connection permits FRAS compatible end user customer premises equipment (CPE) to originate or terminate an intrastate access service. Connections between end user customer premises equipment and the Telephone Company frame relay switch are available at speeds of 56.0 Kbps, 64.0 Kbps, or 1.544 Mbps. Each End User Port connection requires the identification of a corresponding terminating port connection(s).

The Access Customer Port connection connects the Telephone Company frame relay switch and the access customer's network. The facility connecting an access customer network to the Telephone Company frame relay switch is offered at 56.0 Kbps, 64.0 Kbps or 1.544 Mbps.

Connections are provided via Channel Terminations (see Section 7 Special Access Digital Data and High Capacity Service preceding). All regulations, rates and charges as specified in Section 7 will apply in addition to the rates and charges associated with FRAS.

All End User Port connections and Access Customer Port connections must be in conformance with accepted industry standards.

**17. PUBLIC PACKET DATA NETWORK**

**17.1 FRAME RELAY ACCESS SERVICE (GRANDFATHERED)**

(C)

**17.1.1 GENERAL**

(B) Service Description (Cont'd)

PVCs are software defined, end-to-end, bi-directional communications paths that are established and disestablished via the access service order process. While no physical circuits are dedicated, the two network addresses (one from each port connection) are connected electronically to form a PVC.

There are two types of PVCs available. The standard PVC establishes a communications path between two ports on the same frame relay switch. The extended PVC establishes a communications path between two ports on two interconnected telephone company frame relay switches.

At the time service is ordered the number of PVCs will be identified along with their Committed Information Rates. CIR is the bit rate at which the FRAS network commits to transfer data. Committed Information Rates provide for frame relay switch throughput at designated speeds. (See 17.1.2(A)(3) following.) This information is required for network routing purposes.

(C) Ordering Options and Conditions

Frame Relay Access Service is ordered under the Access Order provisions set forth in Section 5 preceding. Also included in that section are other charges which may be associated with ordering FRAS (e.g., Service Date Change Charges, Cancellation Charges, etc.)

A minimum of two FRAS port connections are required for data to be transported between customer designated premises.

**17. PUBLIC PACKET DATA NETWORK**

**17.1 FRAME RELAY ACCESS SERVICE (GRANDFATHERED)**

(C)

**17.1.1 GENERAL**

(C) Ordering Options and Conditions (Cont'd)

When placing an order for FRAS the customer must specify:

- the number of Permanent Virtual Connections (PVCs) required;
- the location of the ports for each PVC;
- the Committed Information Rates (CIRs) that will be associated with each PVC;
- that the traffic does not consist of more than ten percent interstate traffic.

The port connecting the special access facility to the Telephone Company frame relay switch must be ordered and provided at the same speed as the special access facility. When connecting to the port of another customer, the ordering customer must obtain authorization from the other customer. When an extended PVC is ordered, the customer is responsible for placing the order with all telephone companies involved.

(D) Acceptance Testing

At no additional charge, the Telephone Company will, at the customer's request, cooperatively test at the time of installation.



**17. PUBLIC PACKET DATA NETWORK**

**17.1 FRAME RELAY ACCESS SERVICE (GRANDFATHERED) (CONT'D)**

(C)

**17.1.2 RATE REGULATIONS**

This section contains the specific regulations governing the rates and charges that apply for Frame Relay Access Service.

(A) Rate Categories

The following diagrams depict a generic view of the components of FRAS and the manner in which the components are combined to provide Frame Relay Access Service and Interconnected Frame Relay Access Service.

**Frame Relay Access Service**

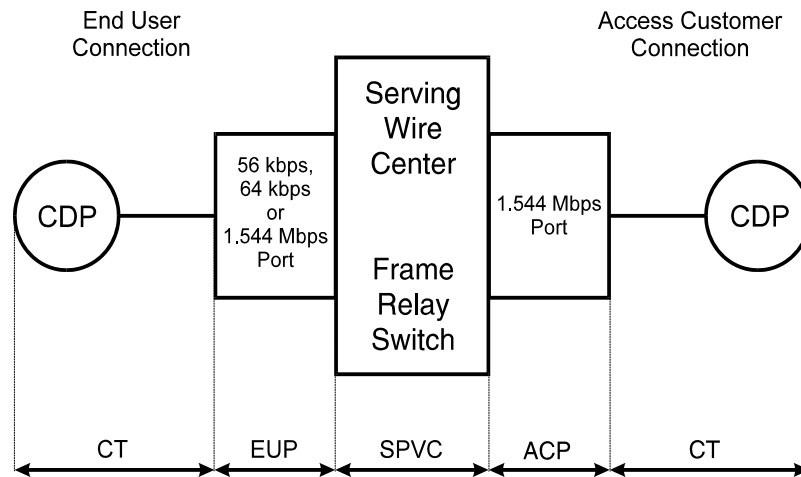

- |     |                                |      |   |
|-----|--------------------------------|------|---|
| CDP | - Customer Designated Premises | SPVC | - Standard Permanent Virtual Connection |
| CT  | - Channel Termination          | ACP  | - Access Customer Port                  |
| EUP | - End User Port                |      |   |

## ACCESS SERVICE TARIFF

Oregon P.U.C. AC4  
CENTURYTEL OF OREGON, INC.

1st Revised Page 399  
Cancels Original Page 399

### 17. PUBLIC PACKET DATA NETWORK

#### 17.1 FRAME RELAY ACCESS SERVICE (GRANDFATHERED)

##### 17.1.2 RATE REGULATIONS (CONT'D)

###### (A) Rate Categories (Cont'd)

(C)

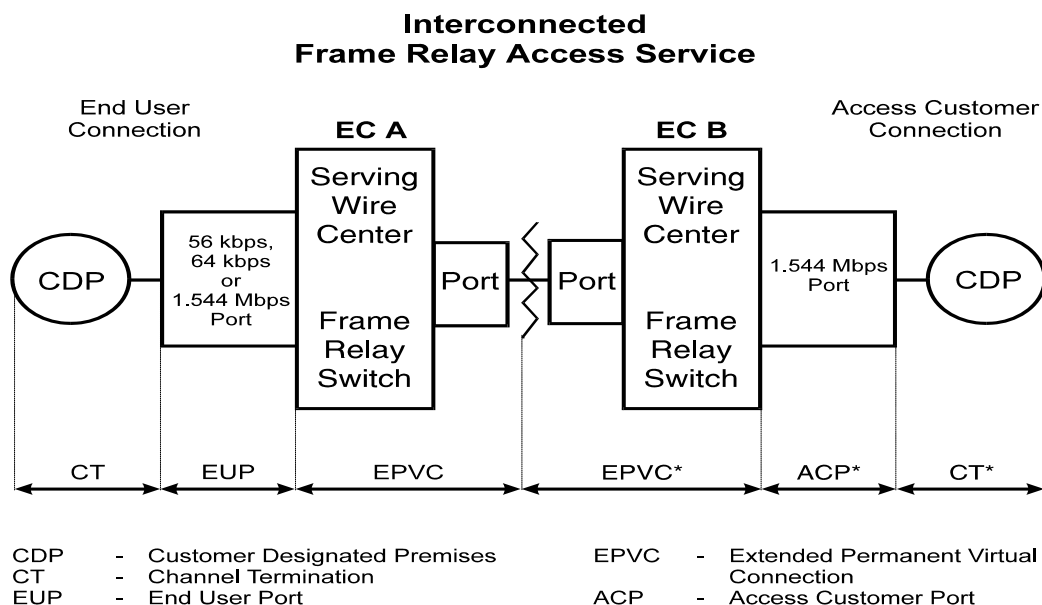

\* The application of these charges by EC B is dependent upon EC B's access tariff.

Frame Relay Access Service is available at the wire centers as identified in National Exchange Carrier Association, Inc. Tariff F.C.C. No. 4. In the case of Interconnected Frame Relay Access Service, National Exchange Carrier Association, Inc. Tariff F.C.C. No. 4 also identifies the intermediate and super intermediate wire centers.

#### (1) End User Port

The End User Port is the physical location in the Telephone Company switching office where the special access facility of the customer connects to the FRAS Network. It receives the data frame from the end user customer's Local Area Network or other compatible CPE device and verifies that the end user connection and the corresponding access customer connection are valid before relaying the frame to the destination end point.

Advice No. OR 15-01A  
Issued: February 18, 2015  
Issued by: CenturyTel of Oregon, Inc.  
By: Ron Trullinger, Director - Oregon

Effective: March 20, 2015

**17. PUBLIC PACKET DATA NETWORK**

**17.1 FRAME RELAY ACCESS SERVICE (GRANDFATHERED)**

(C)

**17.1.2 RATE REGULATIONS**

(A) Rate Categories

(1) End User Port (Cont'd)

The End User Port consists of either a 56.0 Kbps, 64.0 Kbps, or a 1.544 Mbps port interface connection. The port connecting the special access facility to the Telephone Company frame relay switch must be ordered and provided at the same speed as the special access facility.

(2) Access Customer Port

The Access Customer Port is the physical location in the Telephone Company switching offices where the access customer's special access facility connects to the Telephone Company's FRAS network. It specifies how a frame relay switch sends and receives data from a frame relay access customer's network. The Access Customer Port is offered at speeds of 56.0 Kbps, 64.0 Kbps or 1.544 Mbps. The port connecting the special access facility to the Telephone Company frame relay switch must be ordered and provided at the same speed as the special access facility.

**17. PUBLIC PACKET DATA NETWORK**

**17.1 FRAME RELAY ACCESS SERVICE (GRANDFATHERED)**

(C)

**17.1.2 RATE REGULATIONS**

(A) Rate Categories (Cont'd)

(3) Permanent Virtual Connection (PVC)

A PVC is a software defined communications path between two port connections within the FRAS network.

Each PVC is provisioned with a customer selected Committed Information Rate. The CIR is a transmission speed specified by the customer. CIRs range from 8 Kbps to 768 Kbps. The Telephone Company will provide switch capacity to permit the customer to transmit information with guaranteed delivery at the specified CIR. The Telephone Company will permit customers to attempt to transmit at speeds up to two times the CIR with no guarantee of completion. Attempted transmissions at above two times the CIR will not be permitted.

Customers will be permitted to order multiple PVCs on a given port subject to switch limitations. Customers anticipating non-simultaneous transmission may order CIRs assigned to these multiple PVCs, the sum of which may theoretically exceed the actual throughput of the port. However, when simultaneous transmission of multiple PVCs occurs, the total of the transmission rate (CIRs) may not exceed the actual throughput of the port.

There are two types of PVCs available. The standard PVC establishes a communications path between the End User Port and the Access Customer Port on the same frame relay switch. The extended PVC establishes a communications path between the End User Port on a Telephone Company's frame relay switch and an Access Customer Port on another interconnected Telephone Company's frame relay switch.

There is no monthly charge for the first Standard PVC ordered per each End User Port or Access Customer Port. PVC Installation charges as set forth in 17.1.3(A)(4) following will apply to each PVC.

**17. PUBLIC PACKET DATA NETWORK**

**17.1 FRAME RELAY ACCESS SERVICE (GRANDFATHERED)**

(C)

**17.1.2 RATE REGULATIONS** (Cont'd)

(B) Types of Rates and Charges

There are two types of rates and charges. They are monthly rates and nonrecurring charges. The rates and charges are described as follows:

(1) Monthly Rates

Monthly rates are recurring rates that apply each month or fraction thereof that a FRAS is provided. For billing purposes, each month is considered to have 30 days.

(2) Nonrecurring Charges

Nonrecurring charges are one-time charges that apply for specific work activity (i.e., installation or change to an existing service). The types of nonrecurring charges that apply for FRAS are: installation of service and service rearrangements.

(a) Installation of Service

Nonrecurring charges apply for the installation of all PVCs.

**17. PUBLIC PACKET DATA NETWORK**

**17.1 FRAME RELAY ACCESS SERVICE (GRANDFATHERED)**

(C)

**17.1.2 RATE REGULATIONS**

(B) Types of Rates and Charges

(2) Nonrecurring Charges (Cont'd)

(b) Service Rearrangements

Service Rearrangements are changes to existing (installed) services.

A PVC Rearrangement Charge will be applied whenever a change is made to the CIR of an existing PVC after initial port installation and/or a change is made to the terminating port destination of the PVC.

Administrative changes will be made without charge(s) to the customer. Administrative changes are as follows:

- Change of customer name,
- Change of customer or customer's end user premises address when the change of address is not a result of physical relocation of equipment,
- Change in billing data (name, address, or contact name or telephone number),
- Change of agency authorization,
- Change of customer circuit identification,
- Change of billing account number,
- Change of customer or customer's end user contact name or telephone number, and
- Change of jurisdiction.

**ACCESS SERVICE TARIFF**

Oregon P.U.C. AC4  
CENTURYTEL OF OREGON, INC.

1st Revised Page 404  
Cancels Original Page 404

---

**17. PUBLIC PACKET DATA NETWORK**

**17.1 FRAME RELAY ACCESS SERVICE (GRANDFATHERED)**

(C)

**17.1.2 RATE REGULATIONS** (Cont'd)

(C) Minimum Period

The minimum period for FRAS is one month and the full monthly rate will apply to the first month. Adjustments for quantities of services established or discontinued in any billing period beyond the minimum period for the Frame Relay Access Service 1.544 Mbps port are as set forth in 2.4.2 and 5.5.1.

---

Advice No. OR 15-01A  
Issued: February 18, 2015  
Issued by: CenturyTel of Oregon, Inc.  
By: Ron Trullinger, Director - Oregon

Effective: March 20, 2015

ACCESS SERVICE TARIFF

Oregon P.U.C. AC4  
CENTURYTEL OF OREGON, INC.

1st Revised Page 405  
Cancels Original Page 405

17. PUBLIC PACKET DATA NETWORK

**17.1 FRAME RELAY ACCESS SERVICE (GRANDFATHERED) (CONT'D)**

(C)

**17.1.3 RATES AND CHARGES**

	USOC	MONTHLY RATE
(A) Connections		
(1) End User Port Per Port		
- 56.0 Kbps	FRP56	\$ 45.00
- 64.0 Kbps	FRP64	45.00
- 1.544 Mbps	FRPDS1	225.00
(2) Access Customer Port Per Port		
- 56.0 Kbps	FRP56	\$ 45.00
- 64.0 Kbps	FRP64	45.00
- 1.544 Mbps	FRPDS1	225.00
(3) Permanent Virtual Connections (PVCs)		
• Standard (Additional after first PVC Per Port)		
<u>CIR</u>		
- 8 Kbps	PVC8	\$ 5.00
- 16 Kbps	PVC16	5.00
- 28 Kbps	PVC28	6.00
- 32 Kbps	PVC32	6.00
- 56 Kbps	PVC56	7.00
- 64 Kbps	PVC64	9.00
- 128 Kbps	PVC128	12.00
- 192 Kbps	PVC192	14.00
- 256 Kbps	PVC256	20.00
- 384 Kbps	PVC384	28.00
- 512 Kbps	PVC512	36.00
- 768 Kbps	PVC768	48.00

(T)

Advice No. OR 15-01A  
Issued: February 18, 2015  
Issued by: CenturyTel of Oregon, Inc.  
By: Ron Trullinger, Director - Oregon

Effective: March 20, 2015



**ACCESS SERVICE TARIFF**

Oregon P.U.C. AC4  
CENTURYTEL OF OREGON, INC.

1st Revised Page 406  
Cancels Original Page 406

**17. PUBLIC PACKET DATA NETWORK**

**17.1 FRAME RELAY ACCESS SERVICE (GRANDFATHERED)**

(C)

**17.1.3 RATES AND CHARGES**

(3) Permanent Virtual Connections (PVCs) (Cont'd)

	<b>MONTHLY RATE</b>	
• Extended, Per PVC Per Port		(T)
<u>CIR</u>		
- 8 Kbps	ICB	
- 16 Kbps	ICB	
- 28 Kbps	ICB	
- 32 Kbps	ICB	
- 56 Kbps	ICB	
- 64 Kbps	ICB	
- 128 Kbps	ICB	
- 192 Kbps	ICB	
- 256 Kbps	ICB	
- 384 Kbps	ICB	
- 512 Kbps	ICB	
- 768 Kbps	ICB	

	<b>USOC</b>	<b>NONRECURRING CHARGE</b>
(4) PVC Installation Charge Per PVC Per Port		
- 56 Kbps	NPVC56	\$ 50.00
- 64 Kbps	NPVC64	50.00
- 1.544 Mbps	NPVDS1	50.00
(5) PVC Rearrangement Charge		
	NPVRC	25.00